

PROGRAMMABLE CONTROLLERS



MELSEC iQ-F
series



MELSEC iQ-F
FX5UC User's Manual (Hardware)

SAFETY PRECAUTIONS

(Read these precautions before use.)

Before using this product, please read this manual and the relevant manuals introduced in this manual carefully and pay full attention to safety in order to handle the product correctly.

This manual classifies the safety precautions into two categories: [ WARNING] and [ CAUTION].

 WARNING	Indicates that incorrect handling may cause hazardous conditions, resulting in death or severe injury.
 CAUTION	Indicates that incorrect handling may cause hazardous conditions, resulting in minor or moderate injury or property damage.

Depending on the circumstances, procedures indicated by [ CAUTION] may also cause severe injury.

It is important to follow all precautions for personal safety.

Store this manual in a safe place so that it can be read whenever necessary. Always forward it to the end user.

[DESIGN PRECAUTIONS]

WARNING

- Make sure to set up the following safety circuits outside the PLC to ensure safe system operation even during external power supply problems or PLC failure. Otherwise, malfunctions may cause serious accidents.
 - Most importantly, set up the following: an emergency stop circuit, a protection circuit, an interlock circuit for opposite movements (such as forward vs. reverse rotation), and an interlock circuit to prevent damage to the equipment at the upper and lower positioning limits.
 - Note that when the CPU module detects an error, such as a watchdog timer error, during self-diagnosis, all outputs are turned off. Also, when an error that cannot be detected by the CPU module occurs in an input/output control block, output control may be disabled. External circuits and mechanisms should be designed to ensure safe machine operation in such a case.
 - Note that when an error occurs in a relay, transistor or triac of an output circuit, the output might stay on or off. For output signals that may lead to serious accidents, external circuits and mechanisms should be designed to ensure safe machine operation.
 - Construct an interlock circuit in the program so that the whole system always operates on the safe side before executing the control (for data change) of the PLC in operation.
Read the manual thoroughly and ensure complete safety before executing other controls (for program change, parameter change, forced output and operation status change) of the PLC in operation. Otherwise, the machine may be damaged and accidents may occur due to erroneous operations.
 - In an output circuit, when a load current exceeding the current rating or an overcurrent caused by a load short-circuit flows for a long time, it may cause smoke and fire. To prevent this, configure an external safety circuit, such as a fuse.
 - For the operating status of each station after a communication failure of the network, refer to relevant manuals for the network. Incorrect output or malfunction may result in an accident.
-

[DESIGN PRECAUTIONS]

CAUTION

- When an inductive load such as a lamp, heater, or solenoid valve is controlled, a large current (approximately ten times greater than normal) may flow when the output is turned from off to on. Take proper measures so that the flowing current does not exceed the value corresponding to the maximum load specification of the resistance load.
 - After the CPU module is powered on or is reset, the time taken to enter the RUN status varies depending on the system configuration, parameter settings, and/or program size.
Design circuits so that the entire system will always operate safely, regardless of this variation in time.
 - Simultaneously turn on and off the power supplies of the CPU module and extension modules.
 - If a long-time power failure or an abnormal voltage drop occurs, the PLC stops, and output is turned off. When the power supply is restored, it will automatically restart (when the RUN/STOP/RESET switch is on RUN side).
-

[INSTALLATION PRECAUTIONS]

WARNING

- Make sure to cut off all phases of the power supply externally before attempting installation or wiring work. Failure to do so may cause electric shock or damage to the product.
 - Use the product within the generic environment specifications described in  Page 17 Generic Specifications of this manual.
Never use the product in areas with excessive dust, oily smoke, conductive dusts, corrosive gas (salt air, Cl₂, H₂S, SO₂ or NO₂), flammable gas, vibration or impacts, or expose it to high temperature, condensation, or rain and wind.
If the product is used in such conditions, electric shock, fire, malfunctions, deterioration or damage may occur.
-

[INSTALLATION PRECAUTIONS]

CAUTION

- Do not touch the conductive parts of the product directly. Doing so may cause device failures or malfunctions.
 - When drilling screw holes or wiring, make sure that cutting and wiring debris do not enter the ventilation slits of the PLC. Failure to do so may cause fire, equipment failures or malfunctions.
 - For product supplied together with a dust proof sheet, the sheet should be affixed to the ventilation slits before the installation and wiring work in order to block foreign objects such as cutting and wiring debris.
However, when the installation work is completed, make sure to remove the sheet to provide adequate ventilation. Failure to do so may cause fire, equipment failures or malfunctions.
 - Install the product on a flat surface. If the mounting surface is rough, undue force will be applied to the PC board, thereby causing nonconformities.
 - Install the product securely using a DIN rail.
 - Connect the expansion adapter securely to their designated connectors. Loose connections may cause malfunctions.
 - Work carefully when using a screwdriver during product installation. Failure to do so may cause damage to the product or accidents.
 - Connect the extension cables, peripheral device cables, input/output cables and battery connecting cable securely to their designated connectors. Loose connections may cause malfunctions.
 - When using an SD memory card, insert it into the SD memory card slot. Check that it is inserted completely. Poor contact may cause malfunction.
 - Turn off the power to the PLC before attaching or detaching the following devices. Failure to do so may cause device failures or malfunctions.
 - Peripheral devices and expansion adapter
 - Extension modules, bus conversion module and connector conversion module
 - Battery
-

[WIRING PRECAUTIONS]

WARNING

- Make sure to cut off all phases of the power supply externally before attempting installation or wiring work. Failure to do so may cause electric shock or damage to the product.
 - Make sure to attach the terminal cover, provided as an accessory, before turning on the power or initiating operation after installation or wiring work. Failure to do so may cause electric shock.
 - The temperature rating of the cable should be 80°C or more.
 - Make sure to wire the screw terminal block in accordance with the following precautions. Failure to do so may cause electric shock, equipment failures, a short-circuit, wire breakage, malfunctions, or damage to the product.
 - Wire terminals should follow the dimensions described in the manual.
 - Tightening torque should follow the specifications in the manual.
 - Tighten the screws using a Phillips-head screwdriver No. 2 (shaft diameter 6 mm (0.24") or less). Make sure that the screwdriver does not touch the partition part of the terminal block.
 - Make sure to wire the terminal block (European type) in accordance with the following precautions. Failure to do so may cause electric shock, equipment failures, a short-circuit, wire breakage, malfunctions, or damage to the product.
 - Wire terminals should follow the dimensions described in the manual.
 - Tightening torque should follow the specifications in the manual.
 - Twist the ends of stranded wires and make sure that there are no loose wires.
 - Do not solder-plate the electric wire ends.
 - Do not connect more than the specified number of wires or electric wires of unspecified size.
 - Affix the electric wires so that neither the terminal block nor the connected parts are directly stressed.
-

[WIRING PRECAUTIONS]

CAUTION

- Perform class D grounding (grounding resistance: 100 Ω or less) of the grounding terminal on the CPU module and extension modules with a wire 2 mm² or thicker.
However, do not use common grounding (refer to  Page 56 Grounding) with heavy electrical systems.
 - Connect the power supply wiring to the dedicated terminals described in this manual. If an AC power supply is connected to a DC input/output terminal or DC power supply terminal, the PLC will burn out.
 - Do not wire vacant terminals externally. Doing so may cause damage to the product.
 - Install module so that excessive force will not be applied to terminal blocks, power connectors, I/O connectors, communication connectors, or communication cables. Failure to do so may result in wire damage/breakage or PLC failure.
-

CAUTION

- Make sure to observe the following precautions in order to prevent any damage to the machinery or accidents due to malfunction of the PLC caused by abnormal data written to the PLC due to the effects of noise.
 - Do not bundle the power line, control line and communication cables together with or lay them close to the main circuit, high-voltage line, load line or power line. As a guideline, lay the power line, control line and connection cables at least 100 mm (3.94") away from the main circuit, high-voltage line, load line or power line.
 - Ground the shield of the shield wire or shielded cable at one point on the PLC. However, do not use common grounding with heavy electrical systems.
 - Ground the shield of the analog input/output cable at one point on the signal receiving side. Do not use common grounding with heavy electrical systems.

[STARTUP AND MAINTENANCE PRECAUTIONS]

WARNING

- Do not touch any terminal while the PLC's power is on. Doing so may cause electric shock or malfunctions.
 - Before cleaning or retightening terminals, cut off all phases of the power supply externally. Failure to do so may cause electric shock.
 - Before modifying the program in mid-operation, forcing output, running or stopping the PLC, read through this manual carefully, and ensure complete safety. An operation error may damage the machinery or cause accidents.
 - Do not change the program in the PLC from two or more peripheral equipment devices at the same time. (i.e. from an engineering tool and a GOT) Doing so may cause destruction or malfunction of the PLC program.
 - Use the battery for memory backup in conformance to this manual.
 - Use the battery for the specified purpose only.
 - Connect the battery correctly.
 - Do not charge, disassemble, heat, put in fire, short-circuit, connect reversely, weld, swallow or burn the battery, or apply excessive force (vibration, impact, drop, etc.) to the battery.
 - Do not store or use the battery at high temperatures or expose to direct sunlight.
 - Do not expose to water, bring near fire or touch liquid leakage or other contents directly.
- Incorrect handling of the battery may cause excessive heat, bursting, ignition, liquid leakage or deformation, and lead to injury, fire or failures and malfunction of facilities and other equipment.
-

[STARTUP AND MAINTENANCE PRECAUTIONS]

CAUTION

- Do not disassemble or modify the PLC. Doing so may cause fire, equipment failures, or malfunctions.
*For repair, contact your local Mitsubishi Electric representative.
 - After the first use of the SD memory card, do not insert/remove the memory card more than 500 times. Insertion/removal 500 times or more may cause malfunction.
 - Turn off the power to the PLC before connecting or disconnecting any extension cable. Failure to do so may cause device failures or malfunctions.
 - Turn off the power to the PLC before attaching or detaching the following devices. Failure to do so may cause device failures or malfunctions.
 - Peripheral devices and expansion adapter
 - Extension modules, bus conversion module and connector conversion module
 - Battery
-

[OPERATION PRECAUTIONS]

CAUTION

- Construct an interlock circuit in the program to ensure safe operation for the whole system when executing control (for data change) of the PLC in operation. Read the manual thoroughly and ensure complete safety before executing other controls (for program change, parameter change, forced output and operation status change) of the PLC in operation. Otherwise, the machine may be damaged and accidents may occur by erroneous operations.
-



[DISPOSAL PRECAUTIONS]

CAUTION

- Please contact a certified electronic waste disposal company for the environmentally safe recycling and disposal of your device.
 - When disposing of batteries, separate them from other waste according to local regulations. For details on the Battery Directive in EU countries, refer to  Page 140 Handling of Batteries and Devices with Built-in Batteries in EU Member States.
-

[TRANSPORTATION PRECAUTIONS]

CAUTION

- When transporting the PLC with the optional battery, turn on the PLC before shipment, confirm that the battery mode is set in PLC parameters and the BAT LED is OFF, and check the battery life. If the PLC is transported with the BAT LED on or the battery exhausted, the battery-backed data may be lost during transportation.
 - The PLC is a precision instrument. During transportation, avoid impacts larger than those specified in the general specifications ( Page 17 Generic Specifications) by using dedicated packaging boxes and shock-absorbing pallettes. Failure to do so may cause failures in the PLC. After transportation, verify operation of the PLC and check for damage of the mounting part, etc.
 - When transporting lithium batteries, follow required transportation regulations. For details on the regulated products, refer to  Page 140 Handling of Batteries and Devices with Built-in Batteries in EU Member States.
 - Fumigants that contain halogen materials such as fluorine, chlorine, bromine, and iodine used for disinfecting and protecting wooden packaging from insects will cause malfunction in Mitsubishi products. Please take necessary precautions to ensure that residual fumigants do not enter the product, or treat packaging with methods other than fumigation (heat method). Additionally, disinfect and protect wood from insects before packing.
-

INTRODUCTION

This manual contains text, diagrams and explanations which will guide the reader in the correct installation, safe use and operation of the FX5UC Programmable Controllers and should be read and understood before attempting to install or use the module.

Always forward it to the end user.

Regarding use of this product

- This product has been manufactured as a general-purpose part for general industries, and has not been designed or manufactured to be incorporated in a device or system used in purposes related to human life.
- Before using the product for special purposes such as nuclear power, electric power, aerospace, medicine or passenger movement vehicles, consult Mitsubishi Electric.
- This product has been manufactured under strict quality control. However when installing the product where major accidents or losses could occur if the product fails, install appropriate backup or failsafe functions in the system.

Note

- If in doubt at any stage during the installation of the product, always consult a professional electrical engineer who is qualified and trained in the local and national standards. If in doubt about the operation or use, please consult the nearest Mitsubishi Electric representative.
- Since the examples indicated by this manual, technical bulletin, catalog, etc. are used as a reference, please use it after confirming the function and safety of the equipment and system. Mitsubishi Electric will accept no responsibility for actual use of the product based on these illustrative examples.
- This manual content, specification etc. may be changed, without a notice, for improvement.
- The information in this manual has been carefully checked and is believed to be accurate; however, if you notice a doubtful point, an error, etc., please contact the nearest Mitsubishi Electric representative. When doing so, please provide the manual number given at the end of this manual.

CONTENTS

SAFETY PRECAUTIONS	1
INTRODUCTION	7
RELEVANT MANUALS	12
TERMS	12
CHAPTER 1 OUTLINE	14
1.1 Part Names	14
Front panel	14
Side	15
CHAPTER 2 SPECIFICATIONS	17
2.1 Generic Specifications	17
2.2 Power Supply Specifications	18
DC power supply	18
2.3 Input Specifications	18
24 V DC input (sink/source)	18
2.4 Output Specifications	20
Transistor output	20
2.5 Input/Output Derating Curve	20
2.6 Performance Specifications	21
2.7 Communication Specifications	23
Built-in Ethernet communication	23
Built-in RS-485 communication	23
2.8 External Dimensions	24
FX5UC-32MT/D, FX5UC-32MT/DSS	24
2.9 Terminal Layout	25
CHAPTER 3 PRODUCT LIST	26
3.1 Overall Configuration	26
3.2 CPU Module	27
3.3 Extension Module	28
I/O module	28
Intelligent function module	30
Bus conversion module	31
Connector conversion module	31
3.4 Expansion Adapter	31
3.5 Terminal Module	32
3.6 SD Memory Card	32
3.7 Battery	32
3.8 Communication Cable	32
3.9 Engineering Tool	32
CHAPTER 4 SYSTEM CONFIGURATION	33
4.1 Rules of System Configuration	34
4.2 Limitations on the Number of Connected Extension Devices	36
Number of connected expansion adapters	36
Number of connected extension modules	36
4.3 Limitation on the Number of Input/Output Points	38

	Total number of I/O points and remote I/O points	38
	Calculation of the number of input/output points	39
	Calculation of the number of remote I/O points	39
4.4	Limitation on Current Consumption	41
	Power supply check from the CPU module (current consumption calculation)	41
4.5	Numbers and Assignment in System	42
	Module input/output number	42
	Module number of Extension modules	42
CHAPTER 5 INSTALLATION		43
5.1	Installation Location	43
	Installation location in enclosure	43
	Spaces in enclosure	43
	Layout in enclosure	43
5.2	Examination for Installing Method in Enclosure	44
5.3	Procedures for Installing on and Detaching from DIN Rail	44
	Preparation for installation	44
	Installation of CPU module	45
	Installation of extension modules (extension cable type)	45
	Installation of terminal modules	46
	Removal of CPU module	46
5.4	Connecting Methods for CPU Module and Extension Devices	46
	Connection of extension devices	46
	Connecting method A - connection of an expansion adapter	47
	Connecting method B - connection of an extension module (extension connector type)	47
	Connecting method C - connection of a connector conversion module (extension connector type) and an extension module (extension cable type)	48
	Connecting method D - connection between extension modules (extension cable type)	48
	Connecting method E - connection of a bus conversion module and an FX3 intelligent function module	49
	Connection of power cables	50
	Removal of power cables	51
	Connection of I/O cables	51
CHAPTER 6 WIRING		53
6.1	Wiring Preparations	53
	Wiring procedure	53
6.2	Cable Connecting Procedure	54
	European-type terminal block	54
	Screw terminal block	55
6.3	Grounding	56
6.4	Power Supply Wiring	57
	Examples of DC power supply wiring	57
6.5	Input Wiring	59
	24 V DC input	59
	Input wiring example	63
	Input wiring examples of terminal modules	66
6.6	Output Wiring	68
	Transistor output	68
	Relay output	71
	Triac output	74

	Output wiring example	76
	Output wiring examples of terminal modules	79
6.7	Examples of Wiring for Various Uses	83
	Built-in positioning function	83
	Communication function	83
	High-speed counter	83
	Interruption	86
	Digital Switch	87
	Input Matrix	89
	Seven Segment with Latch	90

CHAPTER 7 OPERATION ADJUSTMENT 92

7.1	Preparation for Operation	92
	Preliminary inspection	92
	Procedure until operation	92
	Connection with a personal computer	93
7.2	Operation and Test	94
	Self-diagnostic function	94
	Monitoring and debugging	94
7.3	Running, Stopping, and Resetting	95
	Methods of running, stopping, and resetting	95

CHAPTER 8 MAINTENANCE AND INSPECTION 96

8.1	Daily Inspection	96
8.2	Periodic Inspection	96
8.3	Battery	97
	Part names	97
	Specifications	97
	Battery attachment	97
	Battery replacement	98
	Special relay for low battery voltage	100

CHAPTER 9 TROUBLESHOOTING 101

9.1	Troubleshooting Procedure	101
9.2	Checking with LEDs	101
	Checking the PWR LED	101
	Checking the BAT LED	101
	Checking the ERR LED	102
	Checking the P.RUN LED	102
9.3	Troubleshooting using the engineering tool	102
	Module Diagnostics (CPU Diagnostics)	103
9.4	Error Status and Operations on Occurrence of an Error	104
9.5	Backing Up the Data	105
9.6	Canceling Errors	105
9.7	Troubleshooting for Each Symptom	106
	I/O operation (CPU module, I/O module)	106
	PLC write, PLC read	107
	Boot operation	107

APPENDIX	108
Appendix 1 How to Check the Date of Manufacture	108
Appendix 2 Standards	109
Certification of UL, cUL standards	109
Compliance with EC directive (CE Marking)	109
Requirement for compliance with EMC directive	109
Requirement for Compliance with LVD directive	110
Caution for compliance with EC Directive	110
Appendix 3 I/O Module	112
Product configuration	112
Product list	112
Specifications	113
External dimensions and component names	119
Terminal layout	121
Appendix 4 SD Memory Card	123
Part names	123
Specifications	123
Insertion and removal of the SD memory card	124
Appendix 5 Terminal Module	125
Product configuration	125
Product list	125
Specifications	126
External dimensions and component names	131
Terminal layout	132
Internal circuit	133
Appendix 6 Precautions for Battery Transportation	139
Control-subject product	139
Precautions for transportation	139
Appendix 7 Handling of Batteries and Devices with Built-in Batteries in EU Member States	140
Disposal precautions	140
Exportation precautions	140
INDEX	141
REVISIONS	142
WARRANTY	143
TRADEMARKS	144

RELEVANT MANUALS

User's manuals for the applicable modules

Manual name <manual number>	Description
MELSEC iQ-F FX5UC CPU Module Hardware Manual <JY997D61001>	Describes the details of input/output specifications, wiring and installation of the FX5UC CPU module from MELSEC iQ-F FX5UC User's Manual (Hardware).
MELSEC iQ-F FX5 User's Manual (Startup) <JY997D58201>	Performance specifications, procedures before operation, and troubleshooting of the CPU module.
MELSEC iQ-F FX5U User's Manual (Hardware) <JY997D55301>	Describes the details of hardware of the FX5U CPU module, including input/output specifications, wiring, installation, and maintenance.
MELSEC iQ-F FX5UC User's Manual (Hardware) <JY997D61401> (This manual)	Describes the details of hardware of the FX5UC CPU module, including input/output specifications, wiring, installation, and maintenance.
MELSEC iQ-F FX5 User's Manual (Application) <JY997D55401>	Describes basic knowledge required for program design, functions of the CPU module, devices/labels, and parameters.
MELSEC iQ-F FX5 Programming Manual (Program Design) <JY997D55701>	Describes specifications of ladders, ST, FBD/LD, and other programs and labels.
MELSEC iQ-F FX5 Programming Manual (Instructions, Standard Functions/Function Blocks) <JY997D55801>	Describes specifications of instructions and functions that can be used in programs.
MELSEC iQ-F FX5 User's Manual (Serial Communication) <JY997D55901>	Describes N:N network, MELSEC Communication protocol, inverter communication, non-protocol communication, and predefined protocol support.
MELSEC iQ-F FX5 User's Manual (MODBUS Communication) <JY997D56101>	Describes MODBUS serial communication.
MELSEC iQ-F FX5 User's Manual (Ethernet Communication) <JY997D56201>	Describes the functions of the built-in Ethernet port communication function.
MELSEC iQ-F FX5 User's Manual (SLMP) <JY997D56001>	Explains methods for the device that is communicating with the CPU module by SLMP to read and write the data of the CPU module.
MELSEC iQ-F FX5 User's Manual (Positioning Control) <JY997D56301>	Describes the built-in positioning function.
MELSEC iQ-F FX5 User's Manual (Analog Control) <JY997D60501>	Describes the analog function.
GX Works3 Operating Manual <SH-081215ENG>	System configuration, parameter settings, and online operations of GX Works3.

TERMS

Unless otherwise specified, this manual uses the following terms.

- indicates a variable part to collectively call multiple models or versions.

(Example) FX5-C32EX/D, FX5-C32ET/D, FX5-C32EYT/D ⇒ FX5-C32E□/D

- For details on the FX3 devices that can be connected with the FX5UC CPU module, refer to  Page 26 PRODUCT LIST.

Terms	Description
■Devices	
FX5	Generic term for FX5U and FX5UC PLCs
FX3	Generic term for FX3S, FX3G, FX3GC, FX3U, and FX3UC PLCs
FX5 CPU module	Generic term for FX5U CPU module and FX5UC CPU module
FX5U CPU module	Generic term for FX5U-32MR/ES, FX5U-32MT/ES, FX5U-32MT/ESS, FX5U-64MR/ES, FX5U-64MT/ES, FX5U-64MT/ESS, FX5U-80MR/ES, FX5U-80MT/ES, and FX5U-80MT/ESS
FX5UC CPU module	Generic term for FX5UC-32MT/D and FX5UC-32MT/DSS
Extension module	Generic term for FX5 extension modules and FX3 extension modules
• FX5 extension module	Generic term for I/O modules, and FX5 intelligent function modules
• FX3 extension module	Generic term for FX3 intelligent function module
Extension module (extension cable type)	Input modules (extension cable type), Output modules (extension cable type), Bus conversion module (extension cable type), and Intelligent function modules
Extension module (extension connector type)	Input modules (extension connector type), Output modules (extension connector type), Input/output modules, Bus conversion module (extension connector type), and Connector conversion module (extension connector type)
I/O module	Generic term for input modules, output modules, and Input/output modules

Terms	Description
Input module	Generic term for Input modules (extension cable type) and Input modules (extension connector type)
• Input module (extension cable type)	Generic term for FX5-8EX/ES and FX5-16EX/ES
• Input module (extension connector type)	Generic term for FX5-C32EX/D and FX5-C32EX/DS
Output module	Generic term for output modules (extension cable type) and output modules (extension connector type)
• Output module (extension cable type)	Generic term for FX5-8EYR/ES, FX5-8EYT/ES, FX5-8EYT/ESS, FX5-16EYR/ES, FX5-16EYT/ES, and FX5-16EYT/ESS
• Output module (extension connector type)	Generic term for FX5-C32EYT/D and FX5-C32EYT/DSS
Input/output modules	Generic term for FX5-C32ET/D and FX5-C32ET/DSS
Intelligent module	The abbreviation for intelligent function modules
Intelligent function module	Generic term for FX5 intelligent function modules and FX3 intelligent function modules
• FX5 intelligent function module	Generic term for FX5 intelligent function modules
• FX3 intelligent function module	Different name for FX3 special function blocks
Simple motion module	Different name for FX5-40SSC-S
Expansion adapter	Generic term for adapter for FX5 CPU module
• Communication adapter	Generic term for FX5-232ADP and FX5-485ADP
• Analog adapter	Generic term for FX5-4AD-ADP and FX5-4DA-ADP
Bus conversion module	Generic term for Bus conversion module (extension cable type) and Bus conversion module (extension connector type)
• Bus conversion module (extension cable type)	Different name for FX5-CNV-BUS
• Bus conversion module (extension connector type)	Different name for FX5-CNV-BUSC
Battery	Different name for FX3U-32BL
SD memory card	Generic term for NZ1MEM-2GBSD, NZ1MEM-4GBSD, L1MEM-2GBSD and L1MEM-4GBSD SD memory cards Abbreviation of Secure Digital Memory Card. Device that stores data using flash memory.
Peripheral device	Generic term for engineering tools and GOTs
GOT	Generic term for Mitsubishi Graphic Operation Terminal GOT1000 and GOT2000 series
■Software packages	
Engineering tool	The product name of the software package for the MELSEC programmable controllers
GX Works3	The product name of the software package, SWnDND-GXW3, for the MELSEC programmable controllers (The 'n' represents a version.)
■Manuals	
Hardware manual	Generic term for manuals enclosed with the product
• FX5UC Hardware manual	Abbreviation of MELSEC iQ-F FX5UC CPU Module Hardware Manual
User's manual	Generic term for separate manuals
• User's manual (Startup)	Abbreviation of MELSEC iQ-F FX5 User's Manual (Startup)
• User's manual (Hardware)	Abbreviation of MELSEC iQ-F FX5UC User's Manual (Hardware)
• User's manual (Application)	Abbreviation of MELSEC iQ-F FX5 User's Manual (Application)
Programming manual (Program Design)	Abbreviation of MELSEC iQ-F FX5 Programming Manual (Program Design)
Programming manual (Instructions, Standard Functions/Function Blocks)	Abbreviation of MELSEC iQ-F FX5 Programming Manual (Instructions, Standard Functions/Function Blocks)
Communication manual	Generic term for MELSEC iQ-F FX5 User's Manual (Serial Communication), MELSEC iQ-F FX5 User's Manual (MODBUS Communication), MELSEC iQ-F FX5 User's Manual (Ethernet Communication), and MELSEC iQ-F FX5 User's Manual (SLMP)
• Serial communication manual	Abbreviation of MELSEC iQ-F FX5 User's Manual (Serial Communication)
• MODBUS communication manual	Abbreviation of MELSEC iQ-F FX5 User's Manual (MODBUS Communication)
• Ethernet communication manual	Abbreviation of MELSEC iQ-F FX5 User's Manual (Ethernet Communication)
• SLMP manual	Abbreviation of MELSEC iQ-F FX5 User's Manual (SLMP)
Positioning manual	Abbreviation of MELSEC iQ-F FX5 User's Manual (Positioning Control)
Analog manual	Abbreviation of MELSEC iQ-F FX5 User's Manual (Analog Control)

1 OUTLINE

1.1 Part Names

Front panel

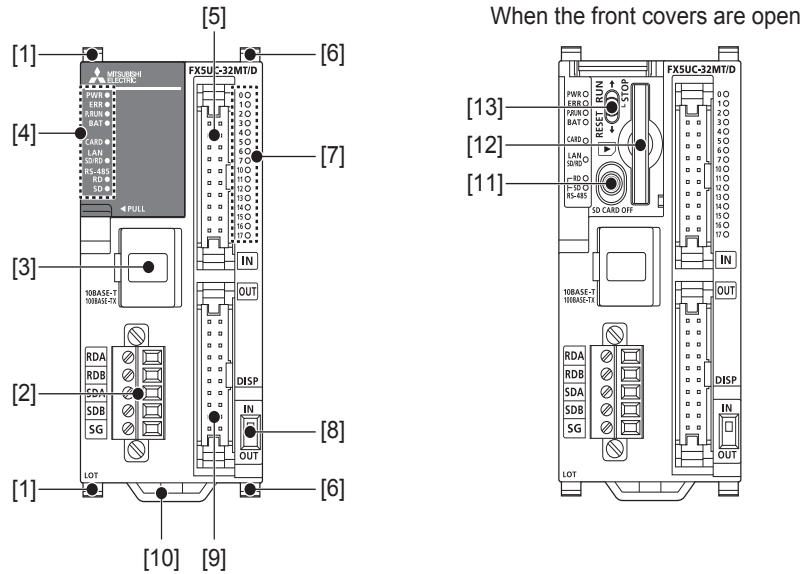

No.	Name	Description
[1]	Expansion adapter connecting hooks	When connecting an expansion adapter, secure it with these hooks.
[2]	Built-in RS-485 communication terminal block	Terminal block for connection with RS-485-compatible devices
[3]	Built-in Ethernet communication connector	Connector for connection with Ethernet-compatible devices (with cap) For details, refer to MELSEC iQ-F FX5 User's Manual (Ethernet Communication) .
[4]	Operation status display LED	
	PWR LED	Indicates whether the CPU module is powered or not. Lit: Powered Off: Not powered or hardware error (Page 101 Checking with LEDs)
	ERR LED	Indicates the error status of the CPU module. (Page 101 Checking with LEDs) Lit: Error or hardware error Flashing: Factory default setting, error, hardware error, or resetting Off: Operating normally
	P.RUN LED	Indicates the program running status. Lit: Operating normally Flashing: Paused Off: Stopped or stop error
	BAT LED	Indicates the battery status. Flashing: Battery error Off: Operating normally (Page 101 Checking with LEDs)
	CARD LED	Indicates whether an SD memory card can be used or not. Lit: Can be used or cannot be removed. Flashing: In preparation Off: Not inserted or can be removed.
	SD/RD LED	Lit when the CPU module is sending or receiving data through built-in Ethernet communication.
	RD LED	Lit when the CPU module is receiving data through built-in RS-485 communication.
	SD LED	Lit when the CPU module is sending data through built-in RS-485 communication.
[5]	Input connector	Connector for connecting input signal cables.
[6]	Extension module connecting hook	When connecting an expansion module, secure it with these hooks.
[7]	I/O display LED	Lit when the input or output is on.
[8]	DISP switch	Switches input/output of the I/O display LED.

No.	Name	Description
[9]	Output connector	Connector for connecting output signal cables.
[10]	DIN rail mounting hook	Hook for mounting a CPU module on a DIN rail of DIN46277 (35 mm (1.38") wide).
[11]	SD memory card disable switch	Switch for disabling access to the SD memory card when the card is to be removed.
[12]	SD memory card slot	Slot for inserting an SD memory card.
[13]	RUN/STOP/RESET switch	Switch for operating the CPU module. (☞ Page 95 Methods of running, stopping, and resetting) RUN: Runs the program STOP: Stops the program RESET: Resets the CPU module (hold the switch on the RESET side for approximately 1 second.)

Side

Left side/right side

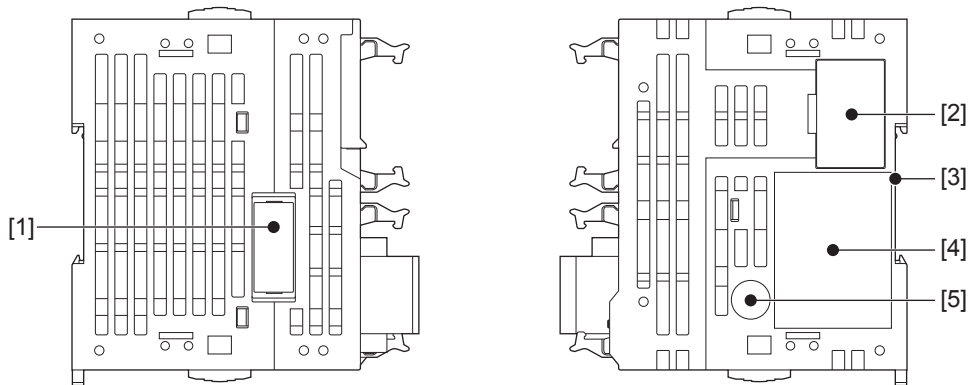

No.	Name	Description
[1]	Expansion adapter connector cover	Cover for protecting the expansion adapter connector.
[2]	Subsequent extension connector cover	Cover for protecting the subsequent extension connector.
[3]	DIN rail mounting groove	The module can be installed on a DIN46277 rail (35 mm (1.38") wide).
[4]	Nameplate	The product model name, manufacturer's serial number, power supply specifications, and MAC address are shown.
[5]	Genuine product certification label	Genuine product certification label to prevent counterfeiting



Products that do not have the genuine product certification label or nameplate are not covered by the warranty.

Bottom side

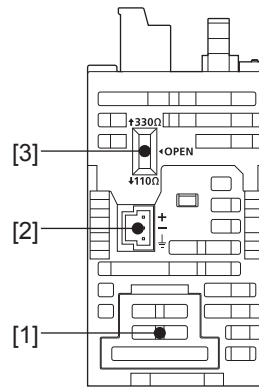

No.	Name	Description
[1]	Battery cover	Cover for protecting the battery connecting connector.
[2]	Power connector for CPU module	Connector for connecting power cables.
[3]	RS-485 terminal resistor selector switch	Switch for switching terminal resistance for built-in RS-485 communication.

Point



Use a tool such as a screwdriver to operate the RS-485 terminal resistance selector switch. Make sure that the tip of a tool does not damage the switch or case.

2 SPECIFICATIONS

The CPU module specifications are explained below.

2.1 Generic Specifications

Item	Specifications				
Operating ambient temperature* ¹	0 to 55°C (32 to 131 °F)* ²				
Storage ambient temperature	-25 to 75°C (-13 to 167 °F)				
Operating ambient humidity	5 to 95%RH, non-condensation				
Storage ambient humidity	5 to 95%RH, non-condensation				
Vibration resistance* ^{3,4}	—	Frequency	Acceleration	Half amplitude	Sweep count
	Installed on DIN rail	5 to 8.4 Hz	—	1.75 mm	10 times each in X, Y, Z directions (80 min in each direction)
		8.4 to 150 Hz	4.9 m/s ²	—	
Shock resistance* ³	147 m/s ² , Action time: 11 ms, 3 times by half-sine pulse in each direction X, Y, and Z				
Noise durability	By noise simulator at noise voltage of 1000 Vp-p, noise width of 1 μs and period of 30 to 100 Hz				
Grounding	Class D grounding (grounding resistance: 100 Ω or less) <Common grounding with a heavy electrical system is not allowed.>* ⁵				
Working atmosphere	Free from corrosive or flammable gas and excessive conductive dust				
Operating altitude* ⁶	0 to 2000 m				
Installation location	Inside a control panel				
Overvoltage category* ⁷	II or less				
Pollution degree* ⁸	2 or less				
Equipment class	Class 2				

- *1 The simultaneous ON ratio of available PLC inputs or outputs changes with respect to the ambient temperature, refer to  Page 20 Input/Output Derating Curve.
- *2 For details on Intelligent function modules, refer to manuals of each product.
- *3 The criterion is shown in IEC61131-2.
- *4 When the system has equipment which specification values are lower than above mentioned vibration resistance specification values, the vibration resistance specification of the whole system is corresponding to the lower specification.
- *5 For grounding, refer to  Page 56 Grounding.
- *6 The PLC cannot be used at a pressure higher than the atmospheric pressure to avoid damage.
- *7 This indicates the section of the power supply to which the equipment is assumed to be connected between the public electrical power distribution network and the machinery within premises. Category II applies to equipment for which electrical power is supplied from fixed facilities. The withstand surge voltage for the equipment with the rated voltage up to 300 V is 2500 V.
- *8 This index indicates the degree to which conductive material is generated in the environment in which the equipment is used. Pollution level 2 is when only non-conductive pollution occurs. Temporary conductivity caused by condensation must be expected occasionally.

Dielectric withstand voltage test and insulation resistance test

Perform dielectric withstand voltage test and insulation resistance test at the following voltages between each terminal and the CPU module ground terminal.

■ CPU module, I/O module

Between terminals	Dielectric withstand voltage	Insulation resistance	Remarks
Between power supply terminal (24 V DC) and ground terminal	500 V AC for one minute	10 MΩ or higher by 500 V DC insulation resistance tester	—
Between input terminal (24 V DC) and ground terminal			—
Between output terminal (transistor) and ground terminal			—
Between output terminal (relay) and ground terminal	1.5 kV AC for one minute		I/O module only

■Expansion adapter

For information concerning the dielectric withstand voltage and insulation resistance of each expansion adapter, refer to manuals of each expansion adapter.

■Intelligent function module

For information concerning dielectric withstand voltage and insulation resistance of each intelligent function module, refer to manuals of each intelligent function module.

2.2 Power Supply Specifications

The CPU module power supply specifications are explained below.

For the consumption current of each extension module, refer to  Page 26 PRODUCT LIST or manuals of each extension module.

DC power supply

Item	Specifications
Power supply voltage	24 V DC
Allowable voltage range	20.4 to 28.8 V DC
Allowable instantaneous power failure time	Operation can be continued upon occurrence of instantaneous power failure for 5 ms or less.
Power fuse	125 V, 3.15 A Time-lag fuse
Rush current	30 A max. 0.5 ms or less/24 V DC
Power consumption*1	8 W [30 W]
5 V DC power supply capacity	720 mA
24 V DC power supply capacity	500 mA

*1 This item shows value when only the CPU module is used.

The value in [] is the value in the maximum configuration connectable to the CPU module. (The value does not include the external 24 V DC power supply of extension devices)

2.3 Input Specifications

The CPU module input specifications are explained below.

24 V DC input (sink/source)

Input numbers in the table indicate the CPU module numbers.

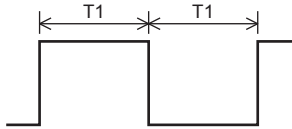
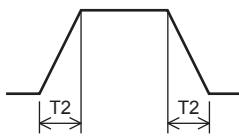
Item	Specifications		
No. of input points	16 points		
Connection type	Connector		
Input type	FX5UC-32MT/D	Sink	
	FX5UC-32MT/DSS	Sink/source	
Input signal voltage	24 V DC +20%, -15%		
Input signal current	5.3 mA/24 V DC		
Input impedance	4.3 k Ω		
ON input sensitivity current	3.5 mA or more		
OFF input sensitivity current	1.5 mA or less		
Input response frequency	X000 to X005	200 kHz When capturing pulses of a response frequency of 50 to 200 kHz, refer to  Page 62 When a high-speed pulse is captured.	
	X006 to X017	10 kHz	
Pulse waveform	Waveform		
		T1 (pulse width)	T2 (rise/fall time)
	X000 to X005	2.5 μ s or more	1.25 μ s or less
	X006 to X017	50 μ s or more	25 μ s or less
Input response time (H/W filter delay)	X000 to X005	ON: 2.5 μ s or less OFF: 2.5 μ s or less	
	X006 to X017	ON: 30 μ s or less OFF: 50 μ s or less	
Input response time (Digital filter setting value)	None, 10 μ s, 50 μ s, 0.1 ms, 0.2 ms, 0.4 ms, 0.6 ms, 1 ms, 5 ms, 10 ms (initial value), 20 ms, 70 ms When using this product in an environment with much noise, set the digital filter.		

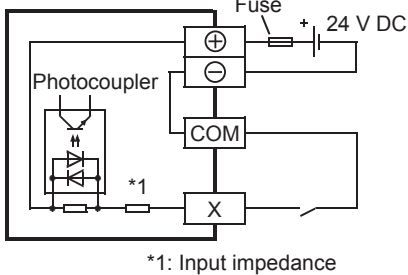
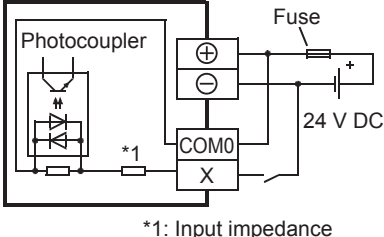
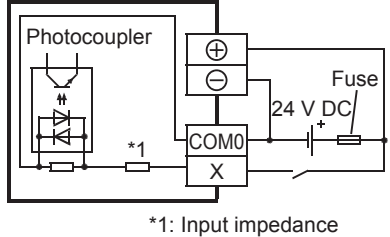
Item		Specifications
Input signal format	FX5UC-32MT/D	No-voltage contact input NPN open collector transistor
	FX5UC-32MT/DSS	No-voltage contact input Sink: NPN open collector transistor Source: PNP open collector transistor
Input circuit insulation		Photo-coupler insulation
Indication of input operation		LED is lit when input is on (DISP switch: IN)
Input signal format	FX5UC-32MT/D	 <p>*1: Input impedance</p>
	FX5UC-32MT/DSS	<p>• Sink input wiring</p>  <p>*1: Input impedance</p>
		<p>• Source input wiring</p>  <p>*1: Input impedance</p>

2.4 Output Specifications

The CPU module output specifications are explained below.

Transistor output

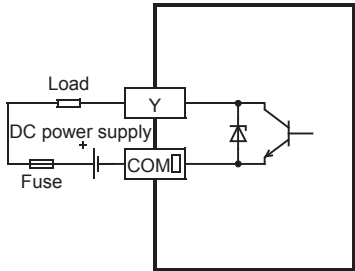
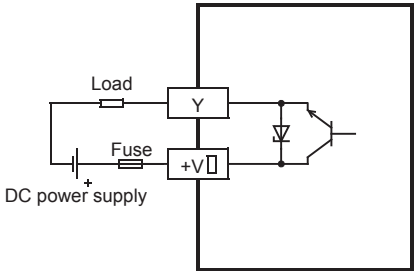
Item	Output specifications		
No. of output points	16 points		
Connection type	Connector		
Output type	FX5UC-32MT/D	Transistor/sink output	
	FX5UC-32MT/DSS	Transistor/source output	
External power supply	5 to 30 V DC		
Max. load	Y000 to Y003	0.3 A/point	The total load current per common terminal should be the following value. • 8 output points/common terminal: 0.8 A or less*1 For details of the common, refer to  Page 25 Terminal Layout.
	Y004 and subsequent	0.1 A/point	
Open circuit leakage current	0.1 mA or less/30 V DC		
Voltage drop when ON	Y000 to Y003	1.0 V or less	
	Y004 and subsequent	1.5 V or less	
Response time	Y000 to Y003	2.5 μs or less/10 mA or more (5 to 24 V DC)	
	Y004 and subsequent	0.2 ms or less/100 mA (24 V DC)	
Insulation of circuit	Photo-coupler insulation		
Indication of output operation	LED is lit when output is on (DISP switch: OUT)		
Output circuit configuration	<div style="display: flex; justify-content: space-around;"> <div style="text-align: center;"> <p>Sink output wiring</p>  <p>A common number is input in the <input type="checkbox"/> of [COM].</p> </div> <div style="text-align: center;"> <p>Source output wiring</p>  <p>A common number is input in the <input type="checkbox"/> of [+V].</p> </div> </div>		

*1 When two common terminals are connected outside the CPU module, resistance load is 1.6A or less.

2.5 Input/Output Derating Curve

The derating curve below shows the simultaneous ON ratio of available PLC inputs or outputs with respect to the ambient temperature. Use the PLC within the simultaneous input or output ON ratio range shown in the figure.

Derating curve

Simultaneous ON ratio

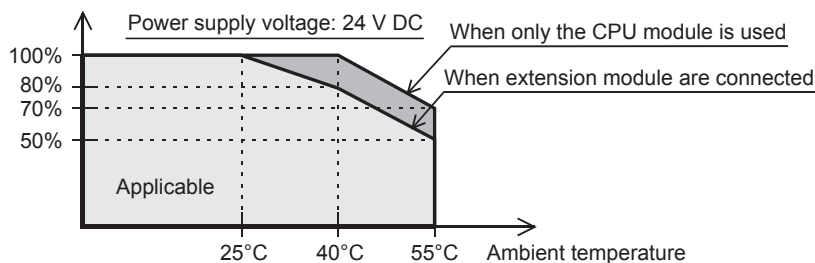

2.6 Performance Specifications

Item	Specifications	
Control system	Stored-program repetitive operation	
Input/output control system	Refresh system (Direct access input/output allowed by specification of direct access input/output [DX, DY])	
Programming specifications	Programming language	Ladder diagram (LD), structured text (ST), function block diagram/ladder diagram (FBD/LD)
	Programming extension function	Function block (FB), structured ladder, label programming (local/global)
	Constant scan	0.2 to 2000 ms (can be set in 0.1 ms increments)
	Fixed cycle interrupt	1 to 60000 ms (can be set in 1 ms increments)
	Timer performance specifications	100 ms, 10 ms, 1 ms
	No. of program executions	32
	No. of FB files	16 (Up to 15 for user)
Operation specifications	Execution type	Standby type, initial execution type, scan execution type, fixed-cycle execution type, event execution type
	Interrupt type	Internal timer interrupt, input interrupt, high-speed comparison match interrupt
Command processing time	LD X0	34 ns
	MOV D0 D1	34 ns
Memory capacity	Program capacity	64 k steps (128 kbytes, flash memory)
	SD memory card	Memory card capacity (SD/SDHC memory card: Max. 4 Gbytes)
	Device/label memory	120 kbytes
	Data memory/standard ROM	5 Mbytes
Flash memory (Flash ROM) write count	Maximum 20000 times	
File storage capacity	Device/label memory	1
	Data memory P: No. of program files FB: No. of FB files	P: 32, FB: 16
	SD Memory Card	2 Gbytes: 511 ^{*1} 4 Gbytes: 65534 ^{*1}
Clock function	Display data	Year, month, day, hour, minute, second, day of week (leap year automatic detection)
	Precision	-2.96 to +3.74 (TYP.+1.42) s/d (Ambient temperature: 0°C (32°F)) -3.18 to +3.74 (TYP.+1.50) s/d (Ambient temperature: 25°C (77°F)) -13.20 to +2.12 (TYP.-3.54) s/d (Ambient temperature: 55°C (131°F))
No. of input/output points	(1) No. of input/output points	256 points or less
	(2) No. of remote I/O points	384 points or less
	Total No. of points of (1) and (2)	512 points or less
Power failure retention ^{*2}	Retention method	Large-capacity capacitor
	Retention time	10 days (Ambient temperature: 25°C (77°F))
	Data retained	Clock data

*1 The value listed above indicates the number of files stored in the root folder.

*2 Clock data is retained using the power accumulated in a large-capacity capacitor incorporated into the PLC. When voltage of the large-capacity capacitor drops, clock data is no longer accurately retained. The retention period of a fully charged capacitor (electricity is conducted across the PLC for at least 30 minutes) is 10 days (ambient temperature: 25°C (77°F)). How long the capacitor can hold the data depends on the operating ambient temperature. When the operating ambient temperature is high, the holding period is short.

Number of device points

Item		Base	Max. number of points		
No. of user device points	Input relay (X)	8	1024 points	The total number of X and Y assigned to input/output points is up to 256 points.	
	Output relay (Y)	8	1024 points		
	Internal relay (M)	10	32768 points (can be changed with parameter) ^{*1}		
	Latch relay (L)	10	32768 points (can be changed with parameter) ^{*1}		
	Link relay (B)	16	32768 points (can be changed with parameter) ^{*1}		
	Annunciator (F)	10	32768 points (can be changed with parameter) ^{*1}		
	Link special relay (SB)	16	32768 points (can be changed with parameter) ^{*1}		
	Step relay (S)	10	4096 points (fixed)		
	Timer system	Timer (T)	10	1024 points (can be changed with parameter) ^{*1}	
	Accumulation timer system	Accumulation timer (ST)	10	1024 points (can be changed with parameter) ^{*1}	
	Counter system	Counter (C)	10	1024 points (can be changed with parameter) ^{*1}	
		Long counter (LC)	10	1024 points (can be changed with parameter) ^{*1}	
	Data register (D)		10	8000 points (can be changed with parameter) ^{*1}	
	Link register (W)		16	32768 points (can be changed with parameter) ^{*1}	
	Link special register (SW)		16	32768 points (can be changed with parameter) ^{*1}	
No. of system device points	Special relay (SM)	10	10000 points (fixed)		
	Special register (SD)	10	12000 points (fixed)		
Module access device	Intelligent function module device	10	65536 points (designated by U□\G□)		
No. of index register points	Index register (Z) ^{*2}	10	24 points		
	Long index register (LZ) ^{*2}	10	12 points		
No. of file register points	File register (R)	10	32768 points (can be changed with parameter) ^{*1}		
No. of nesting points	Nesting (N)	10	15 points (fixed)		
No. of pointer points	Pointer (P)	10	4096 points		
	Interrupt pointer (I)	10	178 points (fixed)		
Others	Decimal constant (K)	Signed	— 16 bits: -32768 to +32767, 32 bits: -2147483648 to +2147483647		
		Unsigned	— 16 bits: 0 to 65535, 32 bits: 0 to 4294967295		
	Hexadecimal constant (H)	— 16 bits: 0 to FFFF, 32 bits: 0 to FFFFFFFF			
	Real constant (E)	Single precision	— E-3.40282347+38 to E-1.17549435-38, 0, E1.17549435-38 to E3.40282347+38		
	Character string	— Shift-JIS code: Max. 255 single-byte characters (256 including NULL)			

*1 Can be changed with parameters within the capacity range of the CPU built-in memory.

*2 Total of the index register (Z) and long index register (LZ) is maximum 24 words.

2.7 Communication Specifications

The built-in Ethernet and built-in RS-485 communication specifications are as explained below.

Built-in Ethernet communication

For details of built-in Ethernet communication, refer to the following.

📖 MELSEC iQ-F FX5 User's Manual (Ethernet Communication)

📖 MELSEC iQ-F FX5 User's Manual (SLMP)

Item	Specifications	
Data transmission speed	100/10 Mbps	
Communication mode	Full-duplex (FDX)/ Half-duplex (HDX)	
Interface	RJ45 connector	
Transmission method	Base band	
Maximum segment length (The distance between hub and node)	100 m (328'1")	
Cascade connection	100BASE-TX	Cascade connection max. 2 stages*1
	10BASE-T	Cascade connection max. 4 stages*1
Protocol type	MELSOFT connection	
	SLMP (3E frame)	
	Socket communication	
	Predefined protocol support	
Number of simultaneously open connections allowed	Total of 8 for MELSOFT connection, SLMP, socket communication, and predefined protocol support (Up to 8 external devices can access one CPU module at the same time.)	
Insulation method	Pulse transformer insulation	
Cable used*2	For 100BASE-TX connection	Ethernet standard-compatible cable, category 5 or higher (STP cable)
	For 10BASE-T connection	Ethernet standard-compatible cable, category 3 or higher (STP cable)

*1 Number of stages that can be connected when a repeater hub is used. When a switching hub is used, check the specifications of the switching hub used.

*2 A straight cable can be used. If a personal computer or GOT and CPU module are directly connected a cross cable can be used.

Built-in RS-485 communication

For details of built-in RS-485 communication, refer to the following.

📖 MELSEC iQ-F FX5 User's Manual (Serial Communication)

📖 MELSEC iQ-F FX5 User's Manual (MODBUS Communication)

Item	Specifications
Transmission standards	Conforms to RS-485/RS-422 specifications
Data transmission speed	Max. 115.2 kbps
Communication method	Full-duplex (FDX) / Half-duplex (HDX)
Maximum total extension distance	50 m (164'0")
Protocol type	MELSOFT connection
	Non-protocol communication
	MELSEC Communication protocol (3C/4C frame)
	MODBUS RTU communication
	Predefined protocol support
	Inverter communication
	N:N Network
Insulation method	Not insulated
Terminal resistors	Built-in (OPEN/110 Ω/330 Ω)
Terminal block used	European-type terminal block

2.8 External Dimensions

FX5UC-32MT/D, FX5UC-32MT/DSS

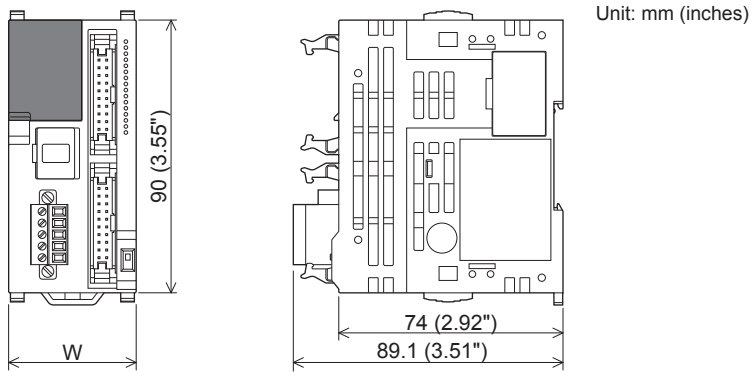

Model	W	Mass (weight)
FX5UC-32MT/D, FX5UC-32MT/DSS	42.1 mm (1.66")	Approx. 0.2 kg (0.44lbs)

- Exterior color

Main body: Munsell 0.6B7.6/0.2

- Accessories

Manual supplied with product

FX2NC-100MPCB power cable: 1 m (3'3")

FX2NC-100BPCB power cable: 1 m (3'3") (FX5UC-32MT/D only)

2.9 Terminal Layout

Built-in RS-485 terminal

European-type terminal block

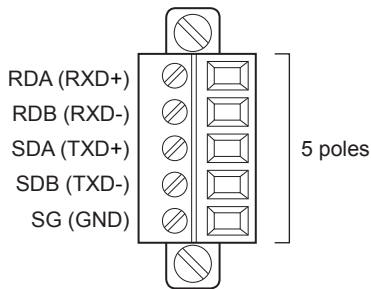

Built-in Ethernet connector

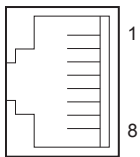

Pin	Signal name
1	TD+
2	TD-
3	RD+
4	Not used
5	Not used
6	RD-
7	Not used
8	Not used

Input/output connectors

FX5UC-32MT/D

FX5UC-32MT/DSS

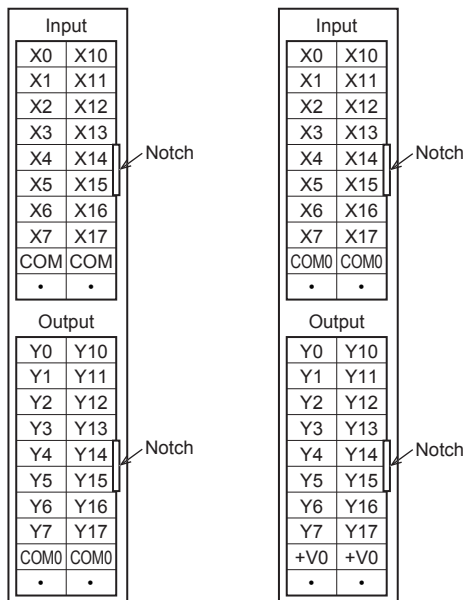

Power connector

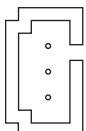

- 1 ⊕ (Red)
- 2 ⊖ (Black)
- 3 Ground (Green)

3 PRODUCT LIST

The following shows the system configuration equipment of the FX5UC.

3.1 Overall Configuration

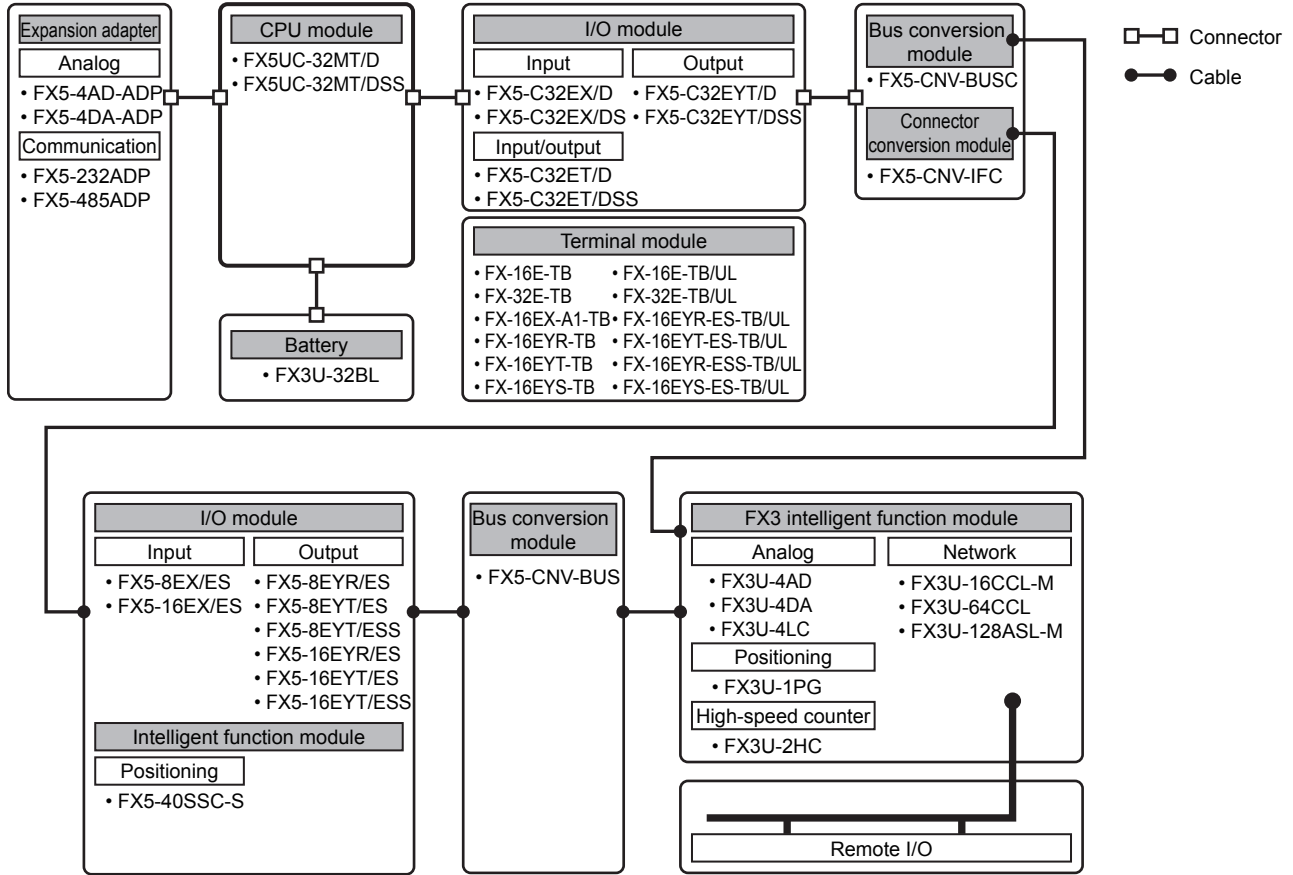

3.2 CPU Module

The CPU module incorporates a CPU, memory, input/output terminals, and power supply.

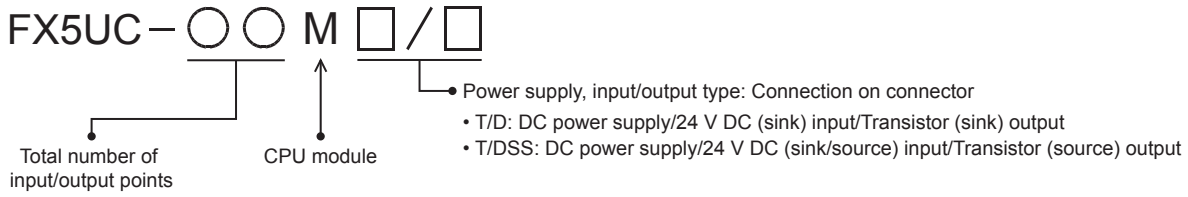

24 V DC sink and source input type

Model	No. of input/output points			Input type	Output type	Connection type	Power supply capacity	
	Total No. of points	No. of input points	No. of output points				5 V DC power supply	24 V DC power supply
FX5UC-32MT/D	32 points	16 points	16 points	24 V DC (sink)	Transistor (sink)	Connector	720 mA	500 mA
FX5UC-32MT/DSS				24 V DC (sink/source)	Transistor (source)			

Point 

The model name of the CPU module can be checked on the nameplate on the right side. After extension devices are connected, the nameplate cannot be seen. Check the model name in the following places.

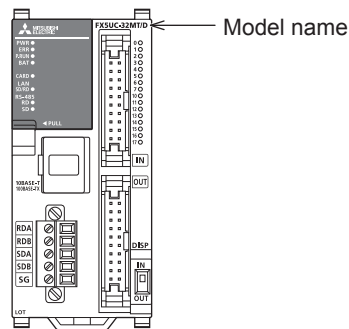

3.3 Extension Module

Extension modules are used to expand inputs/outputs, functions, and others.

The two connection types, extension connector type and extension cable type, are provided for extension modules.

- Extension connector type
- Extension cable type

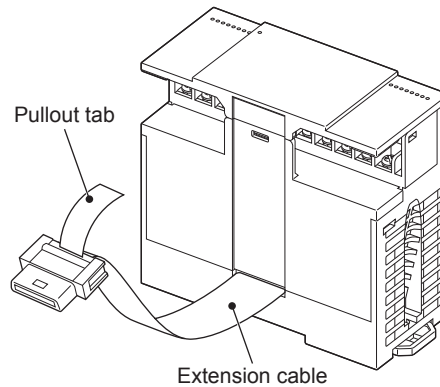
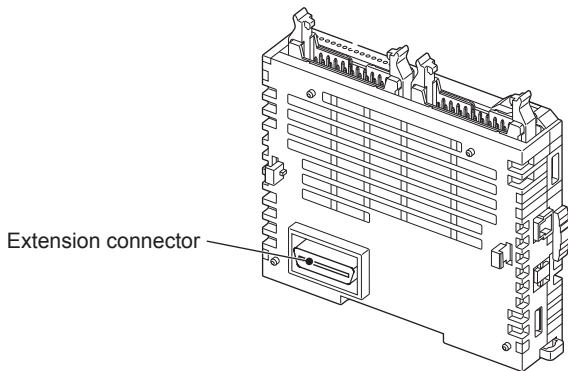

I/O module

I/O modules are used to expand inputs/outputs.

For details, refer to [Page 112 I/O Module](#).

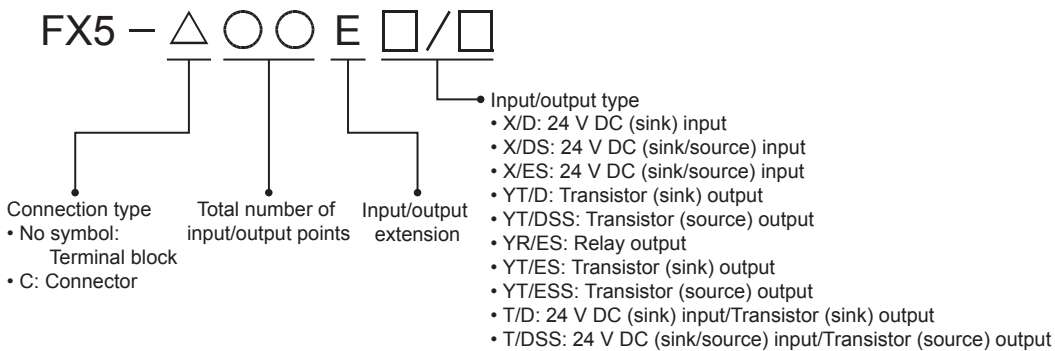

Input module

Input modules are used to expand inputs.

■ Extension connector type

Model	Number of input/output points			Input type	Output type	Connection type	Current consumption		
	Total No. of points	No. of input points	No. of output points				5 V DC power supply	24 V DC power supply	External 24 V DC power supply (24 V DC power supply for input circuits)
FX5-C32EX/D	32 points	32 points	—	24 V DC (sink)	—	Connector	120 mA	—	130 mA
FX5-C32EX/DS				24 V DC (sink/source)					

■ Extension cable type

Model	Number of input/output points			Input type	Output type	Connection type	Current consumption	
	Total No. of points	No. of input points	No. of output points				5 V DC power supply	24 V DC power supply
FX5-8EX/ES	8 points	8 points	—	24 V DC (sink/source)	—	Terminal block	75 mA	(50 mA) ^{*1}
FX5-16EX/ES	16 points	16 points	—				100 mA	(85 mA) ^{*1}

*1 Since external power supply is used for input circuit in FX5UC CPU module systems, power supply from CPU module is not included.

Output module

Output modules are used to expand outputs.

■ Extension connector type

Model	Number of input/output points			Input type	Output type	Connection type	Current consumption	
	Total No. of points	No. of input points	No. of output points				5 V DC power supply	24 V DC power supply
FX5-C32EYT/D	32 points	—	32 points	—	Transistor (sink)	Connector	120 mA	200 mA
FX5-C32EYT/DSS					Transistor (source)			

■ Extension cable type

Model	Number of input/output points			Input type	Output type	Connection type	Current consumption	
	Total No. of points	No. of input points	No. of output points				5 V DC power supply	24 V DC power supply
FX5-8EYR/ES	8 points	—	8 points	—	Relay	Terminal block	75 mA	75 mA
FX5-8EYT/ES					Transistor (sink)			
FX5-8EYT/ESS					Transistor (source)			
FX5-16EYR/ES	16 points	—	16 points	—	Relay	Terminal block	100 mA	125 mA
FX5-16EYT/ES					Transistor (sink)			
FX5-16EYT/ESS					Transistor (source)			

Input/output module

Input/output modules are used to expand inputs/outputs.

Model	Number of input/output points			Input type	Output type	Connection type	Current consumption		
	Total No. of points	No. of input points	No. of output points				5 V DC power supply	24 V DC power supply	External 24 V DC power supply (24 V DC power supply for input circuits)
FX5-C32ET/D	32 points	16 points	16 points	24 V DC (sink)	Transistor (sink)	Connector	120 mA	100 mA	65 mA
FX5-C32ET/DSS				24 V DC (sink/source)	Transistor (source)				

Intelligent function module

Intelligent function modules, such as simple motion modules, have functions other than input/output.

For details, refer to manuals of each module.

FX5 intelligent function module

The following FX5 intelligent function module can be used in FX5UC CPU module systems using connector conversion modules.

For the connector conversion modules to be connected, refer to  Page 31 Connector conversion module.

■Positioning

Model	Function	No. of occupied input/output points	Current consumption		
			5 V DC power supply	24 V DC power supply	External 24 V DC power supply
FX5-40SSC-S	4-axis control (compatible with SSCNET III/H)	8 points	—	—	250 mA

FX3 intelligent function module

The following FX3 intelligent functions modules can be used in FX5UC CPU module systems by using bus conversion modules.

For the bus conversion modules to be connected, refer to  Page 31 Bus conversion module.

To use the modules, refer to  Page 35 Bus conversion module.

■Analog

Model	Function	No. of occupied input/output points	Current consumption		
			5 V DC power supply	24 V DC power supply	External 24 V DC power supply
FX3U-4AD	4-CH voltage/current input	8 points	110 mA	—	90 mA
FX3U-4DA	4-CH voltage/current output		120 mA	—	160 mA
FX3U-4LC	4-CH temperature control (resistance thermometer/thermocouple/low voltage) 4 transistor output points		160 mA	—	50 mA

■Positioning

Model	Function	No. of occupied input/output points	Current consumption		
			5 V DC power supply	24 V DC power supply	External 24 V DC power supply
FX3U-1PG	Pulse output for independent 1-axis control	8 points	150 mA	—	40 mA

■High-speed counter

Model	Function	No. of occupied input/output points	Current consumption	
			5 V DC power supply	24 V DC power supply
FX3U-2HC	2-CH high-speed counter	8 points	245 mA	—

■Network

Model	Function	No. of occupied input/output points	Current consumption		
			5 V DC power supply	24 V DC power supply	External 24 V DC power supply
FX3U-16CCL-M ^{*1}	Master for CC-Link (compatible with Ver. 2.00 and Ver. 1.10)	8 points ^{*2}	—	—	240 mA
FX3U-64CCL ^{*1}	Intelligent device station for CC-Link	8 points	—	—	220 mA
FX3U-128ASL-M ^{*1*5}	Master for AnyWireASLINK	8 points ^{*3}	130 mA	—	100 mA ^{*4}

*1 GX Works3 does not support this module. When using this module, configure the settings with the buffer memory.

*2 The number of remote I/O points is added. For details, refer to  Page 39 Calculation of the number of remote I/O points.

*3 The number of input/output points set by the rotary switch is added. For details, refer to FX3U-128ASL-M USER'S MANUAL.

*4 This value does not include the supply current to slave modules. For details, refer to FX3U-128ASL-M USER'S MANUAL.

*5 Note that the warranty for this model differs from the ones for other PLCs. For details, refer to FX3U-128ASL-M USER'S MANUAL.

Bus conversion module

Bus conversion modules are used to connect FX3 intelligent functions modules in FX5UC CPU module systems. For details of the specifications of each bus conversion module, refer to the hardware manual of each product.

Model	Function	No. of occupied input/output points	Current consumption	
			5 V DC power supply	24 V DC power supply
FX5-CNV-BUSC	Bus conversion from CPU module or extension modules (extension connector type)	8 points	150 mA	—
FX5-CNV-BUS	Bus conversion from CPU module or extension modules (extension cable type) or FX5 intelligent function modules	8 points	150 mA	—

Connector conversion module

Connector conversion modules are used to connect FX5 I/O modules (extension cable type) or FX5 intelligent functions modules in FX5UC CPU module systems.

Model	Function	No. of occupied input/output points	Current consumption	
			5 V DC power supply	24 V DC power supply
FX5-CNV-IFC	Connector conversion from CPU module or extension modules (extension connector type)	—	—	—

3.4 Expansion Adapter

Expansion adapters are used to expand functions and are connected on the left side of the FX5UC CPU module. For details of the specifications of each expansion adapter, refer to the hardware manual of each product.

Model	Function	No. of occupied input/output points	Current consumption		
			5 V DC power supply	24 V DC power supply	External 24 V DC power supply
FX5-4AD-ADP	4-CH voltage/current input	—	10 mA	20 mA	—
FX5-4DA-ADP	4-CH voltage/current output	—	10 mA	—	160 mA
FX5-232ADP	For RS-232C communication	—	30 mA	30 mA	—
FX5-485ADP	For RS-485 communication	—	20 mA	30 mA	—

3.5 Terminal Module

For details of the terminal modules, refer to  Page 125 Terminal Module.

Model	Function	No. of occupied input/output points	Current consumption		
			5 V DC power supply	24 V DC power supply	External 24 V DC power supply
FX-16E-TB	Directly connected to the I/O connector of a PLC.	—	—	—	112 mA
FX-32E-TB		—	—	—	112 mA/16 points
FX-16EX-A1-TB	100 V AC input type	—	—	—	48 mA
FX-16EYR-TB	Relay output type	—	—	—	80 mA
FX-16EYT-TB	Transistor output type (sink output)	—	—	—	112 mA
FX-16EYS-TB	Triac output type	—	—	—	112 mA
FX-16E-TB/UL	Directly connected to the I/O connector of a PLC.	—	—	—	112 mA
FX-32E-TB/UL		—	—	—	112 mA/16 points
FX-16EYR-ES-TB/UL	Relay output type	—	—	—	80 mA
FX-16EYT-ES-TB/UL	Transistor output type (sink output)	—	—	—	112 mA
FX-16EYT-ESS-TB/UL	Transistor output type (source output)	—	—	—	112 mA
FX-16EYS-ES-TB/UL	Triac output type	—	—	—	112 mA

3.6 SD Memory Card

For details of the SD memory card, refer to  Page 123 SD Memory Card.

Model	Function
NZ1MEM-2GBSD	SD memory card (Mitsubishi product)
NZ1MEM-4GBSD	
L1MEM-2GBSD	
L1MEM-4GBSD	

3.7 Battery

For details of the battery, refer to  Page 97 Battery.

Model	Function
FX3U-32BL	Battery

3.8 Communication Cable

Use a communication cable to connect a PLC with a personal computer by RS-232C communication.

Model	Function
FX-232CAB-1	FX5-232ADP↔Personal computer

3.9 Engineering Tool

For design and programming of FX5UC CPU module systems, use GX Works3.

For the operation method, refer to the  GX Works3 Operating Manual.

Model	Function
GX Works3	MELSEC PLC software package

4 SYSTEM CONFIGURATION

Configuration of a whole system

The configuration of an entire system is shown below as an example.

For assignment of the module numbers for extension module, refer to  Page 42 Module number of Extension modules.

Ex.

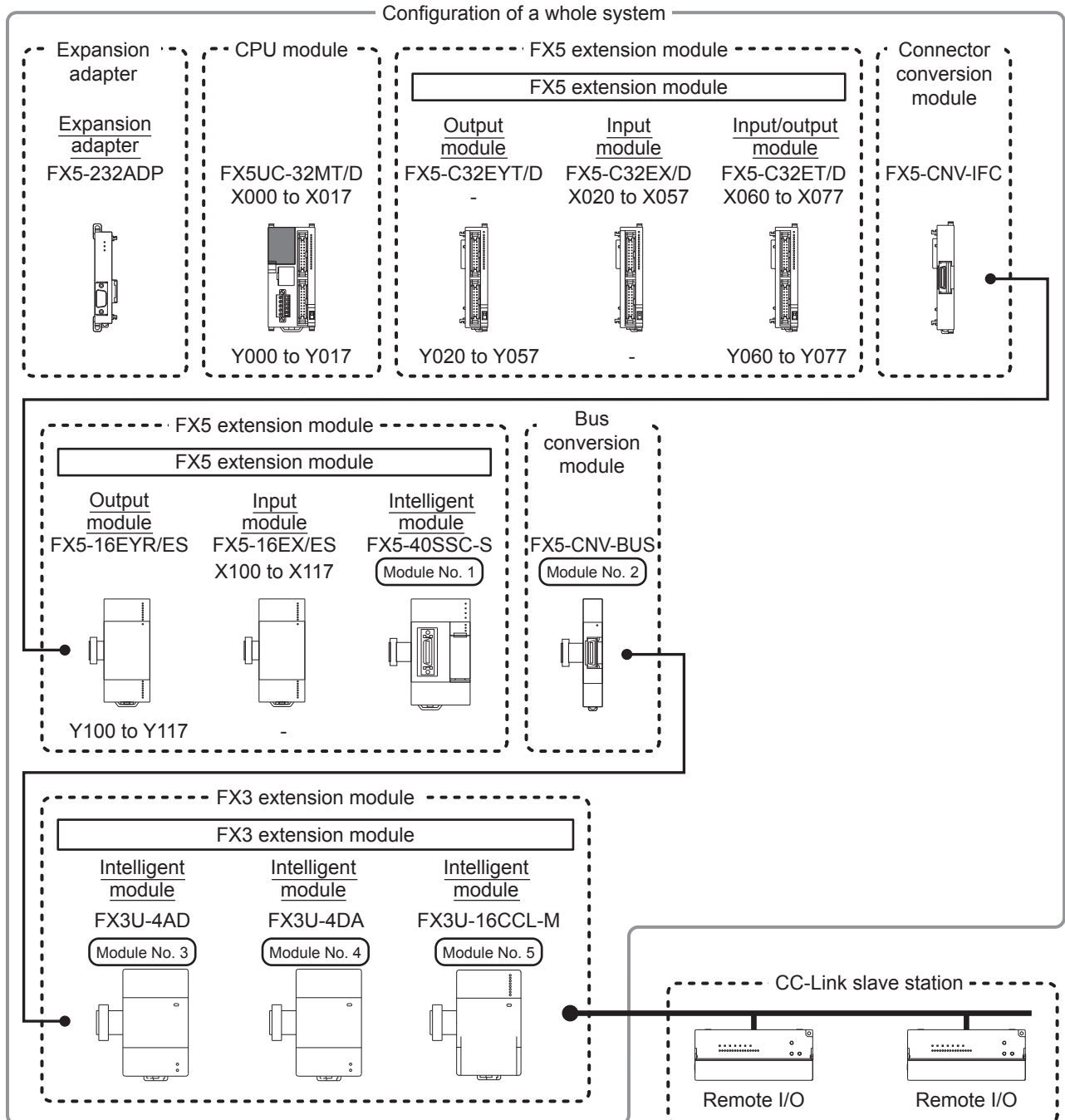

4.1 Rules of System Configuration

The system configuration must meet the following four requirements.

Number of connected extension devices

The number of extension devices that can be connected to a single system of FX5UC CPU modules is limited. For details, refer to [Page 36 Limitations on the Number of Connected Extension Devices](#).

Ex.

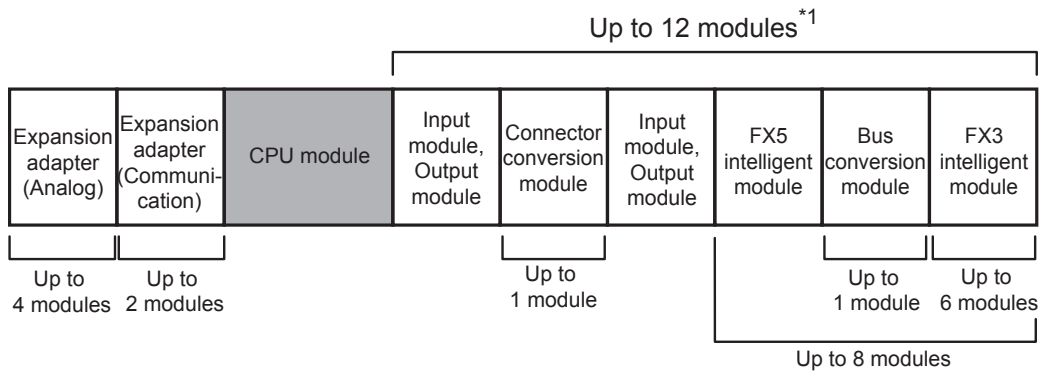

Number of input/output points

With the FX5UC CPU modules, a total of up to 512 points or less including the number of input/output points of extension devices (max. 256 points) and number of remote I/O points (max. 384 points) can be controlled. For details on the number of input/output points, refer to [Page 38 Limitation on the Number of Input/Output Points](#).

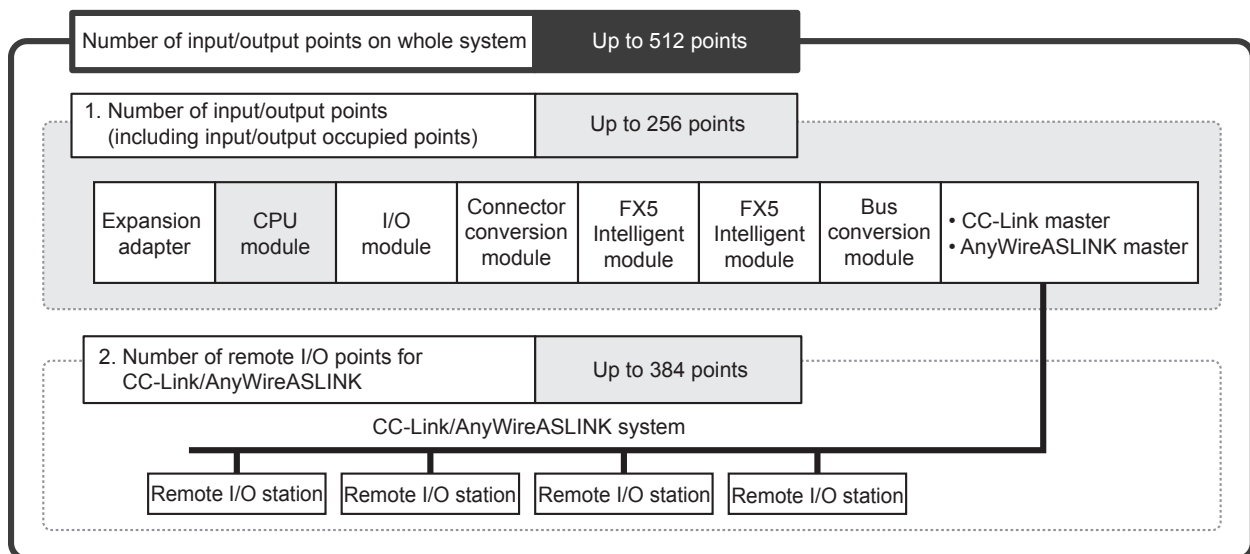

Current consumption

The power to the extension devices is supplied from a CPU module.

The number of extension devices that can be connected must be determined from the power supply capacity of the CPU module.

For details on the current consumption, refer to  Page 41 Limitation on Current Consumption.

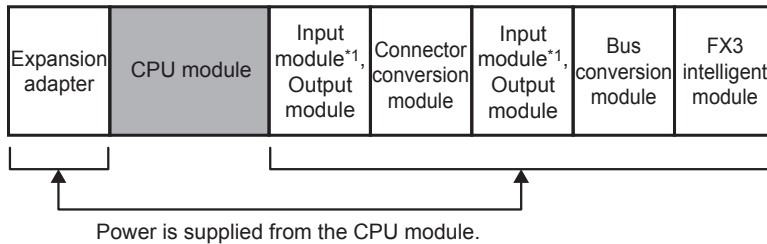

*1 The power to the input circuit of the input module is supplied from the external power supply.

Limitations when using FX3 extension devices

■ Bus conversion module

- A bus conversion module is required to use FX3 extension module. FX3 extension modules can be connected to the right side of the bus conversion module only.
- For limitations on the number of connected extension devices, refer to  Page 37 Connection to the bus conversion module (connection with FX3 extension devices).

■ Limitations on intelligent function modules

Note that some FX3 intelligent function modules have limitations on the number of modules and order in which they are added for each individual module.

Model	Limitation
FX3U-2HC	Up to two modules connectable per system. Connect a module of this type immediately after the bus conversion module.
FX3U-16CCCL-M	Only one module may be connected per system.
FX3U-64CCL	Only one module may be connected per system.
FX3U-128ASL-M	Only one module may be connected per system.

4.2 Limitations on the Number of Connected Extension Devices

Number of connected expansion adapters

There is a limitation on the number of expansion adapters connected to the FX5UC CPU module as follows.

Type	Limitation
Communication adapter	Up to 2 adapters can be connected
Analog adapter	Up to 4 adapters can be connected

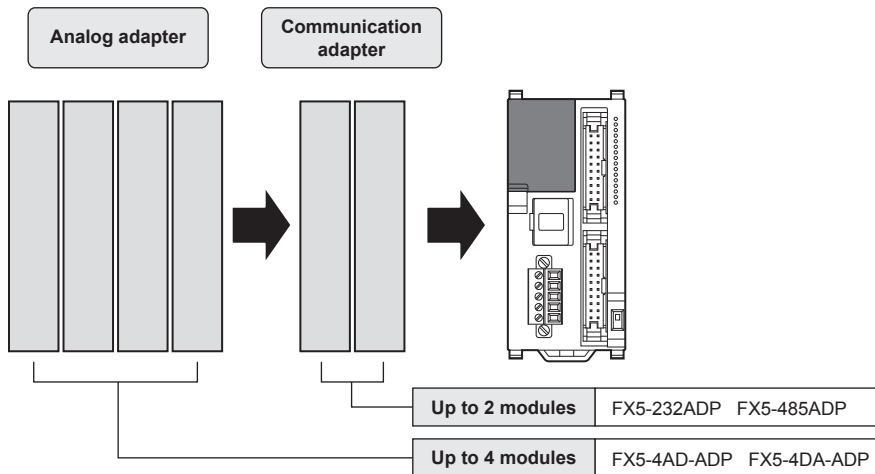

Number of connected extension modules

Overall system limitation

There is a limitation on the number of connected extension modules in a whole system as follows.

Type	Limitation
Extension module	Up to 12 modules can be connected to a system. (excluding connector conversion modules)
Connector conversion module	Only 1 module can be connected to a system.
Bus conversion module	Only 1 module can be connected to a system.

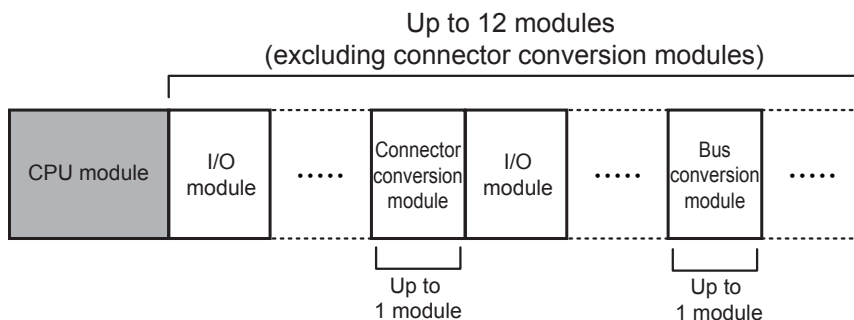

Connection to the CPU module

There is a limitation on the number of extension modules connected to the FX5UC CPU module as follows. The number of modules connected on the right side of the CPU module must be as follows.

Type	Limitation
Total No. of input modules, output modules, intelligent function modules, and bus conversion modules	Up to 12 modules can be connected.
Total No. of FX5 intelligent function modules, bus conversion module, FX3 intelligent function modules	Up to 8 modules can be connected.
Total No. of FX3 intelligent function modules	Up to 6 modules can be connected.

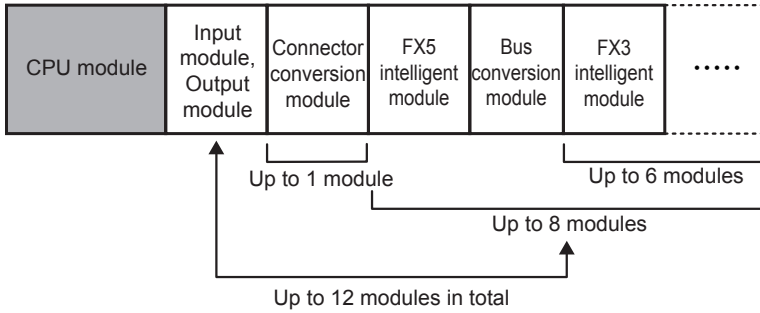

Connection to the bus conversion module (connection with FX3 extension devices)

There is a limitation on the number of extension modules connected to the bus conversion module as follows. The number of modules connected on the right side of the bus conversion module must be as follows.

Type	Limitation
Total No. of intelligent function modules	Up to 6 modules can be connected.

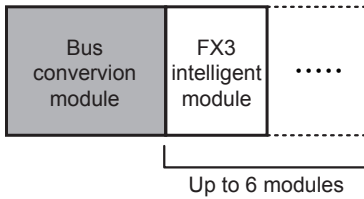

Precautions

FX5 extension modules cannot be connected on the right side of the bus conversion module.

4.3 Limitation on the Number of Input/Output Points

With the FX5UC CPU modules, a total of 512 points including the number of input/output points of extension devices (max. 256 points) and the number of remote I/O points (max. 384 points) can be controlled.

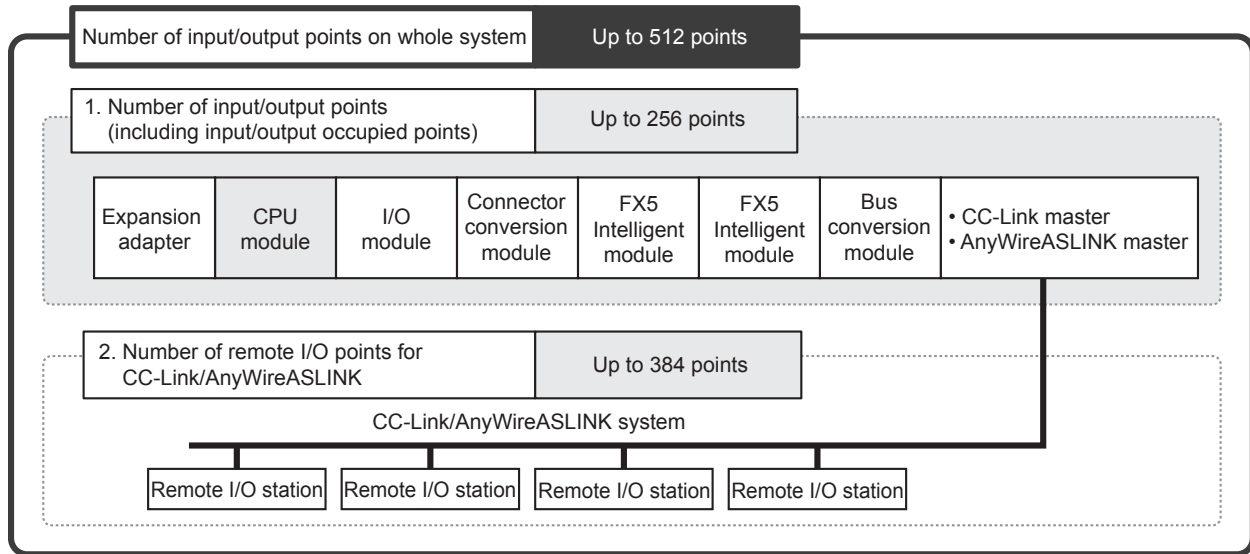

Total number of I/O points and remote I/O points

With the FX5UC CPU module, a total of 512 points or less including the number of input/output points of extension devices and number of remote I/O points can be controlled.

The total number of I/O points and remote I/O points must not exceed 512 points.

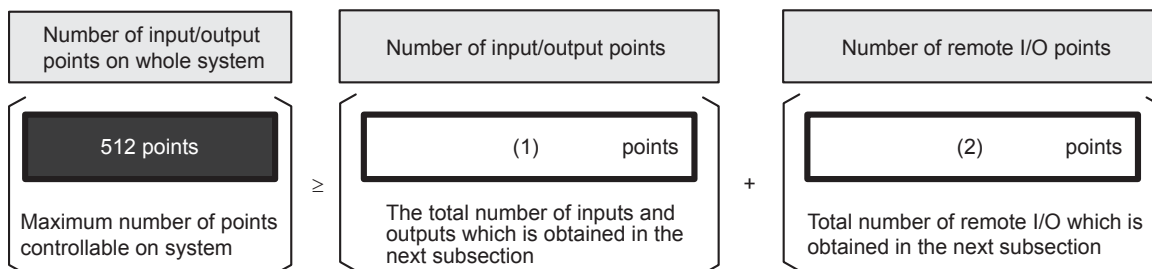

Calculation of the number of input/output points

The number of input/output points is a total of the number of input/output points of the CPU module, I/O module, and the number of occupied input/output points of intelligent function modules.

The total number of input/output points must not exceed 256 points.

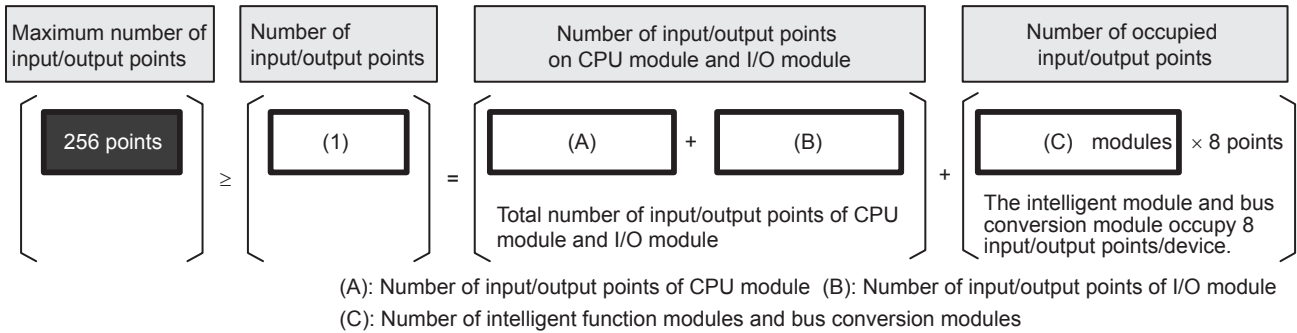

Total number of input/output points of the CPU module and I/O modules

Count the total number of input/output points of the CPU module and I/O modules.

To obtain the total number of input/output points, count the input points (X000 and more) and output points (Y000 and more) of the CPU module and I/O modules.

For details of the number of input/output points by models, refer to the following.

☞ Page 27 CPU Module

☞ Page 28 I/O module

Number of occupied input/output points of intelligent function modules

Count the number of occupied input/output points of intelligent function modules.

The number of occupied input/output points per module is 8.

For details on the number of occupied input/output points by models, refer to ☞ Page 30 Intelligent function module.

Calculation of the number of remote I/O points

If the master module of the network is used, calculate the number of remote I/O points connected on the network.

The total number of remote I/O points must not exceed 384 points.

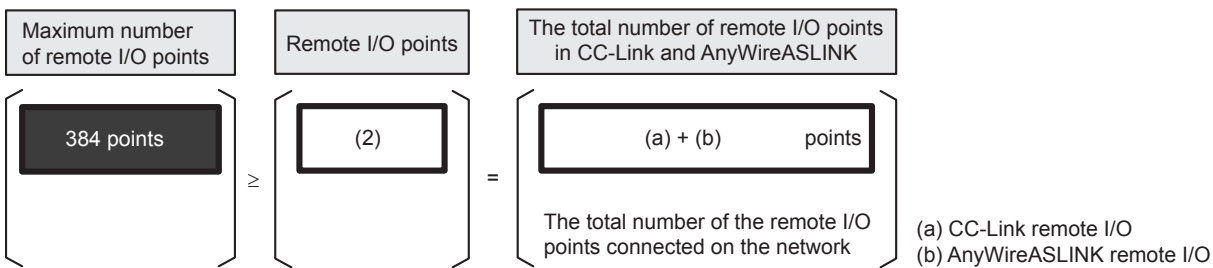

The maximum number of remote I/O points differs according to type of the network.

Precautions

Precautions when using CC-Link master (FX3U-16CCL-M) and AnyWireASLINK master (FX3U-128ASL-M) together

When using FX3U-16CCL-M and FX3U-128ASL-M together, connect FX3U-128ASL-M on the left side. In the FX5UC CPU module, FX3U-16CCL-M parameters are set up by PLC program and will occupy up to 256 remote I/O points. Therefore, the remote I/O points of FX3U-128ASL-M that is connected to the right side may be less than 128 points when FX3U-16CCL-M is connected to the left side.

Ex.

When input/output points are 160 points and CC-Link master are 256 points:

512 points - 160 points - 256 points = 96 points

Remote I/O points of the AnyWireASLINK master are 96 points or less.

CC-Link remote I/O

Remote I/O points that are used in FX3U-16CCL-M are calculated as "number of stations X 32 points".

Even if using less than 32 remote I/O points, calculate as "number of stations X 32 points".

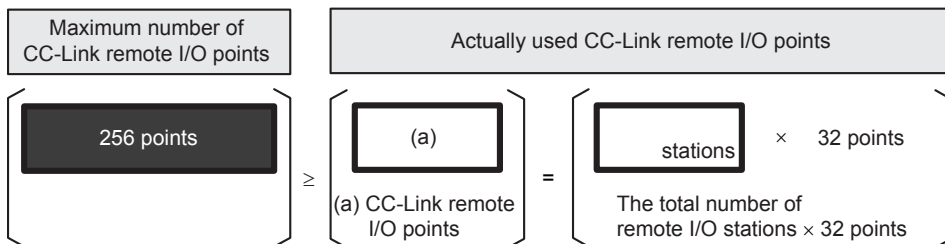

In the FX5UC CPU module, FX3U-16CCL-M parameters are set up by PLC program and will occupy up to 256 remote I/O points.

When the total number of the number of input/output points (including occupied input/output points) and the number of remote I/O points of FX3U-128ASL-M that is connected to the left side exceeds 256 points, the difference of 512 minus that total can be used as CC-Link remote I/O points.

AnyWireASLINK remote I/O

The number of input/output points set by the rotary switch of the AnyWireASLINK master is assigned as remote I/O of AnyWireASLINK.

Use the number of input/output points set by the rotary switch of the AnyWireASLINK master as the number of remote I/O points.

For details, refer to FX3U-128ASL-M USER'S MANUAL.

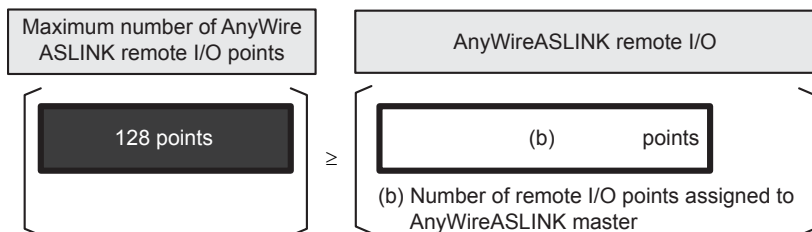

4.4 Limitation on Current Consumption

Power required for expansion adapters and extension modules is supplied from the CPU module. The number of extension devices that can be connected must be determined from the capacity of the power supply.

Power supply check from the CPU module (current consumption calculation)

Check if power can be supplied to extension devices with the power supply capacity of the CPU module.

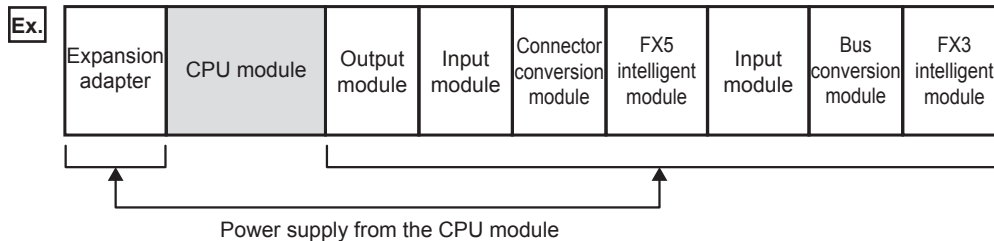

Calculate following the procedure below.

1. Check the power supply capacity of the CPU module used.

(☞ Page 27 CPU Module)

Ex.

Type	Model	Power supply capacity	
		5 V DC power supply	24 V DC power supply
CPU module	FX5UC-32MT/D	720 mA	500 mA

2. Check the current consumption of extension devices.

(☞ Page 28 Extension Module)

Ex.

Type	Model	Current consumption	
		5 V DC power supply	24 V DC power supply
Expansion adapter	FX5-232ADP	30 mA	30 mA
Output module	FX5-C32EYT/D	120 mA	200 mA
Input module	FX5-C32EX/D	120 mA	—
Connector conversion module	FX5-CNV-IFC	—	—
Simple motion module	FX5-40SSC-S	—	—
Input module	FX5-16EX/ES	100 mA	—
Bus conversion module	FX5-CNV-BUS	150 mA	—
Analog input	FX3U-4AD	110 mA	—

3. Calculate the total current consumption of each power supply.

Ex.

Power supply type	Total current consumption
5 V DC power supply	630 mA
24 V DC power supply	230 mA

4. Check if expansion to the CPU module is permitted.

- 5 V DC power supply

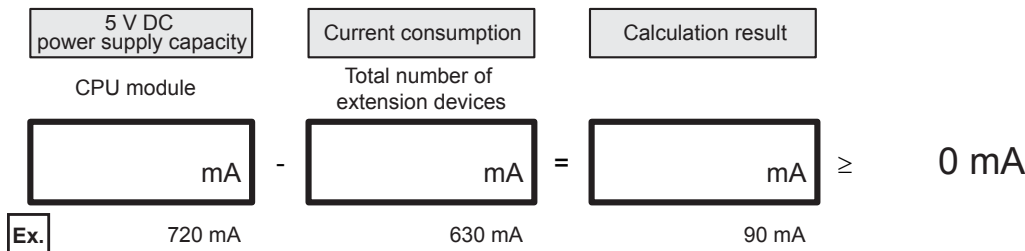

- 24 V DC power supply

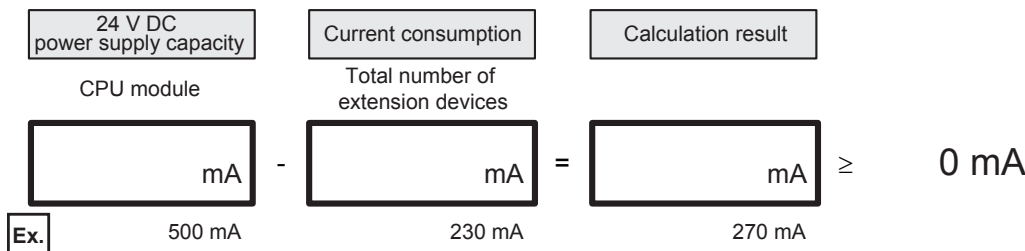

4.5 Numbers and Assignment in System

Input/output numbers and module numbers in an FX5UC system are explained.

Module input/output number

The input/output numbers are octal numbers. Input is assigned to "X" and output to "Y."

Input/output numbers are used for communication of ON/OFF data between I/O modules and the CPU module.

- Input/output numbers (X/Y) are octal.

Input/output numbers (X/Y) are automatically assigned as shown below.

X000 to X007, X010 to X017, X020 to X027, ... X070 to X077, X100 to X107, ...

Y000 to Y007, Y010 to Y017, Y020 to Y027, ... Y070 to Y077, Y100 to Y107, ...

- Numbers for added I/O module

To an added I/O module, input numbers and output numbers following the input numbers and output numbers given to the preceding device are assigned. The last digit of the assigned numbers must begin with 0.

Module number of Extension modules

The CPU module automatically assigns numbers (1 to 16) to intelligent function modules or bus conversion module as module numbers in order of distance from the CPU module.

- Intelligent function modules or bus conversion module connected to the CPU module

Module numbers are assigned to intelligent function modules in order of distance from the CPU module: No. 1 to No. 16.

- Products to which module numbers are not assigned

Module numbers are not assigned to the following extension devices.

- I/O module FX5-C32EX/D, FX5-C32EYT/D, etc.
- Expansion adapter FX5-232ADP, FX5-485ADP, etc.
- Connector conversion module FX5-CNV-IFC

Ex.

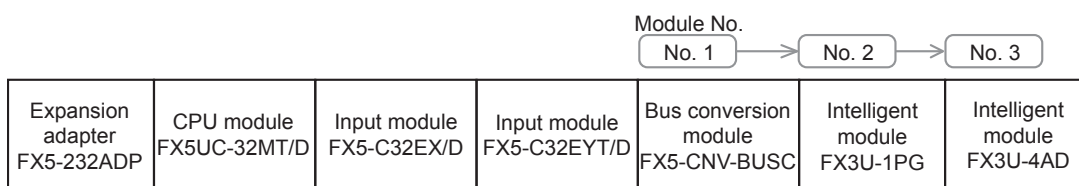

5 INSTALLATION

5.1 Installation Location

Use the PLC under the environmental conditions complying with the generic specifications (Page 17 Generic Specifications).

Installation location in enclosure

To prevent temperature rise, do not mount the PLC on the floor or ceiling, or in the vertical direction. Always mount the PLC horizontally on the wall as shown in the following figure.

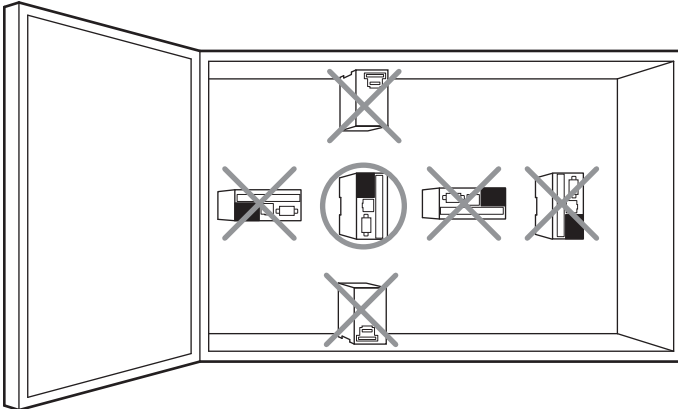

5

Spaces in enclosure

Extension devices can be connected on the left and right sides of the CPU module of the PLC. Keep a space of at least 50 mm (1.97") between the module main body and other devices and structure.

If you intend to add extension devices, keep necessary spaces on the left and right sides.

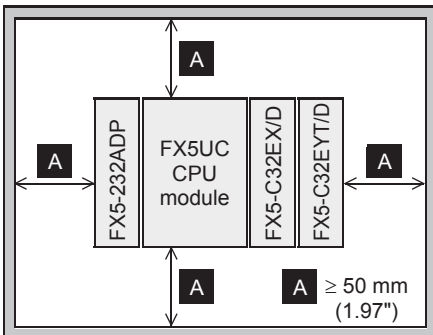

Layout in enclosure

Keep a space of at least 50 mm (1.97") between the module main body or other devices and structure.

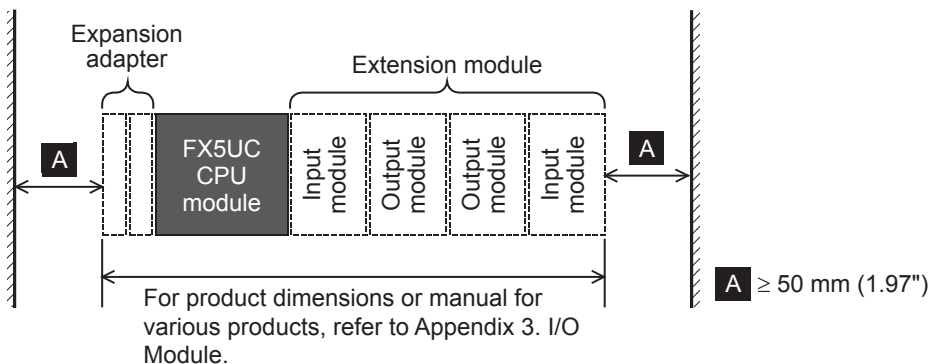

5.2 Examination for Installing Method in Enclosure

Examine the installation location of PLC considering the environmental conditions (☞ Page 17 Generic Specifications).

Point

When extension cables are used for the connection, install the products keeping a space of about 2 mm (0.08") between them.

Installing on DIN rail

- The PLC can be installed on a DIN46277 rail (35 mm (1.38") wide).
- The PLC can be easily moved and removed.
- The PLC installation height is the same as the DIN rail.

For details on the procedures for installing on and detaching from DIN rail, refer to ☞ Page 44 Procedures for Installing on and Detaching from DIN Rail.

■ Example of installation

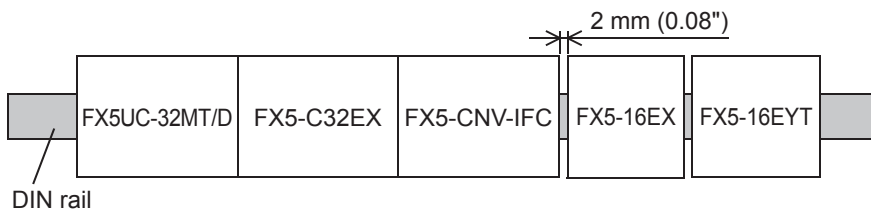

5.3 Procedures for Installing on and Detaching from DIN Rail

The CPU module can be installed on a DIN46277 rail (35 mm (1.38") wide).

Preparation for installation

Connecting extension devices

Some extension devices must be mounted on the CPU module before the module is installed in the enclosure.

- Connect expansion adapters or extension modules (extension connector type) on the CPU module before mounting the PLC in the enclosure.
- Mount extension modules (extension cable type) or terminal modules in the enclosure after mounting the CPU module in the enclosure.
- Mount (replace) a battery before mounting the CPU module.

Affixing the dust proof sheet

The dust proof sheet should be affixed to the ventilation slits before beginning the installation and wiring work.

For the affixing procedure, refer to the instructions on the dust proof sheet.

Always remove the dust proof sheet when the installation and wiring work is completed.

Installation of CPU module

Connect expansion adapters or extension modules (extension connector type) on the CPU module before mounting the PLC in the enclosure.

For the connection method of the expansion adapters, refer to [Page 47 Connecting method A - connection of an expansion adapter](#).

For the connection method of the extension modules (extension connector type), refer to [Page 47 Connecting method B - connection of an extension module \(extension connector type\)](#).

1. Push out all DIN rail mounting hooks (A in the following figure).

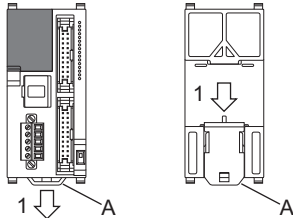

2. Fit the upper edge of the DIN rail mounting groove (B in the following figure) onto the DIN rail.

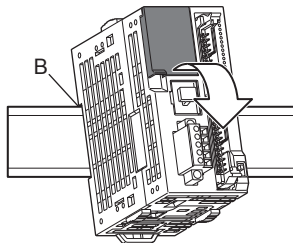

3. Lock the DIN rail mounting hooks (C in the following figure) while pressing the PLC against the DIN rail.

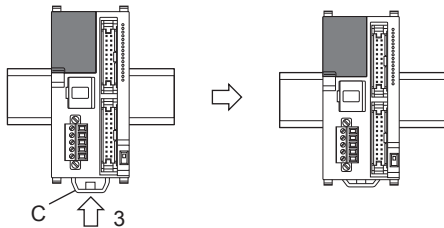

Installation of extension modules (extension cable type)

1. Push out the DIN rail mounting hook (A in the right figure) of the extension module (extension cable type).

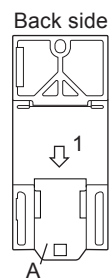

2. Fit the upper edge of the DIN rail mounting groove (B in the right figure) onto the DIN rail.
3. Push the product against the DIN rail.
4. Lock the DIN rail mounting hooks while pressing the product against the DIN rail.

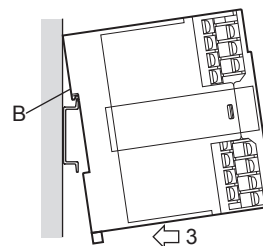

5. Connect the extension cable. For the connecting procedure of the extension cables, refer to [Page 46 Connecting Methods for CPU Module and Extension Devices](#).

Installation of terminal modules

1. Turn off all the power supplies connected to the CPU module, extension modules, or terminal modules.
2. Fit the upper edge of the DIN rail mounting groove (A in the right figure) onto the DIN rail.
3. Push the product against the DIN rail.

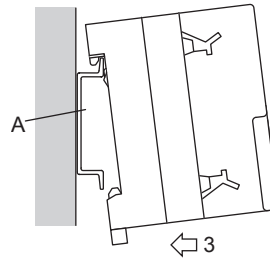

Removal of CPU module

1. Remove the connection cables including power cables and I/O cables.
2. Insert the tip of a flathead screwdriver into the hole of the DIN rail mounting hook (B in the right figure). This step also applies for the DIN rail mounting hooks of the expansion adapters or extension modules (connector type).
3. Move the flathead screwdriver as shown in the right figure to draw out the DIN rail mounting hooks of all devices.
4. Remove the product from the DIN rail (C in the right figure).
5. Push in the DIN rail mounting hooks (D in the right figure).

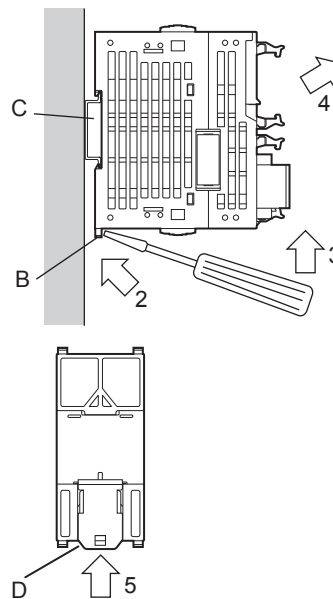

5.4 Connecting Methods for CPU Module and Extension Devices

This section explains the connection methods for extension devices.

Connection of extension devices

The connection method varies depending on the combination of products, i.e., the CPU module, expansion adapters, and extension modules.

The connecting methods are explained with the following configuration example.

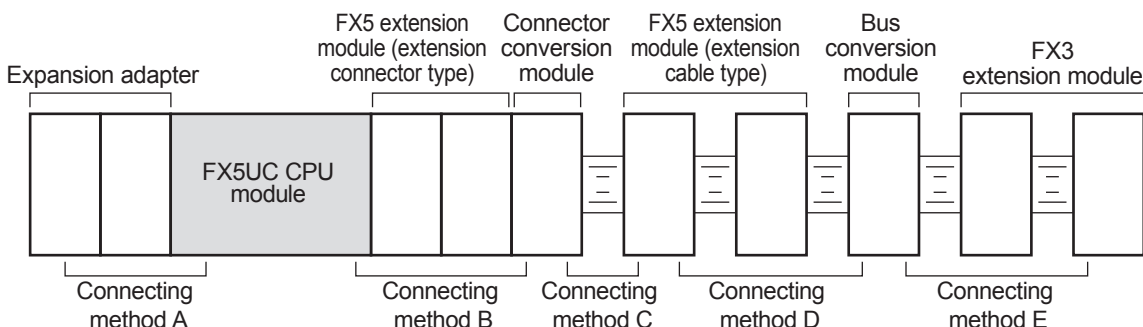

Connecting method A - connection of an expansion adapter

This subsection explains how to connect the expansion adapter to the CPU module.

1. Remove expansion adapter connector cover (A in the right figure).
2. Slide the hook for coupling the expansion adapter of the CPU module (B in the right figure).
3. Connect the expansion adapter to the CPU module as shown in the right figure.
4. Slide the hook for coupling the expansion adapter of the CPU module (B in the right figure) to fix the expansion adapter (C in the right figure).

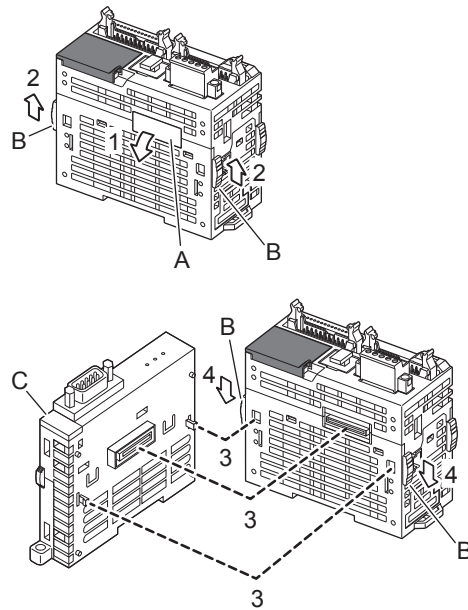

Connecting method B - connection of an extension module (extension connector type)

This subsection explains how to connect the extension module (extension connector type).

1. Slide the hook for coupling the extension module (A in the right figure) of the existing module (left side).
2. Remove the subsequent extension connector cover (B in the right figure).
3. Connect an extension module as shown in the right figure.
4. Slide the hook for coupling the extension module (A in the right figure) of the existing module to fix the extension module (C in the right figure).

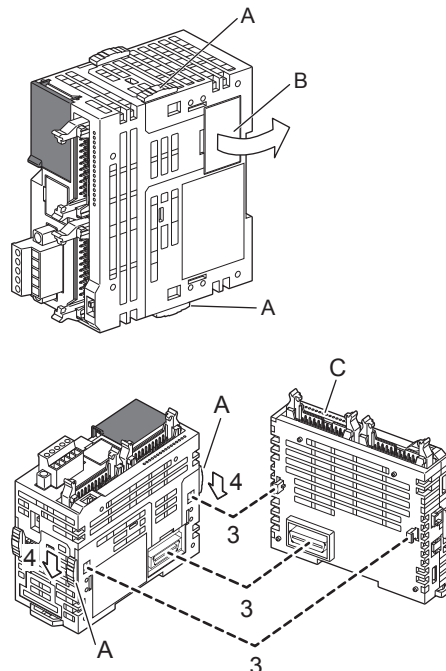

Connecting method C - connection of a connector conversion module (extension connector type) and an extension module (extension cable type)

This subsection explains how to connect the extension module (extension cable type) to the connector conversion module (extension connector type).

1. Connect the extension cable (A in the right figure) from the extension module (extension cable type) to the subsequent extension connector of the connector conversion module (extension connector type).

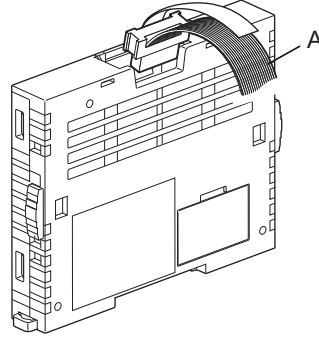

Point

Cautions on mounting and removing extension cables

- Make sure that the pullout tab of extension cables do not touch the conductive parts of the module.
- When removing the extension cable, pull the pullout tab of the extension cable straight up.

Connecting method D - connection between extension modules (extension cable type)

This subsection explains how to connect extension modules (extension cable type).

1. Remove the top cover (B in the right figure) of the existing module (left side) (A in the right figure).
2. Connect the extension cable (C in the right figure) of the module to be connected (right side) to the existing module (left side) (A in the right figure).
3. Fit the top cover (B in the right figure).
4. Draw out the pullout tab (D in the right figure) of the extension cable on the right side of the top cover.

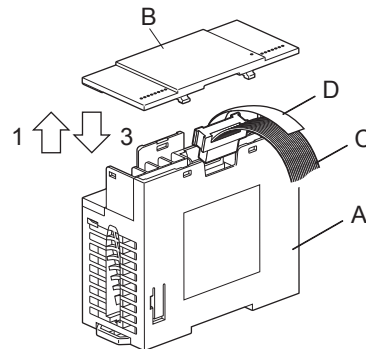

Point

Cautions on mounting and removing extension cables

- Make sure that the pullout tab of extension cables do not touch the conductive parts of the module.
- When removing the extension cable, pull the pullout tab of the extension cable straight up.

Connecting method E - connection of a bus conversion module and an FX3 intelligent function module

This subsection explains how to connect the FX3 extension module to the bus conversion module.

1. Connect the extension cable (A in the right figure) from the FX3 extension module to the subsequent extension connector of the bus conversion module.

This illustration is FX5-CNV-BUSC. When FX5-CNV-BUS is used, connect the extension cable to the bus conversion module in the same way.

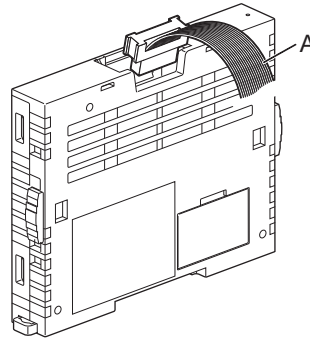

Connection of power cables

Power cable connection of the CPU module and I/O modules

The power must be supplied to the FX5UC CPU module, FX5-C32EX/D, and FX5-C32ET/D.

Use the power cable for CPU modules to supply the power to the FX5UC CPU module.

To supply the power to FX5-C32EX/D and FX5-C32ET/D, use two power connectors (upper and lower) on each module for crossover wiring.

FX5-C32EX/DS and FX5-C32ET/DSS do not have power connectors. Supply the power to them using input connectors.

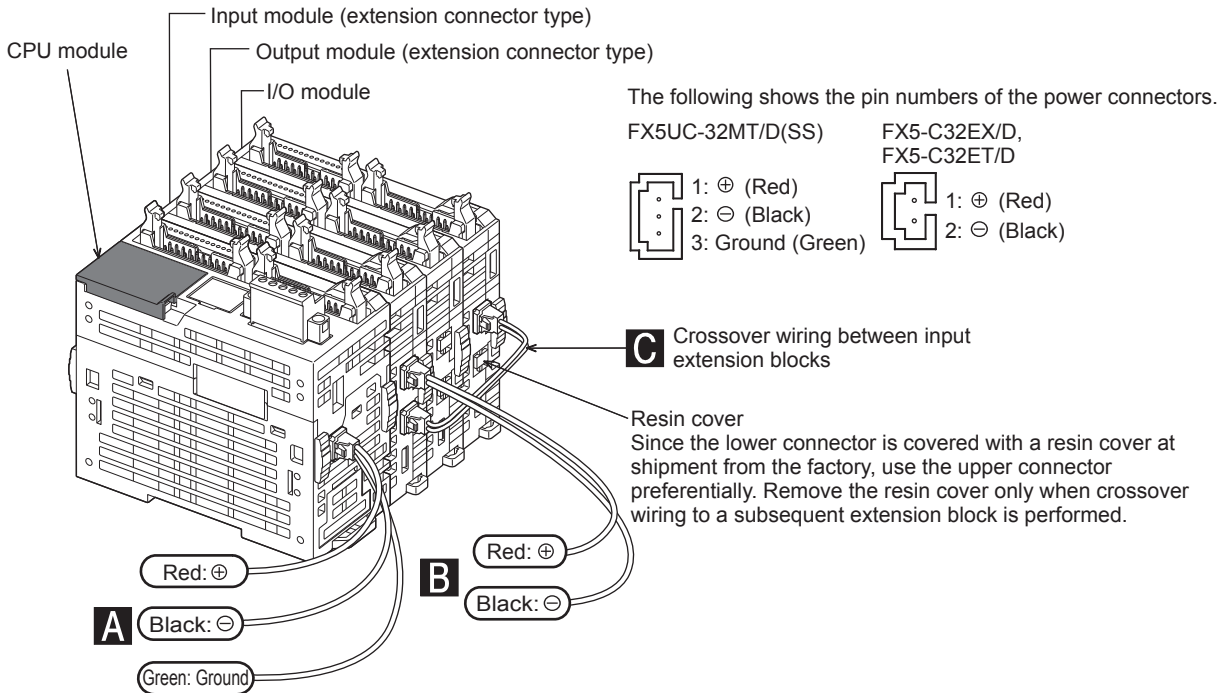

The following products are provided with power cables.

Classification	Application	Model	Length	Provided with
A	Power cable for CPU modules	FX2NC-100MPCB	1 m	FX5UC-32MT/D, FX5UC-32MT/DSS
B	Power cable for FX5-C32EX/D and FX5-C32ET/D	FX2NC-100BPCB	1 m	FX5UC-32MT/D
C	Power crossover cable for FX5-C32EX/D and FX5-C32ET/D	FX2NC-10BPCB1	0.1 m	FX5-C32EX/D, FX5-C32ET/D

- Wiring FX5-C32EX/D or FX5-C32ET/D to a subsequent stage

Since the two power connectors on each module of FX5-C32EX/D and FX5-C32ET/D are connected in parallel inside the module, they have no difference and can be either an inlet port or outlet port for supplying the power. Thus, cables can be connected to either of the connectors.

However, since the lower connector is covered with a resin cover at shipment from the factory, use the upper connector preferentially. Remove the resin cover only when crossover wiring to a subsequent module is performed.

(FX5-C32EX/DS and FX5-C32ET/DSS do not have power connectors and the power is supplied from using input connectors. Thus, removing the resin cover is not required.)

Precautions

To perform crossover wiring, supply the power from the preceding module to the subsequent module. The power cannot be supplied from the subsequent module to the preceding module.

Removal of power cables

Hold the part "a" on the connector of the power cable with fingers, and remove the cable in the direction of the arrow.

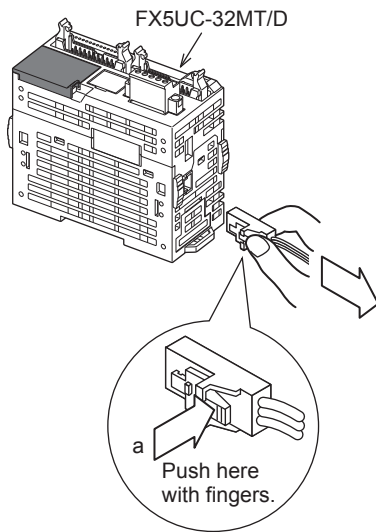

5

Connection of I/O cables

I/O connectors

■ Cable connection to I/O connectors

I/O connectors conform to MIL-C-83503.

For I/O cables, refer to Page 52 Preparation of I/O connectors and prepare them.

- CPU module, I/O modules (extension connector type)

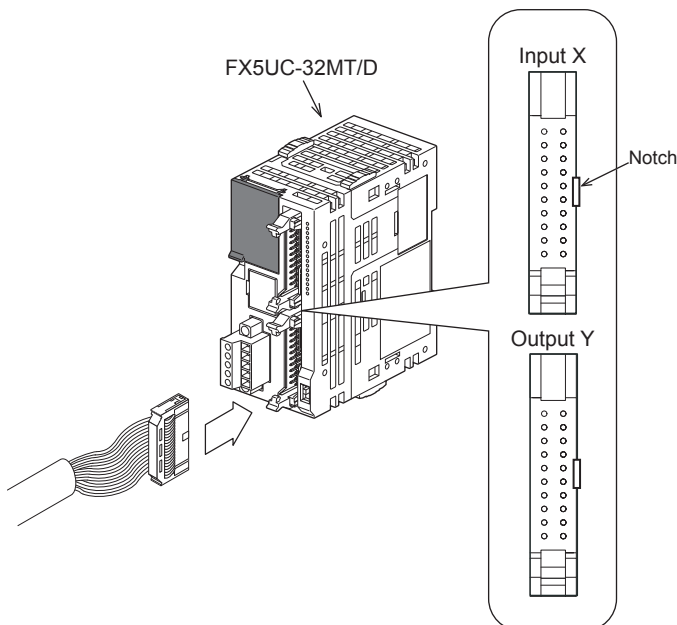

- Terminal module

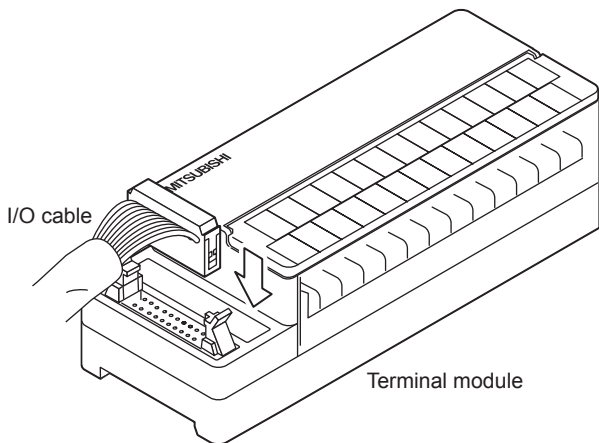

■Preparation of I/O connectors

- Suitable connector (commercial item)

Use 20-pin (1-key) sockets conforming to MIL-C-83503.

Check that the sockets do not interfere with peripheral parts including connector covers in advance.

- I/O cables (Mitsubishi option)

I/O cables on which connectors are attached are prepared.

Model	Length	Description	Type
FX-16E-500CAB-S	5 m	General-purpose I/O cable	<ul style="list-style-type: none"> • Single wire (Wire color: Red) • CPU module side: 20-pin connector is attached.
FX-16E-150CAB	1.5 m	Cables for connection of the terminal module and I/O connectors For the connection with the terminal module, refer to  Page 53 WIRING.	<ul style="list-style-type: none"> • Flat cables (with tube) • On both ends, 20-pin connectors are attached.
FX-16E-300CAB	3 m		
FX-16E-500CAB	5 m		
FX-16E-150CAB-R	1.5 m		<ul style="list-style-type: none"> • Round multicore cables • On both ends, 20-pin connectors are attached.
FX-16E-300CAB-R	3 m		
FX-16E-500CAB-R	5 m		

- Connectors for self-making I/O cables (Mitsubishi option)

Prepare wires and crimp tools by users.

Model and configuration of I/O connectors			Suitable wiring (UL-1061-compliant products are recommended) and tool	
Mitsubishi model		Part description (Manufactured by DDK Ltd.)	Wire size	Crimp tool (Manufactured by DDK Ltd.)
FX2C-I/O-CON for flat cables	10 sets	Crimp connector FRC2-A020-30S	AWG 28 (0.1 mm ²) 1.27-pitch 20 cores	357J-4674D main body 357J-4664N attachment
FX2C-I/O-CON-S for single wires	5 sets	Housing HU-200S2-001 Crimp contact HU-411S	AWG 22 (0.3 mm ²)	357J-5538
FX2C-I/O-CON-SA for single wires	5 sets	Housing HU-200S2-001 Crimp contact HU-411SA	AWG 20 (0.5 mm ²)	357J-13963

Contact for crimp tools: Fujikura Ltd.

- Certified connectors (commercially available connectors)

Connectors made by DDK Ltd. shown above

6 WIRING

6.1 Wiring Preparations

Wiring procedure

Before wiring, make sure that the source power supply is off.

1. Prepare the parts for wiring.

Prepare cables and crimp terminals required for wiring. ( Page 54 Cable Connecting Procedure)

2. Connect the power cable.

Connect the cable to the power connector.

Provide the protection circuit described in this chapter for the power supply circuit. ( Page 57 Power Supply Wiring)

3. Perform class D grounding (grounding resistance: 100 Ω or less) for the ground [] terminal.

Connect the grounded wire to the terminal. ( Page 56 Grounding)

4. Wire input [X] terminal.

Connect sensors and switches to the terminals. ( Page 59 Input Wiring)

5. Wire output [Y] terminal.

Connect the load to terminals.

( Page 68 Output Wiring)

6. Wire the built-in RS-485 communication terminal blocks and Ethernet communication connectors.

 MELSEC iQ-F FX5 User's Manual (Serial Communication)

 MELSEC iQ-F FX5 User's Manual (MODBUS Communication)

 MELSEC iQ-F FX5 User's Manual (Ethernet Communication)

7. Wire intelligent function modules and expansion adapters.

 MELSEC iQ-F FX5 User's Manual (Serial Communication)

 MELSEC iQ-F FX5 User's Manual (MODBUS Communication)

User's manual for each intelligent function module

6.2 Cable Connecting Procedure

The cable connecting procedure is explained below.

European-type terminal block

Wire the European-type terminal block in accordance with the following specifications.

Suitable wiring

	Number of wires connected per terminal	Wire size		Tightening torque
		Solid wires, stranded wire	Wire ferrule with insulation sleeve	
Terminal block for built-in RS-485 communication, Expansion adapter	One wire	0.3 to 0.5 mm ² (AWG22 to 20)	0.3 to 0.5 mm ² (AWG22 to 20)	0.22 to 0.25 N·m
	Two wires	0.3 mm ² (AWG22)	—	

Precautions

Do not tighten terminal screws with torque beyond the specified range. Otherwise it may cause equipment failure or malfunction.

Wire end treatment

Treat stranded and solid wires as they are or use wire ferrules with insulation sleeves for wiring terminals.

■When stranded and solid wires are treated as they are

- Twist the end of stranded wires and make sure that there are no loose wires.
- Do not solder-plate the electric wire ends.

Stripping dimensions of electric wire ends

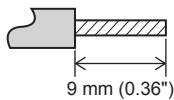

■When wire ferrules with insulation sleeves are used

Depending on the thickness of a wiring sheath used, it may be difficult to insert the sheath into an insulating sleeve. Refer to the external dimensions as a reference to select wires.

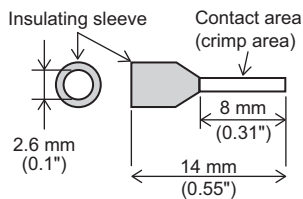

<Reference>

	Manufacturer	Model	Crimp tool
Terminal block for built-in RS-485 communication, Expansion adapter	Phoenix Contact GmbH & Co. KG	AI 0.5-8 WH	CRIMPFOX 6 CRIMPFOX 6T-F

■Tool

For tightening terminals, use a small, commercially-available screwdriver with a straight tip. The recommended shape is shown in the figure on the right.

■Precautions

When a precision screwdriver with a small grip is used, the specified tightening torque cannot be obtained. Use the following screwdriver or equivalent product (grip diameter: 25 mm (0.99")) to obtain the tightening torque specified above.

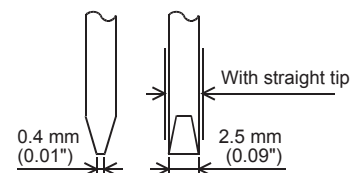

<Reference>

Manufacturer	Model
Phoenix Contact GmbH & Co. KG	SZS 0.4 × 2.5

Screw terminal block

Wire the screw terminal block in accordance with the following specifications.

For information concerning screw terminal blocks for intelligent function modules, refer to User's manual for each intelligent function module.

Terminal block screw size and tightening torque

Model	Terminal screw size	Tightening torque
I/O module (extension cable type)	M3	0.5 to 0.8 N·m
Terminal module	M3.5	
Intelligent function module	Refer to User's manual for each product.	

Precautions

Do not tighten terminal screws exceeding the specified torque range. Otherwise it may cause equipment failure or malfunction.

Wire end treatment

Crimp terminal size differs depending on terminal screw size and wiring methods used.

- Use crimp terminals of the following sizes.

■ M3 terminal screw

- When a single wire is connected to a single terminal

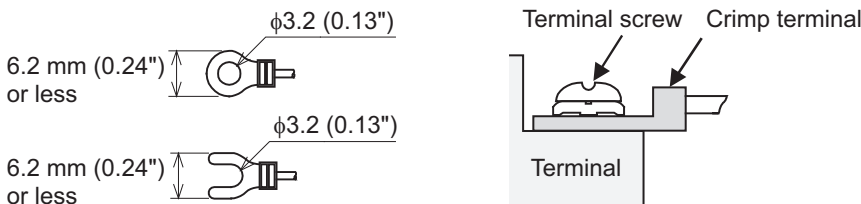

<Reference>

Manufacturer	Model	Supported standard	Crimp tool
JST Mfg. Co., Ltd.	FV1.25-B3A	UL Listed	YA-1 (JST Mfg. Co., Ltd.)
	FV2-MS3		

- When two wires are connected to a single terminal

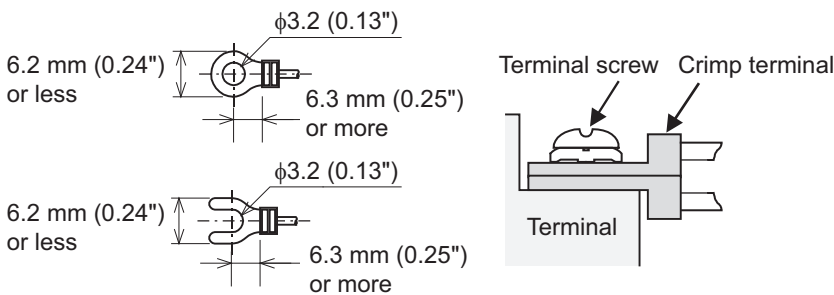

<Reference>

Manufacturer	Model	Supported standard	Crimp tool
JST Mfg. Co., Ltd.	FV1.25-B3A	UL Listed	YA-1 (JST Mfg. Co., Ltd.)

■M3.5 terminal screw

- When a single wire is connected to a single terminal

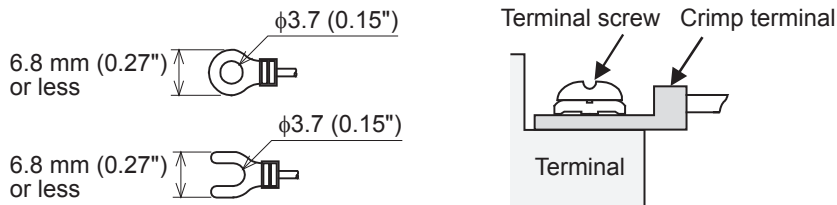

- When two wires are connected to a single terminal

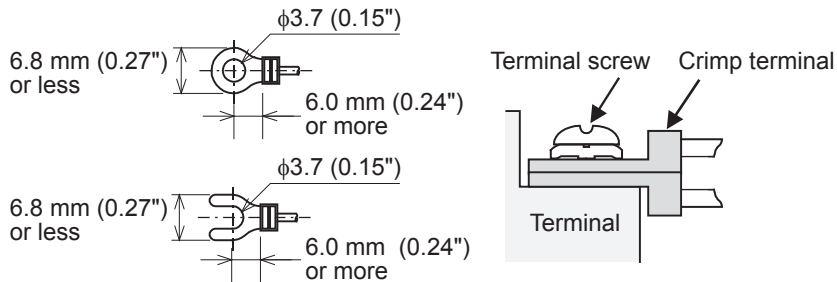

6.3 Grounding

Perform the following.

- Perform class D grounding (Grounding resistance: 100 Ω or less).
- Ground the PLC independently when possible.
- If the PLC cannot be grounded independently, perform the "Common grounding" shown below.

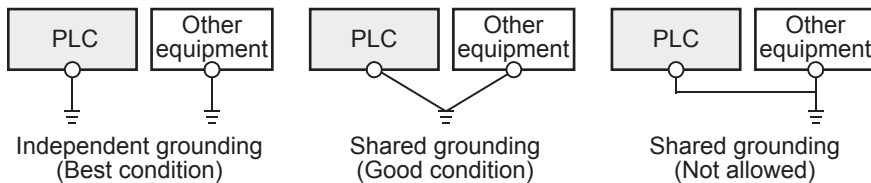

PLC extension devices (excluding communication adapters)

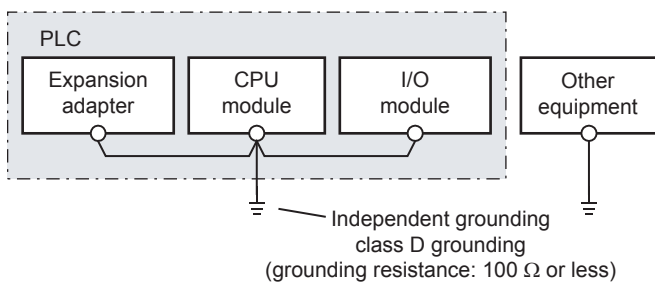

- Locate the ground point as close to the PLC as possible to minimize the length of the grounding wire.

6.4 Power Supply Wiring

Examples of DC power supply wiring

Provide a 24 V DC power supply to FX5UC CPU module and other modules. Use dedicated connectors to provide the power supply. (Refer to  Page 50 Connection of power cables.)

Power supply wiring example of FX5UC-32MT/D

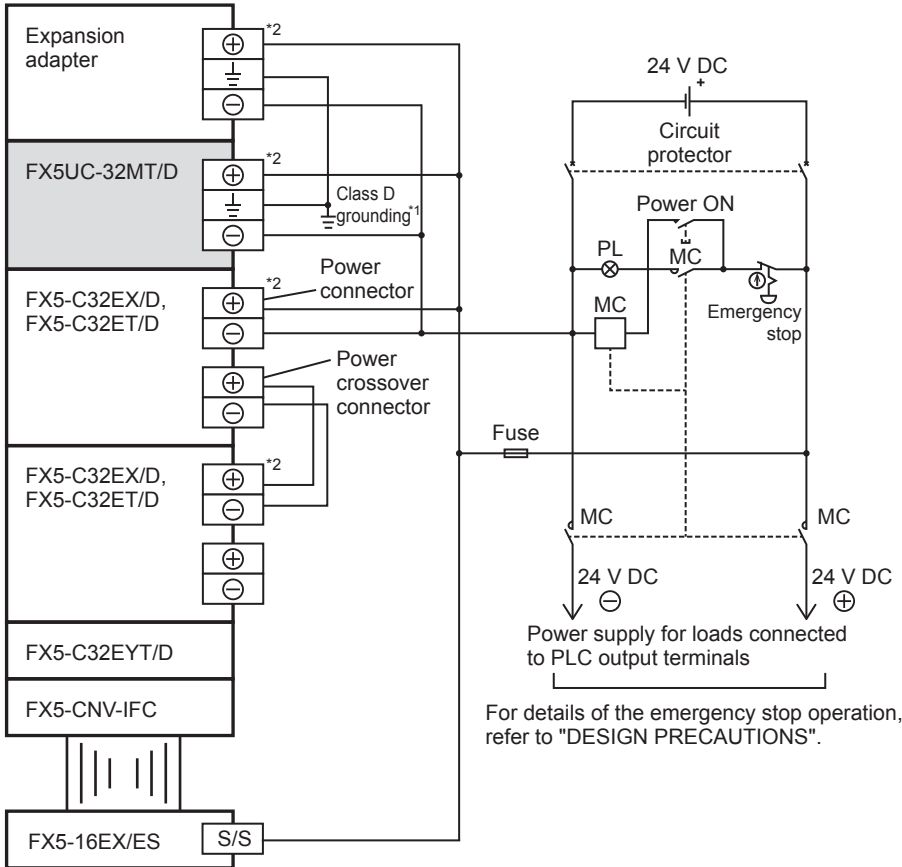

*1 The grounding resistance should be 100 Ω or less.

*2 Using the same power supply to each module and extension adapters is recommended. When a different power supply is used to them, turn on the power supply at the same time with the CPU module or earlier than the CPU module. When tuning off the power, confirm the safety of the system and turn off the CPU module at the same time. Some extension modules may not have power supply terminals.

Power supply wiring example of FX5UC-32MT/DSS

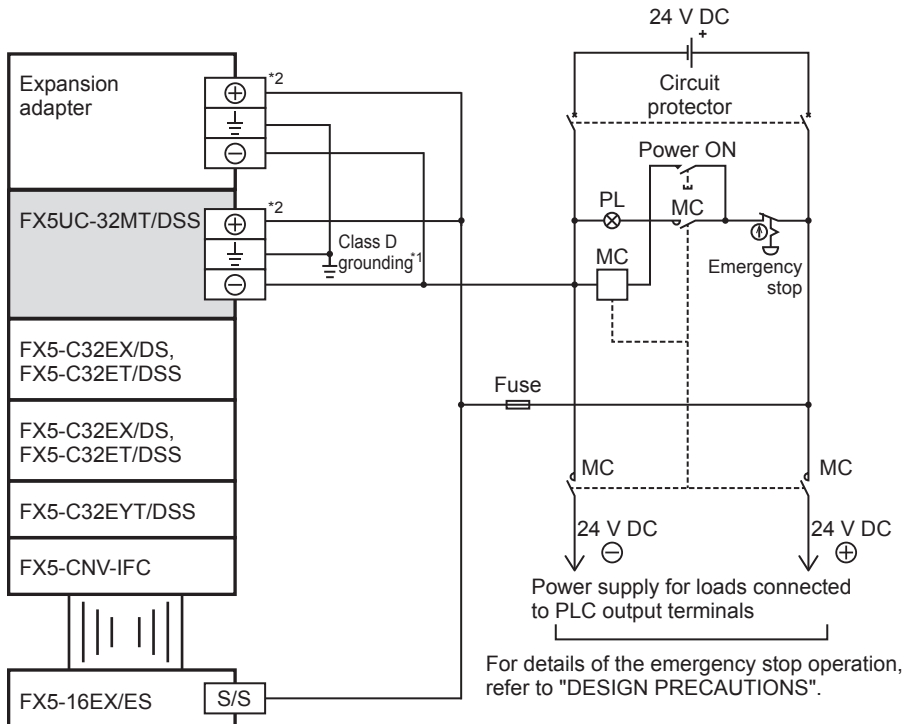

*1 The grounding resistance should be 100 Ω or less.

*2 Using the same power supply to each module and extension adapters is recommended. When a different power supply is used to them, turn on the power supply at the same time with the CPU module or earlier than the CPU module. When tuning off the power, confirm the safety of the system and turn off the CPU module at the same time. Some extension modules may not have power supply terminals.

6.5 Input Wiring

The input wiring of the CPU modules, I/O modules, and terminal modules is explained below.

24 V DC input

For input specifications of the CPU modules, refer to [Page 18 Input Specifications](#).

For input specifications of the I/O modules, refer to [Page 115 Input specifications](#).

For input specifications of the terminal modules, refer to [Page 126 Input specifications](#).

Sink and source input

■ Differences between the sink input circuit and the source input circuit

- Sink input [-common]

Sink input means a DC input signal with a current flowing from the input (X) terminal. When a device such as a transistor output type sensor is connected, NPN open collector transistor output can be used.

Circuit example for FX5UC-32MT/D

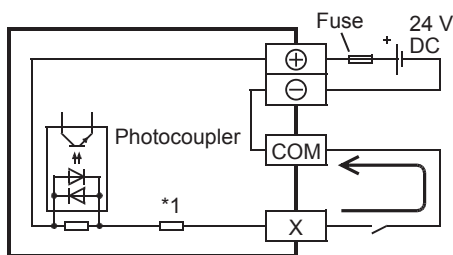

Circuit example for FX5UC-32MT/DSS

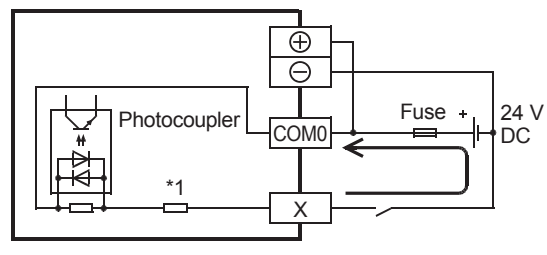

- Source input [+common]

Source input means a DC input signal with a current flowing into the input (X) terminal. When a device such as a transistor output type sensor is connected, the PNP open collector transistor output can be used.

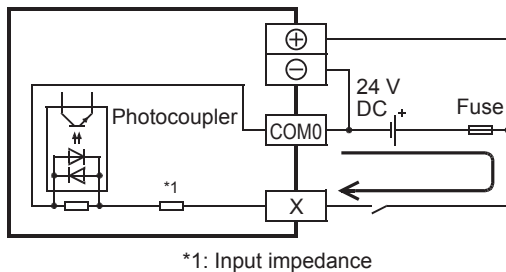

■ Switching between sink/source inputs

Sink and source inputs for FX5UC-32MT/DSS are switched by changing connection methods; the connection in which the current flows from the input (X) terminal or the connection in which the current flows into the input (X) terminal.

- Sink input: The connection in which the current flows from the input (X) terminal ([Page 64 Sink input wiring](#))
- Source input: The connection in which the current flows into the input (X) terminal ([Page 65 Source input wiring](#))

Point

Inputs (X) of FX5UC-32MT/DSS can be set to either sink input or source input. However, sink and source input modes cannot be mixed.

Handling of 24 V DC input

Input terminal

FX5UC-32MT/D

When a no-voltage contact or NPN open collector transistor output is connected between an input (X) terminal and the [COM] terminal and the circuit is closed, the input (X) turns on.

To turn on the I/O display LEDs, set the DISP switch to IN.

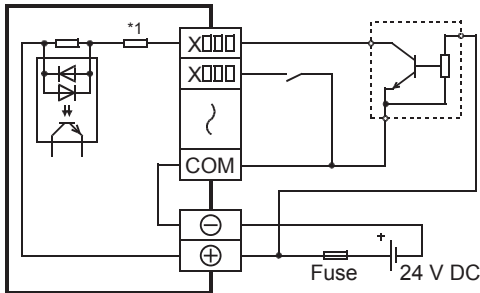

*1: Input impedance

FX5UC-32MT/DSS

In the sink input, the input (X) is turned on by connecting 24 V DC [+] with the [COM] terminal, and connecting a no-voltage contact or NPN open collector transistor output between the input terminal and 24 V DC to close the circuit.

To turn on the I/O display LEDs, set the DISP switch to IN.

Sink input wiring

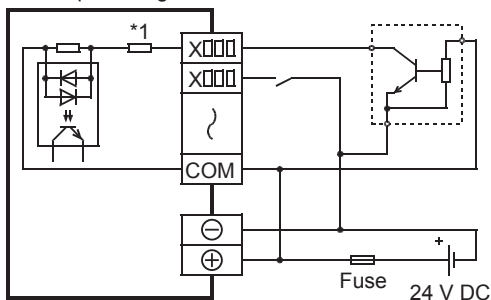

*1: Input impedance

In the source input, the input (X) is turned on by connecting 24 V DC [-] with the [COM] terminal, and connecting a no-voltage contact or PNP open collector transistor output between the input terminal and 24 V DC to close the circuit.

To turn on the I/O display LEDs, set the DISP switch to IN.

Source input wiring

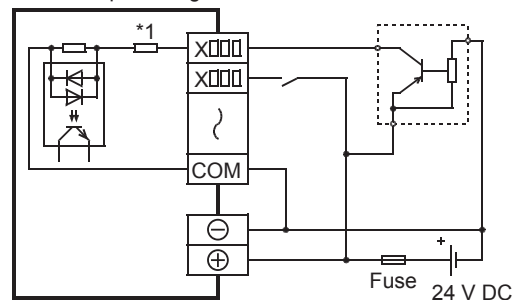

*1: Input impedance

RUN terminal setting

X000 to X017 of a CPU module can be used as RUN input terminals by setting parameters.

MELSEC iQ-F FX5 User's Manual (Application)

Input circuit

Function of an input circuit

The primary and secondary circuits for input are insulated with photocoupler, and the second circuit is provided with a C-R filter.

The C-R filter is designed to prevent malfunctions caused by chattering of the input contact and noise from input line.

Input has a response delay switching from ON to OFF and OFF to ON, shown in the following table.

Item	Specifications		
Input response time (H/W filter delay)	FX5UC-32MT/D, FX5UC-32MT/DSS	X000 to X005	ON: 2.5 μ s or less OFF: 2.5 μ s or less
		X006 to X017	ON: 30 μ s or less OFF: 50 μ s or less
	I/O module	ON: 50 μ s or less OFF: 150 μ s or less	

Change of filter time

All input circuits have digital filters, and the input response time shown in the following table can be added by setting parameters. When using this product in an environment with much noise, set the digital filter.

Item	Specifications
Input response time (Digital filter setting value)	None, 10 μ s, 50 μ s, 0.1 ms, 0.2 ms, 0.4 ms, 0.6 ms, 1 ms, 5 ms, 10 ms (initial values), 20 ms, 70 ms

Input sensitivity

For the input signal current and input sensitivity current of the CPU modules, refer to [Page 18 Input Specifications](#).
 For the input signal current and input sensitivity current of the I/O modules, refer to [Page 115 Input specifications](#).

Display of operation

With the DISP switch set to IN, the LED turns on when photocouplers are actuated.

Precautions for connecting input devices

In the case of no-voltage contact

Use input devices appropriate for low electric current.
 If no-voltage contacts for high current (switches) are used, contact failure may occur.

In the case of input device with built-in series diode

The voltage drop of the series diode should be the following value or less.
 Also make sure that the input current is over the input-sensing level while the switches are on.

Item	Specifications		
Voltage drop	FX5UC-32MT/D, FX5UC-32MT/DSS	X000 to X005	3.9 V
		X006 to X017	4.1 V
	I/O module		2.4 V

In the case of input device with built-in parallel resistance

Use a device with a parallel resistance Rp (kΩ) of the following value or more.

Item	Specifications		
Parallel resistance Rp (kΩ)	FX5UC-32MT/D, FX5UC-32MT/DSS	X000 to X005	14
		X006 to X017	15
	I/O module		13

If the resistance is less than the above parallel resistance Rp (kΩ), connect a bleeder resistance Rb (kΩ) obtained by the following formula as shown in the following figure.

Item	Specifications		
Bleeder resistance Rb (kΩ)	FX5UC-32MT/D, FX5UC-32MT/DSS	X000 to X005	$5R_p / (14 - R_p)$ or less
		X006 to X017	$4R_p / (15 - R_p)$ or less
	I/O module		$6R_p / (13 - R_p)$ or less

- Wiring example of FX5UC-32MT/D

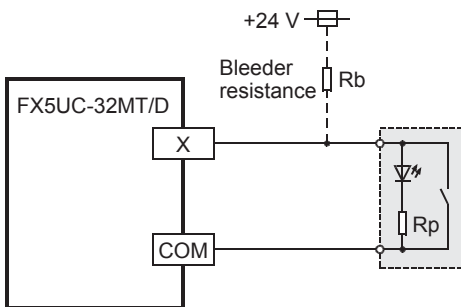

- Wiring example of FX5UC-32MT/DSS

- Sink input wiring

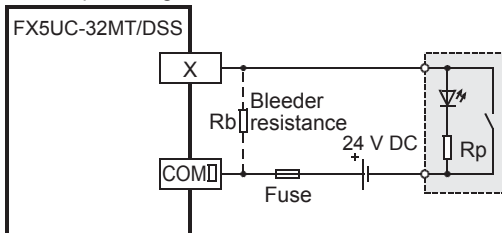

- Source input wiring

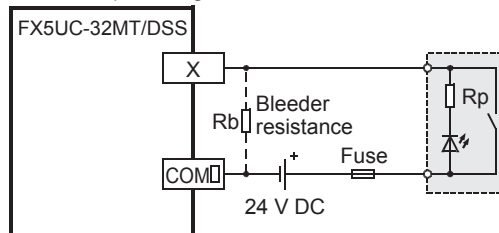

■ In the case of 2-wire proximity switch

Use a two-wire proximity switch whose leakage current, I_l is 1.5 mA or less when the switch is off.

If the resistance is larger than leakage current, I_l of 1.5 mA, connect a bleeder resistance R_b ($k\Omega$), obtained by the following formula as shown in the following figure.

Item			Specifications
Bleeder resistance R_b ($k\Omega$)	FX5UC-32MT/D,	X000 to X005	$7 / (I_l - 1.5)$ or less
	FX5UC-32MT/DSS	X006 to X017	$7 / (I_l - 1.5)$ or less
	I/O module		$9 / (I_l - 1.5)$ or less

- Wiring example of FX5UC-32MT/D

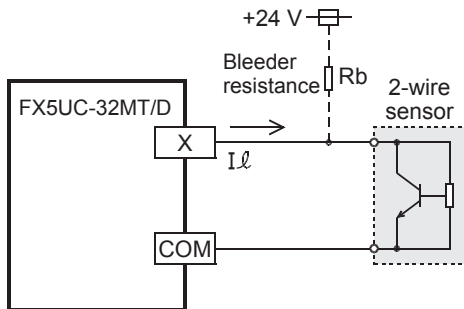

- Wiring example of FX5UC-32MT/DSS

- Sink input wiring

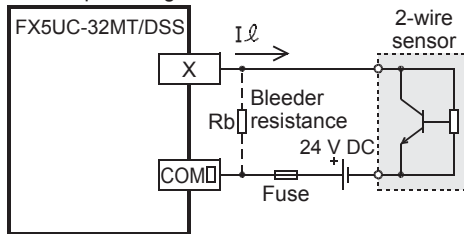

- Source input wiring

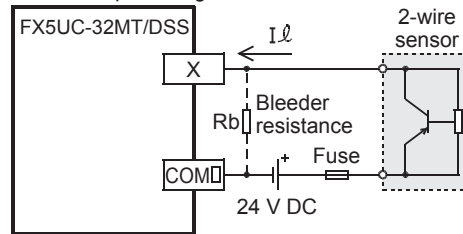

When a high-speed pulse is captured

When capturing pulses of a response frequency of 50 to 200 kHz on using the input X000 to X005, wire the terminals as stated below.

- The wire length should be 5 m (16.4") or less.
- Use shielded twisted-pair cables for connecting cables. Ground the shield of each shielded cable only on the CPU module side.
- Connect a 1.5 $k\Omega$ (1 W or more) bleeder resistance to the input terminal, so that the sum of the load current of the open collector transistor output on the mating device and the input current of the CPU module is 20 mA or more.

The above-mentioned restrictions are due to specifications of connecting device (encoder etc.). Please adjust the cable length and load, for connecting device.

Input wiring example

When a sink-input-dedicated CPU module is used

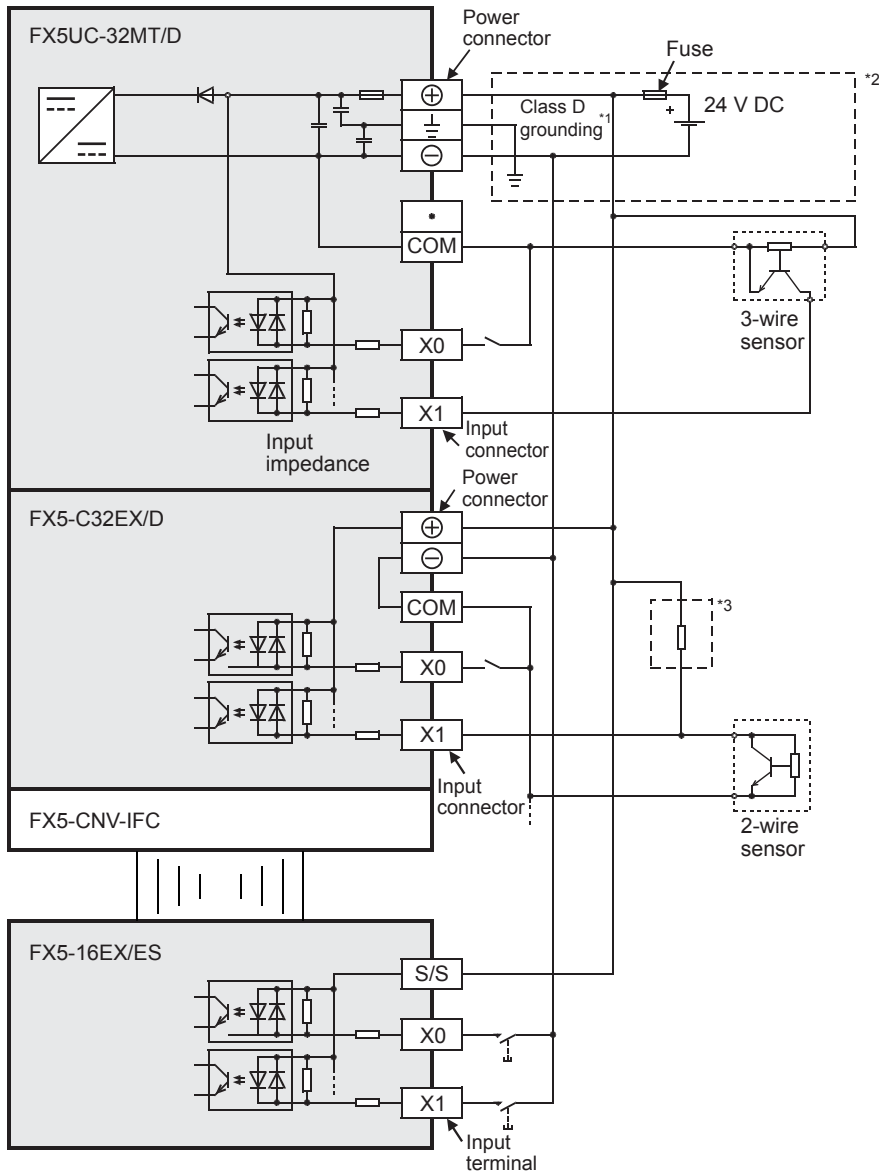

*1 The grounding resistance should be 100 Ω or less.

*2 Handle the power supply circuit properly in accordance with "Power Supply Wiring".

*3 For an input device having a parallel resistance or a two-wire proximity switch, a bleeder resistance may be required.

When a CPU module common to sink and source inputs is used

■ Sink input wiring

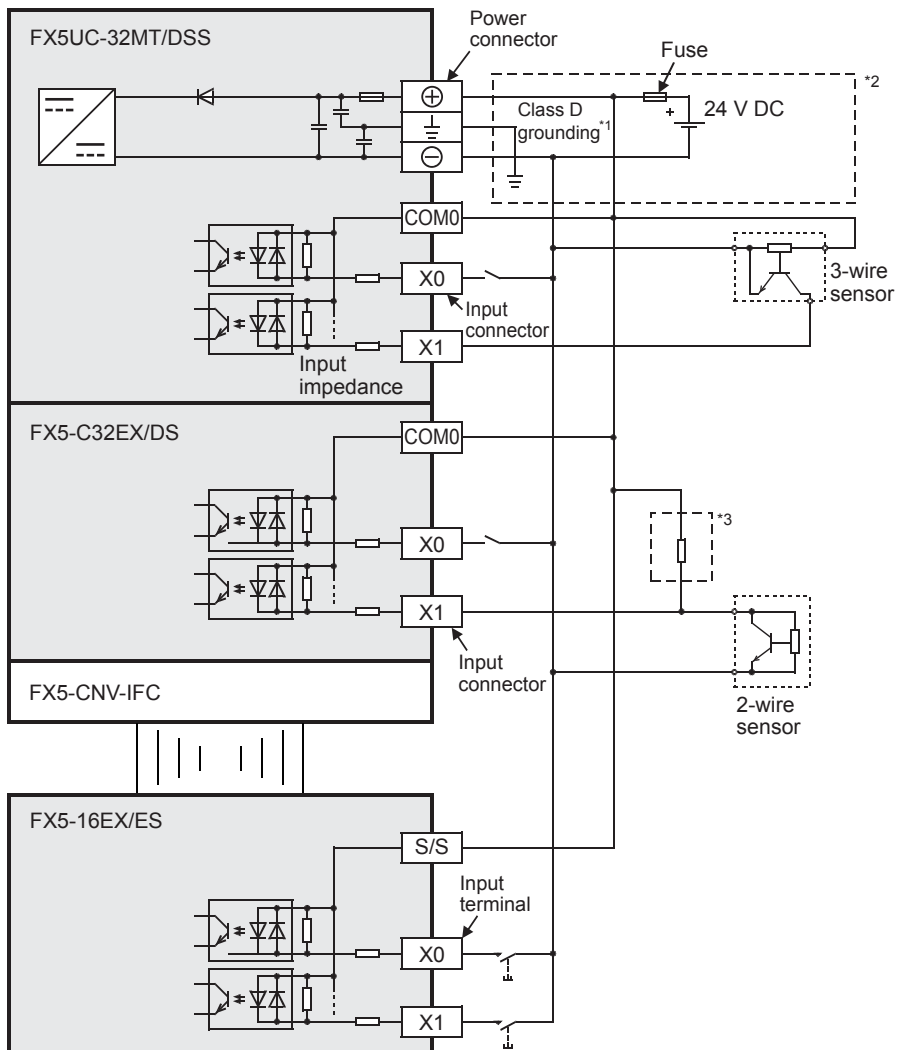

*1 The grounding resistance should be 100 Ω or less.

*2 Handle the power supply circuit properly in accordance with "Power Supply Wiring".

*3 For an input device having a parallel resistance or a two-wire proximity switch, a bleeder resistance may be required.

Source input wiring

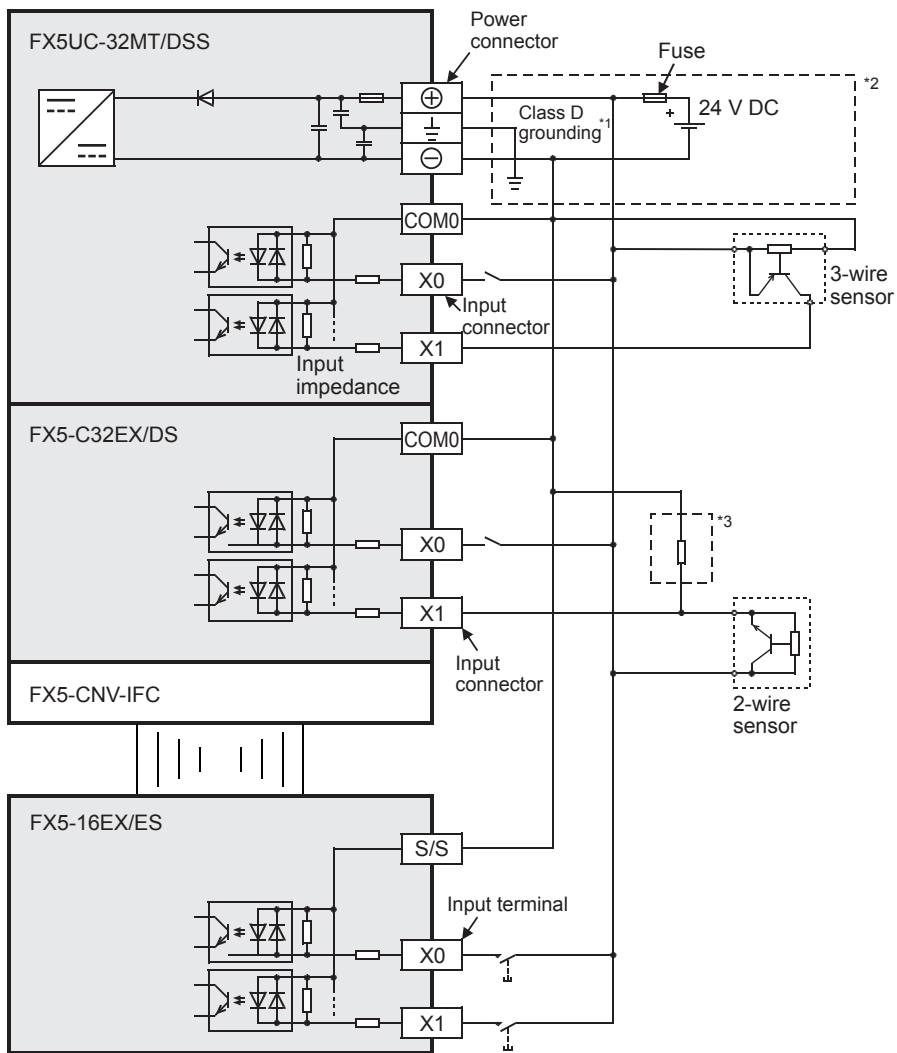

*1 The grounding resistance should be 100 Ω or less.

*2 Handle the power supply circuit properly in accordance with "Power Supply Wiring".

*3 For an input device having a parallel resistance or a two-wire proximity switch, a bleeder resistance may be required.

Input wiring examples of terminal modules

FX-16E-TB, FX-32E-TB

Connected models: FX5UC-32MT/D, FX5-C32EX/D, FX5-C32ET/D

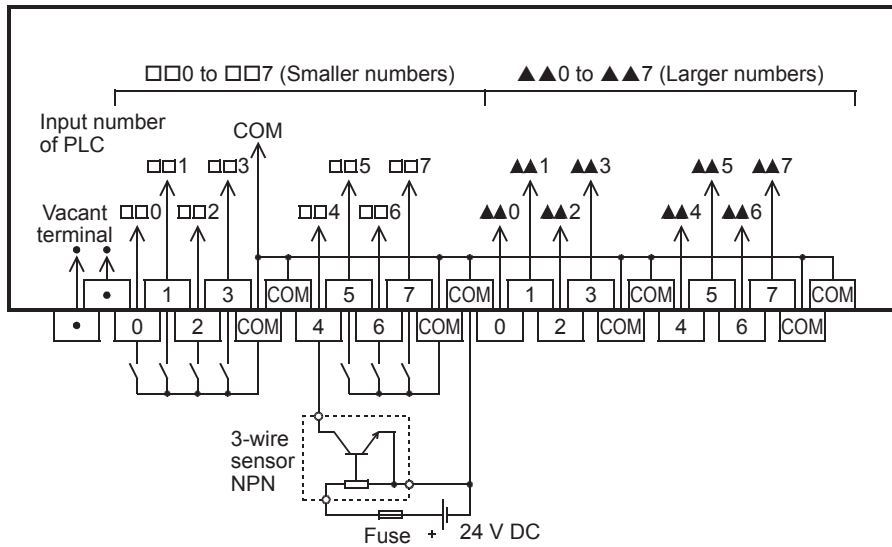

FX-16E-TB/UL, FX-32E-TB/UL

Connected models: FX5UC-32MT/DSS, FX5-C32EX/DS, FX5-C32ET/DSS

- In the case of sink wiring

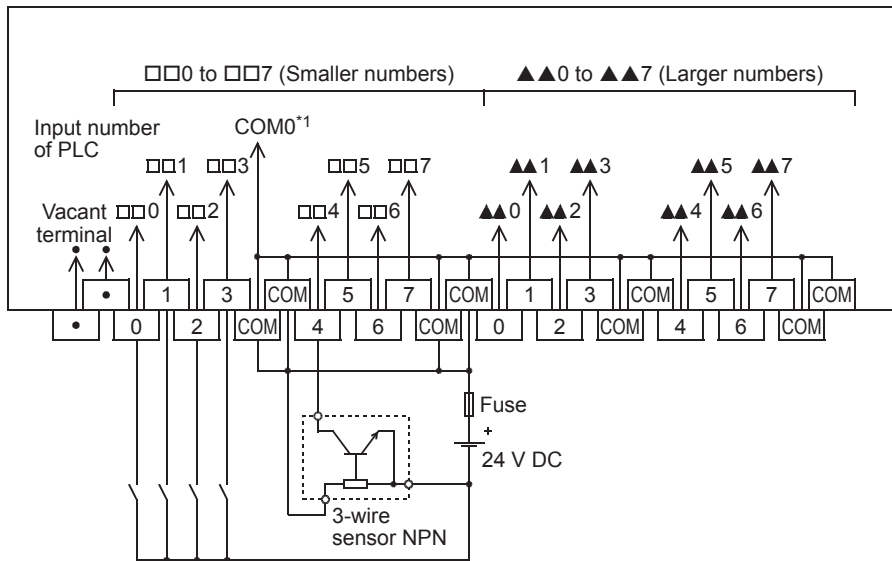

*1 Replace this number with the one of the connected connector.

- In the case of source wiring

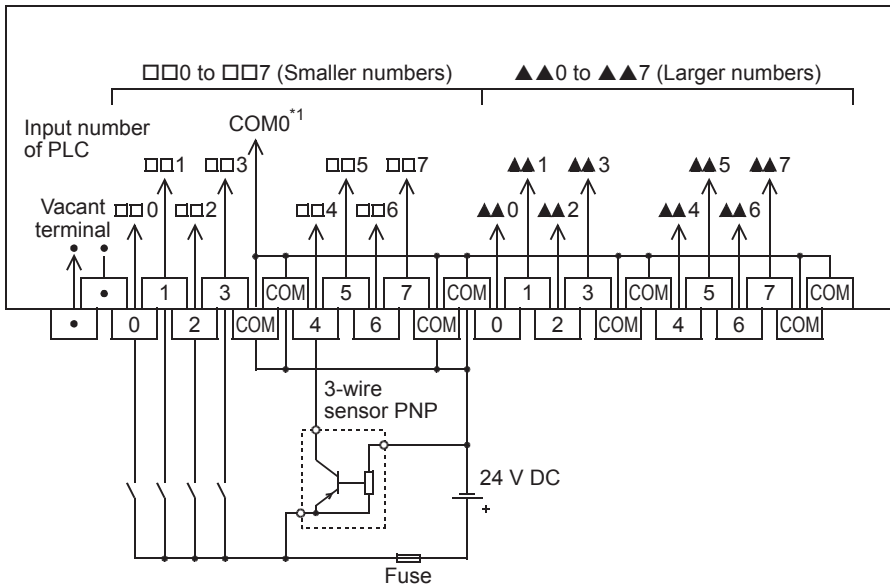

*1 Replace this number with the one of the connected connector.

FX-16EX-A1-TB

Connected models: FX5UC-32MT/D, FX5-C32EX/D, FX5-C32ET/D

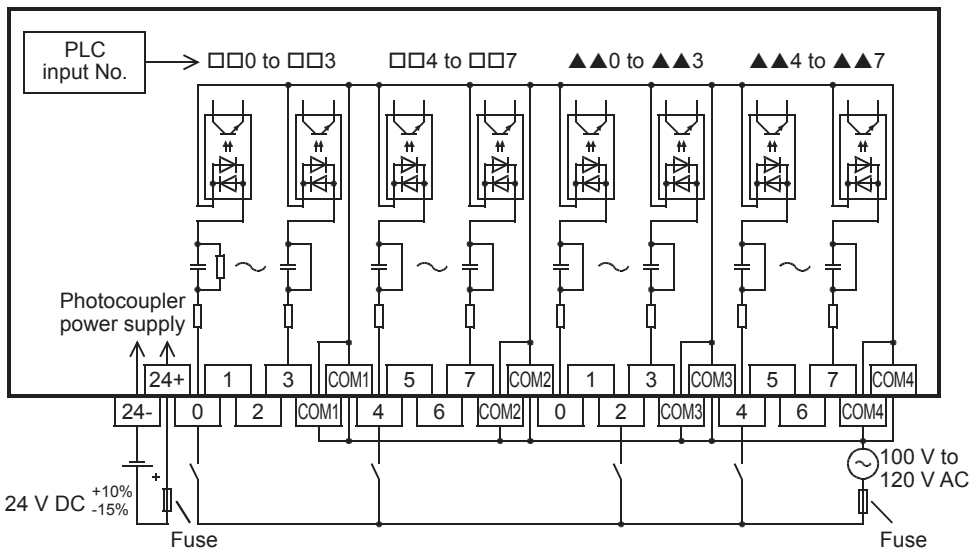

6.6 Output Wiring

The output wiring of the CPU modules, I/O modules, and terminal modules is explained below.

Transistor output

For output specifications of the CPU modules, refer to [Page 20 Output Specifications](#).

For output specifications of the I/O modules, refer to [Page 116 Output specifications](#).

For output specifications of the terminal modules, refer to [Page 127 Output specifications](#).

Sink and source output

Sink output and source output products are available for transistor outputs of the CPU module, I/O modules, and terminal modules.

Differences in circuit

- Sink output [-common]

Output to make load current flow into the output (Y) terminal is called sink output.

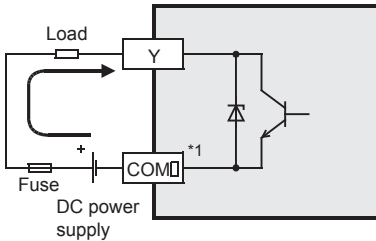

*1 The number "0" or "1" is applied in □.

- Source output [+common]

Output to make load current flow out of the output (Y) terminal is called source output.

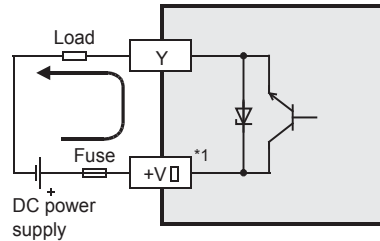

Handling of transistor output

Output terminal

8 transistor output points are covered by one common terminal.

- Sink output

The COM□ (number) terminals that are connected each other inside the PLC are prepared. For external wiring, connect the COM□ (number) terminals outside the PLC to reduce the load per one COM□ terminal.

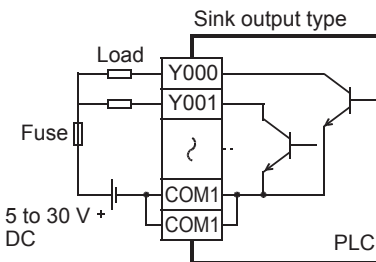

- Source output

The +V□ (number) terminals that are connected each other inside the PLC are prepared. For external wiring, connect the +V□ (number) terminals outside the PLC to reduce the load per one +V□ terminal.

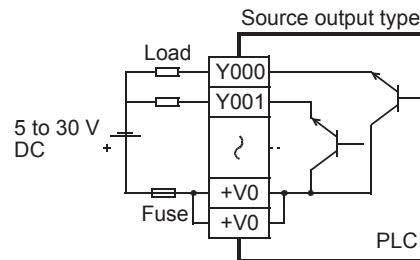

External power supply

For driving the load, use a smoothing power supply of 5 to 30 V DC that can output a current two or more times the current rating of the fuse connected to the load circuit.

Insulation of circuit

The internal circuit of the PLC and the output transistor are insulated with a photocoupler.

The common blocks are separated from one another.

Display of operation

With the DISP switch set to OUT, the LED turns on and the output transistor turns on when photocouplers are actuated.

■Response time

Time taken from when the photocoupler of the module is driven (or shut off) to when the transistor is turned on (or off) differs depending on the output terminal used. For specifications of each module, refer to the following.

For output specifications of the CPU modules, refer to [Page 20 Output Specifications](#).

For output specifications of the I/O modules, refer to [Page 116 Output specifications](#).

For output specifications of the terminal modules, refer to [Page 127 Output specifications](#).

Point

The transistor OFF time is longer under lighter loads. For example, under a load of 24 V DC 40 mA, the response time is approx. 0.3 ms.

When response performance is required under light loads, provide a dummy resistor as shown below to increase the load current.

• Sink output type

• Source output type

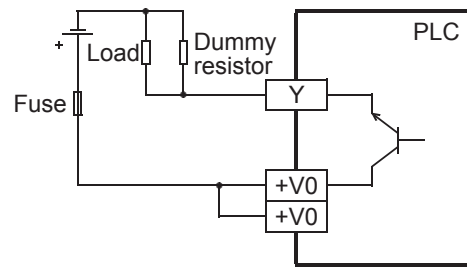
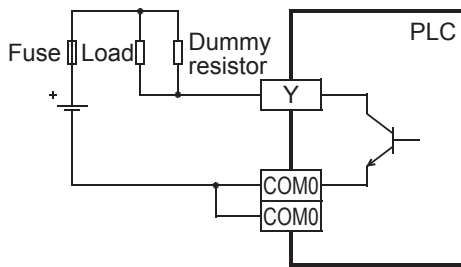

■Output current

Maximum load differs for each module. For specifications of each module, refer to the following.

For output specifications of the CPU modules, refer to [Page 20 Output Specifications](#).

For output specifications of the I/O modules, refer to [Page 116 Output specifications](#).

For output specifications of the terminal modules, refer to [Page 127 Output specifications](#).

When driving a semiconductor element, carefully check the input voltage characteristics of the applied element.

■Open circuit leakage current

0.1 mA or less.

Wiring precautions

■Protection circuit for load short-circuiting

A short-circuit at a load connected to an output terminal could cause burnout at the output device or the PCB. To prevent this, a protection fuse should be inserted at the output. Use a load power supply capacity that is at least 2 times larger than the load current.

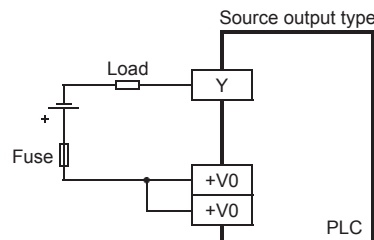
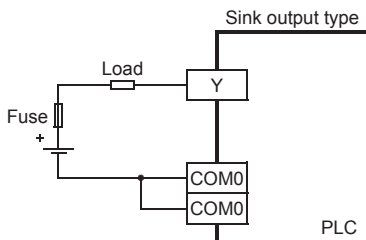

■ Contact protection circuit for inductive loads

When an inductive load is connected, connect a diode (for commutation) in parallel with the load as necessary. The diode (for commutation) must comply with the following specifications.

Standard	
Reverse voltage	5 to 10 times the load voltage
Forward current	Load current or more

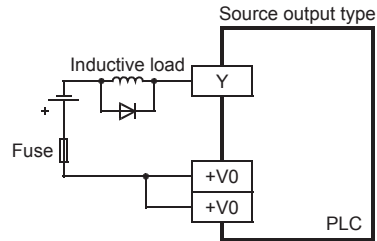
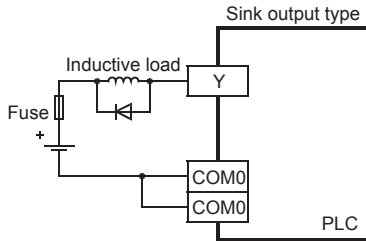

■ Interlock

For loads such as forward/reverse contactors, etc., where a hazardous condition could result if switched ON simultaneously, an external interlock should be provided for interlocking along with an interlock in the PLC program as shown below.

Sink output type

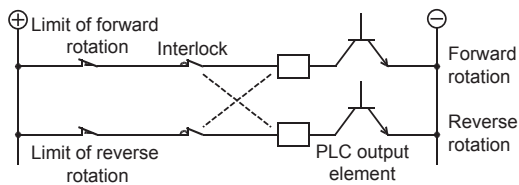

Source output type

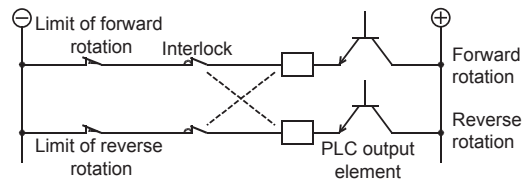

Relay output

For output specifications of the I/O modules, refer to [☞ Page 116 Output specifications](#).

For output specifications of the terminal modules, refer to [☞ Page 127 Output specifications](#).

Product life of relay output contacts

The product life of relay contacts varies considerably depending on the load type used.

Note that loads generating reverse electromotive force or rush current may cause poor contact or welding of contacts which may lead to considerable reduction of the contact product life.

■Inductive load

Inductive loads generate large reverse electromotive force between contacts at shutdown, which may cause arc discharge. At a fixed current consumption, as the power factor (phase between current and voltage) gets smaller, the arc energy gets larger. The following table shows the standard life of contacts used for inductive loads, such as contactors and solenoid valves.

Model	Inductive load	Standard life
FX5-□EYR/ES	20 VA	500,000 times
Terminal module	35 VA	

The following table shows the approximate life of a relay based on the results of our operation life test.

- Test condition: 1 sec. ON/1 sec. OFF

Load capacity		Contact life
■FX5-□EYR/ES		
20 VA	0.2 A/100 V AC	3,000,000 times
	0.1 A/200 V AC	
35 VA	0.35 A/100 V AC	1,000,000 times
	0.17 A/200 V AC	
80 VA	0.8 A/100 V AC	200,000 times
	0.4 A/200 V AC	
■Terminal module		
35 VA	0.35 A/100 V AC	3,000,000 times
	0.17 A/200 V AC	
80 VA	0.8 A/100 V AC	1,000,000 times
	0.4 A/200 V AC	
120 VA	1.2 A/100 V AC	200,000 times
	0.6 A/200 V AC	

The product life of relay contacts becomes considerably shorter than the above conditions when the rush overcurrent is shut down.

Please refer to the following measures regarding the inductive load.

[☞ Page 73 Contact protection circuit for inductive loads](#)

Some types of inductive loads generate rush current 5 to 15 times the stationary current at activation. Make sure that the rush current does not exceed the current corresponding to the maximum specified resistance load.

■Lamp load

Lamp loads generally generate rush current 10 to 15 times the stationary current. Make sure that the rush current does not exceed the current corresponding to the maximum specified resistance load.

■Capacitive load

Capacitive loads can generate rush current 20 to 40 times the stationary current. Make sure that the rush current does not exceed the current corresponding to the maximum specified resistance load.

Capacitive loads such as capacitors may be present in electronic circuit loads including inverters.

■Resistance load

For maximum load specifications of resistance load, refer to the following.

For output specifications of the I/O modules, refer to [☞ Page 116 Output specifications](#).

For output specifications of the terminal modules, refer to [☞ Page 127 Output specifications](#).

Handling of relay output

■Output terminal

One common terminal is used for 4 or 8 relay output points.

The common terminal blocks can drive loads of different circuit voltage systems (for example: 100 V AC and 24 V DC).

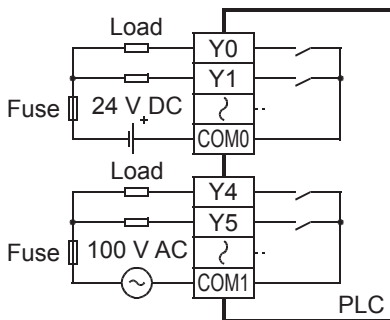

■External power supply

Use an external power supply of 30 V DC or less or 240 V AC or less (250 V AC or less when the module does not comply with CE, UL, or cUL standards) for loads.

■Insulation of circuit

The PLC internal circuit and external load circuits are electrically insulated between the output relay coil and contact.

The common terminal blocks are separated from one another.

■Display of operation

When power is applied to the output relay coil, the LED is lit, and the output contact is turned on.

■Response time

The response time of the output relay from when the power is applied to the coil until the output contact is turned on, and from when the coil is shut off until the output contact is turned off is approx. 10 ms.

■Output current

At a circuit voltage of 240 V AC or less (250 V AC or less when the module does not comply with CE, UL, or cUL standards), a resistance load of 2 A per point or an inductive load of 80 VA or less (100 V AC or 200 V AC) can be driven.

For the life of the contact for switching an inductive load, refer to [Page 71 Inductive load](#).

When an inductive load is switched, connect a diode (for commutation) or a surge absorber in parallel with this load.

DC circuit	AC circuit
Diode (for commutation)	Surge absorber

■Open circuit leakage current

There is no leakage current when the output are OFF.

Wiring precautions

■ Protection circuit for load short-circuiting

A short-circuit at a load connected to an output terminal could cause burnout at the output element or the PCB. To prevent this, a protection fuse should be inserted at the output.

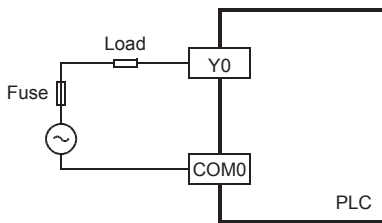

■ Contact protection circuit for inductive loads

An internal protection circuit for the relays is not provided for the relay output circuit in this product. It is recommended to use inductive loads with built-in protection circuits. When using loads without built-in protection circuits, insert an external contact protection circuit, etc. to reduce noise and extend the product life.

• DC circuit

Connect a diode in parallel with the load. The diode (for commutation) must comply with the following specifications.

(Standard)

Reverse voltage: 5 to 10 times as high as the load voltage

Forward current: Load current or more

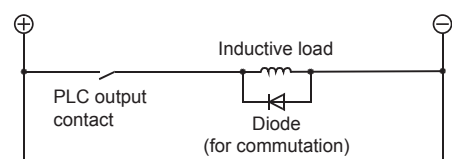

• AC circuit

Connect a surge absorber (CR composite parts such as surge killers, spark killers, etc.) parallel to the load. Select a surge absorber with voltage rating that is suitable for the output used. For other specifications, refer to the following.

(Standard)

Electrostatic capacity: Approx. 0.1 μF

Resistance: Approx. 100 to 200 Ω

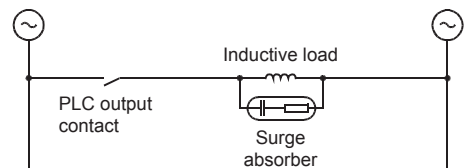

■ Interlock

For loads such as forward/reverse contactors, etc., where a hazardous condition could result if switched ON simultaneously, an external interlock should be provided for interlocking along with an interlock in the PLC program, as shown below.

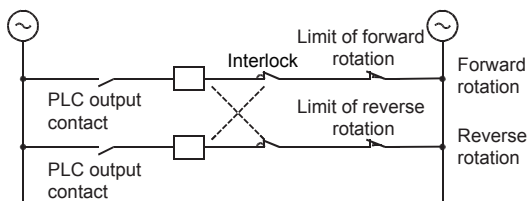

■ In-phase

PLC output contacts (*) should be used in an "in-phase" manner.

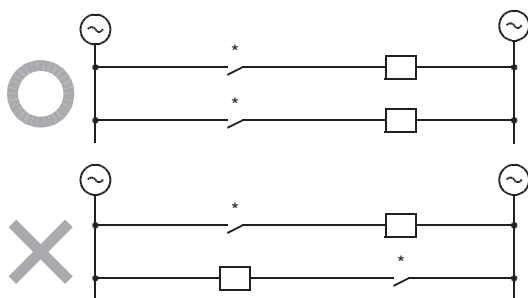

Triac output

For output specifications of the terminal modules, refer to [Page 127 Output specifications](#).

Handling of triac output

Output terminal

Four triac output points are covered by one common terminal. The common terminal blocks can drive loads of different circuit voltage systems (Example: 100 V AC and 24 V DC).

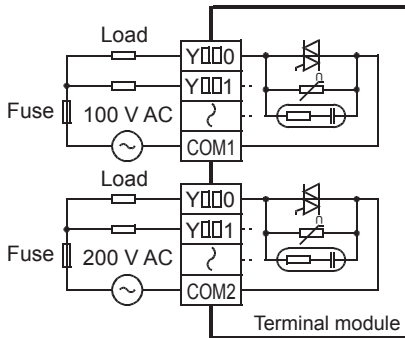

Insulation of circuit

The internal circuit and the output element (triac) are insulated with photothyristors. The common blocks are separated from one another.

Display of operation

The LED turns on and the output triac is turned on when photothyristors are actuated.

Response time

The response time until the output triac is turned on after the photothyristors are actuated (or shut off) is 1 ms or less, and the response time until the output triac is turned off is 10 ms or less.

Output current

Current of 0.3 A can flow per one output point. However, current of four output points should be 0.8 A (average of 0.2 A per one point) to suppress temperature rise. When a load with a high rush current is frequently turned on or off, the mean-square current should be 0.2 A or less.

<Example>

$$\sqrt{\frac{4^2 \times 0.02 + 0.4^2 \times 0.7}{0.02 + 0.7 + 10}} = 0.2 \text{ A}$$

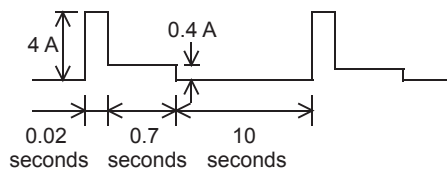

Open circuit leakage current

C-R absorbers are connected in parallel at the triac output terminal for turning off the triac. Thus, open circuit leakage currents of 1 mA/100 V AC or 2 mA/200 V AC occurs. Since the triac output type has open circuit leakage currents, even after the triac output is turned off, a small relay and a minute current load with low rated operation currents may continuously operate.

Therefore, the load should be equal to or more than 0.4 VA/100 V AC or 1.6 VA/200 V AC. For loads lower than these values, connect the surge absorbers described later in parallel.

Wiring precautions

■Protection circuit for load short-circuiting

A short-circuit at a load connected to an output terminal could cause burnout at the output element or the PCB. To prevent this, a protection fuse should be inserted at the output.

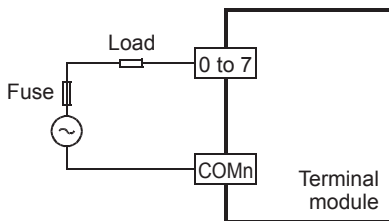

■Minute current load

C-R absorbers are connected in parallel at the triac output circuit for turning off the triac. When a minute current load of 0.4 VA or less/100 V AC or 1.6 VA or less/200 V AC is connected, a surge absorber must be connected in parallel with the load. Select a surge absorber with the rated voltage that is suitable for the output used. For other specifications, refer to the following.

Standard
Electrostatic capacity: Approx. 0.1 μ F
Resistance: Approx. 100 to 200 Ω

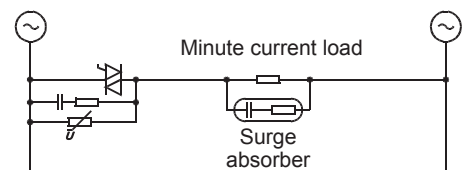

■Interlock

For loads such as forward/reverse contactors, etc., where a hazardous condition could result if switched ON simultaneously, an external interlock should be provided for interlocking along with an interlock in the PLC program as shown below.

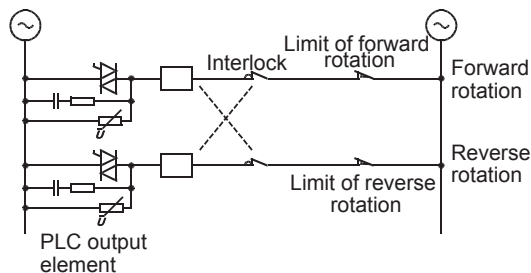

■In-phase

PLC output contacts (*1) should be used in an "in-phase" manner.

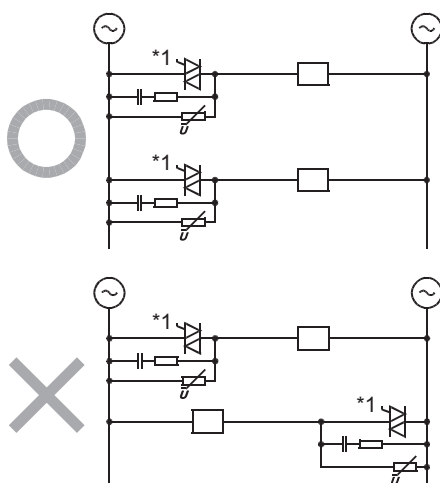

Output wiring example

Transistor output

■ Sink output type

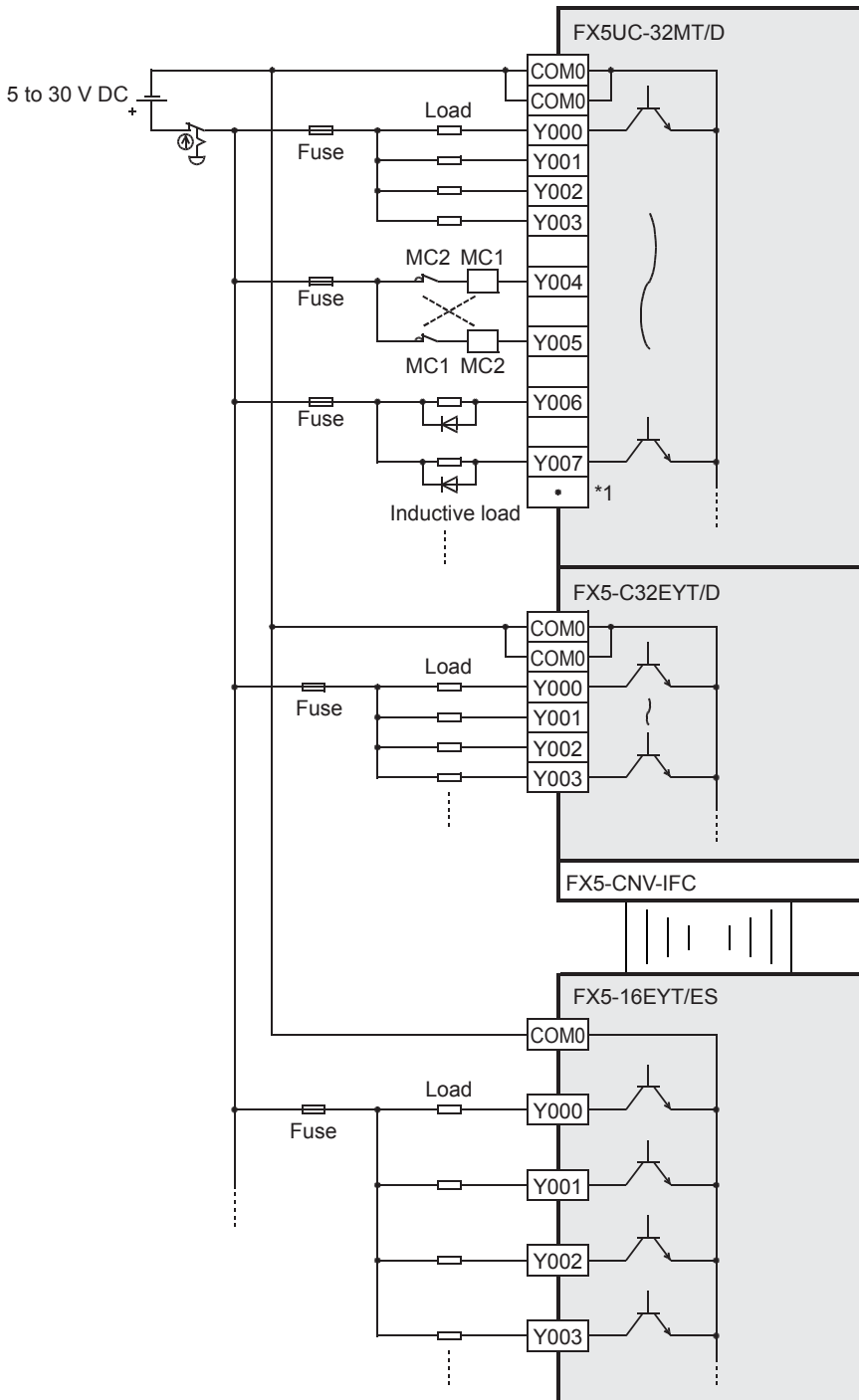

*1 "•" represents a vacant terminal.

■ Source output type

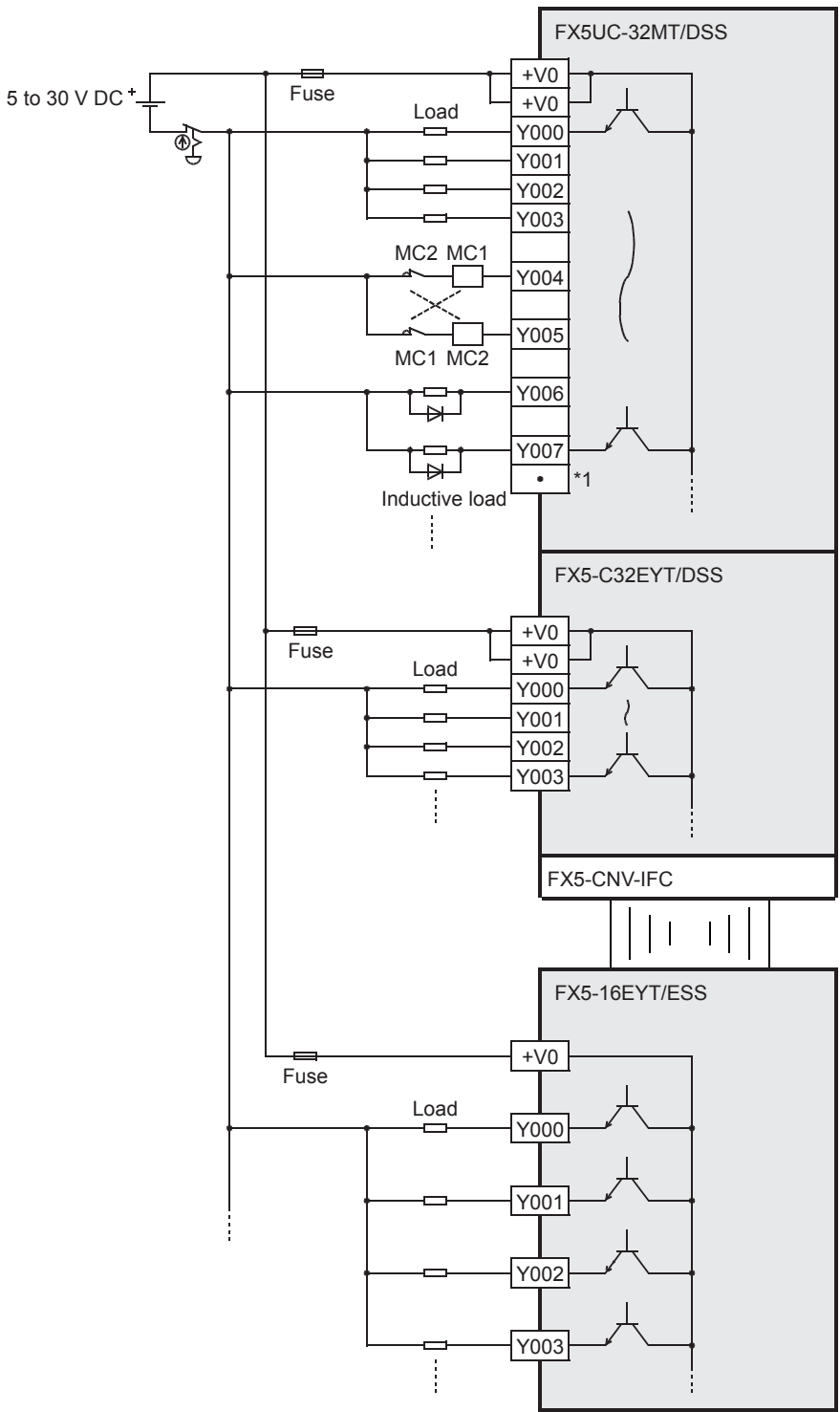

*1 "." represents a vacant terminal.

Relay output

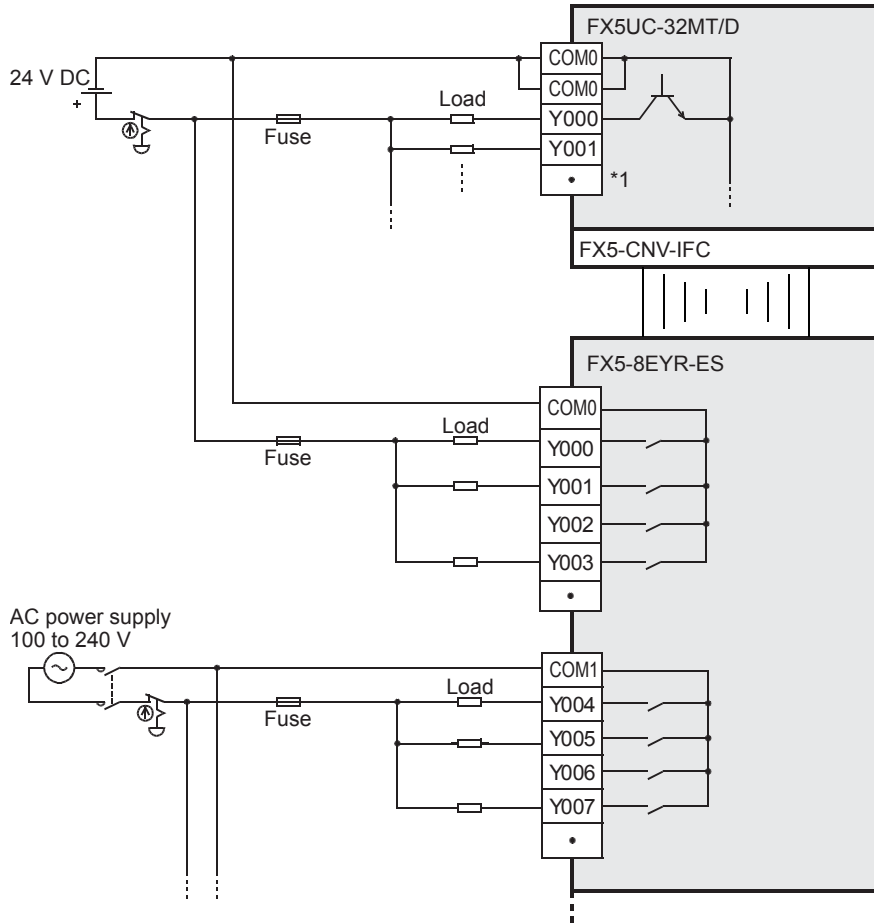

1 "" represents a vacant terminal.

Output wiring examples of terminal modules

FX-16E-TB, FX-32E-TB

Connected models: FX5UC-32MT/D, FX5-C32EYT/D, FX5-C32ET/D

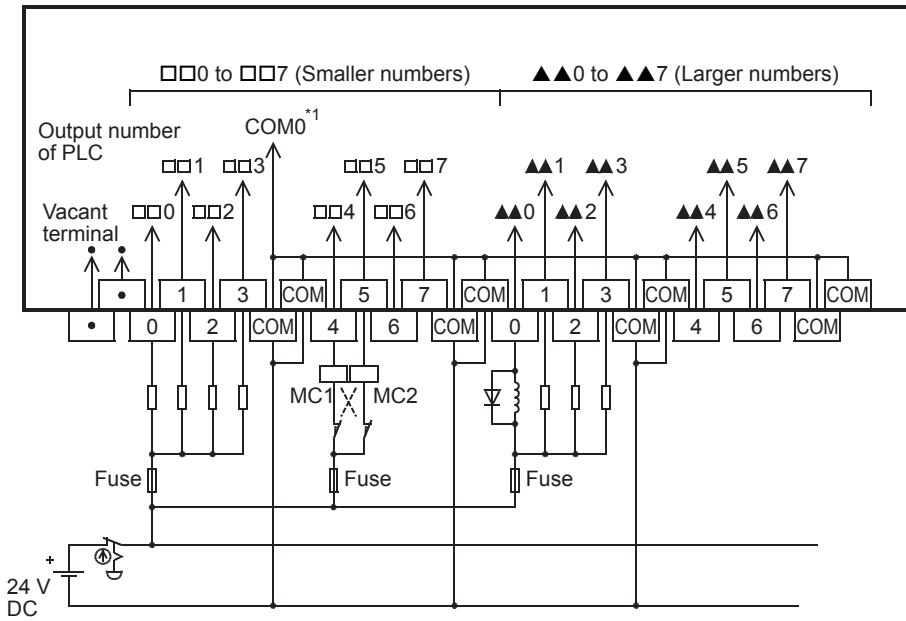

*1 Replace this number with the one of the connected connector.

FX-16E-TB/UL, FX-32E-TB/UL

Connected models: FX5UC-32MT/DSS, FX5-C32EYT/DSS, FX5-C32ET/DSS

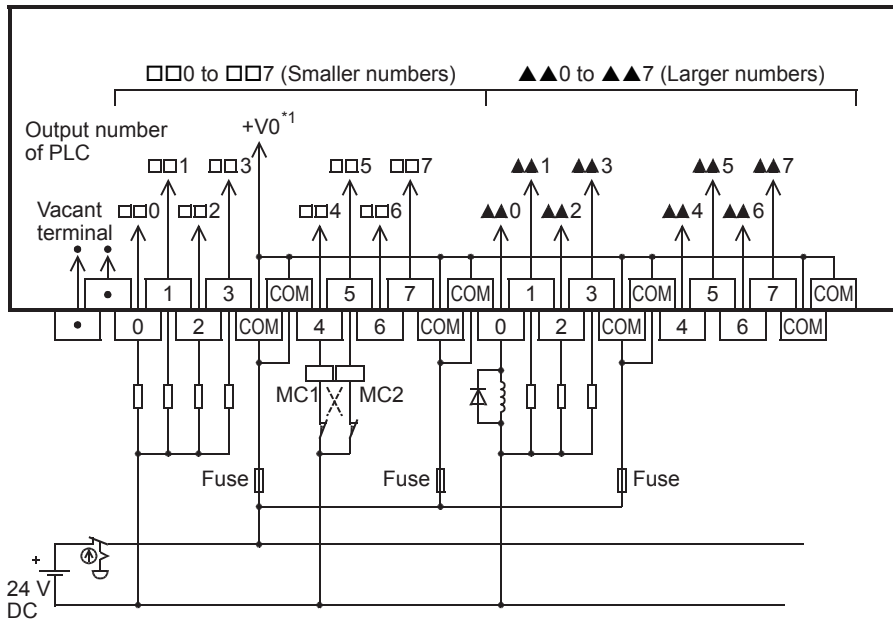

*1 Replace this number with the one of the connected connector.

FX-16EYR-TB, FX-16EYR-ES-TB/UL

Connected models: FX5UC-32MT/D, FX5-C32EYT/D, FX5-C32ET/D

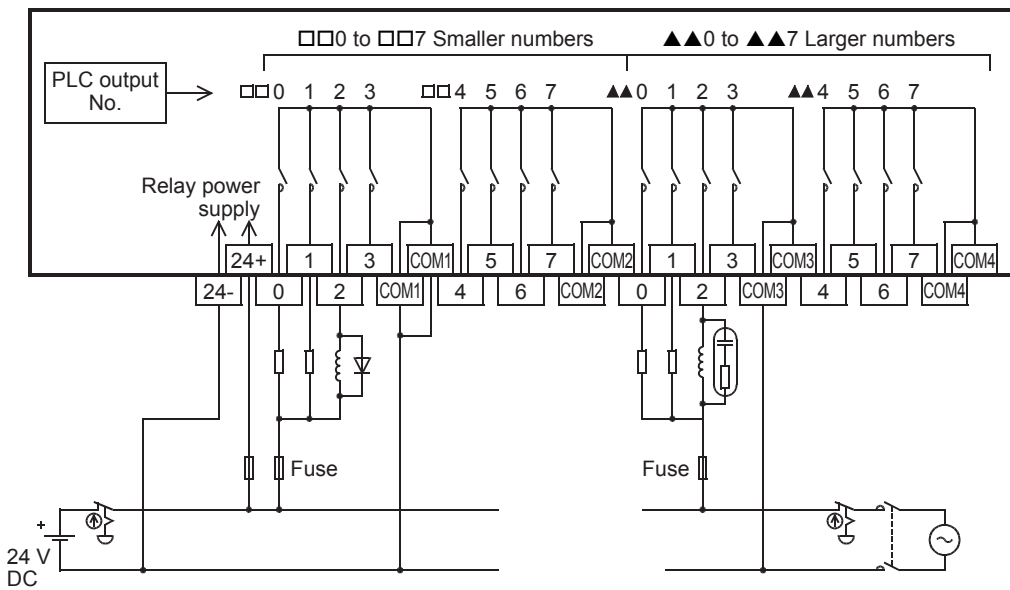

For external wiring precautions, refer to [Page 73 Wiring precautions](#).

For the life of a relay output contact, refer to [Page 71 Product life of relay output contacts](#).

FX-16EYT-TB

Connected models: FX5UC-32MT/D, FX5-C32EYT/D, FX5-C32ET/D

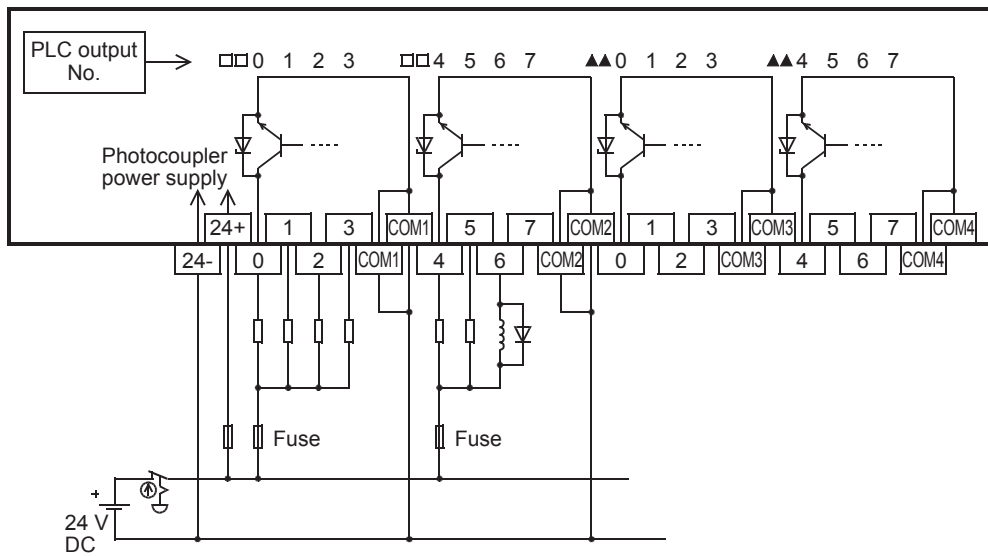

For external wiring precautions, refer to [Page 69 Wiring precautions](#).

FX-16EYT-ES-TB/UL

Connected models: FX5UC-32MT/DSS, FX5-C32EYT/DSS, FX5-C32ET/DSS

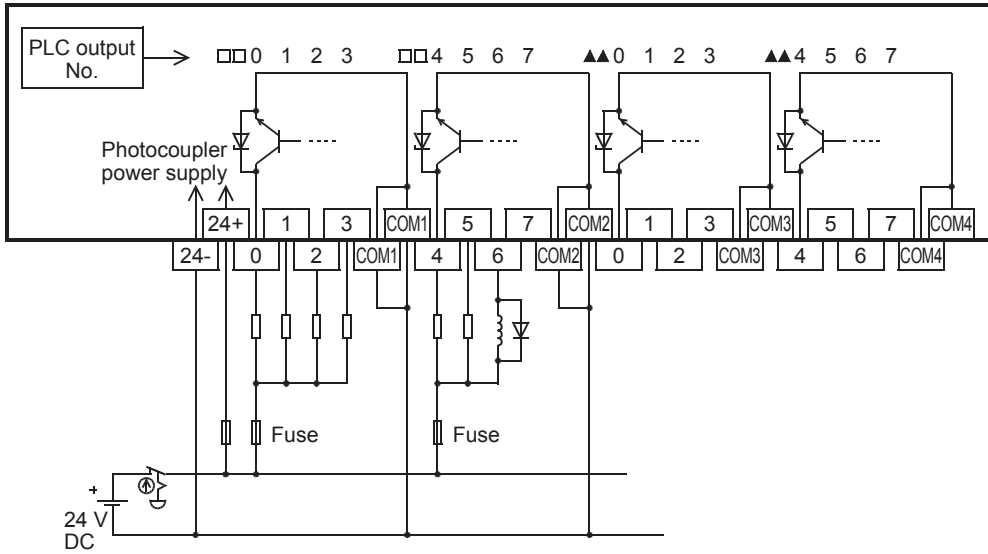

For external wiring precautions, refer to [Page 69 Wiring precautions](#).

FX-16EYT-ESS-TB/UL

Connected models: FX5UC-32MT/DSS, FX5-C32EYT/DSS, FX5-C32ET/DSS

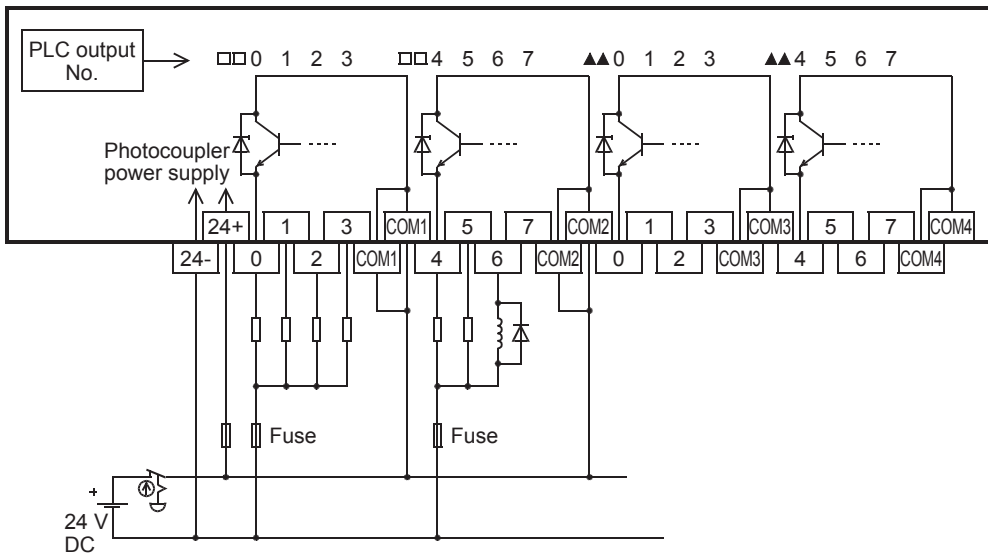

For external wiring precautions, refer to [Page 69 Wiring precautions](#).

FX-16EYS-TB

Connected models: FX5UC-32MT/D, FX5-C32EYT/D, FX5-C32ET/D

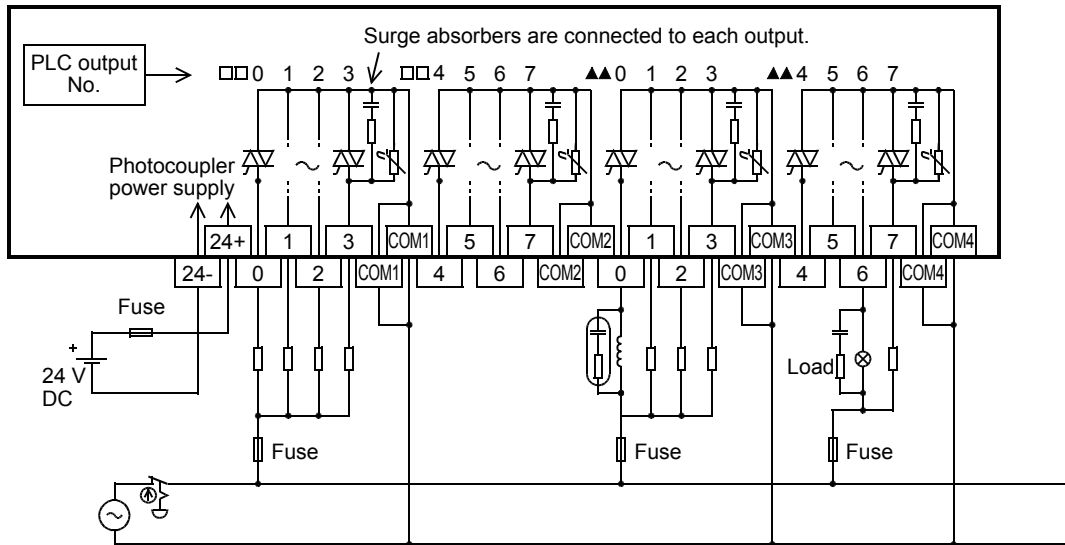

For external wiring precautions, refer to [Page 75 Wiring precautions](#).

FX-16EYS-ES-TB/UL

Connected models: FX5UC-32MT/DSS, FX5-C32EYT/DSS, FX5-C32ET/DSS

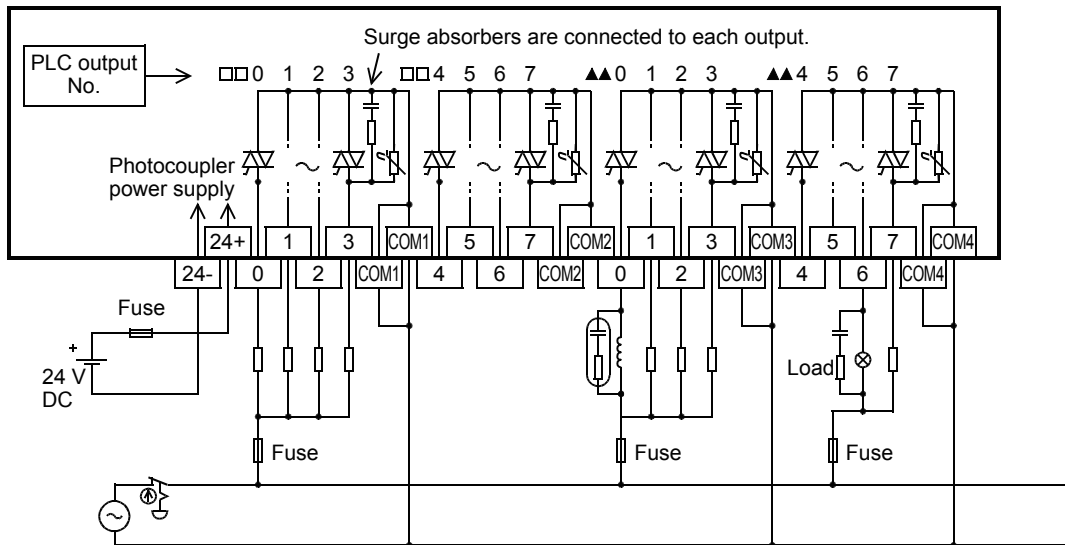

For external wiring precautions, refer to [Page 75 Wiring precautions](#).

6.7 Examples of Wiring for Various Uses

Notes about examples of wiring

The examples of wiring are given under the following conditions.

■Input/output number

The input/output numbers are the actual numbers on the program (They may differ from the numbers shown on the product terminals).

■Input/output specifications of products

Check the input/output specifications of products and examples of wiring.

- There are products for sink output and for source output.

■Examples of program

The examples of programming (instructions) are given based on the allocation of the input/output numbers for wiring.

For the instructions, refer to MELSEC iQ-F FX5 Programming Manual (Instructions, Standard Functions/Function Blocks).

Built-in positioning function

For wiring examples for the built-in positioning function, refer to MELSEC iQ-F FX5 User's Manual (Positioning Control).

Communication function

For wiring of the built-in RS-485 communication terminal blocks and communication adapters, refer to the following.

MELSEC iQ-F FX5 User's Manual (Serial Communication)

MELSEC iQ-F FX5 User's Manual (MODBUS Communication)

For wiring of the built-in Ethernet, refer to the following.

MELSEC iQ-F FX5 User's Manual (Ethernet Communication)

High-speed counter

Examples of wiring for high-speed counters are shown below.

When capturing pulses of a response frequency of 50 to 200 kHz, refer to Page 62 When a high-speed pulse is captured.

For details of the high-speed counters, refer to MELSEC iQ-F FX5 User's Manual (Application).

For the programs, refer to MELSEC iQ-F FX5 Programming Manual (Instructions, Standard Functions/Function Blocks).

1-phase 1-count

The wiring examples in this section use the following settings. When settings other than those in the table are used, use the examples shown in the following figures as references for wiring.

CH to be used	Pulse input mode	External preset input	External enable input	Operation mode
CH1	1-phase 1-input (S/W)	Invalid	Invalid	Normal mode

The settings of the high-speed counters are set by using the parameter settings of the engineering tool.

For details, refer to MELSEC iQ-F FX5 User's Manual (Application).

■ Example of wiring (NPN open collector transistor output rotary encoder)

- FX5UC-32MT/D

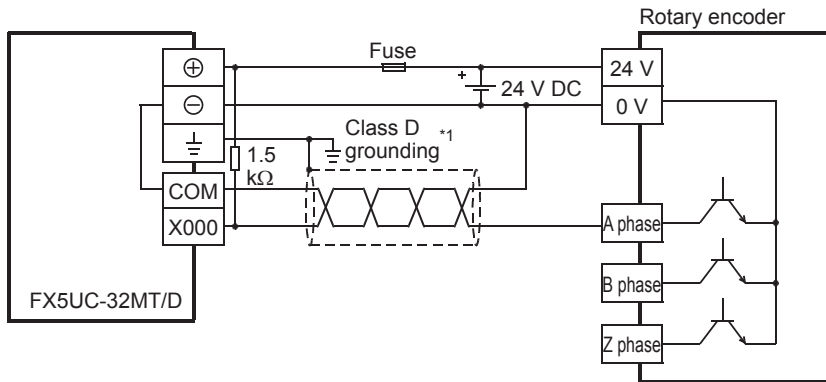

*1 The grounding resistance should be 100 Ω or less.

- FX5UC-32MT/DSS [Sink input wiring]

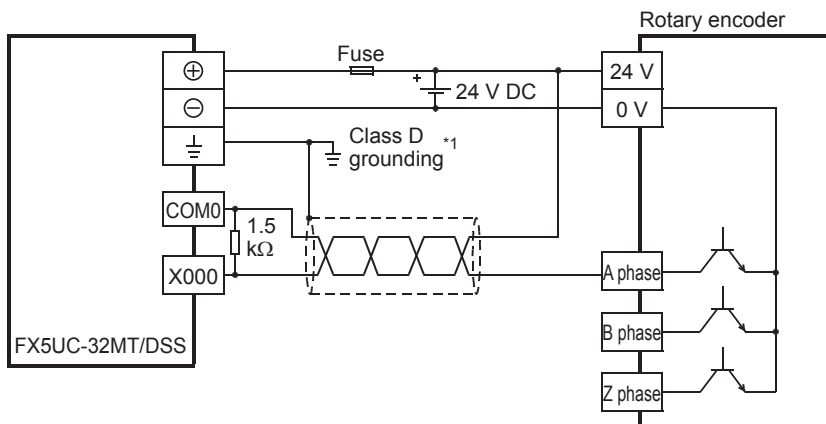

*1 The grounding resistance should be 100 Ω or less.

■ Example of wiring (PNP open collector transistor output rotary encoder)

- FX5UC-32MT/DSS [Source input wiring]

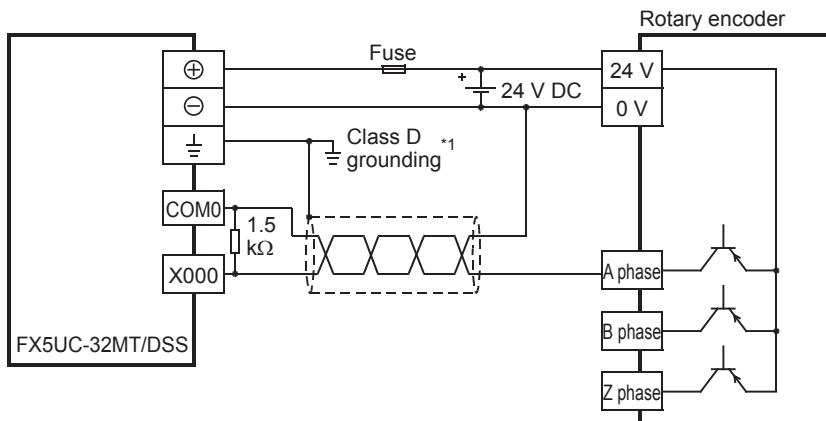

*1 The grounding resistance should be 100 Ω or less.

2-phase 2-count

The wiring examples in this section use the following settings. When settings other than those in the table are used, use the examples shown in the following figures as references for wiring.

CH to be used	Pulse input mode	External preset input	External enable input	Operation mode
CH2	2-phase 2-input	Invalid	Invalid	Normal mode

The settings of the high-speed counters are set by using the parameter settings of the engineering tool.

For details, refer to [GX Works3 Operating Manual](#).

■ Example of wiring (NPN open collector transistor output rotary encoder)

- FX5UC-32MT/D

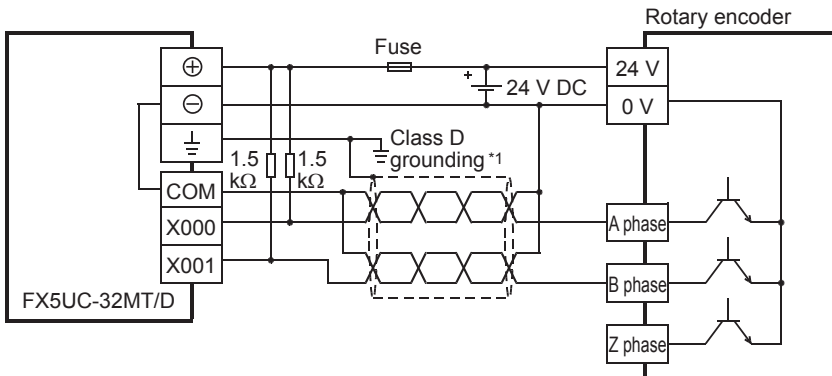

*1 The grounding resistance should be 100 Ω or less.

- FX5UC-32MT/DSS [Sink input wiring]

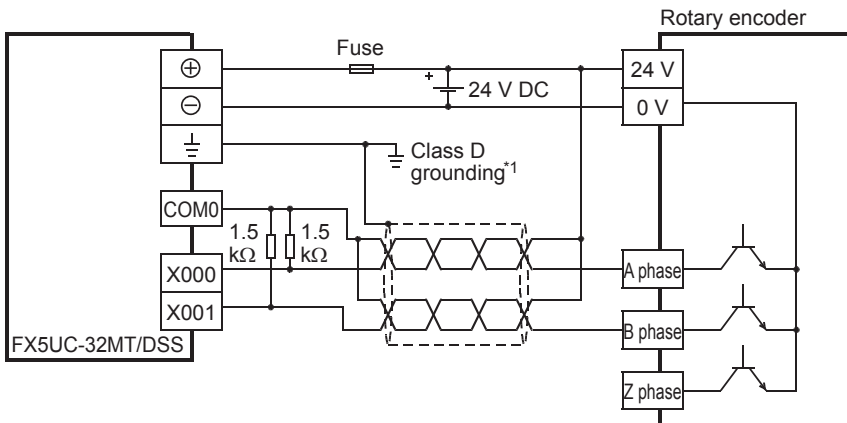

*1 The grounding resistance should be 100 Ω or less.

■ Example of wiring (PNP open collector transistor output rotary encoder)

- FX5UC-32MT/DSS [Source input wiring]

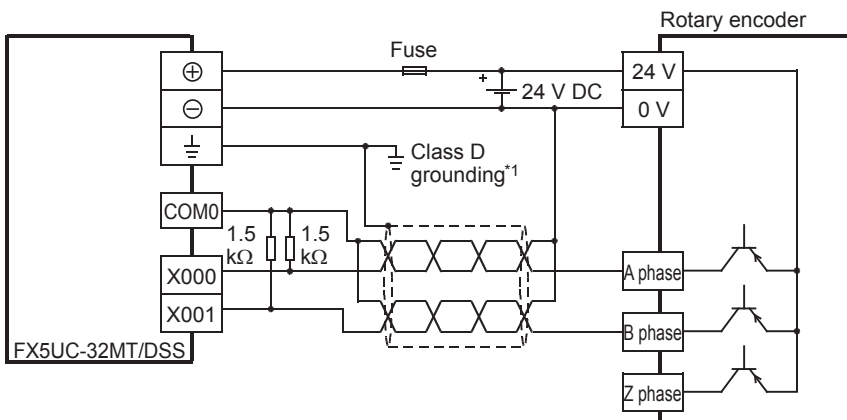

*1 The grounding resistance should be 100 Ω or less.

Interruption

Examples of wiring for when the input interruption function of the CPU module is used are shown below.

The same wiring is used for the pulse catch and pulse width measurement functions.

When capturing pulses of a response frequency of 50 to 200 kHz, refer to Page 62 When a high-speed pulse is captured.

For details of the input interruption function, pulse catch function, and pulse width measurement function, refer to MELSEC iQ-F FX5 User's Manual (Application).

Example of wiring

■3-wire sensor of NPN open collector transistor output

- FX5UC-32MT/D

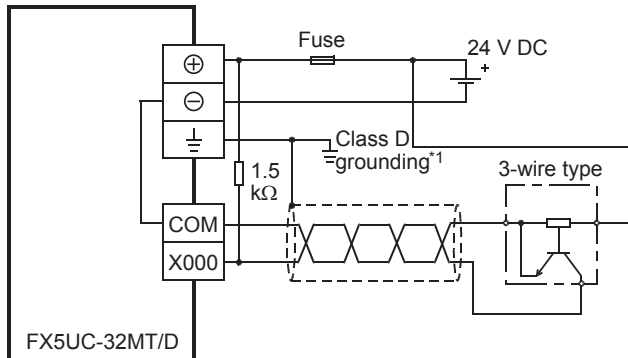

*1 The grounding resistance should be 100 Ω or less.

- FX5UC-32MT/DSS [Sink input wiring]

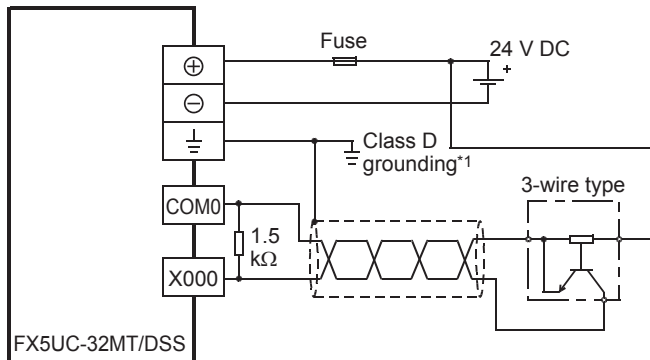

*1 The grounding resistance should be 100 Ω or less.

■3-wire sensor of PNP open collector transistor output

- FX5UC-32MT/DSS [Source input wiring]

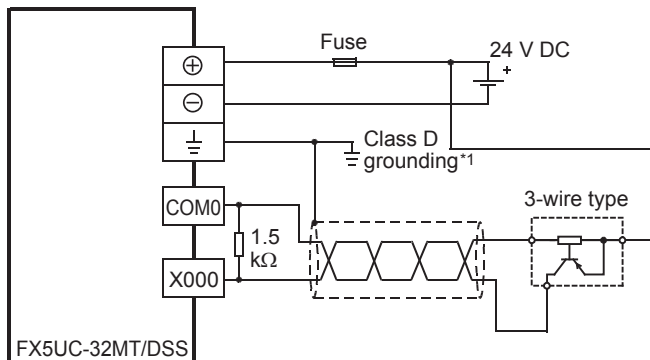

*1 The grounding resistance should be 100 Ω or less.

Digital Switch

When DSW instructions are used

Examples of wiring for capturing values from a 4-digit digital switch to the data register D100 are given below.

For the instructions, refer to [MELSEC iQ-F FX5 Programming Manual \(Instructions, Standard Functions/Function Blocks\)](#).

Example of program

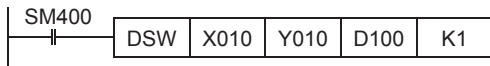

Example of wiring

- Sink wiring

The example is the wiring for the input/output of the FX5UC-32MT/D.

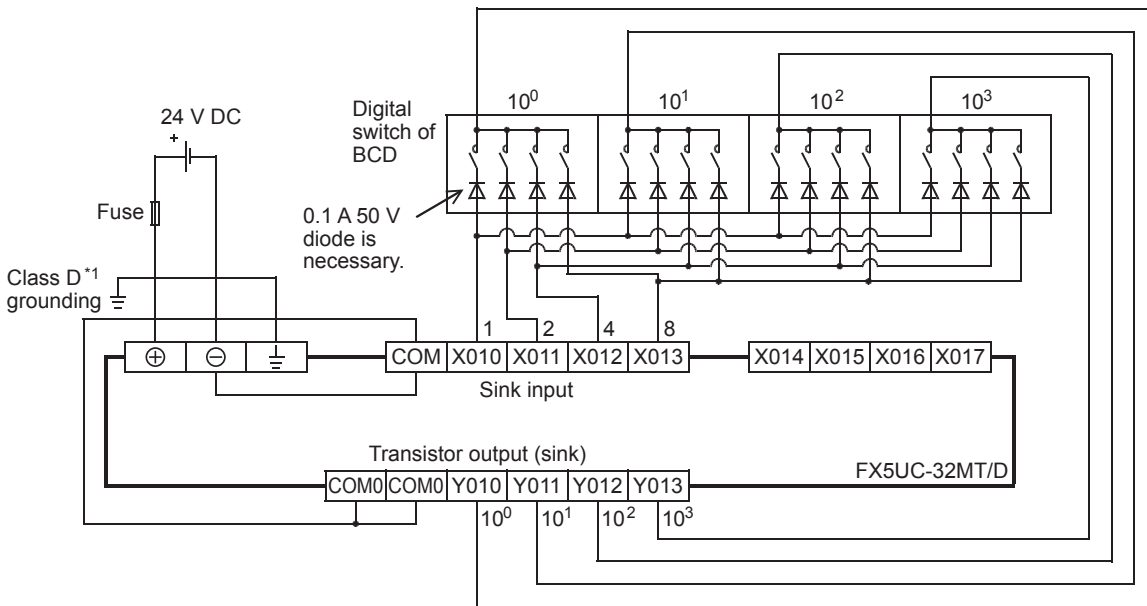

- Source wiring

The example is the wiring for the input/output of the FX5UC-32MT/DSS.

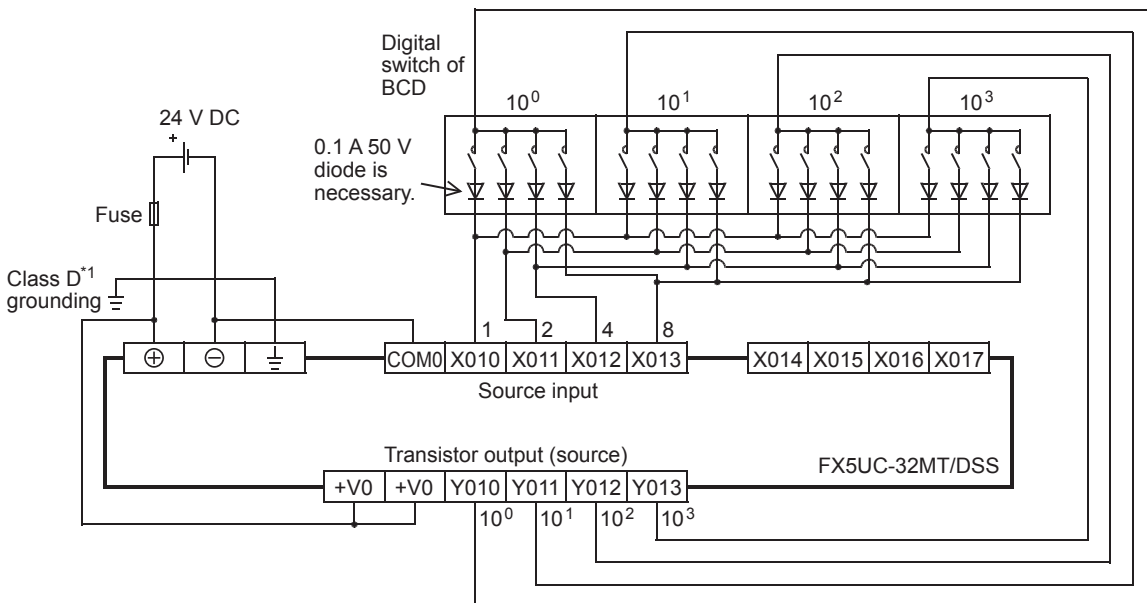

*1 The grounding resistance should be 100 Ω or less.

When BIN instructions are used

Examples of wiring for capturing values from a 2-digit digital switch to the data register D102 are given below.

For the instructions, refer to MELSEC iQ-F FX5 Programming Manual (Instructions, Standard Functions/Function Blocks).

Example of program



Example of wiring

- Sink wiring

The example is the wiring for the input/output of the FX5UC-32MT/D.

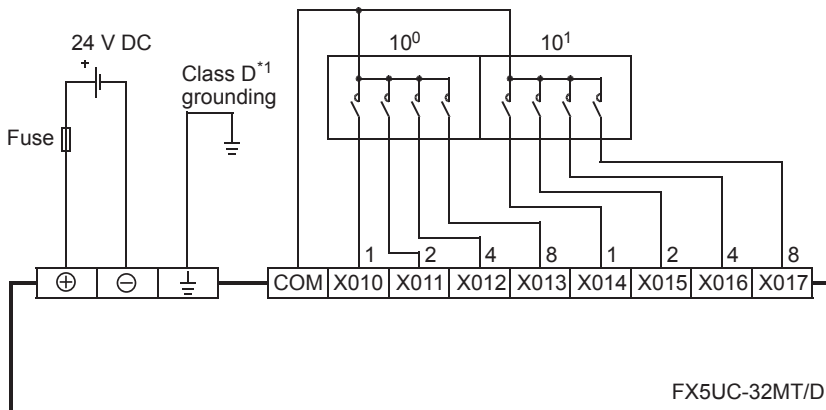

- Source wiring

The example is the wiring for the input/output of the FX5UC-32MT/DSS.

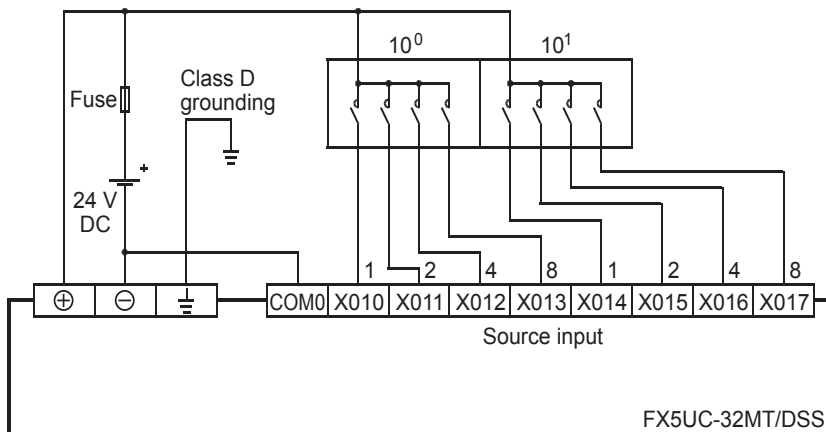

*1 The grounding resistance should be 100 Ω or less.

Input Matrix

Examples of wiring to take ON/OFF status of 24 switches by using MTR instructions are given below.

For the instructions, refer to MELSEC iQ-F FX5 Programming Manual (Instructions, Standard Functions/Function Blocks).

Programming examples

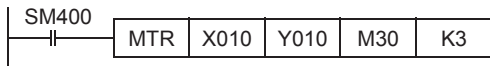

Wiring examples

- Sink wiring

The example is the wiring for the input/output of the FX5UC-32MT/D.

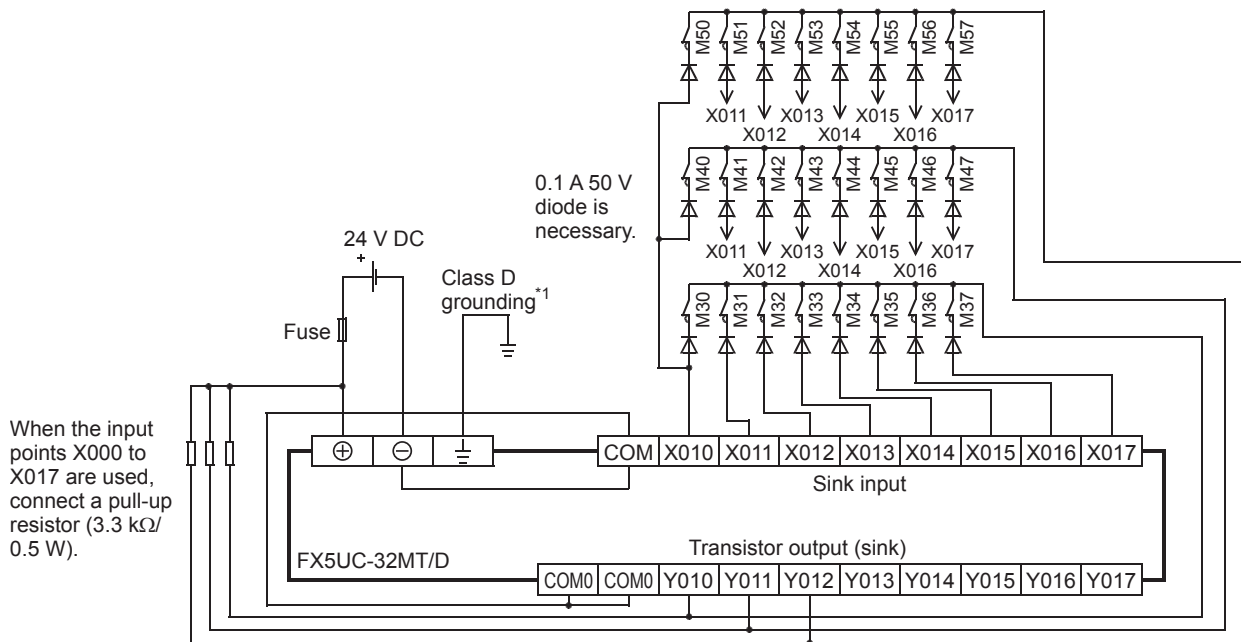

- Source wiring

The example is the wiring for the input/output of the FX5UC-32MT/DSS.

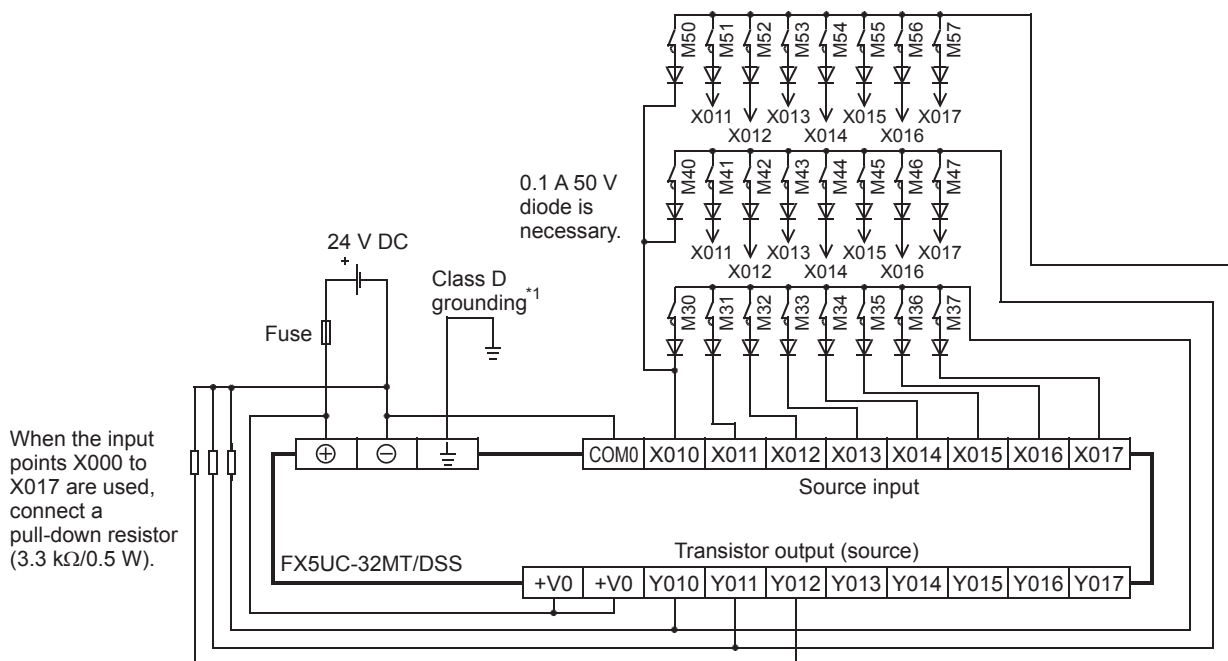

*1 The grounding resistance should be 100 Ω or less.

Seven Segment with Latch

For the instructions, refer to MELSEC iQ-F FX5 Programming Manual (Instructions, Standard Functions/Function Blocks).

When SEGL instructions are used

Examples of wiring for displaying the current value of D100 on the 4-digit 7-segment display are given below.

Example of program

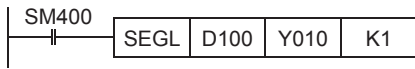

Example of program wiring

- Sink wiring

The example is the wiring for the input/output of the FX5UC-32MT/D.

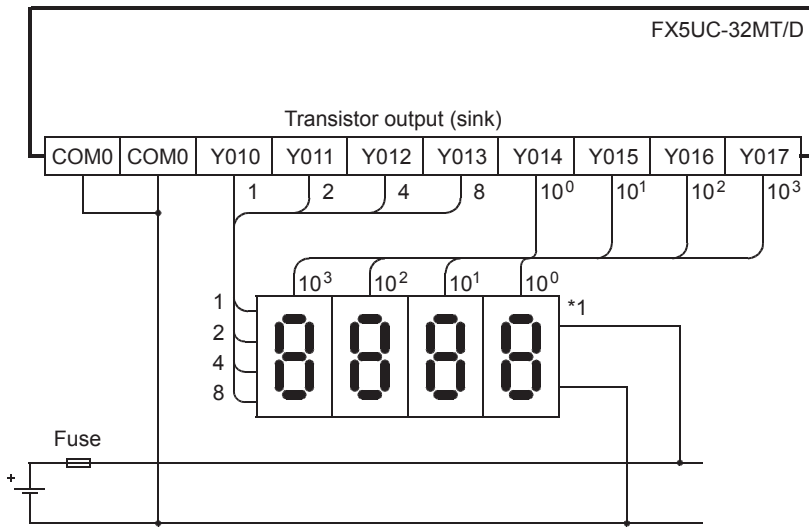

7-segment display used for sink wiring (for transistor output)

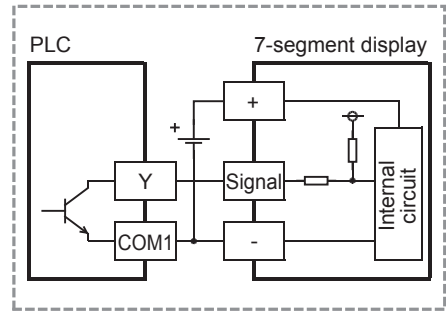

- Source wiring

The example is the wiring for the input/output of the FX5UC-32MT/DSS.

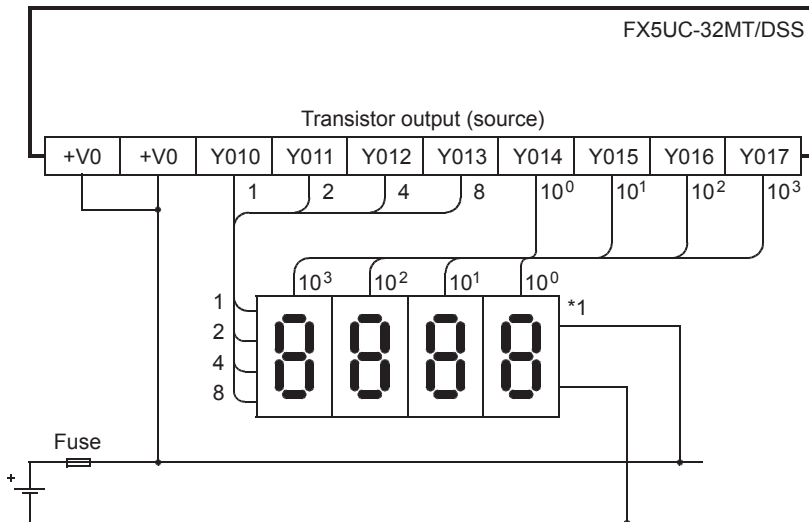

7-segment display used for source wiring (for transistor output)

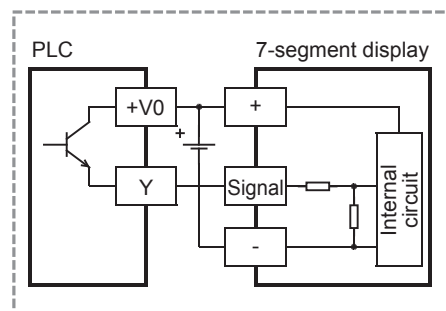

*1 Use a 7-segment display with a latch and a built-in BCD decoder.

When BCD instructions are used

Examples of wiring for displaying the current value of D100 on the 2-digit 7-segment display are given below.

Example of program

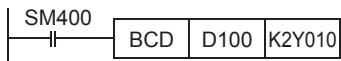

Examples of wiring

- Sink wiring

The example is the wiring for the input/output of the FX5UC-32MT/D.

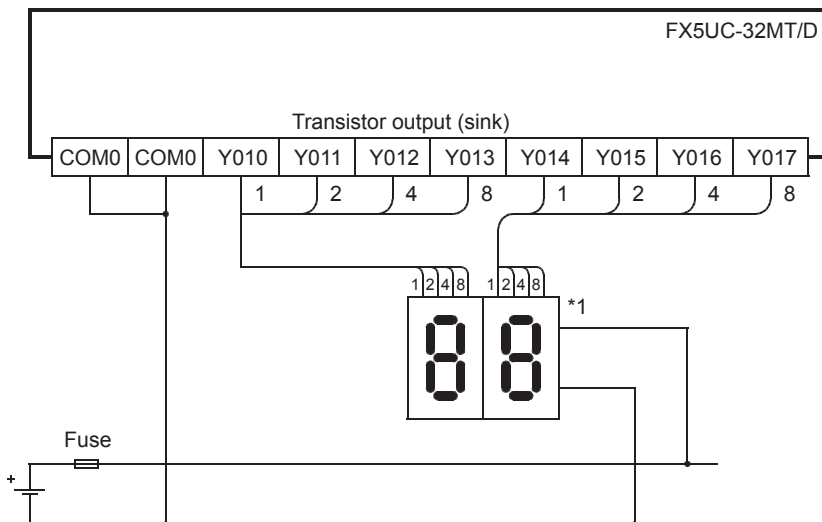

7-segment display used for sink wiring (for transistor output)

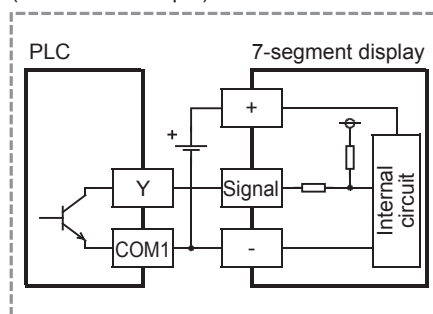

- Source wiring

The example is the wiring for the input/output of the FX5UC-32MT/DSS.

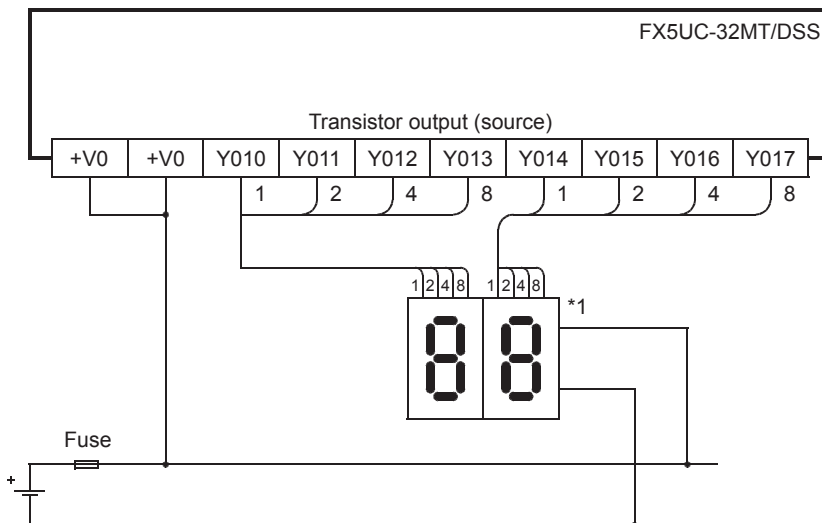

7-segment display used for source wiring (for transistor output)

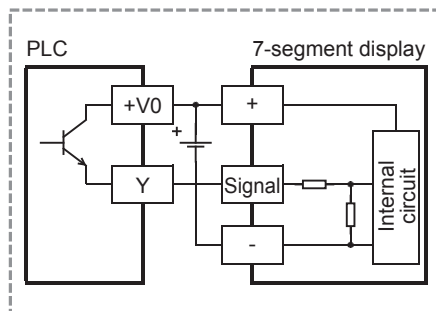

*1 Use a 7-segment display with a latch and a built-in BCD decoder.

7 OPERATION ADJUSTMENT

7.1 Preparation for Operation

Preliminary inspection

Incorrect connection of the power supply terminal, contact of the DC input wire and power supply wire, or short-circuiting of output wires may result in serious damage.

Before applying power, check that the power supply and ground terminals are connected correctly and input/output devices are wired properly.

Dielectric withstand voltage test and insulation resistance test

The dielectric withstand voltage and insulation resistance test of the PLC should be measured in accordance with the following procedure.

1. Remove all input/output wires and power supply wires from the PLC.
2. Connect a crossing wire to each of the PLC terminals (power supply terminal, input terminals and output terminals) except the ground terminal. For the dielectric withstand voltage test of each terminal, refer to the general specifications for the product (refer to  Page 17 Generic Specifications).
3. Measure the dielectric withstand voltage and insulation resistance between each terminal and the ground terminal.
 - Dielectric withstand voltage 1.5 kV AC or 500 V AC for 1 min (The terminals vary in dielectric withstand voltage.)
 - Insulation resistance 10 MΩ or higher by 500 V DC insulation resistance tester

Procedure until operation

The procedure until operation is explained below.

1. Turn on the power of the system.

Check the following items before turning on the power of the system. When the CPU module with the factory default setting is powered on, the ERR LED flashes because the module has no programs.

- The power connector is connected correctly.
- The power supply voltage is within the specified range.
- The CPU module is in the stopped status.

2. Connection with a personal computer

Connect the CPU module with a personal computer on which an engineering tool has been installed. ( Page 93 Connection with a personal computer)

3. Format the CPU built-in memory.

Format the CPU built-in memory using the engineering tool. ( GX Works3 Operating Manual)

4. Parameter setting

Set the parameters needed for startup.

( GX Works3 Operating Manual)

- System parameters
- CPU parameters
- Module parameters

5. Programming

Create a program using the engineering tool. ( MELSEC iQ-F FX5 User's Manual (Application))

6. Write the parameters and the program.

Write the parameters and the program set with the engineering tool into the CPU module.

( GX Works3 Operating Manual)

7. Reboot the system.

Reboot the system by any of the following methods.

- Turning off and on the power
- Resetting the CPU module ( Page 95 Resetting method)

8. Check errors.

Check the ERR LED of the CPU module. If an error has occurred, check the contents of the error with Module Diagnostics (CPU Diagnostics) of the engineering tool and eliminate its cause.

9. Run the program.

Set the CPU module to the RUN status and make sure that the P.RUN LED of the CPU module lights up.

Connection with a personal computer

Connect the CPU module with a personal computer on which an engineering tool has been installed.

The system configuration examples and GX Works3 settings are described below.

For details, refer to  GX Works3 Operating Manual.

Direct connection

Setting examples for accessing the CPU module that is directly connected with a personal computer are shown below.

■ Ethernet connection

- Ethernet port direct connection

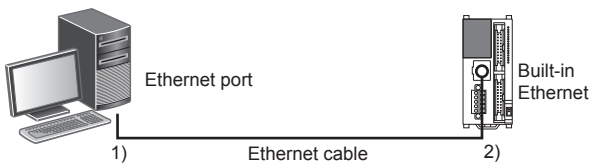

GX Works3 settings

No.	Item	Selection item	Internal setting	Input value
1)	PC side I/F	Ethernet Board	—	—
2)	PLC side I/F	PLC Module		Ethernet Port Direct Connection
	Other Station Setting	No Specification	Check at Communication Time	30 seconds
			Retry Times	0 times

Point

For the FX5 CPU module, the Ethernet adapter on the personal computer side used for the Ethernet port direct connection can be specified. Click the [CPU Module Direct Coupled Setting] button on the "Specify Connection Destination Connection" window to display the "CPU Module Direct Coupled Setting" window. Select the adapter on the window.

- Connection via HUB

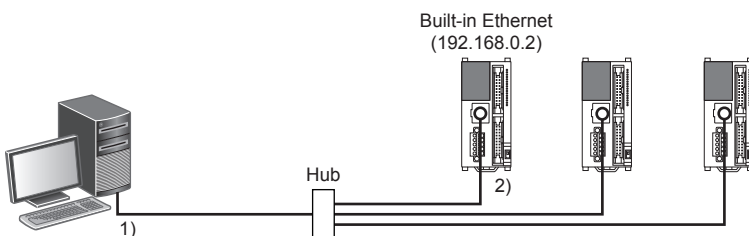

GX Works3 settings

No.	Item	Selection item	Internal setting	Input value	
1)	PC side I/F	Ethernet Board	—	—	
2)	PLC side I/F	PLC Module	Connection via HUB	IP Address	192.168.0.2
				Response Waiting Time	2 seconds
	Other Station Setting	No Specification	Check at Communication Time	30 seconds	
			Retry Times	0 times	

Serial connection

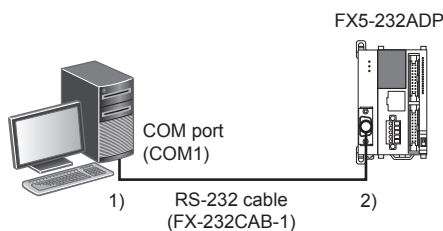

GX Works3 settings

No.	Item	Selection item	Internal setting	Input value
1)	PC side I/F	Serial/USB	RS-232C	—
			COM Port	COM1
			Transmission Speed	115.2Kbps
2)	PLC side I/F	PLC Module	PLC Mode	FX5CPU
	Other Station Setting	No Specification	Check at Communication Time	30 seconds
			Retry Times	0 times

7.2 Operation and Test

Self-diagnostic function

When the power of the CPU module is turned on, the self-diagnostic function to check for errors starts in the module. The CPU module boots when there is no error with the hardware, parameters, and program.

When there are no errors, the module enters the RUN status (the P.RUN LED turns on) in response to the RUN instruction (☞ Page 95 Running, Stopping, and Resetting). If any error is detected, the "ERR" LED flashes or lights up.

Monitoring and debugging

The ON/OFF status of PLC's devices, current values or set values can be monitored or changed by using engineering tools. For details, refer to [GX Works3 Operating Manual](#).

7.3 Running, Stopping, and Resetting

Methods of running, stopping, and resetting

The following two methods of running, stopping, and resetting the FX5UC CPU modules are provided.

Using the RUN/STOP/RESET switch

The operation status of the CPU module can be changed with the RUN/STOP/RESET switch.

Setting the RUN/STOP/RESET switch to the RUN position runs the program. Setting the switch to the STOP position stops the program.

Resetting method

Resetting can be performed with the RUN/STOP/RESET switch. Resetting is not performed immediately after the RUN/STOP/RESET switch is set to the RESET position.

Perform the following procedure to reset with the RUN/STOP/RESET switch.

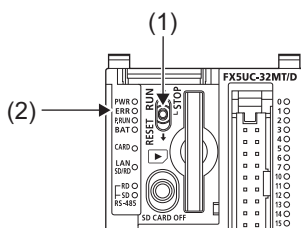

1. Set the RUN/STOP/RESET switch (1) to the RESET position for at least one second.
2. Make sure that the ERR LED (2) flashes several times and the light goes off.
3. Return the RUN/STOP/RESET switch to the STOP position.

Remote operation

The operation status of the CPU module can be changed externally with the RUN/STOP/RESET switch set to the RUN position. The operation status of the CPU module can be set to the PAUSE status.

Remote operation can be performed by either of the following methods.

- Using contacts (MELSEC iQ-F FX5 User's Manual (Application))
- Using engineering tools (GX Works3 Operating Manual)
- Using external devices using SLMP (MELSEC iQ-F FX5 User's Manual (SLMP))

Use of several running/stopping methods

When the RUN/STOP/RESET switch and RUN contact are used

- The RUN/STOP status of the PLC is determined by the conditions shown in the following table.

RUN/STOP/RESET switch status	Condition of the input specified as the RUN terminal by parameters	CPU module status
RUN	RUN	RUN
	STOP	STOP
STOP	RUN	STOP
	STOP	STOP

8 MAINTENANCE AND INSPECTION

8.1 Daily Inspection



Perform the following inspections on a daily basis.

Item	Inspection item	Description	
1	Installation status of the module	Mounting status of the module	The module should be securely mounted.
		Looseness of cover	The cover should not be off.
2	Connection status	Looseness of terminal screws	Retighten the terminal screws.
		Proximity of crimp terminals	Check the proximity between crimp terminals and correct the clearance.
		Looseness of connectors	Connect cable connectors securely.
3	LED status	Check that the LED status is normal.  Page 101 Checking with LEDs User's manuals for each module	

8.2 Periodic Inspection

Perform the following inspections once or twice every 6 months to a year.

Also perform the inspections when facilities have been relocated or modified or when wiring has been changed.

Item	Inspection item	Description	
1	Ambient environment	Operating ambient temperature	The temperature in the panel should be 0 to 55°C (32 to 131°F).
		Operating ambient humidity	The humidity in the panel should be 5 to 95%RH.
		Working atmosphere	Free from corrosive or flammable gas and excessive conductive dust
2	Power supply voltage	Voltage within the specified range should be supplied.	
3	Installation status	Dirt, foreign matter	Wipe away any dirt or foreign matter. Clean the module.
4	Connection status	Looseness of terminal screws	Retighten the terminal screws.
		Proximity of crimp terminals	Check the proximity between crimp terminals and correct the clearance.
		Looseness of connectors	Connect cable connectors securely.
5	Battery	BAT LED	The BAT LED should be turned off. When the BAT LED lights up, replace the battery with new one.
		Period following the battery purchase	Replace the battery with new one if 5 years or more have passed since the battery was purchased.
		OFF status of SM51 (SM8005) and SM52 (SM8006)	SM51 (SM8005) and SM52 (SM8006) should be off. If SM51 (SM8005) and SM52 (SM8006) are on, replace the battery with new one.
6	Module Diagnostics (CPU Diagnostics)	The normal status of the system should be checked with the Module Diagnostics (CPU Diagnostics).  Page 103 Module Diagnostics (CPU Diagnostics)	
7	Relay contacts	Check the product life of relay outputs.  Page 71 Product life of relay output contacts	

Point

The product life of relay contacts varies considerably depending on the load type used. Note that loads generating reverse electromotive force or rush current may cause poor contact or deposition of contacts which may lead to considerable reduction of the contact product life.

 Page 71 Product life of relay output contacts

8.3 Battery

Part names

The Latch device memory and clock data upon power interruption. The battery is not incorporated in the CPU module during shipment from the factory. Order it if necessary. Parameter setting is required to back up the device memory and clock data. (☞ Page 98 Setting an optional battery using the engineering tool)

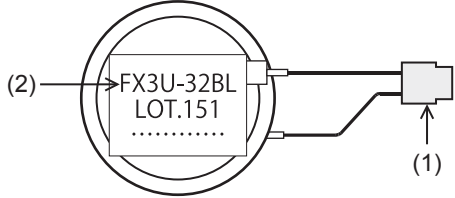
External appearance	No.	Name	Description
	(1)	Connector	Connected to the battery connector of the CPU module.
	(2)	Nameplate	Displays the model name and lot number.

Specifications

The following shows functional specifications of the battery.

Item	FX3U-32BL
Battery type	Lithium manganese dioxide battery
Nominal voltage	3.0 V
Life	Standard life: 5 years (at ambient temperature of 25°C (77°C))* ¹

*1 The life of the battery changes with respect to ambient temperature. (☞ Page 98 Battery life and replacement guidelines)

Battery attachment

The battery is not incorporated in the CPU module during shipment from the factory. To use the battery, attach it following the procedure below. Parameter setting is required to back up the device memory and clock data using the battery. (☞ Page 98 Setting an optional battery using the engineering tool)

Attachment procedure

1. Turn the power supply off.
2. Remove the battery cover (A in the figure below).

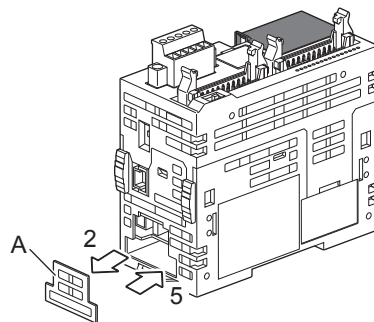

3. Push the battery into the battery holder (B in the figure below).
4. Insert the battery connector (C in the figure below) of the battery.

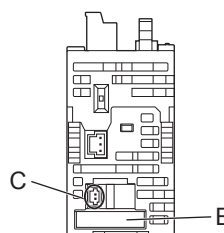

5. Attach the battery cover.

Setting an optional battery using the engineering tool

The following setting is required when the capacity of the latch device/latch label is increased using the optional battery. Note that the battery does not back up the data if the following setting is not provided.

- Select the Navigation window⇒[Parameter]⇒[FX5UCPU]⇒[CPU Parameter]⇒[Memory/Device Setting]⇒[Device/Label Memory Area Setting]⇒[Option Battery Setting]⇒[Mounted]

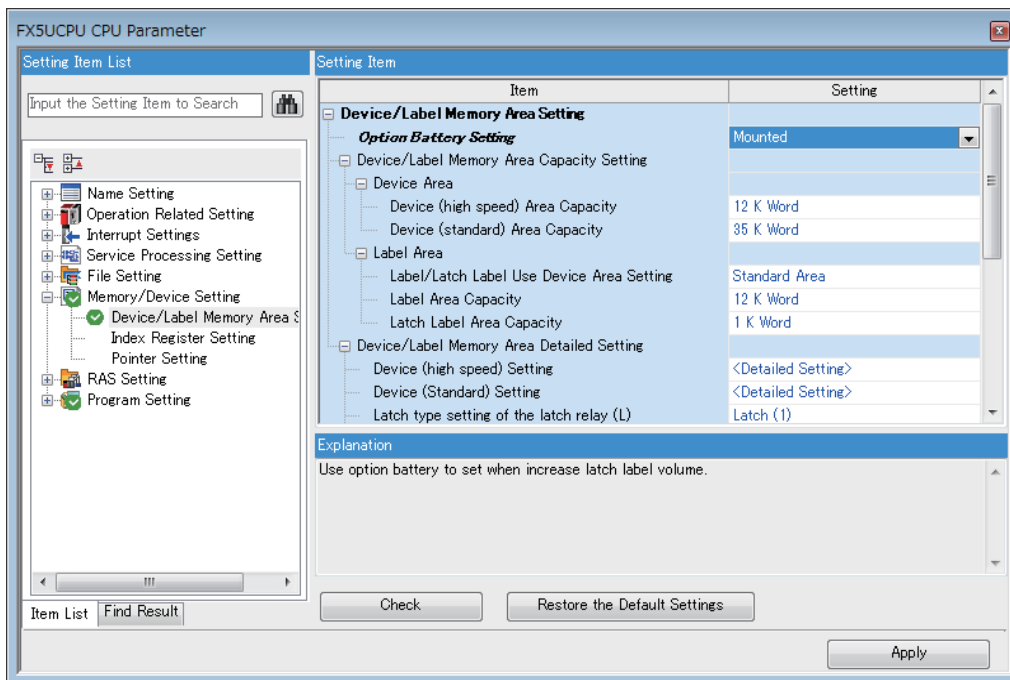

Battery replacement

Battery life and replacement guidelines

When the battery voltage is low, the BAT LED is lit red while the power is on, and SM51 (SM8005) and SM52 (SM8006) are turned ON. The memory can be retained for about one month after the LED turned on. However, the drop in battery voltage may not be detected immediately. Prepare a new battery and replace the battery with new one promptly.

Point

Standard life of FX3U-32BL: 5 years (at ambient temperature of 25°C (77°F))

The life of the battery changes with respect to ambient temperature.

When planning for battery replacement, please estimate the battery life according to the graph below and order replacement batteries in advance.

Battery life vs. temperature

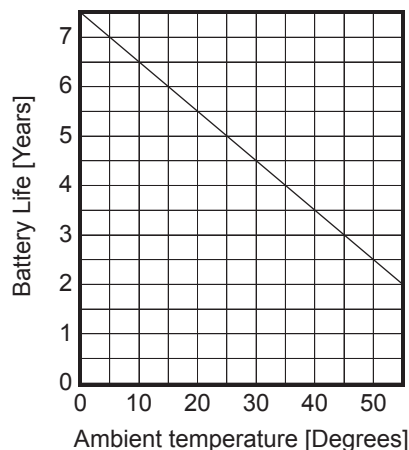

Replacement procedure

If the battery voltage is reduced, replace it following the procedure below.

Even with the battery removed, the built-in capacitor holds the data of the memory for the power interruption time (20 sec.). Battery replacement steps 3 and 4 must be completed within 20 seconds. If the time taken for battery replacement is longer than the power interruption time, the data of the memory may be lost.

1. Turn the power supply off.
2. Remove the battery cover (A in the figure below).

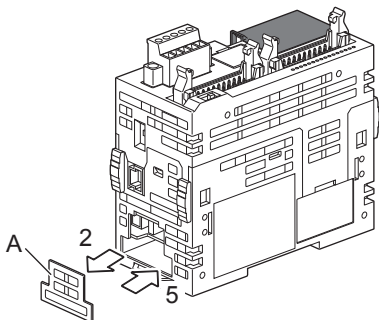

3. Disconnect the battery connector (B in the figure below) from the old battery, and remove the battery from the battery holder (C in the figure below).

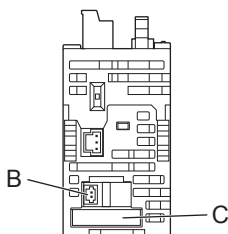

4. Install the new battery. (➔ Page 97 Battery attachment)
5. Attach the battery cover.

Point

- After replacing the battery, check whether the devices set by the latch and clock data are backed up correctly, confirm safety, and then run the PLC.
- If the devices set by the latch are not backed up correctly, clear them, and set their initial values and clock data again if necessary.

Reading the date of manufacture

How to read the battery lot number

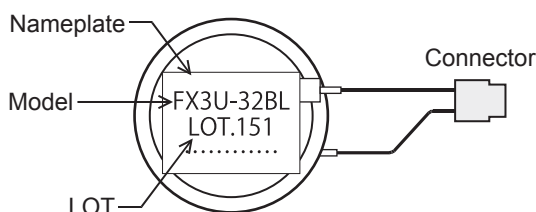

Month (Example: January): 1 to 9 = January to September,
X = October, Y = November, Z = December
Year (Example: 2015): Last two digits of year

Special relay for low battery voltage

Prepare a system which allows constant external monitoring of the battery status, using a GOT, etc.

- SM52 (SM8005)

The special relay turns ON when the battery voltage is the specified value or less.

The special relay turns OFF when the battery voltage returns is normal.

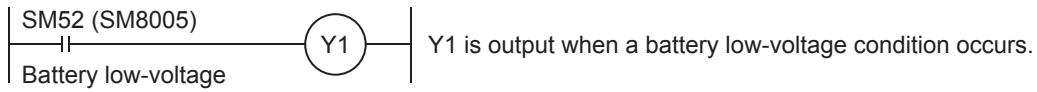

- SM51 (SM8006)

The special relay turns ON when the battery voltage is the specified value or less.

The special relay status ON even when the battery voltage is normal.

- SD8005

Battery voltage can be monitored.

9 TROUBLESHOOTING



Details on errors occurring in the system, their causes, and corrective actions are explained below. For details on troubleshooting for each module, refer to the manuals for the module.

Point

Saving the programs and devices used at the occurrence of an error helps identifying the cause of the error. ( Page 105 Backing Up the Data)

9.1 Troubleshooting Procedure

If an error occurs, perform troubleshooting in the following order.

1. Check that each module is properly mounted and wired.
2. Check the LEDs of the CPU module. ( Page 101 Checking with LEDs)
3. Check the LEDs of each intelligent function module. (Manuals for each module)
4. Connect the engineering tool and execute the Module Diagnostics (CPU Diagnostics). The error cause and the action to be taken can be displayed. ( Page 103 Module Diagnostics (CPU Diagnostics))
5. Check the cause of the error and take corrective actions.

9.2 Checking with LEDs

Check the module status with LEDs as a means to perform the primary diagnosis.

Checking the PWR LED

If the PWR LED is turned off, check the following items.

Item to check	Cause and action
Measure the voltage supplying to the CPU module.	If the power source is not supplying the proper voltage, provide a power source that does.
Remove extension modules and all wiring other than the one for the power supply, and turn on the power supply.	If the PWR LED turns on in this condition, or overloaded. Reconnect the modules and wire one by one to identify the cause.

If the PWR LED still does not turn on even after the items shown above are checked, there may be a hardware issue. Consult your local Mitsubishi Electric representative.

Checking the BAT LED

If the BAT LED turns on, check the following items.

The LED is valid when the optional battery is installed and the LED is set to "display" for battery errors by using the parameter.

Item to check	Cause and action
Check the installation of the battery.	Install the battery properly.
Check the battery voltage.	If the battery voltage is reduced, replace the battery with a new one. Battery voltage can be monitored with PLC data register SD8005. ( Page 97 Battery)

Checking the ERR LED

If the ERR LED flashes

If the ERR LED flashes, check the following items.

Item to check	Cause and action
Write system parameters, CPU parameters, and program files, and turn on the power supply again.	Programs or parameters may not be written or damaged. Since a CPU module with the factory default setting has no programs, the ERR LED flashes.

If the ERR LED turns on

If the ERR LED turns on, check the following items.

Item to check	Cause and action
Set the CPU module to the STOP status and turn on the power supply again.	When the ERR LED turns off, a watchdog timer error has probably occurred. Take any of the following measures. <ul style="list-style-type: none">• Review the program and avoid the maximum value (SD524, SD525) of the scan time exceeding the setting value of the scan time monitoring time which was set with parameters.• Check that the input used for input interruption or pulse catch is not being abnormally turned on and off in one scan.• Check that the frequency of the pulse input to the high-speed counter is within the specified range.• Add some WDT instructions to the program and reset the watchdog timer several times in one scan.
Provide a different power supply to the CPU module.	If the ERR LED turns off, noise may have affected the module. Consider taking the following measures. <ul style="list-style-type: none">• Check the ground wiring, and reexamine the wiring route and installation location.• Fit a noise filter onto the power supply line.

If the ERR LED still does not turn off even after the items shown above are checked, there may be a hardware issue. Consult your local Mitsubishi Electric representative.

Checking the P.RUN LED

If the P.RUN LED is turned off, check the status of the ERR LED and take corrective actions. (Page 102 Checking the ERR LED)

9.3 Troubleshooting using the engineering tool

Check the error or history using the engineering tool, and identify the error cause. More detailed information on the error as well as the error cause and action to be taken can be checked by using the engineering tool.

The engineering tool has the following functions for troubleshooting.

Function	Description
Module Diagnostics (CPU Diagnostics)	This function diagnoses the module. (The current error and its details can be checked.)

For details on each function, refer to the following.

 GX Works3 Operating Manual

Module Diagnostics (CPU Diagnostics)

The Module Diagnostics (CPU Diagnostics) function is used to diagnose the CPU module and expansion adapter (check the error being generated and its detailed information).

Information required for troubleshooting, such as the current error, details and cause of the error, and action to be taken, are displayed. The incorrect parameter setting and program error location can also be identified by selecting the error and clicking the [Error Jump] button. On the [Module Information List] tab, the LED status and the switch status of the target module can be checked.

 [Diagnostics] ⇒ [Module Diagnostics (CPU Diagnostics)]

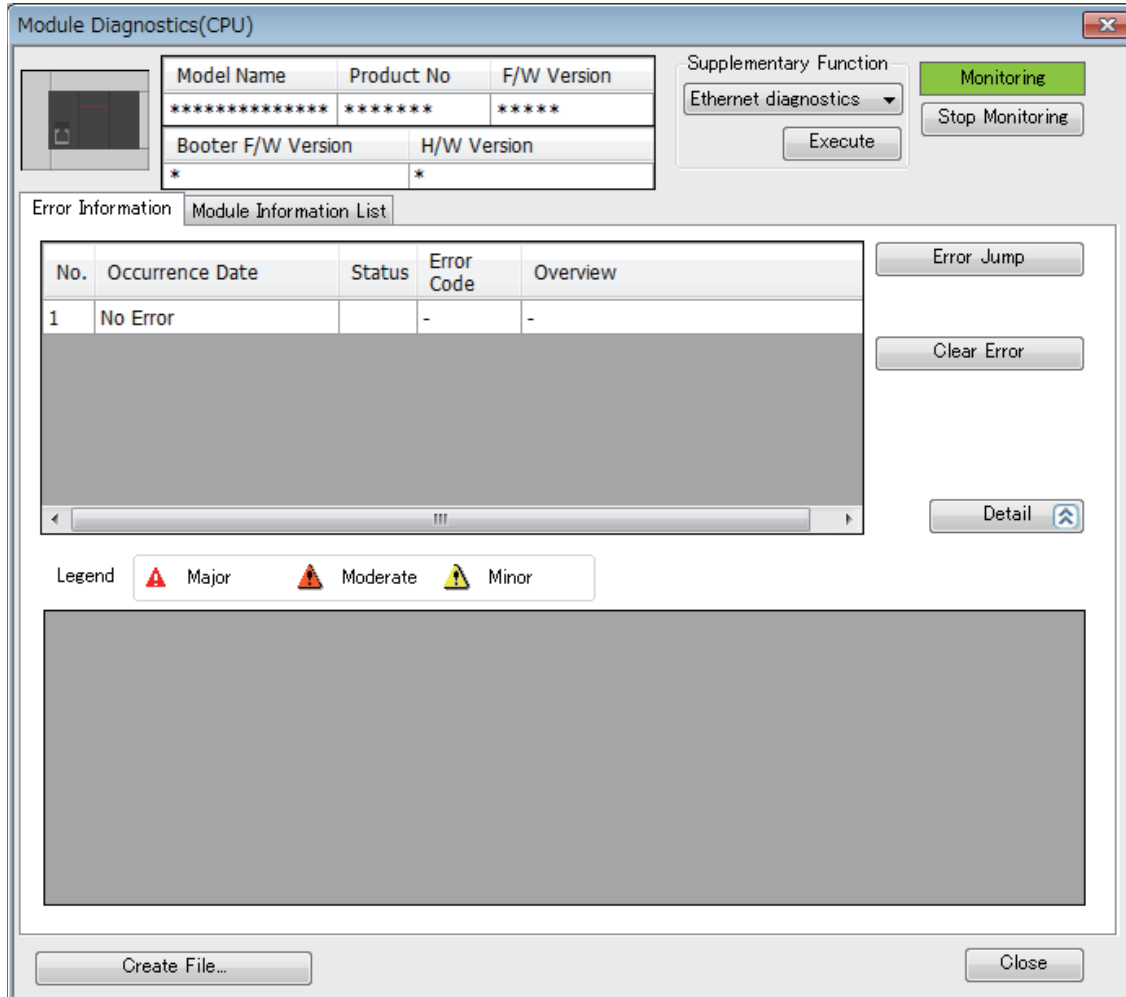

9.4 Error Status and Operations on Occurrence of an Error

When an error occurs, the CPU module performs preconfigured actions depending on the status of the error.

Error status

Errors are classified into the following three types according to the urgency of the errors.

Error status	Program execution status	Description	Required action
Major error	Stop	The module is unable to continue its operation due to a hardware issue.	Perform troubleshooting. If the error still persists, consult your local Mitsubishi Electric representative.
Moderate error	Stop	The module is unable to carry out programs or continue the data communication with stations on the network due to improper program or parameter settings and temporary noise.	To resume the execution of the program or the data communication with the stations on the network, use the engineering tool to identify the cause of the error and take corrective actions.
Minor error	Continue	The module has detected a minor error or alarm. However, the execution of the program and the data communication with the stations on the network are continues.	Check the details of the error with the engineering tool. If necessary, take corrective actions for the error.

Operation at the occurrence of an error

Errors are classified into stop errors and continuable errors.

■ Stop error

When a stop error occurs, the CPU module stops operation and enters the STOP status.

For details of parameters, refer to  MELSEC iQ-F FX5 User's Manual (Application).

■ Continuable error

When a continuable error occurs, the CPU module will keep the operation status and carry out operations.

Only continuable errors can be canceled. When a continuable error is canceled and the CPU module is restored, the CPU module returns to the status before the occurrence of the error. Continuable errors can be canceled by either of the following methods.

- Using engineering tools
- Using special relays (SM) ( Page 105 Canceling Errors)

Operation settings of the CPU module on occurrence of an intelligent function module error

The operation of the CPU module on occurrence of an intelligent function module error can be set with an engineering tool.

Configure the settings with [I/O Assignment Setting] in the system parameters.

9.5 Backing Up the Data

Saving the following information immediately after the occurrence of an error helps analyzing the cause of the error.

- Parameters, programs, and device memory
- Error histories

Backing up parameters, programs, and device memory

The procedure for backing up parameters, programs, and device memory by using an engineering tool is explained below.

 [Online] ⇒ [Read from PLC]

1. Check the parameters, programs, and device memory to back up.
2. Click the [Execute] button to read the data.

Backing up devices and buffer memory

The procedure for backing up devices and buffer memory using the engineering tool is explained below.

 [Online] ⇒ [Read from PLC]

1. Click the "Device Memory" check box.
2. Click [Detail].
3. Input character strings in "Device Data Name" and select the devices to back up.
4. Select the "Buffer Memory Intelligent Module No." and input module number.
5. Click [OK], and then click [Execute] to read the data from the PLC.

9.6 Canceling Errors

Only continuable errors can be canceled.

If an error is canceled and the CPU module is recovered, the status of SM, SD, or LEDs returns to the status before the occurrence of the error. After an error is canceled and when the same error occurs again, this error is recorded again in the error history.

When all errors are cancelled at once, annunciators will also be cleared. To clear annunciators individually, use the RST instruction. Continuable errors can be canceled by the following method.

Using special relays (SM)

Turning on and off SM50, all errors will be canceled.

9.7 Troubleshooting for Each Symptom

When the CPU module does not operate properly, check an appropriate item from the following and perform troubleshooting.

I/O operation (CPU module, I/O module)



Output does not turn on

Item to check	Action
Check for errors with external wiring.	Connect the external wiring properly.
Stop the PLC, and forcibly turn on or off the inoperable output with a peripheral device or an engineering tool.	<p>■When the output operates The output may be turned off unintentionally in the program. Review user program (Duplicate coils or RST instructions).</p> <p>■When the output does not operate Check the configuration of the connected devices and the connection of the extension cables. If the configuration of the external wiring and connected devices and the connection of the extension cables are acceptable, there may be a hardware issue. Consult your local Mitsubishi Electric representative.</p>

Output does not turn off

Item to check	Action
Check for errors with external wiring.	Connect the external wiring properly.
Stop the PLC and check that the output turns off.	<p>■When the output turns off The output may be turned on unintentionally in the program. Review user program (Duplicate coils or RST instructions).</p> <p>■When the output does not turn off There may be a hardware issue. Consult your local Mitsubishi Electric representative.</p>

Input does not turn on

Item to check	Action
<p>■FX5UC-32MT/D Remove the external wiring, and short-circuit the COM terminal and the input terminal. Check that the input turns on with LEDs and peripheral devices.</p>	<p>■When the input turns on Check that the input device does not have a built-in diode or parallel resistance. If so, refer to  Page 61 Precautions for connecting input devices.</p> <p>■When the input does not turn on Remove the external wiring, and measure the voltage between the COM terminal and the input terminal with a tester to check that the voltage is 24 V DC. When the input voltage is lower than 20.4 V DC, check that the PLC power supply voltage is "24 V DC +20%, -15%". Check the configuration of the external wiring and connected devices and the connection of the extension cables.</p>
<p>■FX5UC-32MT/DSS Remove the external wiring, and apply 24 V DC voltage between the COM□ terminal and the input terminal. Check that the input turns on with LEDs and peripheral devices.</p>	<p>■When the input turns on Check that the input device does not have a built-in diode or parallel resistance. If so, refer to  Page 61 Precautions for connecting input devices.</p> <p>■When the input does not turn on Check that the voltage between the COM□ terminal and the input terminal is approx. 24 V DC with a tester. When the input voltage is lower than 20.4 V DC, check that the external power supply voltage is "24 V DC +20%, -15%". Check the configuration of the external wiring and connected devices and the connection of the extension cables.</p>

Input does not turn off

Item to check	Action
Check that there is no leakage current from input devices.	If the leakage current is 1.5 mA or more, connect a bleeder resistance. ( Page 61 Precautions for connecting input devices)

PLC write, PLC read

PLC write cannot be performed

If data cannot be written to the CPU module from the engineering tool, check the following items.

Item to check	Action
Check if a password is not registered.	Authenticate a password using the engineering tool.
When an SD memory card is the write destination, check that the write protection is not applied to the card.	Remove the write protection from the SD memory card.  Page 123 SD Memory Card
When an SD memory card is the write destination, check that the card is formatted.	Format the SD memory card.
Check that the size of the write data does not exceed the memory capacity.	<ul style="list-style-type: none"> • Ensure sufficient empty capacity. • Clear the memory to which the data is to be written.

If writing still cannot be performed even after the items shown above are checked, there may be a hardware issue. Consult your local Mitsubishi Electric representative.

Reading from the PLC cannot be performed

If data cannot be read from the CPU module to the engineering tool, check the specification of the target memory to be read. Check the memory and reset the CPU module. Then try PLC read again.

If reading still cannot be performed, there may be a hardware issue. Consult your local Mitsubishi Electric representative.

The program is unintentionally overwritten

The boot operation may be being performed. Read the parameters and review the boot file settings with the engineering tool. If the boot operation is not being performed, there may be a hardware issue. Consult your local Mitsubishi Electric representative.

For details on the boot operation, refer to  MELSEC iQ-F FX5 User's Manual (Application).

Boot operation

Boot operation cannot be performed from the SD memory card

Item to check	Action
Check for errors in the CPU module.	Remove the cause of the error.
Check that the file is set in the boot file settings of the parameters.	Set the file in the parameters.
Check that the file is set in the program file settings of the parameters.	
Check that the file to run is stored in the SD memory card.	Store the file to run.

If the boot operation cannot be performed even after the items shown above are checked, there may be a hardware issue. Consult your local Mitsubishi Electric representative.

APPENDIX

Appendix 1 How to Check the Date of Manufacture

Check the date of manufacture of the product as follows.

- Nameplate
- Module front surface (CPU module only)

Checking the nameplate

The date of manufacture of the product can be checked from the manufacturer's serial number "S/N" indicated on the nameplate of the product.. (For details of the battery, refer to  Page 99 Reading the date of manufacture.)

Ex.

CPU module

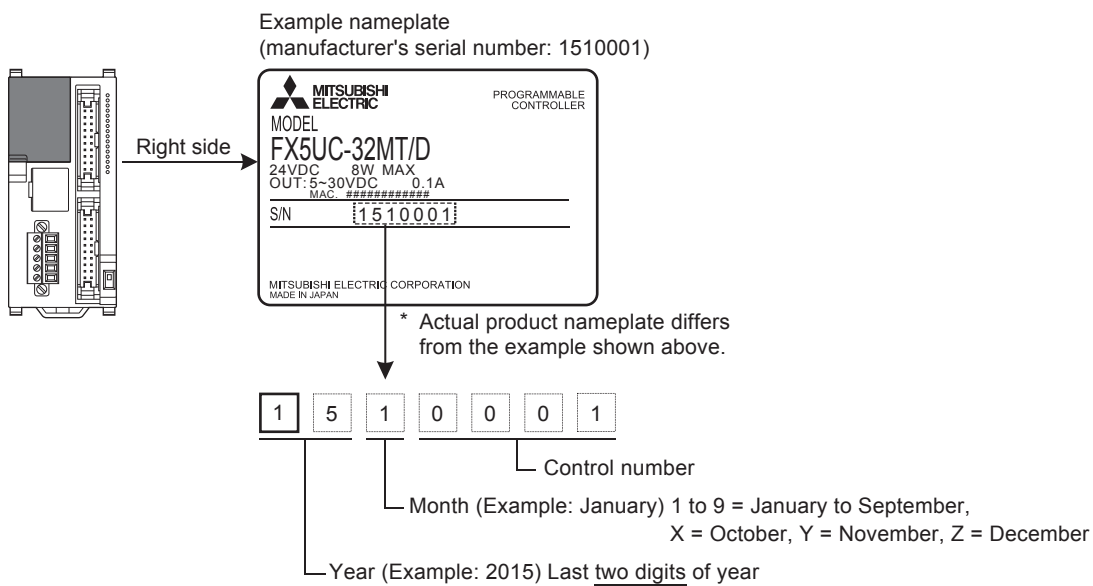

Check on the module front surface

The year and month of production of the product can be checked from the manufacturer's serial number LOT on the front (at the bottom) of the CPU module.

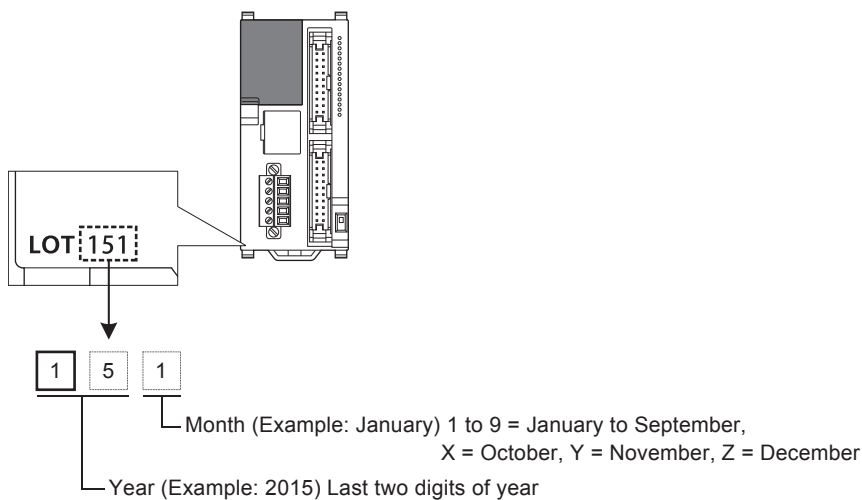

Appendix 2 Standards

Certification of UL, cUL standards

FX5UC CPU modules supports UL (UL, cUL) standards.
 For models that support UL standards, refer to the following.
 UL site <http://site.ul.com>
 UL, cUL file number: E95239

Compliance with EC directive (CE Marking)

This note does not guarantee that an entire machine produced in accordance with the contents of this note will comply with the following standards.

Compliance to EMC directive and LVD directive of the entire mechanical module should be checked by the user/ manufacturer. For more details please contact to the local Mitsubishi Electric sales site.

Requirement for compliance with EMC directive

The following products have shown compliance through direct testing (of the identified standards below) and design analysis (through the creation of a technical construction file) to the European Directive for Electromagnetic Compatibility (2004/108/ EC) when used as directed by the appropriate documentation.

Caution

- This product is designed for use in general industrial applications.
- The manufacturer, manufacturing location, and authorized representative in EU are as follows.

Manufacturer: Mitsubishi Electric Corporation
 Address: 2-7-3 Marunouchi, Chiyoda-ku, Tokyo, 100-8310 Japan

Manufacturing location: Mitsubishi Electric Corporation Himeji Works
 Address: 840 Chiyoda-machi, Himeji, Hyogo, 670-8677 Japan

Authorized representative in EU: Mitsubishi Electric Europe B.V.
 Address: Gothaer Str. 8, 40880 Ratingen, Germany

Product compatibility

Type: Programmable controller (open type equipment)

Models: FX5 manufactured

from October 1st, 2014	FX5-8EX/ES	FX5-8EYR/ES	FX5-8EYT/ES	FX5-8EYT/ESS
	FX5-16EX/ES	FX5-16EYR/ES	FX5-16EYT/ES	FX5-16EYT/ESS
	FX5-232ADP	FX5-485ADP	FX5-CNV-BUS	
from January 1st, 2015	FX5UC-32MT/D	FX5UC-32MT/DSS		
	FX5-C32EX/D	FX5-C32EYT/D	FX5-C32ET/D	
	FX5-C32EX/DS	FX5-C32EYT/DSS	FX5-C32ET/DSS	
	FX5-4AD-ADP	FX5-4DA-ADP	FX5-CNV-BUSC	FX5-CNV-IFC

Electromagnetic compatibility (EMC) directive	Remarks
EN61131-2:2007 Programmable controllers - Equipment requirements and tests	Compliance with all relevant aspects of the standard. EMI <ul style="list-style-type: none"> • Radiated emission • Conducted emission EMS <ul style="list-style-type: none"> • Radiated electromagnetic field • Fast transient burst • Electrostatic discharge • High-energy surge • Voltage drops and interruptions • Conducted RF • Power frequency magnetic field

Requirement for Compliance with LVD directive

The following products have shown compliance through direct testing (of the identified standards below) and design analysis (through the creation of a technical construction file) to the European Directive for Low Voltage (2006/95/EC) when used as directed by the appropriate documentation.

Type: Programmable controller (open type equipment)

Models: FX5 manufactured

from October 1st, 2014

FX5-8EYR/ES

FX5-16EYR/ES

Electromagnetic compatibility (EMC) directive	Remarks
EN61131-2:2007 Programmable controllers - Equipment requirements and tests	The equipment has been assessed as a component for fitting in a suitable enclosure which meets the requirements of EN61131-2:2007.

Caution for compliance with EC Directive

Installation in enclosure

FX5UC CPU modules are open-type devices that must be installed and used within shielded conductive control boxes.

Please use the PLCs while installed in conductive shielded control boxes. Please secure the control box lid to the control box (for conduction). Installation within a control box greatly improves the safety of the system and aids in shielding noise from the PLC.

Caution for when analog products are used

It is recommended to perform the following when precision of measuring and control is required.

As analog devices are sensitive by nature, their use should be considered carefully. For users of proprietary cables (integral with sensors or actuators), these users should follow those manufacturers' installation requirements.

Mitsubishi Electric recommends that shielded cables be used. If no other EMC protection is provided, users may experience temporary loss of accuracy between +10%/-10% in very heavy industrial areas.

However, Mitsubishi Electric suggests that if adequate EMC precautions are followed with general good EMC practice for the user's complete control system, users should expect normal errors as specified in this manual.

- Sensitive analog cables should not be laid in the same trunking or cable conduit as high voltage cabling. Where possible, users should run analog cables separately.
- Good cable shielding should be used. When terminating the shield at Earth - ensure that no earth loops are accidentally created.
- When reading analog values, EMC induced errors can be smoothed out by averaging the readings. This can be achieved either through functions on the analog special adapters/blocks or through a user's program in the FX5UC CPU module .

Perform the following when using the analog expansion adapter:

- Installation in Enclosure

Programmable controllers are open-type devices that must be installed and used within conductive control cabinets.

Please use the programmable controller while installed within a conductive shielded control cabinet. Installation within a control cabinet greatly affects the safety of the system and aids in shielding noise from the programmable controller.

- Control cabinet
 - The control cabinet must be conductive.
 - Ground the control cabinet with the thickest possible grounding cable.
 - To ensure that there is electric contact between the control cabinet and its door, connect the cabinet and its doors with thick wires.
 - In order to suppress the leakage of radio waves, the control cabinet structure must have minimal openings. Also, wrap the cable holes with a shielding cover or other shielding devices.
 - The gap between the control cabinet and its door must be as small as possible by attaching EMI gaskets between them.

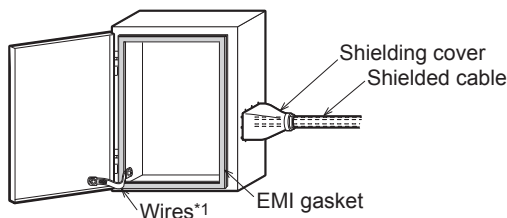

*1 These wires are used to improve the conductivity between the door and control cabinet.

- Cables
 - Make sure to use shielded cables as cables pulled out of the control cabinet.
 - Connect the shield such as shielded cables and shielding covers to the grounded control cabinet.
- It is possible that the accuracy temporarily fluctuates within $\pm 10\%$.

Perform the following when using the FX5-4AD-ADP:

- Set the number of times of winding to “2 turns” within approximately 200 mm (7.87”) from terminal block of the analog cable on the FX5-4AD-ADP side, and attach a ferrite core. (Ferrite core used in our test: E04SR401938 manufactured by SEIWA ELECTRIC MFG. CO., LTD.)

Perform the following when using the FX5-4DA-ADP:

- Set the number of times of winding to “2 turns” within approximately 200 mm (7.87”) from the connectors of the power cable on the FX5-4DA-ADP side, and attach a ferrite core. (Ferrite core used in our test: E04SR401938 manufactured by SEIWA ELECTRIC MFG. CO., LTD.)
- The FX5-4DA-ADP requires that the cable used for power supply is 30 m (9’85”) or less.

Caution for when the built-in Ethernet port is used

- Use a shielded twisted pair cable for the 10BASE-T or 100BASE-TX cable. Strip a part of the jacket of a shielded twisted pair cable as shown below, and ground as much of the exposed shield as possible to both sides of the cables.
- Connect a ferrite core to both ends of the cable. (Ferrite core used in tests by Mitsubishi: ZCAT2035-0930A manufactured by TDK Co.)

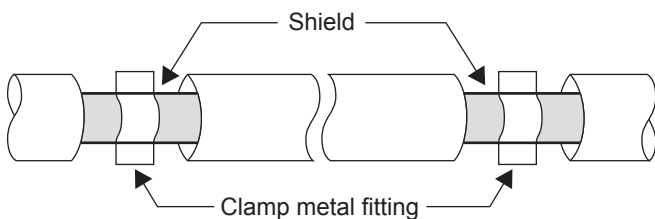

Appendix 3 I/O Module

Product configuration

There are various types of I/O modules. They differ in supply voltage, number of input/output points, input form, output form, and connection type.

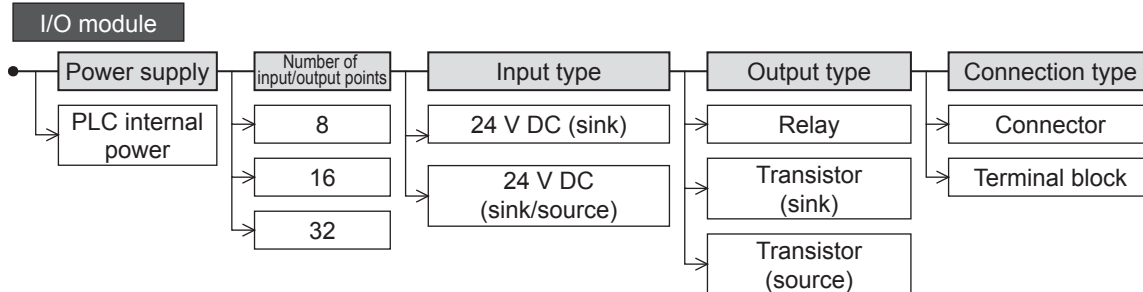

Product list

Input module

Sink : Sink, Source : Source

■ Extension connector type

Model	Input			Output			Connection type
	Type	No. of points	Common wiring system	Type	No. of points	Common wiring system	
■ Input extension/sink input only							
FX5-C32EX/D	24 V DC	32	<input type="checkbox"/> Sink	—	—	—	Connector
■ Input extension/sink and source input type							
FX5-C32EX/DS	24 V DC	32	<input type="checkbox"/> Sink <input checked="" type="checkbox"/> Source	—	—	—	Connector

■ Extension cable type

Model	Input			Output			Connection type
	Type	No. of points	Common wiring system	Type	No. of points	Common wiring system	
■ Input extension/sink and source input type							
FX5-8EX/ES	24 V DC	8	<input type="checkbox"/> Sink <input checked="" type="checkbox"/> Source	—	—	—	Terminal block
FX5-16EX/ES	24 V DC	16	<input type="checkbox"/> Sink <input checked="" type="checkbox"/> Source	—	—	—	Terminal block

Output module

Sink : Sink, Source : Source

■ Extension connector type

Model	Input			Output			Connection type
	Type	No. of points	Common wiring system	Type	No. of points	Common wiring system	
■ Output extension/sink output only							
FX5-C32EYT/D	—	—	—	Transistor	32	<input type="checkbox"/> Sink	Connector
■ Output extension/source output only							
FX5-C32EYT/DSS	—	—	—	Transistor	32	<input checked="" type="checkbox"/> Source	Connector

Extension cable type

Model	Input			Output			Connection type
	Type	No. of points	Common wiring system	Type	No. of points	Common wiring system	
■Output extension/relay output type							
FX5-8EYR/ES	—	—	—	Relay	8	—	Terminal block
FX5-16EYR/ES	—	—	—	Relay	16	—	Terminal block
■Output extension/sink output only							
FX5-8EYT/ES	—	—	—	Transistor	8	Sink	Terminal block
FX5-16EYT/ES	—	—	—	Transistor	16	Sink	Terminal block
■Output extension/source output only							
FX5-8EYT/ESS	—	—	—	Transistor	8	Source	Terminal block
FX5-16EYT/ESS	—	—	—	Transistor	16	Source	Terminal block

Input/output module

Sink : Sink, Source : Source

Model	Input			Output			Connection type
	Type	No. of points	Common wiring system	Type	No. of points	Common wiring system	
■Input/output extension/sink input/output only							
FX5-C32ET/D	24 V DC	16	Sink	Transistor	16	Sink	Connector
■Input/output extension/sink and source input/source output only							
FX5-C32ET/DSS	24 V DC	16	Sink Source	Transistor	16	Source	Connector

Specifications

The general specifications are the same as those for the CPU module. (Page 17 Generic Specifications)

Power Supply Specifications

Input module

Item		Specifications
Voltage rating	FX5-C32EX/□	5 V DC (supplied from PLC)
	FX5-8EX/ES, FX5-16EX/ES	24 V DC (supplied from external power supply) 5 V DC (supplied from PLC)
Current consumption (5 V DC)	FX5-C32EX/□	120 mA
	FX5-8EX/ES	75 mA
	FX5-16EX/ES	100 mA
Current consumption (24 V DC)	FX5-8EX/ES	(50 mA) ^{*1}
	FX5-16EX/ES	(85 mA) ^{*1}

*1 Since external power supply is used for input circuit in FX5UC CPU module systems, power supply from CPU module is not included.

Output module

Item		Specifications
Voltage rating		24 V DC (supplied from PLC) 5 V DC (supplied from PLC)
Current consumption (5 V DC)	FX5-C32EY□	120 mA
	FX5-8EY□	75 mA
	FX5-16EY□	100 mA
Current consumption (24 V DC)	FX5-C32EY□	200 mA
	FX5-8EY□	75 mA
	FX5-16EY□	125 mA

■ Input/output module

Item		Specifications
Voltage rating	Input connector	5 V DC (supplied from PLC)
	Output connector	24 V DC (supplied from PLC) 5 V DC (supplied from PLC)
Current consumption (5 V DC)		120 mA
Current consumption (24 V DC)		100 mA

Exterior color, weight, accessories

■ Input module, Output module

Item		Specifications
Exterior color		Munsell 0.6B7.6/0.2
Mass (weight)	FX5-C32EX/□ FX5-C32EYT/□	Approx. 0.15 kg (0.33 lbs)
	FX5-8E□	Approx. 0.2 kg (0.44 lbs)
	FX5-16E□	Approx. 0.25 kg (0.55 lbs)
Accessories	FX5-C32EX/D	FX2NC-10BPCB1
	FX5-8E□	Dust proof protection sheet
	FX5-16E□	

■ Input/output module

Item		Specifications
Exterior color		Munsell 0.6B7.6/0.2
Mass (weight)		Approx. 0.15 kg (0.33 lbs)
Accessories	FX5-C32ET/D	FX2NC-10BPCB1

Input specifications

There is the simultaneous ON ratio of available PLC inputs or outputs with respect to the ambient temperature. For details, refer to  Page 20 Input/Output Derating Curve.

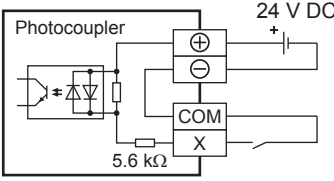
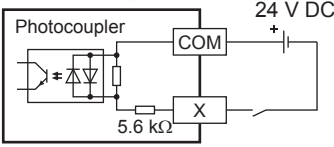
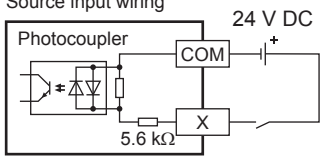
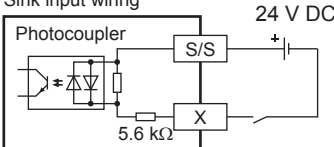
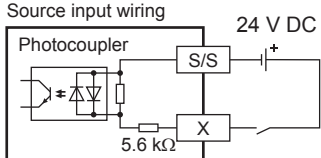
Item		Specifications
No. of input points	FX5-C32EX□	32 points
	FX5-C32ET□	16 points
	FX5-8EX/ES	8 points
	FX5-16EX/ES	16 points
Connection type	FX5-C32EX□	Connector
	FX5-C32ET□	
	FX5-8EX/ES	Terminal block (M3 screws)
	FX5-16EX/ES	
Input type	FX5-C32EX/D, FX5-C32ET/D	Sink
	FX5-C32EX/DS, FX5-C32ET/DSS, FX5-8EX/ES, FX5-16EX/ES	Sink/source
Input signal voltage		24 V DC +20%, -15%
Input signal current		4 mA/24 V DC
Input impedance		5.6 kΩ
Input sensitivity current	ON	3.0 mA or more
	OFF	1.5 mA or less
Input response time		ON: 50 μs or less OFF: 150 μs or less
Input signal format		No-voltage contact input Sink: NPN open collector transistor Source: PNP open collector transistor
Input circuit insulation		Photo-coupler insulation
Indication of input operation		LED is lit when input is on
Input circuit configuration	FX5-C32EX/D, FX5-C32ET/D	
	FX5-C32EX/DS, FX5-C32ET/DSS	<div style="display: flex; justify-content: space-around;"> <div style="text-align: center;"> <p>Sink input wiring</p>  </div> <div style="text-align: center;"> <p>Source input wiring</p>  </div> </div>
	FX5-8EX/ES, FX5-16EX/ES	<div style="display: flex; justify-content: space-around;"> <div style="text-align: center;"> <p>Sink input wiring</p>  </div> <div style="text-align: center;"> <p>Source input wiring</p>  </div> </div>

Output specifications

There is the simultaneous ON ratio of available PLC inputs or outputs with respect to the ambient temperature. For details, refer to  Page 20 Input/Output Derating Curve.

■ Transistor output (sink output)

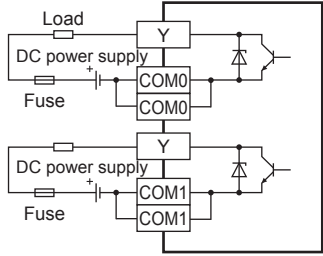
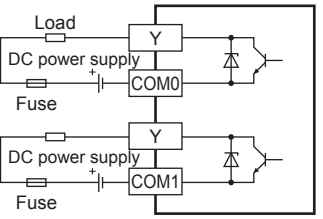
Item		Specifications	
No. of output points	FX5-C32EYT/D	32 points	
	FX5-C32ET/D	16 points	
	FX5-8EYT/ES	8 points	
	FX5-16EYT/ES	16 points	
Connection type	FX5-C32EYT/D	Connector	
	FX5-C32ET/D		
	FX5-8EYT/ES	Terminal block (M3 screws)	
	FX5-16EYT/ES		
Output type	Transistor/sink output		
External power supply	5 to 30 V DC		
Output circuit insulation	Photo-coupler insulation		
Indication of output operation	LED is lit when output is on (Display of smaller and larger numbers can be switched by setting the DISP switch in F or L.)		
Max. load	FX5-C32EYT/D	0.1 A/point	
	FX5-C32ET/D	The total load current of resistance loads per common terminal should be the following value. • 8 output points/common terminal: 0.8 A or less	
	FX5-8EYT/ES	0.5 A/point	
	FX5-16EYT/ES	The total load current of resistance loads per common terminal should be the following value. • 4 output points/common terminal: 0.8 A or less • 8 output points/common terminal: 1.6 A or less	
Open circuit leakage current	0.1 mA/30 V DC		
Min. load	—		
Response time	OFF→ON	FX5-C32EYT/D, FX5-C32ET/D	0.2 ms or less/100 mA (at 24 V DC)
		FX5-8EYT/ES, FX5-16EYT/ES	0.2 ms or less/200 mA (at 24 V DC)
	ON→OFF	FX5-C32EYT/D, FX5-C32ET/D	0.2 ms or less/100 mA (at 24 V DC)
		FX5-8EYT/ES, FX5-16EYT/ES	0.2 ms or less/200 mA (at 24 V DC)
Voltage drop when ON	1.5 V or less		
Output circuit configuration	FX5-C32EYT/D, FX5-C32ET/D		
	FX5-8EYT/ES, FX5-16EYT/ES		

■ Transistor output (source output)

Item		Specifications	
No. of output points	FX5-C32EYT/DSS	32 points	
	FX5-C32ET/DSS	16 points	
	FX5-8EYT/ESS	8 points	
	FX5-16EYT/ESS	16 points	
Connection type	FX5-C32EYT/DSS	Connector	
	FX5-C32ET/DSS		
	FX5-8EYT/ESS	Terminal block (M3 screws)	
	FX5-16EYT/ESS		
Output type	Transistor/source output		
External power supply	5 to 30 V DC		
Output circuit insulation	Photo-coupler insulation		
Indication of output operation	LED is lit when output is on (Display of smaller and larger numbers can be switched by setting the DISP switch in F or L.)		
Max. load	FX5-C32EYT/DSS	0.1 A/point	
	FX5-C32ET/DSS	The total load current of resistance loads per common terminal should be the following value. • 8 output points/common terminal: 0.8 A or less	
	FX5-8EYT/ESS	0.5 A/point	
	FX5-16EYT/ESS	The total load current of resistance loads per common terminal should be the following value. • 4 output points/common terminal: 0.8 A or less • 8 output points/common terminal: 1.6 A or less	
Open circuit leakage current	0.1 mA/30 V DC		
Min. load	—		
Response time	OFF→ON	FX5-C32EYT/DSS, FX5-C32ET/DSS	0.2 ms or less/100 mA (at 24 V DC)
		FX5-8EYT/ESS, FX5-16EYT/ESS	0.2 ms or less/200 mA (at 24 V DC)
	ON→OFF	FX5-C32EYT/DSS, FX5-C32ET/DSS	0.2 ms or less/100 mA (at 24 V DC)
		FX5-8EYT/ESS, FX5-16EYT/ESS	0.2 ms or less/200 mA (at 24 V DC)
Voltage drop when ON	1.5 V or less		
Output circuit configuration	FX5-C32EYT/DSS, FX5-C32ET/DSS		
	FX5-8EYT/ESS, FX5-16EYT/ESS		

■ Relay output

Item		Specifications
No. of output points	FX5-8EYR/ES	8 points
	FX5-16EYR/ES	16 points
Connection type		Terminal block (M3 screws)
Output type		Relay
External power supply		30 V DC or less 240 V AC or less (250 V AC or less when the module does not comply with CE, UL, or cUL standards)
Output circuit insulation		Mechanical insulation
Indication of output operation		LED is lit when output is on
Max. load		2 A/point The total load current of resistance loads per common terminal should be the following value. • 4 output points/common terminal: 8 A or less • 8 output points/common terminal: 8 A or less
Open circuit leakage current		—
Min. load		5 V DC, 2 mA (reference values)
Response time	OFF→ON	Approx. 10 ms
	ON→OFF	Approx. 10 ms
Output circuit configuration		

External dimensions and component names

Input module, Output module

■ Extension connector type

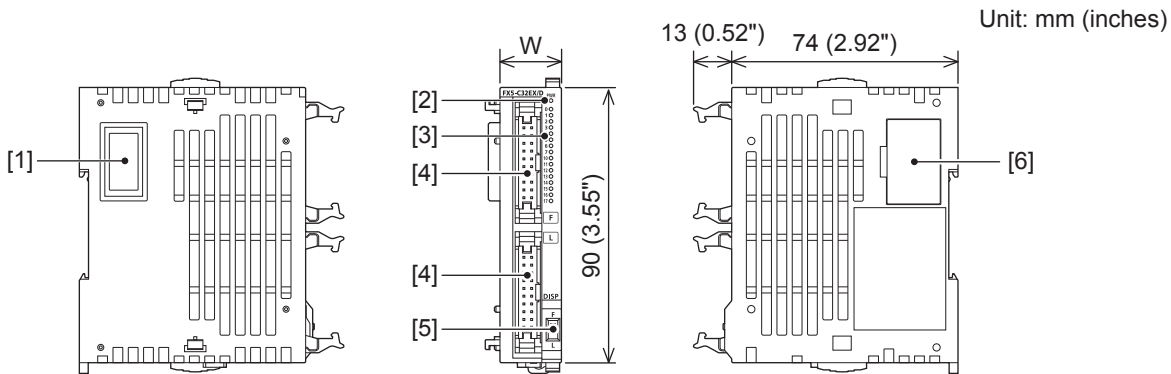

External dimensions

Model	W: mm (inches)
FX5-C32EX/D, FX5-C32EX/DS	20.1 (0.8")
FX5-C32EYT/D, FX5-C32EYT/DSS	

Part names

No.	Name	Description
[1]	Extension connector	Connector connected to extend modules
[2]	PWR LED	Indicates whether the input modules/output modules is powered or not. Lit: Powered Off: Not powered or hardware error
[3]	I/O display LED	Lit when input or output is on.
[4]	I/O connectors	Connector for connecting input signal cables or output signal cables
[5]	DISP switch	Switches the display of smaller and larger numbers of the input display LED or output display LED. Smaller number: F Larger number: L
[6]	Extension connector	Connector for connecting the extension connector of an extension module

■ Extension cable type

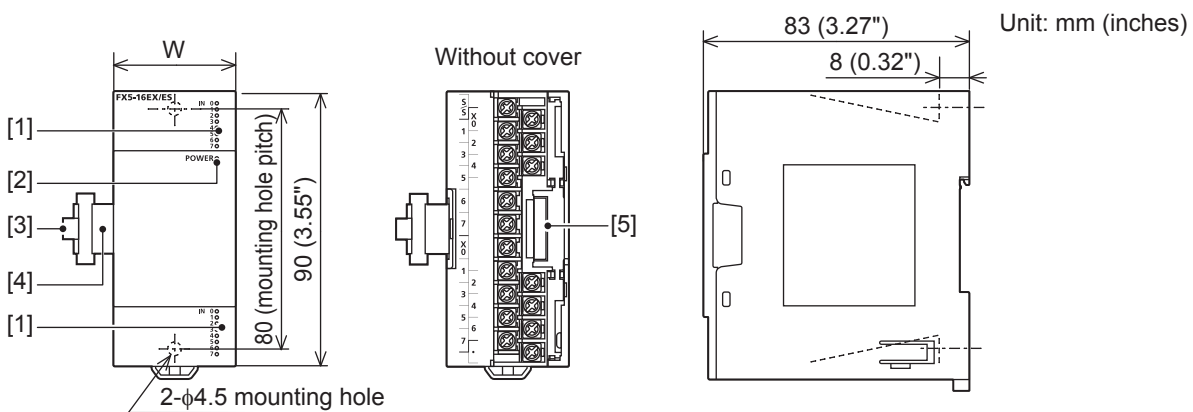

External dimensions

Model	W: mm (inches)
FX5-8EX/ES	40 (1.58")
FX5-8EYR/ES, FX5-8EYT/ES, FX5-8EYT/ESS	
FX5-16EX/ES	
FX5-16EYR/ES, FX5-16EYT/ES, FX5-16EYT/ESS	

Part names

No.	Name	Description
[1]	Input display LED, output display LED	Lit when input or output is on.
[2]	POWER LED	Indicates whether the input modules/output modules are powered or not. Lit: Powered Off: Not powered or hardware error
[3]	Pullout tab	Tab for pulling out an extension cable.
[4]	Extension cable	Cable connected to extend modules.
[5]	Extension connector	Connector for connecting the extension cable of an extension module

Input/output module

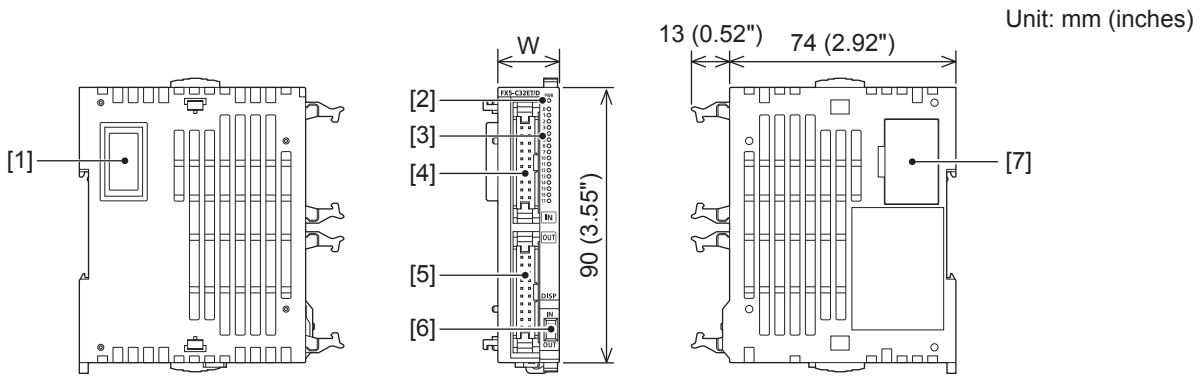

External dimensions

Model	W: mm (inches)
FX5-C32ET/D, FX5-C32ET/DSS	20.1 (0.8")

Part names

No.	Name	Description
[1]	Extension connector	Connector connected to extend modules
[2]	PWR LED	Indicates whether the input/output modules are powered or not. Lit: Powered Off: Not powered or hardware error
[3]	I/O display LED	Lit when input or output is on.
[4]	Input connector	Connector for connecting input signal cables.
[5]	Output connector	Connector for connecting output signal cables.
[6]	DISP switch	Switches input/output of the I/O display LED. Input: IN Output: OUT
[7]	Extension connector	Connector for connecting the extension connector of an extension module

Terminal layout

Extension connector type

FX5-C32EX/D

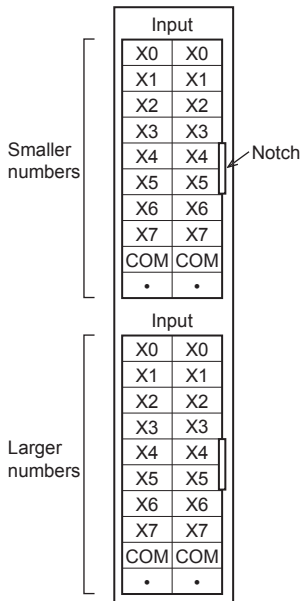

FX5-C32EYT/D

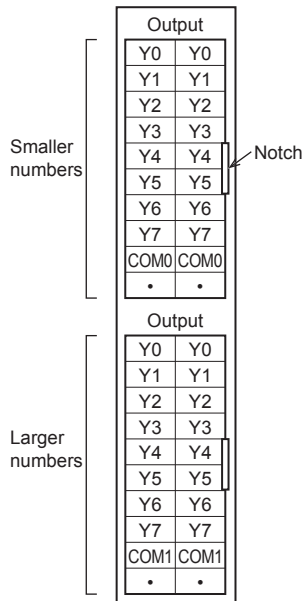

FX5-C32ET/D

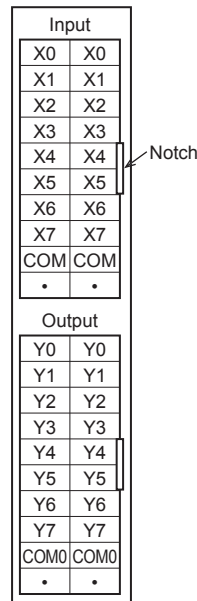

FX5-C32EX/DS

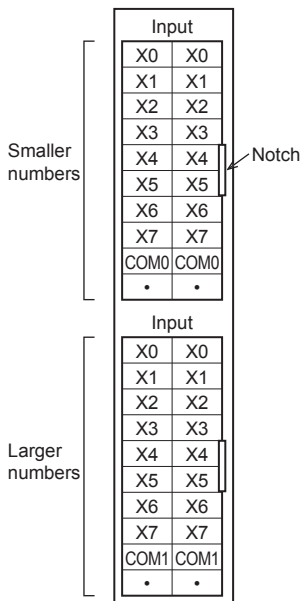

FX5-C32EYT/DS

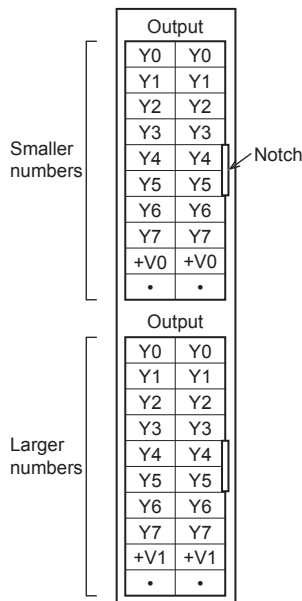

FX5-C32ET/DS

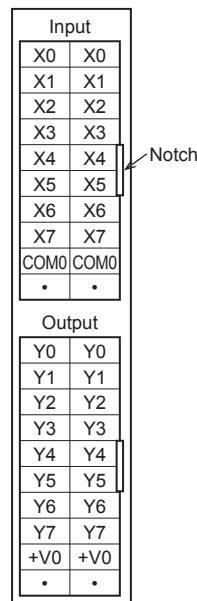

Extension cable type

FX5-8EX/ES



**FX5-8EYR/ES
FX5-8EYT/ES**

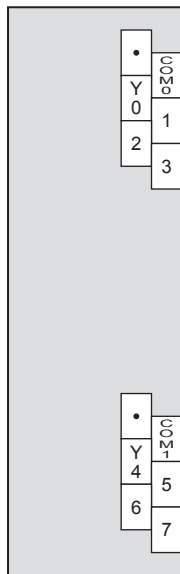

FX5-8EYT/ESS

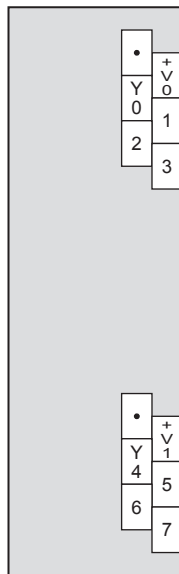

FX5-16EX/ES

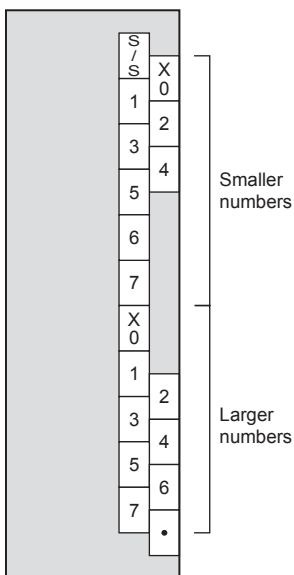

**FX5-16EYR/ES
FX5-16EYT/ES**

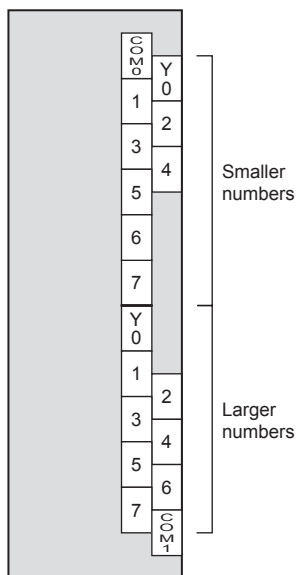

FX5-16EYT/ESS

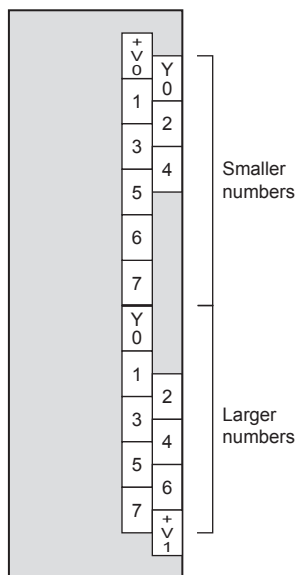

Appendix 4 SD Memory Card

Part names

An SD memory card is installed in the CPU module to operate the module based on the project data in the card.

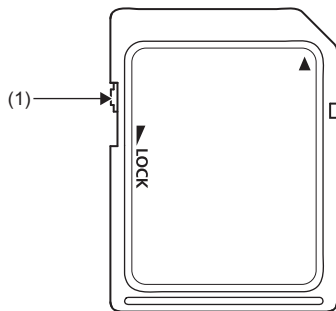

No.	Name	Description
(1)	Write protect switch	Setting the switch in the lock position prevents the data in the SD memory card from being deleted and overwritten.

Specifications

The following shows functional specifications of the SD memory card.

Item		NZ1MEM-2GBSD	NZ1MEM-4GBSD
Type		SD memory card	SDHC memory card
Capacity		2 Gbytes	4 Gbytes
Number of writes		60,000 times	100,000 times
External dimensions	Height	32 mm (1.25")	
	Width	24 mm (0.94")	
	Depth	2.1 mm (0.08")	
Mass (weight)		2 g	

Point

For L1MEM-2GBSD and L1MEM-4GBSD, refer to the following.
(QCPU User's Manual(Hardware Design, Maintenance and Inspection))

Handling of the SD memory card

- Operational compatibility of the SD memory cards manufactured by Mitsubishi (NZ1MEM-2GBSD and NZ1MEM-4GBSD) with MELSEC iQ-F series CPU modules has been checked. Use of SD memory card other than a Mitsubishi SD memory card may result in loss of the data stored in the SD memory card, or problems such as system stop.
- When mounted in the CPU module, SD memory cards manufactured by Mitsubishi are compliant with IEC61131-2.
- The SDHC memory card can be used only with devices with an SDHC logo or whose user's manual lists an SDHC logo. Note that SDHC cards cannot be used with devices that support only "SD" specifications.
- Turning off or resetting the CPU module or removing the SD memory card while the card is being accessed may corrupt the data in the SD memory card. Always turn off or reset the CPU module or remove the SD memory card after disabling access to the SD memory card. With SM606 (SD memory card forced disable instruction) and SM607 (SD memory card forced disable status flag), the SD memory card can be disabled and its usage status can be checked.
- It is recommended that important data be periodically backed up to CD, DVD, or other media.

Formatting

To use any SD memory card in the CPU module, the card must be formatted. In the initial state after purchase, the SD memory card is not formatted. Insert the SD memory card to a CPU module and format the SD memory card using the engineering tool before use. Do not format the SD memory card using the personal computer. (GX Works3 Operating Manual)

Insertion and removal of the SD memory card

The following explains insertion and removal of the SD memory card.

Insertion procedure

Mount the SD memory card. Pay attention to the direction of the card and follow the procedure below.

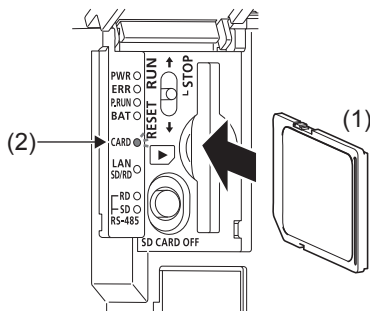

1. Insert the SD memory card (1) straight into the SD memory card slot. Make sure that the notch of the card is directed downward. After mounting, check that the card is mounted completely. If the card is mounted incompletely, malfunctions may occur because of poor contact.
2. The CARD LED (2) blinks until the SD memory card becomes available.
3. The CARD LED turns on when the SD memory card is available.
4. If the CARD LED does not turn on even though the SD memory card is mounted, make sure that SM606 (forcibly stop using SD memory card instruction) and SM607 (forcibly stop using SD memory card flag) are OFF by using engineering tools.

Removal procedure

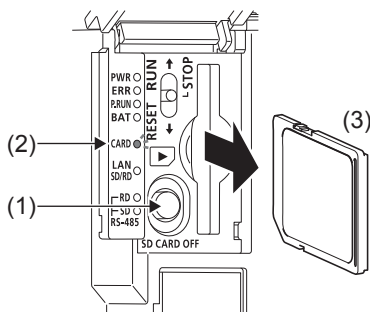

1. Press the SD memory card stop switch (1) for one second or more to stop access to the card. The CARD READY LED (2) blinks during the access stop operation, and then the LED is turned OFF when the operation is completed.
2. Insert the SD memory card (3) once, and then pull it straight.

Precautions

- When mounting or removing the SD memory card while the power is ON, follow the above-mentioned procedure. Otherwise, the data in the card may be broken.
- When removing the SD memory card which is being accessed by any function, the CARD LED is turned OFF after the access is completed. When the CARD LED is turned OFF depends on the accessing function.
- When SM605 (mount and remove memory card disabling flag) is ON, the CARD LED is not turned OFF even if the SD memory card stop switch is pressed. If the CARD LED is not turned OFF, turn ON SM606 (instruction of forcibly stop using SD memory card) so that the SD memory card cannot be used.

Appendix 5 Terminal Module

Product configuration

Terminal modules are used to convert connector-type I/O terminals into terminal blocks. By using terminal blocks (built-in element type) dedicated to input or output, capturing of AC input signals and format conversion into the relay/transistor/triac output can be performed.

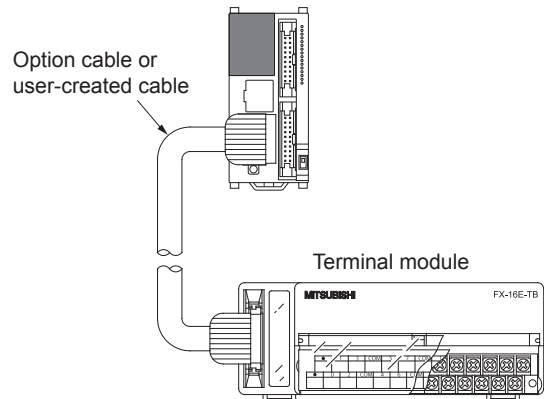

Product list

Sink input/sink output (transistor output)

Model	No. of input points	No. of output points	Function	Connection destination	Driving current
■Sink input/sink output (transistor output)					
FX-16E-TB	16 input points or 16 output points		Directly connected to I/O terminals of a PLC.	FX5UC-32MT/D, FX5-C32EX/D, FX5-C32EYT/D, FX5-C32ET/D	Refer to the following table.
FX-32E-TB	32 input points, 32 output points, or 16 input points and 16 output points				
FX-16EX-A1-TB	16	—	100 V AC input type	FX5UC-32MT/D, FX5-C32EX/D, FX5-C32ET/D	24 V DC 48 mA
FX-16EYR-TB	—	16	Relay output type	FX5UC-32MT/D, FX5-C32EYT/D, FX5-C32ET/D	24 V DC 80 mA
FX-16EYT-TB	—	16	Transistor output type (sink)		24 V DC 112 mA
FX-16EYS-TB	—	16	Triac output type		
■Sink and source common input/source output (transistor output)					
FX-16E-TB/UL	16 input points or 16 output points		Directly connected to I/O terminals of a PLC.	FX5UC-32MT/DSS, FX5-C32EX/DS, FX5-C32EYT/DSS, FX5-C32ET/DSS	Refer to the following table.
FX-32E-TB/UL	32 input points, 32 output points, or 16 input points and 16 output points				
FX-16EYR-ES-TB/UL	—	16	Relay output type	FX5UC-32MT/DSS, FX5-C32EYT/DSS, FX5-C32ET/DSS	24 V DC 80 mA
FX-16EYT-ES-TB/UL	—	16	Transistor output type (sink)		24 V DC 112 mA
FX-16EYT-ESS-TB/UL	—	16	Transistor output type (source)		
FX-16EYS-ES-TB/UL	—	16	Triac output type		

• The following table shows driving current of FX-16E-TB(/UL) and FX-32E-TB(/UL) that depends on the connection destination.

Connection destination	Power supply voltage	Current consumption
■Input connector		
FX5UC-32MT/D, FX5-C32EX/D, FX5-C32ET/D	Not required	
FX5UC-32MT/DSS, FX5-C32EX/DS, FX5-C32ET/DSS	24 V DC	112 mA/16 points
■Output connector		
FX5UC-32MT/D, FX5UC-32MT/DSS, FX5-C32EYT/D, FX5-C32EYT/DSS, FX5-C32ET/D, FX5-C32ET/DSS	The power supply appropriate to the connected load is required.	

Specifications

Exterior color, accessories

Item	Specifications
Exterior color	Munsell 0.08GY/7.64/0.81
Accessories	Input/output number label, terminal block layout card

Input specifications

■FX-16EX-A1-TB

Item	Specifications	
Input type	AC input	
Input signal voltage	100 to 120 V AC +10% -15% 50/60 Hz	
Input signal current	4.7 mA/100 V AC 50 Hz 6.2 mA/110 V AC 60 Hz	
Input impedance	Approx. 21 k Ω /50 Hz Approx. 18 k Ω /60 Hz	
Input sensitivity	ON	3.8 mA/80 V AC or more
	OFF	1.7 mA/30 V AC or less
Input response time ^{*1}	25 to 30 ms	
Input signal format	Voltage contact	
Input circuit insulation	Photo-coupler insulation	
Indication of input operation	No input LED (However, the 24 V power LED display exists.)	
Power consumption	1.2 W (48 mA 24 V DC)	
Input/output configuration circuit		
Unsupported applications	High-speed counter, input interruption, pulse catch, Speed Detection ((D)SPD) instruction, Input Matrix (MTR) instruction, Digital Switch (DSW) instruction, ABS Current Value Read (DBS) instruction, high-speed I/O function start/stop ((D)HIOEN) instruction	

*1 The response delay time of the CPU module is not included.

Output specifications

■ Relay output (FX-16EYR-TB, FX-16EYR-ES-TB/UL)

Item		Specifications	
Output type		Relay	
External voltage		250 V AC or less, 30 V DC or less	
Max. load	Resistance load	2 A/point	The total load current per common terminals (four points) should be 8 A or less.
	Inductive load	80 VA	
Min. load		5 V DC, 2 mA (reference values)	
Open circuit leakage current		—	
Response time		Approx. 10 ms	
ON voltage of output element		1.5 V	
Insulation of circuit		Mechanical insulation	
Indication of output operation		LED is lit when the power is supplied to relay coils.	
Power consumption		1.92 W (80 mA 24 V DC)	
Input/output configuration circuit	FX-16EYR-TB		
	FX-16EYR-ES-TB/UL		
Unsupported applications		Positioning, Pulse Y Output ((D)PLSY) instruction, Pulse Width Modulation ((D)PWM) instruction, ABS Current Value Read (DABS) instruction, Start/stop of high-speed I/O function ((D)HIOEN) instruction, Input Matrix (MTR) instruction, Digital Switch (DSW) instruction, Seven Segment With Latch (SEGL) instruction	

■ Transistor/sink output (FX-16EYT-TB, FX-16EYT-ES-TB/UL)

Item		Specifications	
Output type		Transistor/sink output	
External voltage		5 to 30 V DC	
Max. load	Resistance load	0.5 A/point	The total load current per common terminals (four points) should be 0.8 A or less.
	Inductive load	12 W/24 V DC	
Min. load		—	
Open circuit leakage current		0.1 mA/30 V DC	
Response time		OFF→ON	0.2 ms or less/24 V DC
		ON→OFF	1.5 ms or less/24 V DC
ON voltage of output element		1.5 V	
Insulation of circuit		Photo-coupler insulation	
Indication of output operation		LED is lit when the power is supplied to photo-couplers.	
Power consumption		2.7 W (112 mA 24 V DC)	
Input/output configuration circuit	FX-16EYT-TB		
	FX-16EYT-ES-TB/UL		
Unsupported applications		Positioning, Pulse Y Output ((D)PLSY) instruction, Pulse Width Modulation ((D)PWM) instruction, ABS Current Value Read (DABS) instruction, Start/stop of high-speed I/O function ((D)HIOEN) instruction, Input Matrix (MTR) instruction, Digital Switch (DSW) instruction, Seven Segment With Latch (SEGL) instruction	

■ Transistor/source output (FX-16EYT-ESS-TB/UL)

Item		Specifications	
Output type		Transistor/source output	
External voltage		5 to 30 V DC	
Max. load	Resistance load	0.5 A/point	The total load current per common terminals (four points) should be 0.8 A or less.
	Inductive load	12 W/24 V DC	
Min. load		—	
Open circuit leakage current		0.1 mA/30 V DC	
Response time		OFF→ON	0.2 ms or less/24 V DC
		ON→OFF	1.5 ms or less/24 V DC
ON voltage of output element		1.5 V	
Insulation of circuit		Photo-coupler insulation	
Indication of output operation		LED is lit when the power is supplied to photo-couplers.	
Power consumption		2.7 W (112 mA 24 V DC)	
Input/output configuration circuit			
Unsupported applications		Positioning, Pulse Y Output ((D)PLSY) instruction, Pulse Width Modulation ((D)PWM) instruction, ABS Current Value Read (DABS) instruction, Start/stop of high-speed I/O function ((D)HIOEN) instruction, Input Matrix (MTR) instruction, Digital Switch (DSW) instruction, Seven Segment With Latch (SEGL) instruction	

■ Triac output (FX-16EYS-TB, FX-16EYS-ES-TB/UL)

Item		Specifications	
Output type		Triac (SSR)	
External voltage		85 to 242 V AC	
Max. load	Resistance load	0.3 A/point	The total load current per common terminals (four points) should be 0.8 A or less.
	Inductive load	15 VA/100 V AC 36 VA/200 V AC	
Min. load		0.4 VA/100 V AC 1.6 VA/200 V AC	
Open circuit leakage current		1 mA/100 V AC 2 mA/200 V AC	
Response time		2 ms or less	
ON voltage of output element		—	
Insulation of circuit		Photo-coupler insulation	
Indication of output operation		LED is lit when the power is supplied to photo-thyristors.	
Power consumption		2.7 W (112 mA 24 V DC)	
Input/output configuration circuit	FX-16EYS-TB		
	FX-16EYS-ES-TB/UL		
Unsupported applications		Positioning, Pulse Y Output ((D)PLSY) instruction, Pulse Width Modulation ((D)PWM) instruction, ABS Current Value Read (DABS) instruction, Start/stop of high-speed I/O function ((D)HIOEN) instruction, Input Matrix (MTR) instruction, Digital Switch (DSW) instruction, Seven Segment With Latch (SEGL) instruction	

External dimensions and component names

• FX-16E-TB, FX-16E-TB/UL

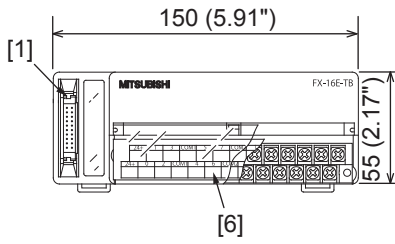

• FX-32E-TB, FX-32E-TB/UL

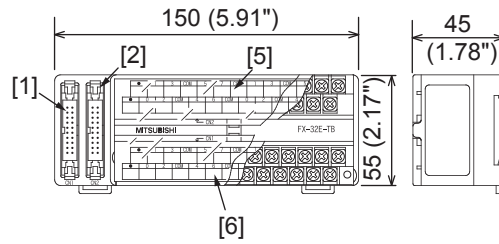

• FX-16EX-A1-TB

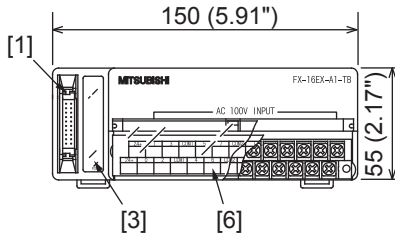

• FX-16EYR-TB, FX-16EYR-ES-TB/UL, FX-16EYT-TB, FX-16EYT-ES-TB/UL, FX-16EYT-ESS-TB/UL, FX-16EYS-TB, FX-16EYS-ES-TB/UL

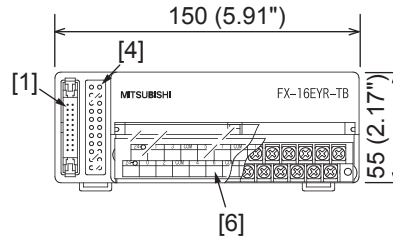

Unit: mm (inches)

No.	Name	Description
[1]	CN1 connector	Connector for connecting input signal cables or output signal cables for CN1
[2]	CN2 connector	Connector for connecting input signal cables or output signal cables for CN2 (FX-32E-TB and FX-32E-TB/UL only)
[3]	POWER LED	Indicates the conduction status. (FX-16EX-A1-TB only) Lit: Powered Off: Not powered or hardware error
[4]	Operation display LED	Turns on when the output is on. (FX-16EYR-TB, FX-16EYR-ES-TB/UL, FX-16EYT-TB, FX-16EYT-ES-TB/UL, FX-16EYTESS-TB/UL, FX-16EYS-TB, and FX-16EYS-ES-TB/UL only)
[5]	Terminal block for CN2 (M3.5 screws)	Input/output terminals for CN2 (FX-32E-TB and FX-32E-TB/UL only)
[6]	Terminal block for CN1 (M3.5 screws)	Input/output terminals for CN1

Terminal layout

- FX-16E-TB, FX-16E-TB/UL

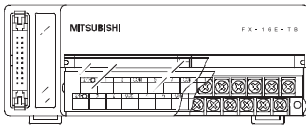

Smaller numbers										Larger numbers					
•	1	3	COM	5	7	COM	1	3	COM	5	7	COM			
•	0	2	COM	4	6	COM	0	2	COM	4	6	COM			

- FX-32E-TB, FX-32E-TB/UL

Smaller numbers										Larger numbers					
CN2	•	1	3	COM	5	7	COM	1	3	COM	5	7	COM		
	•	0	2	COM	4	6	COM	0	2	COM	4	6	COM		

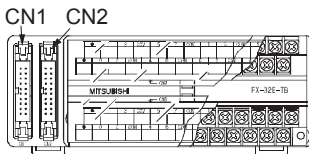

Smaller numbers										Larger numbers					
CN1	•	1	3	COM	5	7	COM	1	3	COM	5	7	COM		
	•	0	2	COM	4	6	COM	0	2	COM	4	6	COM		

- FX-16EX-A1-TB

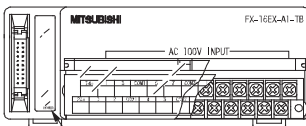

Smaller numbers										Larger numbers					
24+	1	3	COM1	5	7	COM2	1	3	COM3	5	7	COM4			
24-	0	2	COM1	4	6	COM2	0	2	COM3	4	6	COM4			

- FX-16EYR-TB, FX-16EYR-ES-TB/UL, FX-16EYT-TB, FX-16EYT-ES-TB/UL, FX-16EYT-ESS-TB/UL, FX-16EYS-TB, FX-16EYS-ES-TB/UL

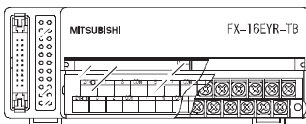

Smaller numbers										Larger numbers					
24+	1	3	COM1	5	7	COM2	1	3	COM3	5	7	COM4			
24-	0	2	COM1	4	6	COM2	0	2	COM3	4	6	COM4			

Internal circuit

FX-16E-TB, FX-32E-TB

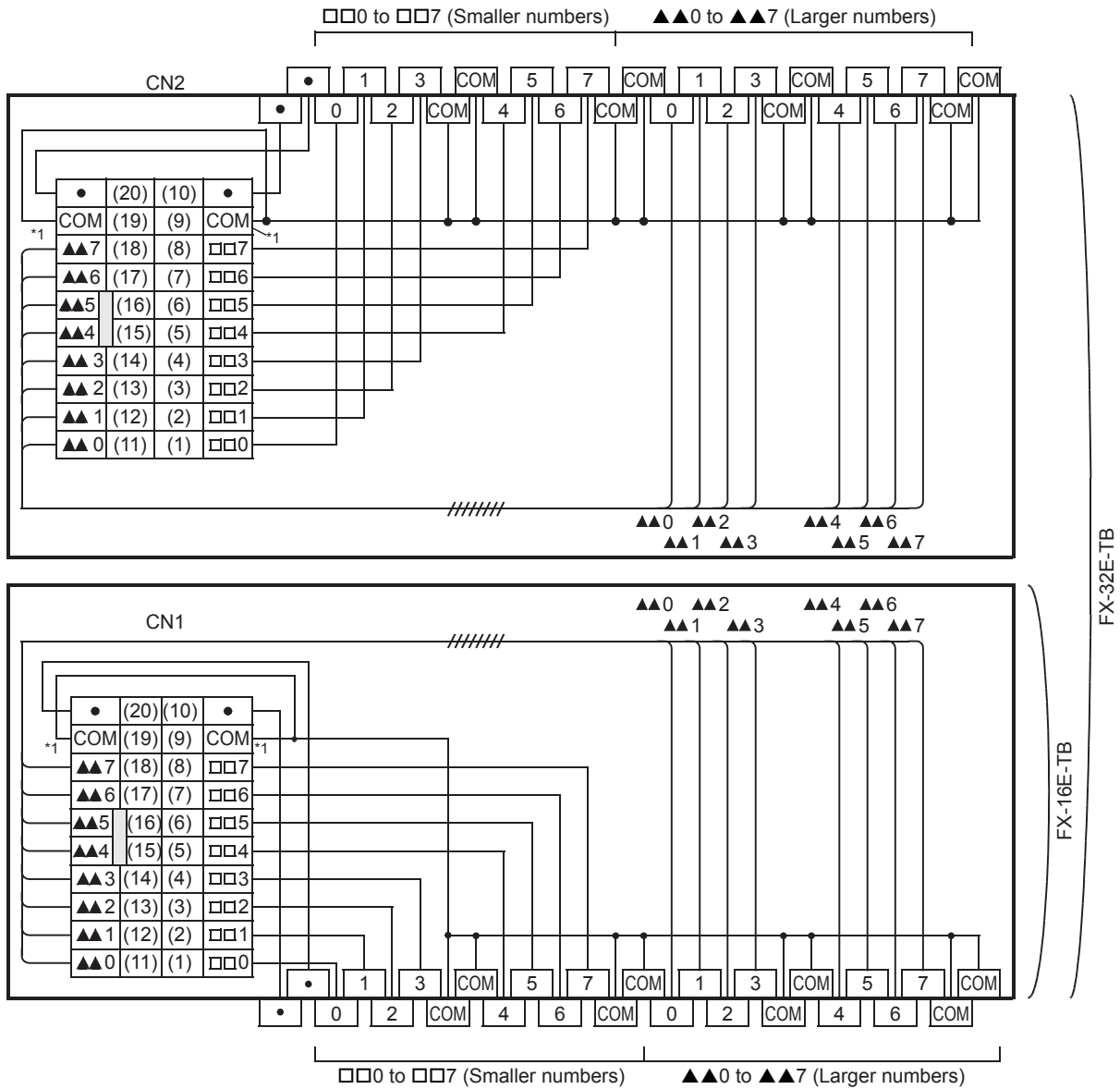

*1 Replace this number with the one of the connected connector.

FX-16EX-A1-TB

A

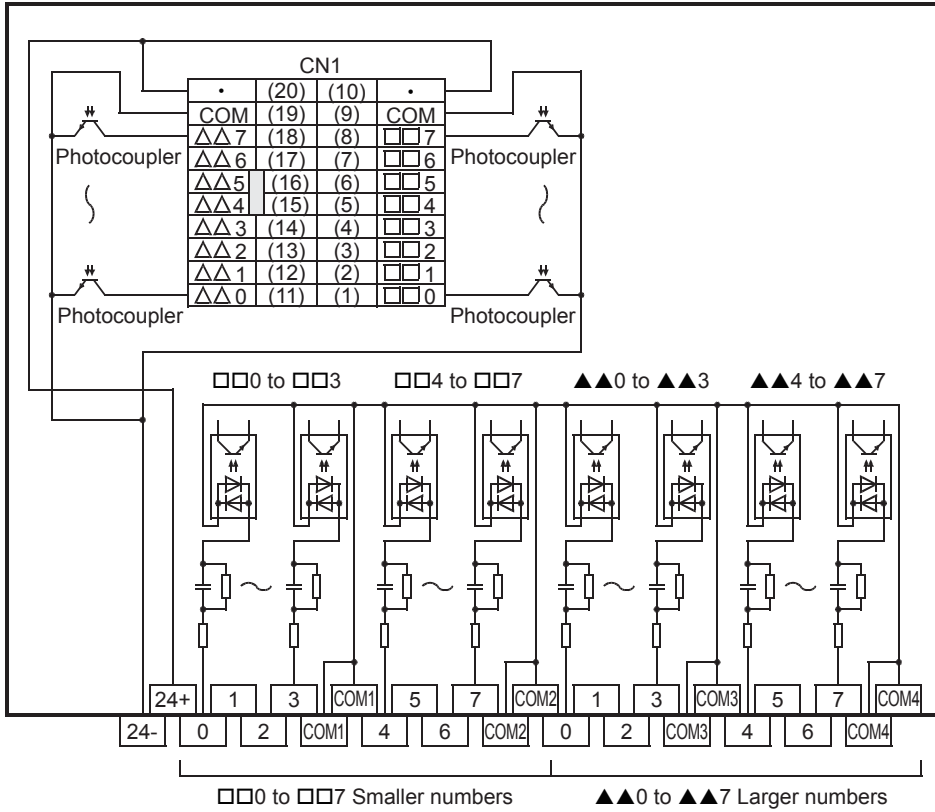

FX-16EYR-TB

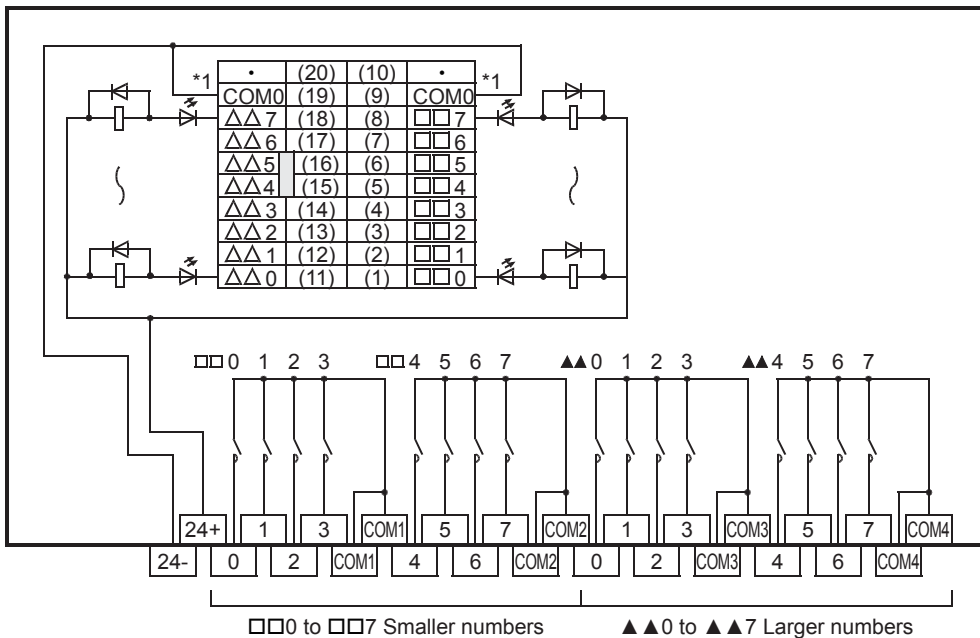

*1 Replace this number with the one of the connected connector.

FX-16EYR-ES-TB/UL

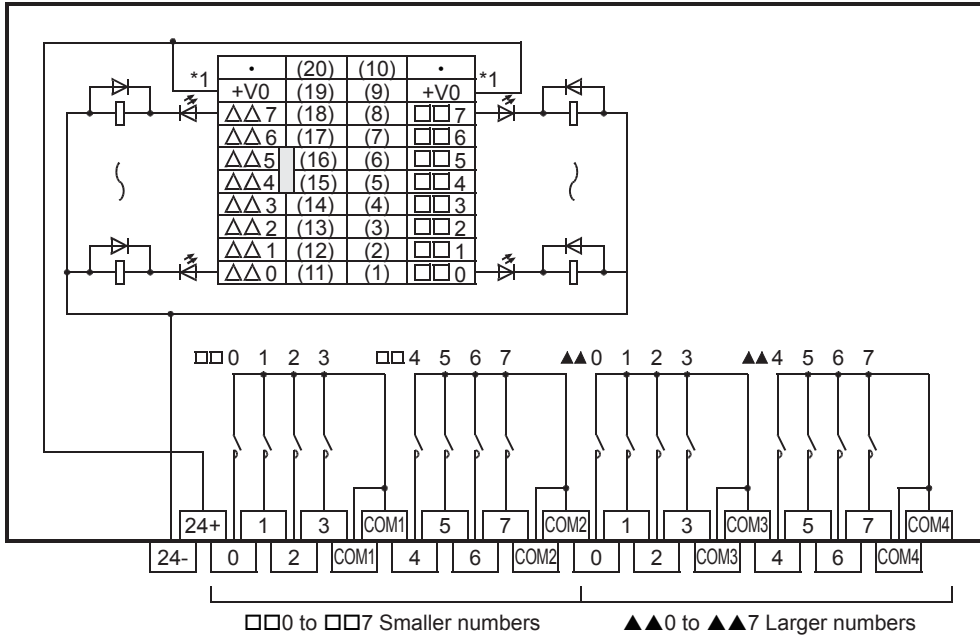

*1 Replace this number with the one of the connected connector.

FX-16EYT-TB

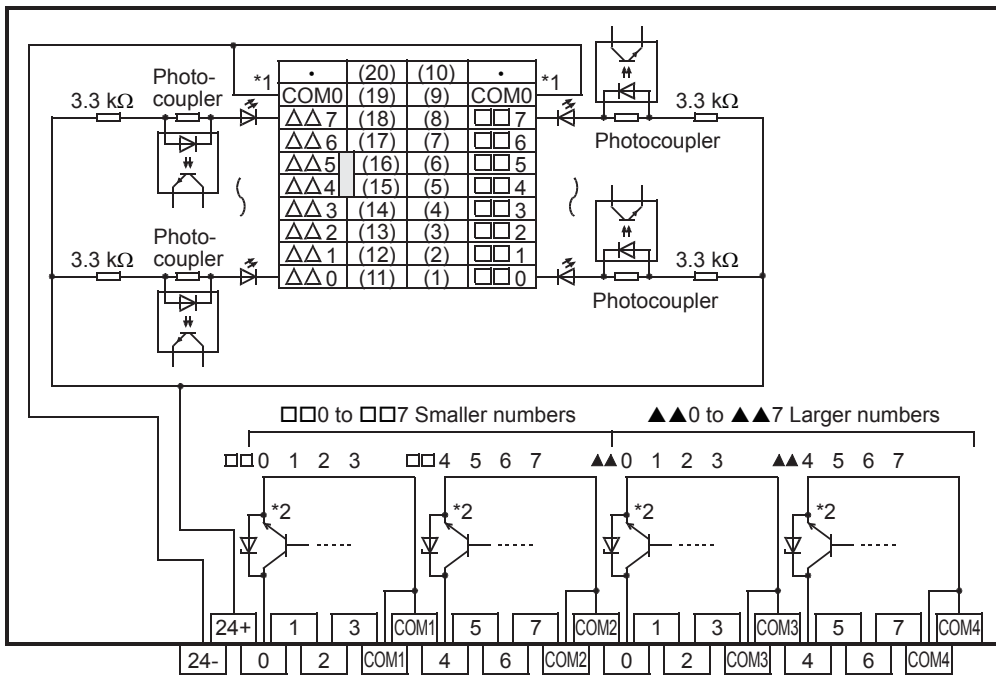

*1 Replace this number with the one of the connected connector.

FX-16EYT-ES-TB/UL

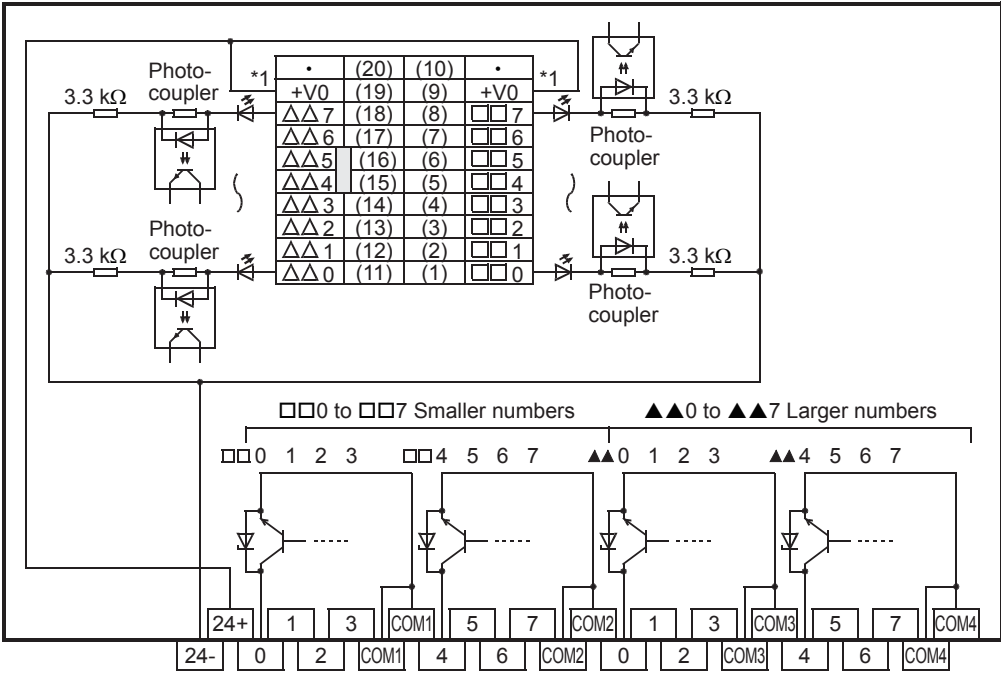

*1 Replace this number with the one of the connected connector.

FX-16EYT-ESS-TB/UL

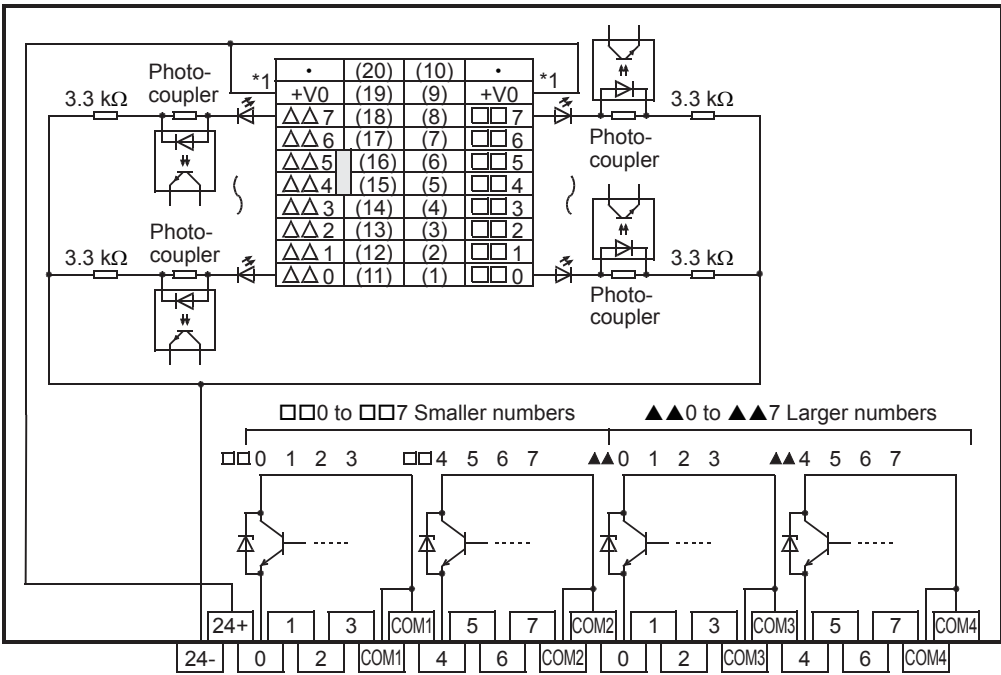

*1 Replace this number with the one of the connected connector.

FX-16EYS-TB

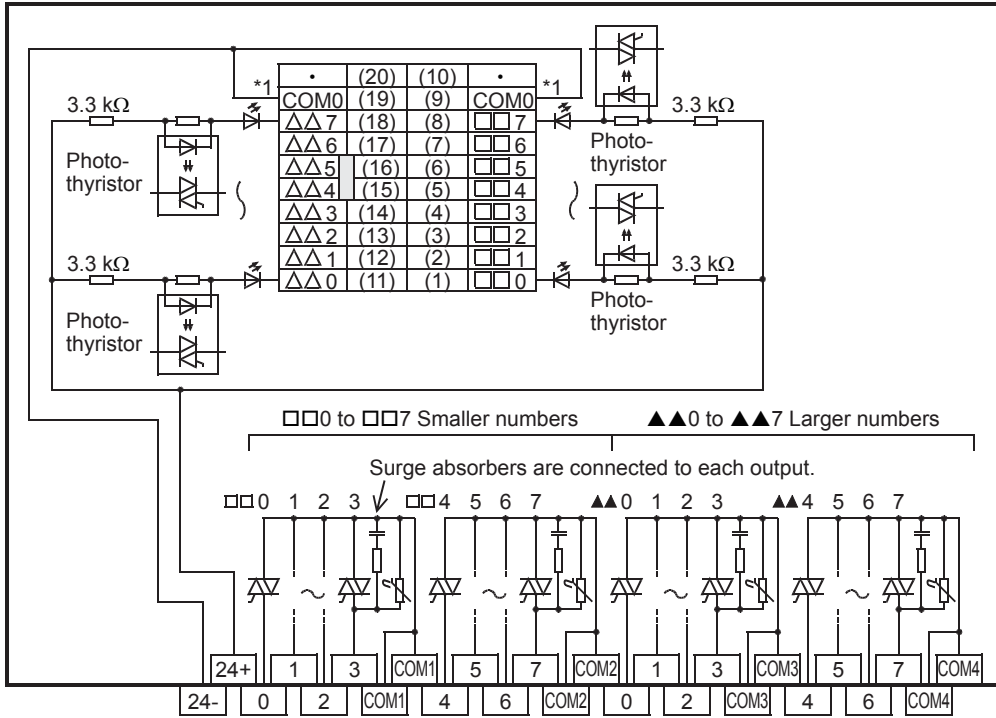

*1 Replace this number with the one of the connected connector.

FX-16EYS-ES-TB/UL

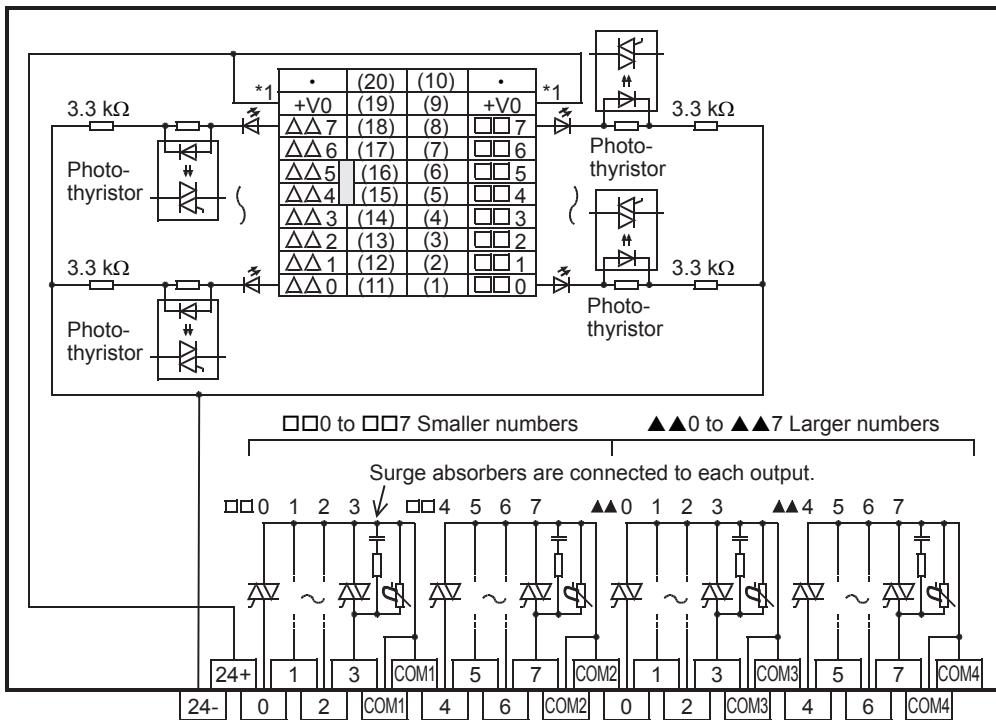

*1 Replace this number with the one of the connected connector.

Appendix 6 Precautions for Battery Transportation

When transporting lithium batteries, follow required transportation regulations.
Batteries used in the FX5UC CPU modules are classified as follows.

Control-subject product

Built-in

None (FX5UC CPU modules do not include batteries when shipped from the factory.)

Battery only (spare parts and optional parts)

Model	Battery type	Product form	Lithium contained (g/battery)	Weight ^{*1} (g/battery)
FX3U-32BL	Lithium-metal battery	Cell	0.15	30

*1 Weight in packaging.

Precautions for transportation

When transporting the product above, follow IATA Dangerous Goods Regulations, IMDG Code (International Maritime Dangerous Goods Code), and domestic transportation regulations in each country. For details, contact the transportation company to be used.

Appendix 7 Handling of Batteries and Devices with Built-in Batteries in EU Member States

This section describes the precautions for disposing of waste batteries in EU member states and exporting batteries and/or devices with built-in batteries to EU member states.

Disposal precautions

In EU member states, there is a separate collection system for waste batteries.

Dispose of batteries properly at the local community waste collection/recycling center.

The symbol shown in the following figure is printed on the batteries and packaging of batteries and devices with built-in batteries. This symbol indicates that batteries need to be disposed of separately from other wastes.



Restriction

This symbol is for EU member states only.

The symbol is specified in the new EU Battery Directive (2006/66/EC) Article 20 "Information for end-users" and Annex II.

Exportation precautions

The new EU Battery Directive (2006/66/EC) requires the following when marketing or exporting batteries and/or devices with built-in batteries to EU member states.

- To print the symbol on batteries, devices, or their packaging
- To explain the symbol in the manuals of the products

Labeling

To market or export batteries and/or devices with built-in batteries, which have no symbol, to EU member states, print the symbol shown in the figure above on the batteries, devices, or their packaging.

Explaining the symbol in the manuals

To export devices incorporating Mitsubishi programmable controllers to EU member states, provide the latest manuals that include the explanation of the symbol. If no Mitsubishi manuals are provided, separately attach an explanatory note regarding the symbol to each manual of the devices.

Point

The requirements apply to batteries and/or devices with built-in batteries manufactured before the enforcement date of the new EU Battery Directive (2006/66/EC).

INDEX

B

BAT LED	14
Battery cover	16
Built-in Ethernet communication connector	14
Built-in RS-485 communication terminal block	14

C

CARD LED	14
--------------------	----

D

DIN rail mounting groove	15
DIN rail mounting hook	15
DISP switch	14

E

ERR LED	14
Expansion adapter connecting hooks	14
Expansion adapter connector cover	15
Extension module connecting hook	14

G

Genuine product certification label	15
---	----

I

I/O display LED	14
Input connector	14
Installation Location	43

M

Memory capacity	21
---------------------------	----

N

Nameplate	15
Number of input/output points	34

O

Operation status display LED	14
Output connector	15

P

P.RUN LED	14
Power connector for CPU module	16
PWR LED	14

R

RD LED	14
Remote I/O points	39
RS-485 terminal resistor selector switch	16
RUN/STOP/RESET switch	15

S

SD LED	14
SD memory card disable switch	15
SD memory card slot	15
SD/RD LED	14
Sink input	59
Source input	59
Subsequent extension connector cover	15

REVISIONS

Revision date	Revision	Description
January 2015	A	First Edition

This manual confers no industrial property rights or any rights of any other kind, nor does it confer any patent licenses. Mitsubishi Electric Corporation cannot be held responsible for any problems involving industrial property rights which may occur as a result of using the contents noted in this manual.

© 2015 MITSUBISHI ELECTRIC CORPORATION

WARRANTY

Please confirm the following product warranty details before using this product.

1. Gratis Warranty Term and Gratis Warranty Range

If any faults or defects (hereinafter "Failure") found to be the responsibility of Mitsubishi occurs during use of the product within the gratis warranty term, the product shall be repaired at no cost via the sales representative or Mitsubishi Service Company. However, if repairs are required onsite at domestic or overseas location, expenses to send an engineer will be solely at the customer's discretion. Mitsubishi shall not be held responsible for any re-commissioning, maintenance, or testing on-site that involves replacement of the failed module.

[Gratis Warranty Term]

The gratis warranty term of the product shall be for one year after the date of purchase or delivery to a designated place. Note that after manufacture and shipment from Mitsubishi, the maximum distribution period shall be six (6) months, and the longest gratis warranty term after manufacturing shall be eighteen (18) months. The gratis warranty term of repair parts shall not exceed the gratis warranty term before repairs.

[Gratis Warranty Range]

- 1) The range shall be limited to normal use within the usage state, usage methods and usage environment, etc., which follow the conditions and precautions, etc., given in the instruction manual, user's manual and caution labels on the product.
- 2) Even within the gratis warranty term, repairs shall be charged for in the following cases.
 - a) Failure occurring from inappropriate storage or handling, carelessness or negligence by the user. Failure caused by the user's hardware or software design.
 - b) Failure caused by unapproved modifications, etc., to the product by the user.
 - c) When the Mitsubishi product is assembled into a user's device, Failure that could have been avoided if functions or structures, judged as necessary in the legal safety measures the user's device is subject to or as necessary by industry standards, had been provided.
 - d) Failure that could have been avoided if consumable parts (battery, backlight, fuse, etc.) designated in the instruction manual had been correctly serviced or replaced.
 - e) Relay failure or output contact failure caused by usage beyond the specified life of contact (cycles).
 - f) Failure caused by external irresistible forces such as fires or abnormal voltages, and failure caused by force majeure such as earthquakes, lightning, wind and water damage.
 - g) Failure caused by reasons unpredictable by scientific technology standards at time of shipment from Mitsubishi.
 - h) Any other failure found not to be the responsibility of Mitsubishi or that admitted not to be so by the user.

2. Onerous repair term after discontinuation of production

- 1) Mitsubishi shall accept onerous product repairs for seven (7) years after production of the product is discontinued.
Discontinuation of production shall be notified with Mitsubishi Technical Bulletins, etc.
- 2) Product supply (including repair parts) is not available after production is discontinued.

3. Overseas service

Overseas, repairs shall be accepted by Mitsubishi's local overseas FA Center. Note that the repair conditions at each FA Center may differ.

4. Exclusion of loss in opportunity and secondary loss from warranty liability

Regardless of the gratis warranty term, Mitsubishi shall not be liable for compensation of damages caused by any cause found not to be the responsibility of Mitsubishi, loss in opportunity, lost profits incurred to the user or third person by failure of Mitsubishi products, special damages and secondary damages whether foreseeable or not, compensation for accidents, and compensation for damages to products other than Mitsubishi products, replacement by the user, maintenance of on-site equipment, start-up test run and other tasks.

5. Changes in product specifications

The specifications given in the catalogs, manuals or technical documents are subject to change without prior notice.

6. Product application

- 1) In using the Mitsubishi MELSEC programmable controller, the usage conditions shall be that the application will not lead to a major accident even if any problem or fault should occur in the programmable controller device, and that backup and fail-safe functions are systematically provided outside of the device for any problem or fault.
- 2) The Mitsubishi programmable controller has been designed and manufactured for applications in general industries, etc. Thus, applications in which the public could be affected such as in nuclear power plants and other power plants operated by respective power companies, and applications in which a special quality assurance system is required, such as for railway companies or public service purposes shall be excluded from the programmable controller applications.
In addition, applications in which human life or property that could be greatly affected, such as in aircraft, medical applications, incineration and fuel devices, manned transportation, equipment for recreation and amusement, and safety devices, shall also be excluded from the programmable controller range of applications.
However, in certain cases, some applications may be possible, providing the user consults their local Mitsubishi representative outlining the special requirements of the project, and providing that all parties concerned agree to the special circumstances, solely at the user's discretion.

TRADEMARKS

Microsoft® and Windows® are either registered trademarks or trademarks of Microsoft Corporation in the United States and/or other countries.

Ethernet is a trademark of Xerox Corporation.

Anywire is a registered trademark of the Anywire Corporation.

MODBUS® is a registered trademark of Schneider Electric SA.

Phillips is a registered trademark of Phillips Screw Company.

SD logo and SDHC logo are trademarks or registered trademarks of SD-3C, LLC.



The company name and the product name to be described in this manual are the registered trademarks or trademarks of each company.

Manual number: JY997D61401A

Model: FX5UC-U-HW-E

Model code: 09R558

When exported from Japan, this manual does not require application to the Ministry of Economy, Trade and Industry for service transaction permission.

MITSUBISHI ELECTRIC CORPORATION

HEAD OFFICE: TOKYO BUILDING, 2-7-3 MARUNOUCHI, CHIYODA-KU, TOKYO 100-8310, JAPAN
HIMEJI WORKS: 840, CHIYODA MACHI, HIMEJI, JAPAN

Specifications are subject to change without notice.

HEADQUARTERS		EUROPEAN REPRESENTATIVES		EUROPEAN REPRESENTATIVES		EURASIAN REPRESENTATIVES	
Mitsubishi Electric Europe B.V. Gothaer Straße 8 D-40880 Ratingen Phone: +49 (0)2102 / 486-0 Fax: +49 (0)2102 / 486-1120	EUROPE	GEVA Wiener Straße 89 A-2500 Baden Phone: +43 (0)2252 / 85 55 20 Fax: +43 (0)2252 / 488 60	AUSTRIA	Beijer Electronics SIA Ritausmas iela 23 LV-1058 Riga Phone: +371 (0)6 / 784 2280 Fax: +371 (0)6 / 784 2281	LATVIA	TOO Kazpromavtomatika UL. ZHAMBYLA 28, KAZ-100017 Karaganda Phone: +7 7212 / 50 10 00 Fax: +7 7212 / 50 11 50	KAZAKHSTAN
Mitsubishi Electric Europe B.V. Radlická 751/113e Avenir Business Park CZ-158 00 Praha 5 Phone: +420 251 551 470 Fax: +420 251 551 471	CZECH REP.	000 TECHNIKON Prospect Nezavisimosti 177-9 BY-220125 Minsk Phone: +375 (0)17 / 393 1177 Fax: +375 (0)17 / 393 0081	BELARUS	Beijer Electronics UAB Goštautų g. 3 LT-48324 Kaunas Phone: +370 37 262707 Fax: +370 37 455605	LITHUANIA	MIDDLE EAST REPRESENTATIVE	
Mitsubishi Electric Europe B.V. 25, Boulevard des Bouvets F-92741 Nanterre Cedex Phone: +33 (0)1 / 55 68 55 68 Fax: +33 (0)1 / 55 68 57 57	FRANCE	ESCO DRIVES Culliganlaan 3 BE-1831 Diegem Phone: +32 (0)2 / 717 64 60 Fax: +32 (0)2 / 717 64 61	BELGIUM	ALFATRADE Ltd. 99, Paola Hill Malta-Paola PLA 1702 Phone: +356 (0)21 / 697 816 Fax: +356 (0)21 / 697 817	MALTA	GIRIT CELADON Ltd. 12 H'aomanut Street IL-42505 Netanya Phone: +972 (0)9 / 863 39 80 Fax: +972 (0)9 / 885 24 30	ISRAEL
Mitsubishi Electric Europe B.V. Westgate Business Park, Ballymount IRL-Dublin 24 Phone: +353 (0)1 4198800 Fax: +353 (0)1 4198890	IRELAND	KONING & HARTMAN B.V. Woluwelaan 31 BE-1800 Vilvoorde Phone: +32 (0)2 / 257 02 40 Fax: +32 (0)2 / 257 02 49	BELGIUM	INTEHSIS SRL bld. Traian 23/1 MD-2060 Kishinev Phone: +373 (0)22 / 66 4242 Fax: +373 (0)22 / 66 4280	MOLDOVA	CEG LIBAN Cebaco Center/Block A Autostrade DORA Lebanon-Beirut Phone: +961 (0)1 / 240 445 Fax: +961 (0)1 / 240 193	LEBANON
Mitsubishi Electric Europe B.V. Viale Colleoni 7 Palazzo Sirio I-20864 Agrate Brianza (MB) Phone: +39 039 / 60 53 1 Fax: +39 039 / 60 53 312	ITALY	INEA RBT d.o.o. Stegne 11 SI-1000 Ljubljana Phone: +386 (0)1 / 513 8116 Fax: +386 (0)1 / 513 8170	BOSNIA AND HERZEGOVINA	HIFLEX AUTOM. B.V. Wolweverstraat 22 NL-2984 CD Ridderkerk Phone: +31 (0)180 / 46 60 04 Fax: +31 (0)180 / 44 23 55	NETHERLANDS	AFRICAN REPRESENTATIVE	
Mitsubishi Electric Europe B.V. Nijverheidsweg 23a NL-3641RP Mijdrecht Phone: +31 (0) 297250350	NETHERLANDS	AKHNATON 4, Andrei Ljapchev Blvd., PO Box 21 BG-1756 Sofia Phone: +359 (0)2 / 817 6000 Fax: +359 (0)2 / 97 44 06 1	BULGARIA	KONING & HARTMAN B.V. Energieweg 1 NL-2627 AP Delft Phone: +31 (0)15 260 99 06 Fax: +31 (0)15 261 9194	NETHERLANDS	ADROIT TECHNOLOGIES 20 Waterford Office Park 189 Witkoppen Road ZA-Fourways Phone: +27 (0)11 / 658 8100 Fax: +27 (0)11 / 658 8101	SOUTH AFRICA
Mitsubishi Electric Europe B.V. ul. Krakowska 50 PL-32-083 Balice Phone: +48 (0) 12 347 65 00 Fax: +48 (0) 12 347 65 01	POLAND	INEA CR Losinjska 4 a HR-10000 Zagreb Phone: +385 (0)1 / 36 940 - 01/ -02/ -03 Fax: +385 (0)1 / 36 940 - 03	CROATIA	Beijer Electronics AS Postboks 487 NO-3002 Drammen Phone: +47 (0)32 / 24 30 00 Fax: +47 (0)32 / 84 85 77	NORWAY		
Mitsubishi Electric (Russia) LLC 52, bld. 1 Kosmodamianskaya emb. RU-115054 Moscow Phone: +7 495 / 721 2070 Fax: +7 495 / 721 2071	RUSSIA	AutoCont C. S. S.R.O. Kačkova 1853/3 CZ-702 00 Ostrava 2 Phone: +420 595 691 150 Fax: +420 595 691 199	CZECH REPUBLIC	Fonseca S.A. R. João Francisco do Casal 87/89 PT-3801-997 Aveiro, Esqueiroa Phone: +351 (0)234 / 303 900 Fax: +351 (0)234 / 303 910	PORTUGAL		
Mitsubishi Electric Europe B.V. Carretera de Rubi 76-80 Apdo. 420 E-08190 Sant Cugat del Vallés (Barcelona) Phone: +34 (0) 93 / 5653131 Fax: +34 (0) 93 / 5891579	SPAIN	Beijer Electronics A/S Lykkegardsvej 17 DK-4000 Roskilde Phone: +45 (0)46 / 75 76 66 Fax: +45 (0)46 / 75 56 26	DENMARK	SIRIUS TRADING & SERVICES SRL Aleea Lacul Morii Nr. 3 RO-060841 Bucuresti, Sector 6 Phone: +40 (0)21 / 430 40 06 Fax: +40 (0)21 / 430 40 02	ROMANIA		
Mitsubishi Electric Europe B.V. (Scandinavia) Fjellievägen 8 SE-22736 Lund Phone: +46 (0) 8 625 10 00 Fax: +46 (0) 46 39 70 18	SWEDEN	HANS FÖLSGAARD A/S Theilgaardstr. 1 DK-4600 Køge Phone: +45 4320 8600 Fax: +45 4396 8855	DENMARK	INEA SR d.o.o. Ul. Karadjordjeva 12/217 SER-11300 Smederevo Phone: +386 (0)26 461 54 01	SERBIA		
Mitsubishi Electric Turkey Elektrik Ürünleri A.Ş. Fabrika Otomasyon Merkezi Şerifali Mahallesi Nutuk Sokak No.5 TR-34775 Ümraniye-İSTANBUL Phone: +90 (0)216 / 526 39 90 Fax: +90 (0)216 / 526 39 95	TURKEY	Beijer Electronics Eesti OÜ Pärnu mnt.160i EE-11317 Tallinn Phone: +372 (0)6 / 51 81 40 Fax: +372 (0)6 / 51 81 49	ESTONIA	SIMAP SK (Západné Slovensko) Jána Derku 1671 SK-911 01 Trenčín Phone: +421 (0)32 743 04 72 Fax: +421 (0)32 743 75 20	SLOVAKIA		
Mitsubishi Electric Europe B.V. Travellers Lane UK-Hatfield, Herts. AL10 8XB Phone: +44 (0)1707 / 28 87 80 Fax: +44 (0)1707 / 27 86 95	UK	Beijer Electronics OY Vanha Nurmijärventie 62 FIN-01670 Vantaa Phone: +358 (0)207 / 463 500 Fax: +358 (0)207 / 463 501	FINLAND	INEA RBT d.o.o. Stegne 11 SI-1000 Ljubljana Phone: +386 (0)1 / 513 8116 Fax: +386 (0)1 / 513 8170	SLOVENIA		
Mitsubishi Electric Europe B.V. Dubai Silicon Oasis United Arab Emirates - Dubai Phone: +971 4 3724716 Fax: +971 4 3724721	UAE	PROVENDOR OY Teljänkatu 8 A3 FIN-28130 Pori Phone: +358 (0) 2 / 522 3300 Fax: +358 (0) 2 / 522 3322	FINLAND	Beijer Electronics Automation AB Box 426 SE-20124 Malmö Phone: +46 (0)40 / 35 86 00 Fax: +46 (0)40 / 93 23 01	SWEDEN		
Mitsubishi Electric Corporation Tokyo Building 2-7-3 Marunouchi, Chiyoda-ku Tokyo 100-8310 Phone: +81 (3) 3218-2111 Fax: +81 (3) 3218-2185	JAPAN	UTECO A.B.E.E. 5, Mavrogenou Str. GR-18542 Piraeus Phone: +30 (0)211 / 1206-900 Fax: +30 (0)211 / 1206-999	GREECE	OMNI RAY AG Im Schörl 5 CH-8600 Dübendorf Phone: +41 (0)44 / 802 28 80 Fax: +41 (0)44 / 802 28 28	SWITZERLAND		
Mitsubishi Electric Automation, Inc. 500 Corporate Woods Parkway Vernon Hills, IL 60061 Phone: +1 (847) 478-2100 Fax: +1 (847) 478-0328	USA	MELTRADE Kft. Fertő utca 14. HU-1107 Budapest Phone: +36 (0)1 / 431-9726 Fax: +36 (0)1 / 431-9727	HUNGARY	OOO "CSC-AUTOMATION" 4-B, M. Raskovoy St. UA-02660 Kiev Phone: +380 (0)44 / 494 33 44 Fax: +380 (0)44 / 494-33-66	UKRAINE		