



PROGRAMMABLE CONTROLLERS



MELSEC iQ-F
series



MELSEC iQ-F
FX5 User's Manual (Application)

SAFETY PRECAUTIONS

(Read these precautions before use.)

Before using this product, please read this manual and the relevant manuals introduced in this manual carefully and pay attention to safety in order to handle the product correctly.

This manual classifies the safety precautions into two categories: [ WARNING] and [ CAUTION].

 WARNING	Indicates that incorrect handling may cause hazardous conditions, resulting in death or severe injury.
 CAUTION	Indicates that incorrect handling may cause hazardous conditions, resulting in minor or moderate injury or property damage.

Depending on the circumstances, procedures indicated by [ CAUTION] may also cause severe injury.

It is important to follow all precautions for personal safety.

Store this manual in a safe place so that it can be read whenever necessary. Always forward it to the end user.

[DESIGN PRECAUTIONS]

WARNING

- Make sure to set up the following safety circuits outside the PLC to ensure safe system operation even during external power supply problems or PLC failure. Otherwise, malfunctions may cause serious accidents.
 - Most importantly, set up the following: an emergency stop circuit, a protection circuit, an interlock circuit for opposite movements (such as forward vs. reverse rotation), and an interlock circuit to prevent damage to the equipment at the upper and lower positioning limits.
 - Note that when the CPU module detects an error, such as a watchdog timer error, during self-diagnosis, all outputs are turned off. Also, when an error that cannot be detected by the CPU module occurs in an input/output control block, output control may be disabled. External circuits and mechanisms should be designed to ensure safe machine operation in such a case.
 - Note that the output current of the 24 V DC service power supply varies depending on the model and the absence/presence of extension modules. If an overload occurs, the voltage automatically drops, inputs in the PLC are disabled, and all outputs are turned off. External circuits and mechanisms should be designed to ensure safe machine operation in such a case.
 - Note that when an error occurs in a relay or transistor of an output circuit, the output might stay on or off. For output signals that may lead to serious accidents, external circuits and mechanisms should be designed to ensure safe machine operation.
 - Construct an interlock circuit in the program to ensure safe operation for the whole system when executing control (for data change) of the PLC in operation.

Read the manual thoroughly and ensure complete safety before executing other controls (for program change, parameter change, forced output and operation status change) of the PLC in operation. Otherwise, the machine may be damaged and accidents may occur due to erroneous operations.
 - In an output circuit, when a load current exceeding the current rating or an overcurrent caused by a load short-circuit flows for a long time, it may cause smoke and fire. To prevent this, configure an external safety circuit, such as a fuse.
 - For the operating status of each station after a communication failure of the network, refer to relevant manuals for the network. Incorrect output or malfunction may result in an accident.
-

[DESIGN PRECAUTIONS]

CAUTION

- After the CPU module is powered on or is reset, the time taken to enter the RUN status varies depending on the system configuration, parameter settings, and/or program size.
Design circuits so that the entire system will always operate safely, regardless of this variation in time.
-

[INSTALLATION PRECAUTIONS]

CAUTION

- Connect the expansion board and expansion adapter securely to their designated connectors. Loose connections may cause malfunctions.
 - Connect the extension cables, peripheral device cables, input/output cables and battery connecting cable securely to their designated connectors. Loose connections may cause malfunctions.
 - When using an SD memory card, insert it into the SD memory card slot. Check that it is inserted completely. Poor contact may cause malfunction.
 - Turn off the power to the PLC before attaching or detaching the following devices. Failure to do so may cause device failures or malfunctions.
 - Peripheral devices, expansion board and expansion adapter
 - Extension modules, bus conversion module and connector conversion module
 - Battery
-

[WIRING PRECAUTIONS]

CAUTION

- Do not bundle the power line, control line and communication cables together with or lay them close to the main circuit, high-voltage line, load line or power line. As a guideline, lay the power line, control line and connection cables at least 100 mm (3.94") away from the main circuit, high-voltage line, load line or power line. Noise may cause malfunctions.
-

[STARTUP AND MAINTENANCE PRECAUTIONS]

WARNING

- Do not touch any terminal while the PLC's power is on. Doing so may cause electric shock or malfunctions.
 - Before modifying the program in mid-operation, forcing output, running or stopping the PLC, read this manual and the associated manuals carefully and ensure complete safety. An operation error may damage the machinery or cause accidents.
 - Do not change the program in the PLC from two or more peripheral equipment devices (such as an engineering tool and a GOT) at the same time. Doing so may cause destruction or malfunction of the PLC program.
 - Use the battery for memory backup in conformance to the FX5 User's Manual (Hardware).
 - Use the battery for the specified purpose only.
 - Connect the battery correctly.
 - Do not charge, disassemble, heat, put in fire, short-circuit, connect reversely, weld, swallow or burn the battery, or apply excessive force (vibration, impact, drop, etc.) to the battery.
 - Do not store or use the battery at high temperatures or expose to direct sunlight.
 - Do not expose to water, bring near fire or touch liquid leakage or other contents directly.Incorrect handling of the battery may cause excessive heat, bursting, ignition, liquid leakage or deformation, and lead to injury, fire or failures and malfunction of facilities and other equipment.
-

[PRECAUTIONS IN OPERATION]

CAUTION

- Construct an interlock circuit in the program to ensure safe operation for the whole system when executing control (for data change) of the PLC in operation. Read the manual thoroughly and ensure complete safety before executing other controls (for program change, parameter change, forced output and operation status change) to the PLC in operation. Otherwise, the machine may be damaged and accidents may occur by erroneous operations.
-

INTRODUCTION

This manual contains text, diagrams and explanations which will guide the reader in the correct installation, safe use and operation of the FX5 Programmable Controllers and should be read and understood before attempting to install or use the module.

Always forward it to the end user.

Regarding use of this product

- This product has been manufactured as a general-purpose part for general industries, and has not been designed or manufactured to be incorporated in a device or system used in purposes related to human life.
- Before using the product for special purposes such as nuclear power, electric power, aerospace, medicine or passenger movement vehicles, consult Mitsubishi Electric.
- This product has been manufactured under strict quality control. However when installing the product where major accidents or losses could occur if the product fails, install appropriate backup or failsafe functions in the system.

Note

- If in doubt at any stage during the installation of the product, always consult a professional electrical engineer who is qualified and trained in the local and national standards. If in doubt about the operation or use, please consult the nearest Mitsubishi Electric representative.
- Since the examples indicated by this manual, technical bulletin, catalog, etc. are used as a reference, please use it after confirming the function and safety of the equipment and system. Mitsubishi Electric will accept no responsibility for actual use of the product based on these illustrative examples.
- This manual content, specification etc. may be changed without a notice for improvement.
- The information in this manual has been carefully checked and is believed to be accurate; however, if you notice a doubtful point, an error, etc., please contact the nearest Mitsubishi Electric representative. When doing so, please provide the manual number given at the end of this manual.

MEMO

CONTENTS

SAFETY PRECAUTIONS	1
INTRODUCTION	4
RELEVANT MANUALS	12
TERMS	12

PART 1 PROGRAMMING

CHAPTER 1 PROGRAM EXECUTION 16

1.1 Scan Configuration	16
Initial processing and initialization processing in RUN mode	16
I/O refresh	17
Program operations	17
END processing	17
1.2 Scan Time	18
Initial scan time	18
1.3 Program Execution Sequence	19
1.4 Execution Type of Program	20
Initial execution type program	20
Scan execution type program	21
Fixed scan execution type program	21
Event execution type program	25
Stand-by type program	28
1.5 Program Type	29
Subroutine program	29
Interrupt program	30

CHAPTER 2 PROCESSING OF OPERATIONS ACCORDING TO CPU MODULE OPERATION STATUS 35

CHAPTER 3 CPU MODULE MEMORY CONFIGURATION 37

3.1 Memory Configuration	37
Memory configuration	37
3.2 Files	39
File type and storage destination memory	39
Executable file operations	39

PART 2 FUNCTIONS

CHAPTER 4 FUNCTION LIST 42

CHAPTER 5 SCAN MONITORING FUNCTION 44

5.1 Scan time monitoring time setting	44
5.2 Resetting of the watchdog timer	44
5.3 Precautions	44
Watchdog timer reset when executing a program repeatedly	44
Scan time when the WDT instruction is used	45

CHAPTER 6	CLOCK FUNCTION	46
6.1	Time Setting	46
	Clock data	46
	Changing the clock data	46
	Reading clock data	47
	Precautions	47
6.2	Setting Time Zone	48
6.3	System clock	49
	Special relay used for system clock	49
	Special register used for system clock	49
CHAPTER 7	ONLINE CHANGE	50
7.1	Online Ladder Block Change	50
	Editable contents	50
	Range changeable in a single session	50
	Online ladder block change during the boot operation	50
	Precautions	50
CHAPTER 8	INTERRUPT FUNCTION	53
8.1	Multiple Interrupt Function	53
	Interrupt priority	53
CHAPTER 9	PID CONTROL FUNCTION	55
9.1	Outline of Function	55
9.2	Basic Operation Expressions in PID Instruction	55
	Basic operation expression for PID control	55
9.3	How to Use PID Instruction	56
9.4	Relationship Between Parameter Setting and Auto-Tuning	57
	When auto-tuning is not executed (parameter setting)	57
	When auto-tuning is executed	57
9.5	Parameter	58
9.6	Details of Parameters	59
	Sampling time (s3)	59
	Operation setting (S3)+1	59
	Input filter constant (s3)+2	61
	Proportional gain (s3)+3	62
	Integral time (s3)+4	63
	Differential gain (s3)+5	64
	Differential time (s3)+6	65
	Alarm output (s3)+24	67
9.7	Auto-Tuning	68
	Limit Cycle Method	68
	Step Response Method	71
9.8	Examples of Program	73
	System configuration example	73
	Program example 1	74
	Program example 2	76
	Program example 3	78
	Program example 4	80
	Program example 5	82

CHAPTER 10 CONSTANT SCAN	84
10.1 Constant scan settings	84
CHAPTER 11 REMOTE OPERATION	86
11.1 Remote RUN/STOP	86
Applications of remote RUN/STOP	86
Operation during remote RUN/STOP	86
Method of execution of remote RUN/STOP	86
11.2 Remote PAUSE	88
Application of remote PAUSE	88
Method of execution of remote PAUSE	88
11.3 Remote RESET	89
Application of remote RESET	89
Enabling remote RESET	89
Method of execution of remote RESET	90
11.4 Relationship Between Remote Operation and CPU Module	91
CHAPTER 12 DEVICE/LABEL MEMORY AREA SETTING	92
12.1 Default Capacity of Each Area	92
12.2 The Setting Range of the Capacity of Each Area	93
12.3 Device/Label Memory Area Setting	94
12.4 Device Setting	95
Range of use of device points	96
CHAPTER 13 INITIAL DEVICE VALUE SETTING	97
13.1 Setting Initial Device Values	97
Setting initial device values	97
13.2 Applicable Devices	98
CHAPTER 14 LATCH FUNCTION	99
14.1 Types of Latch	99
14.2 Device/label that can be Latched	99
14.3 Latch Settings	100
Latch settings	100
Setting latch on labels	101
14.4 Clearing of Data of the Latch Range	101
14.5 Precautions	102
CHAPTER 15 MEMORY CARD FUNCTION	103
15.1 SD Memory Card Forced Stop	103
15.2 Boot Operation	104
CHAPTER 16 DEVICE/LABEL ACCESS SERVICE PROCESSING SETTING	107
CHAPTER 17 RAS FUNCTIONS	109
17.1 Self-Diagnostics Function	109
Self-diagnostics timing	109
Check method of error	109
CPU Module Operation Upon Error Detection Setting	110
Error Clear	112

19.1	High-speed Counter Function	114
	High-speed counter function overview	114
	High-speed counter function execution procedure	115
	High-speed counter specifications	115
	Assignment for high-speed counters	119
	High-speed counter parameters	123
	High-speed counter (normal mode)	124
	High-speed counter (pulse density measurement mode)	126
	High-speed counter (rotational speed measurement mode)	129
	High-speed comparison table	132
	Multiple point output, high-speed comparison tables	134
	Special relay list	137
	Special relay details	140
	Special registers list	148
	Special register details	152
	Special relays/special registers capable of high-speed transfers with the HCMOV instruction	161
	Precautions when using high-speed counters	163
19.2	FX3-compatible high-speed counter function	165
	FX3-compatible high-speed counter function overview	165
	How to start/stop the high-speed counter using the LC device	165
	The elements of the composition of the LC device	166
	The comparison between the UDCNTF instruction and HIOEN instruction	166
	Assignment for FX3-compatible high-speed counters	167
	FX3-compatible high-speed counter setting	169
	FX3-compatible high-speed counter	169
	Special relay list	171
	Special relays/LC devices capable of high-speed transfers with the HCMOV instruction	172
	Precautions when using FX3-compatible high-speed counters	173
19.3	Pulse Width Measurement Function	174
	Pulse width measurement function overview	174
	Pulse width measurement specifications	174
	Pulse measurement function execution procedure	175
	Pulse width measurement parameters	176
	List of special relays/special registers	177
	Details of special relays/special registers	178
	Cautions when using the pulse width measurement function	182
	Examples of program	183
19.4	Pulse Catch Function	184
	Outline of pulse catch function	184
	Specifications of pulse catch function	184
	Pulse catch function execution procedure	184
	Pulse catch parameters	185
	Operation of pulse catch function	186
	Cautions when using the pulse catch function	187
19.5	FX3-Compatible Pulse Catch Function	188
	Outline of FX3-compatible pulse catch function	188
	Specifications of FX3-compatible pulse catch function	188

	FX3-compatible pulse catch function execution procedure	189
	FX3-compatible pulse catch parameters	189
	Operation of FX3-compatible pulse catch function	190
	Cautions when using the FX3-compatible pulse catch function	190
19.6	General-purpose Input Functions	191
	Outline of general-purpose input functions	191
	Specifications of general-purpose inputs	191
	General-purpose input function parameters	192
19.7	PWM Function	193
	Outline of PWM output	193
	PWM output specifications	193
	PWM output function execution procedure	194
	PWM output parameters	195
	List of Special relays/special registers	196
	Details of special relays/special registers	196
	Cautions when using the PWM function	199
	Examples of program	199

CHAPTER 20 BUILT-IN ANALOG FUNCTION 201

20.1	Function Outline	201
20.2	Analog Input/Output Specifications	201
	Analog input specifications	201
	Analog output specifications	201
	List of analog input functions	202
	List of analog output functions	202

PART 3 DEVICES/LABELS

CHAPTER 21 DEVICES 204

21.1	List of Devices	204
21.2	User Devices	205
	Input (X)	205
	Output (Y)	205
	Internal relay (M)	206
	Latch relay (L)	206
	Link relay (B)	206
	Annunciator (F)	206
	Link special relay (SB)	208
	Step relay (S)	208
	Timer (T/ST)	209
	Counter (C/LC)	212
	Data register (D)	215
	Link register (W)	215
	Link special register (SW)	215
21.3	System Devices	215
	Special relay (SM)	215
	Special register (SD)	215
21.4	Module Access Device	216
	Specification method	216
	Processing speed	216

21.5	Index Registers (Z/LZ)	217
	Types of index registers	217
	Index register setting	217
21.6	File Register (R)	218
21.7	Nesting (N)	218
21.8	Pointer (P)	219
	Global pointers	219
	Label assignment pointers	219
21.9	Interrupt Pointer (I)	219
	Interrupt causes of the interrupt pointer numbers	220
	The priority for the interrupt pointer numbers and interrupt factors	220
21.10	Constant	221
	Decimal constant (K)	221
	Hexadecimal constant (H)	221
	Real constant (E)	221
	Character string constant	221
CHAPTER 22 LABELS		222
<hr/>		
APPENDIX		224
<hr/>		
Appendix 1 Special Relay List		224
Appendix 2 Special Register List		240
Appendix 3 Error Code		274
	Error code system	274
	Operation when an error occurs	274
	How to clear errors	275
	List of error codes	275
Appendix 4 Parameter List		291
	System parameters	291
	CPU parameters	291
	Module parameters	292
	Memory card parameters	297
INDEX		298
<hr/>		
REVISIONS		300
WARRANTY		301
TRADEMARKS		302

RELEVANT MANUALS

User's manuals for the applicable modules

Manual name <manual number>	Description
MELSEC iQ-F FX5 User's Manual (Startup) <JY997D58201>	Performance specifications, procedures before operation, and troubleshooting of the CPU module.
MELSEC iQ-F FX5U User's Manual (Hardware) <JY997D55301>	Describes the details of hardware of the FX5U CPU module, including input/output specifications, wiring, installation, and maintenance.
MELSEC iQ-F FX5UC User's Manual (Hardware) <JY997D61401>	Describes the details of hardware of the FX5UC CPU module, including input/output specifications, wiring, installation, and maintenance.
MELSEC iQ-F FX5 User's Manual (Application) <JY997D55401> (This manual)	Describes basic knowledge required for program design, functions of the CPU module, devices/labels, and parameters.
MELSEC iQ-F FX5 Programming Manual (Program Design) <JY997D55701>	Describes specifications of ladders, ST, FBD/LD, and other programs and labels.
MELSEC iQ-F FX5 Programming Manual (Instructions, Standard Functions/Function Blocks) <JY997D55801>	Describes specifications of instructions and functions that can be used in programs.
MELSEC iQ-F FX5 User's Manual (Serial Communication) <JY997D55901>	Describes N:N network, MELSEC Communication protocol, inverter communication, non-protocol communication, and predefined protocol support.
MELSEC iQ-F FX5 User's Manual (MODBUS Communication) <JY997D56101>	Describes MODBUS serial communication.
MELSEC iQ-F FX5 User's Manual (Ethernet Communication) <JY997D56201>	Describes the functions of the built-in Ethernet port communication function.
MELSEC iQ-F FX5 User's Manual (SLMP) <JY997D56001>	Explains methods for the device that is communicating with the CPU module by SLMP to read and write the data of the CPU module.
MELSEC iQ-F FX5 User's Manual (Positioning Control) <JY997D56301>	Describes the built-in positioning function.
MELSEC iQ-F FX5 User's Manual (Analog Control) <JY997D60501>	Describes the analog function.
GX Works3 Operating Manual <SH-081215ENG>	System configuration, parameter settings, and online operations of GX Works3.

TERMS

Unless otherwise specified, this manual uses the following terms.

- indicates a variable portion used to collectively call multiple models or versions.

(Example) FX5U-32MR/ES, FX5U-32MT/ES ⇔ FX5U-32M□/ES

- For details on the FX3 devices that can be connected with the FX5, refer to FX5 User's Manual (Hardware).

Terms	Description
■Devices	
FX5	Generic term for FX5U and FX5UC PLCs
FX3	Generic term for FX3S, FX3G, FX3GC, FX3U, and FX3UC PLCs
FX5 CPU module	Generic term for FX5U CPU module and FX5UC CPU module
FX5U CPU module	Generic term for FX5U-32MR/ES, FX5U-32MT/ES, FX5U-32MT/ESS, FX5U-64MR/ES, FX5U-64MT/ES, FX5U-64MT/ESS, FX5U-80MR/ES, FX5U-80MT/ES, and FX5U-80MT/ESS
FX5UC CPU module	Generic term for FX5UC-32MT/D and FX5UC-32MT/DSS
Extension module	Generic term for FX5 extension modules and FX3 function modules
• FX5 extension module	Generic term for I/O modules, FX5 extension power supply module, and FX5 intelligent function module
• FX3 extension module	Generic term for FX3 extension power supply module and FX3 intelligent function module
Extension module (extension cable type)	Input modules (extension cable type), Output modules (extension cable type), Bus conversion module (extension cable type), and Intelligent function modules
Extension module (extension connector type)	Input modules (extension connector type), Output modules (extension connector type), Input/output modules, Bus conversion module (extension connector type), and Connector conversion module (extension connector type)
I/O module	Generic term for input modules, output modules, Input/output modules, and powered input/output modules
Input module	Generic term for Input modules (extension cable type) and Input modules (extension connector type)
• Input module (extension cable type)	Generic term for FX5-8EX/ES and FX5-16EX/ES

Terms	Description
• Input module (extension connector type)	Generic term for FX5-C32EX/D and FX5-C32EX/DS
Output module	Generic term for output modules (extension cable type) and output modules (extension connector type)
• Output module (extension cable type)	Generic term for FX5-8EYR/ES, FX5-8EYT/ES, FX5-8EYT/ESS, FX5-16EYR/ES, FX5-16EYT/ES, and FX5-16EYT/ESS
• Output module (extension connector type)	Generic term for FX5-C32EYT/D and FX5-C32EYT/DSS
Input/output modules	Generic term for FX5-C32ET/D and FX5-C32ET/DSS
Powered input/output module	Generic term for FX5-32ER/ES, FX5-32ET/ES, and FX5-32ET/ESS
Extension power supply module	Generic term for FX5 extension power supply module and FX3 extension power supply module
• FX5 extension power supply module	Different name for FX5-1PSU-5V
• FX3 extension power supply module	Different name for FX3U-1PSU-5V
Intelligent module	The abbreviation for intelligent function modules
Intelligent function module	Generic term for FX5 intelligent function modules and FX3 intelligent function modules
• FX5 intelligent function module	Generic term for FX5 intelligent function modules
• FX3 intelligent function module	Different name for FX3 special function blocks
Simple motion module	Different name for FX5-40SSC-S
Expansion board	Generic term for board for FX5U CPU module
• Communication board	Generic term for FX5-232-BD, FX5-485-BD, and FX5-422-BD-GOT
Expansion adapter	Generic term for adapter for FX5 CPU module
• Communication adapter	Generic term for FX5-232ADP and FX5-485ADP
• Analog adapter	Generic term for FX5-4AD-ADP and FX5-4DA-ADP
Bus conversion module	Generic term for Bus conversion module (extension cable type) and Bus conversion module (extension connector type)
• Bus conversion module (extension cable type)	Different name for FX5-CNV-BUS
• Bus conversion module (extension connector type)	Different name for FX5-CNV-BUSC
Battery	Different name for FX3U-32BL
SD memory card	Generic term for NZ1MEM-2GBSD, NZ1MEM-4GBSD, L1MEM-2GBSD and L1MEM-4GBSD SD memory cards Abbreviation of Secure Digital Memory Card. Device that stores data using flash memory.
Peripheral device	Generic term for engineering tools and GOTs
GOT	Generic term for Mitsubishi Graphic Operation Terminal GOT1000 and GOT2000 series
■Software packages	
Engineering tool	The product name of the software package for the MELSEC programmable controllers
GX Works3	The product name of the software package, SWnDND-GXW3, for the MELSEC programmable controllers (The 'n' represents a version.)
■Manuals	
User's manual	Generic term for separate manuals
• User's manual (Startup)	Abbreviation of MELSEC iQ-F FX5 User's Manual (Startup)
• FX5 User's manual (Hardware)	Generic term for MELSEC iQ-F FX5U User's Manual (Hardware) and MELSEC iQ-F FX5UC User's Manual (Hardware)
• FX5U User's manual (Hardware)	Abbreviation of MELSEC iQ-F FX5U User's Manual (Hardware)
• FX5UC User's manual (Hardware)	Abbreviation of MELSEC iQ-F FX5UC User's Manual (Hardware)
• User's manual (Application)	Abbreviation of MELSEC iQ-F FX5 User's Manual (Application)
Programming manual (Program Design)	Abbreviation of MELSEC iQ-F FX5 Programming Manual (Program Design)
Programming manual (Instructions, Standard Functions/Function Blocks)	Abbreviation of MELSEC iQ-F FX5 Programming Manual (Instructions, Standard Functions/Function Blocks)
Communication manual	Generic term for MELSEC iQ-F FX5 User's Manual (Serial Communication), MELSEC iQ-F FX5 User's Manual (MODBUS Communication), MELSEC iQ-F FX5 User's Manual (Ethernet Communication), and MELSEC iQ-F FX5 User's Manual (SLMP)
• Serial communication manual	Abbreviation of MELSEC iQ-F FX5 User's Manual (Serial Communication)
• MODBUS communication manual	Abbreviation of MELSEC iQ-F FX5 User's Manual (MODBUS Communication)
• Ethernet communication manual	Abbreviation of MELSEC iQ-F FX5 User's Manual (Ethernet Communication)
• SLMP manual	Abbreviation of MELSEC iQ-F FX5 User's Manual (SLMP)
Positioning manual	Abbreviation of MELSEC iQ-F FX5 User's Manual (Positioning Control)
Analog manual	Abbreviation of MELSEC iQ-F FX5 User's Manual (Analog Control)

MEMO

This part consists of the following chapters.

1 PROGRAM EXECUTION

2 PROCESSING OF OPERATIONS ACCORDING TO CPU MODULE OPERATION STATUS

3 CPU MODULE MEMORY CONFIGURATION

1 PROGRAM EXECUTION

1.1 Scan Configuration

The configuration of the scan of the CPU module is explained below.

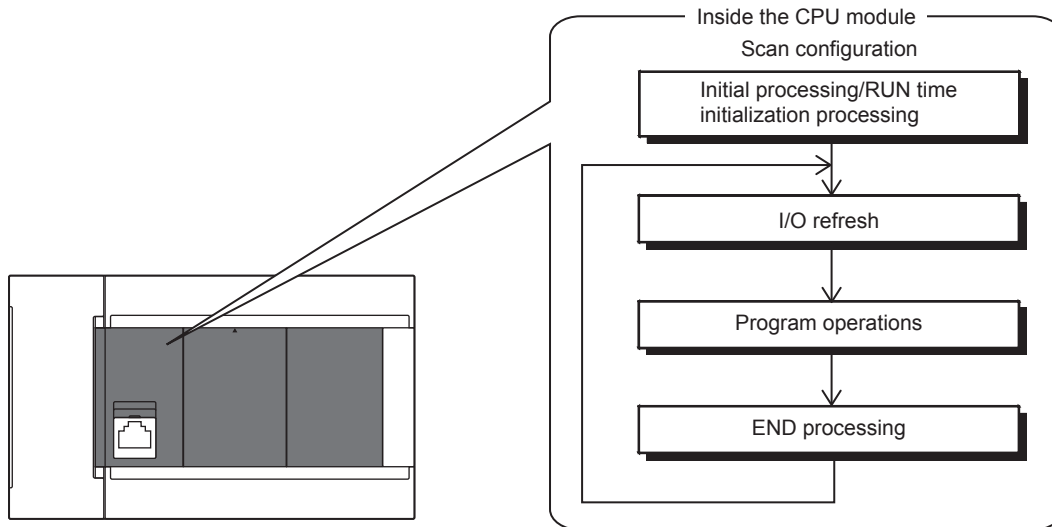

Initial processing and initialization processing in RUN mode

Initial processing according to CPU module status and initialization processing in the RUN status are explained below.

○: Execute, ×: Do not execute

Processing item	CPU module status			
	At power ON	At reset	STOP→RUN after write to PLC ^{*1}	At STOP→RUN
Initialization of input/output module	○	○	×	×
Boot from SD memory card	○	○	×	×
CPU parameter check	○	○	○	×
System parameter check	○	○	○	×
Initialization of device/label outside latch range (bit device: OFF, word device: 0)	○	○	×	×
Assignment of I/O numbers of input/output module	○	○	○	×
Setting of module parameters	○	○	×	×
Setting of device	○	○	○	○

*1 Indicates an instance of power OFF→ON or setting to RUN status without a reset after modifying parameters or program in STOP status.

I/O refresh

Execute I/O refresh before starting program operations.

- Input ON/OFF data input from input module/intelligent function module to CPU module
- Output ON/OFF data input from CPU module to output module/intelligent function module



When executing constant scan, I/O refresh is executed after the constant scan waiting time ends.

Program operations

Step 0 of each program up to the END/FEND instruction is executed according to program settings. This program is called the "main routine." Main routine programs can be divided into subroutines. ( Page 29 Subroutine program)

END processing

END processing involves the following processes:

- Refreshing of network modules
- Refreshing of intelligent function modules
- Instruction termination processing
- Device/label access service processing
- Resetting of the watchdog timer
- Self-diagnostic processing
- Setting of values to special relays/special registers (set timing: when END processing is executed)

1.2 Scan Time

The CPU module repeats the following processing. The scan time is the sum total of each process and execution time.

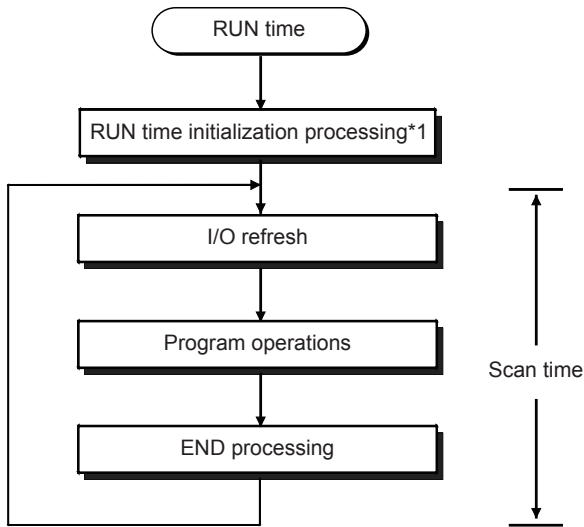

*1 This process is included in the initial scan time.

Initial scan time

This refers to the initial scan time when the CPU module is in the RUN mode.

How to check the initial scan time

The initial scan time can be checked by the following information:

- Value stored in SD518 (initial scan time (ms)), SD519 (initial scan time (μs))
- Program list monitor (📖GX Works3 Operating Manual)

Monitoring the initial scan time

The initial scan time is monitored by the initial scan time execution monitor time. (👉 5 SCAN MONITORING FUNCTION)

■Initial scan time execution monitor time precautions

- Set an initial execution monitor time longer than the execution time of the initial scan time. An error occurs when the initial scan time exceeds the set initial execution monitor time.
- The measurement error margin of the initial scan execution monitor time is 10 ms. For example, if the initial execution monitor time (t) is set to 100 ms, an error occurs in the initial scan time in the range $100\text{ ms} < t < 110\text{ ms}$ range.

1.3 Program Execution Sequence

When the CPU module enters the RUN status, the programs are executed successively according to the execution type of the programs and execution order setting.

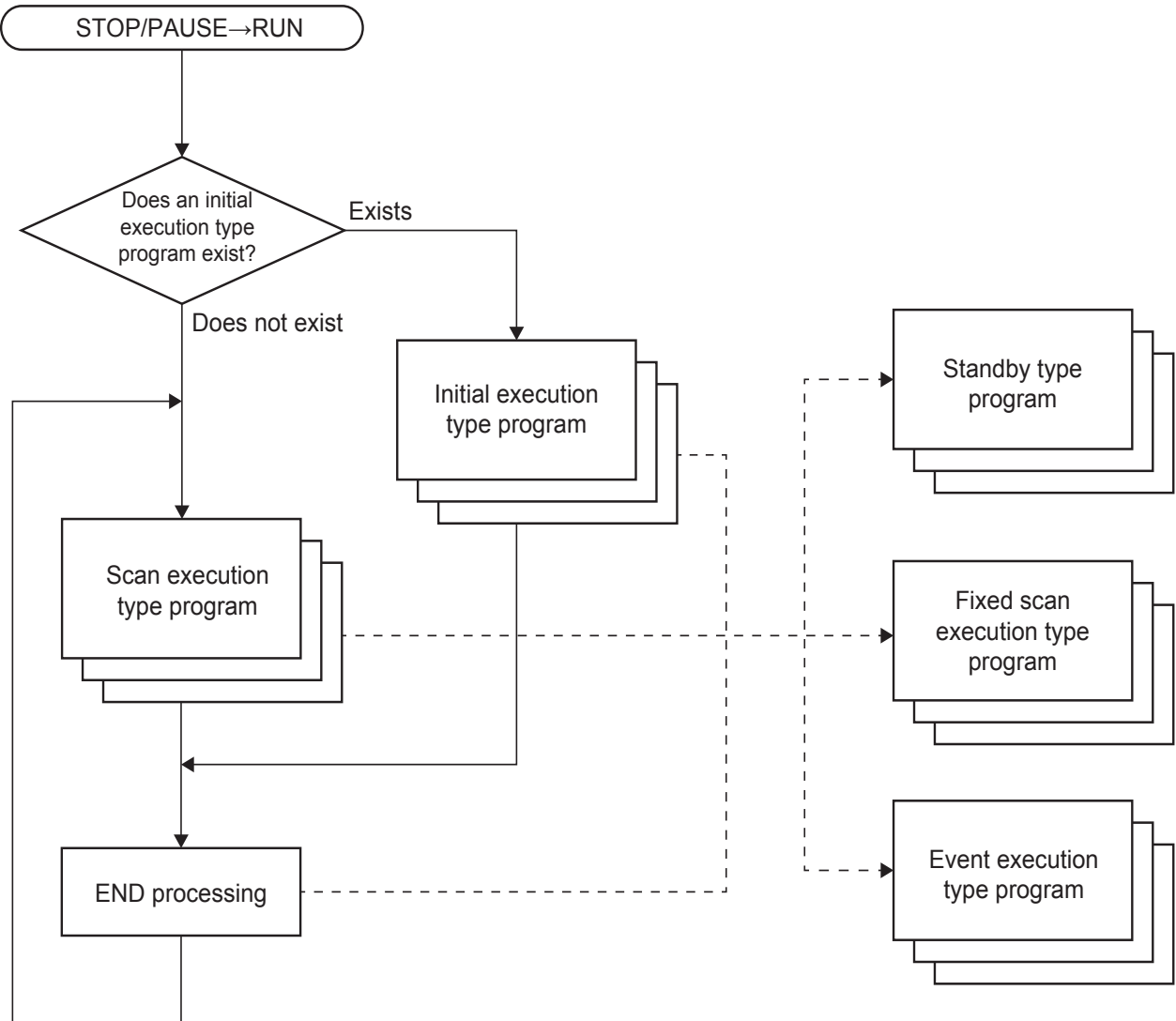

Point

When the execution type of the programs is the same, the programs are executed in the order in which the execution order was set.

1.4 Execution Type of Program

Set the program execution conditions.

Initial execution type program

This program type is executed only once when the CPU module changes from the STOP/PAUSE to the RUN status. This program type is used for programs, that do not need to be executed from the next scan once they are executed, like initial processing on an intelligent function module.

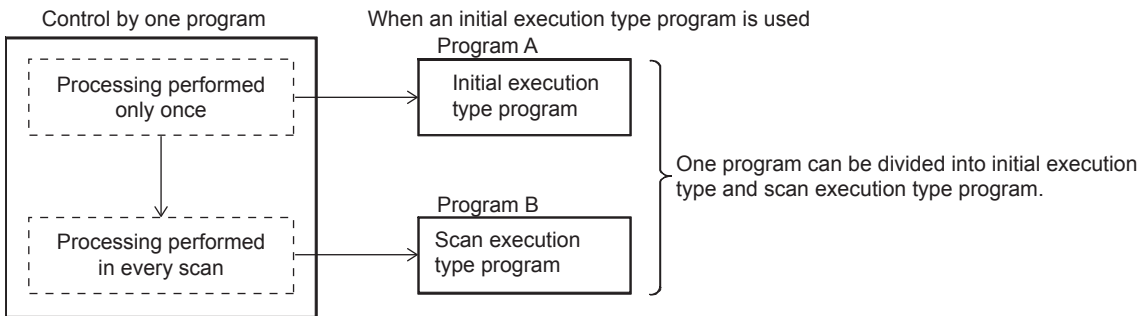

Also, the execution time of initial execution type programs is the same as the initial scan time.

When multiple initial execution type programs are executed, the execution time of the initial execution type programs becomes the time until execution of all initial execution type programs is completed.

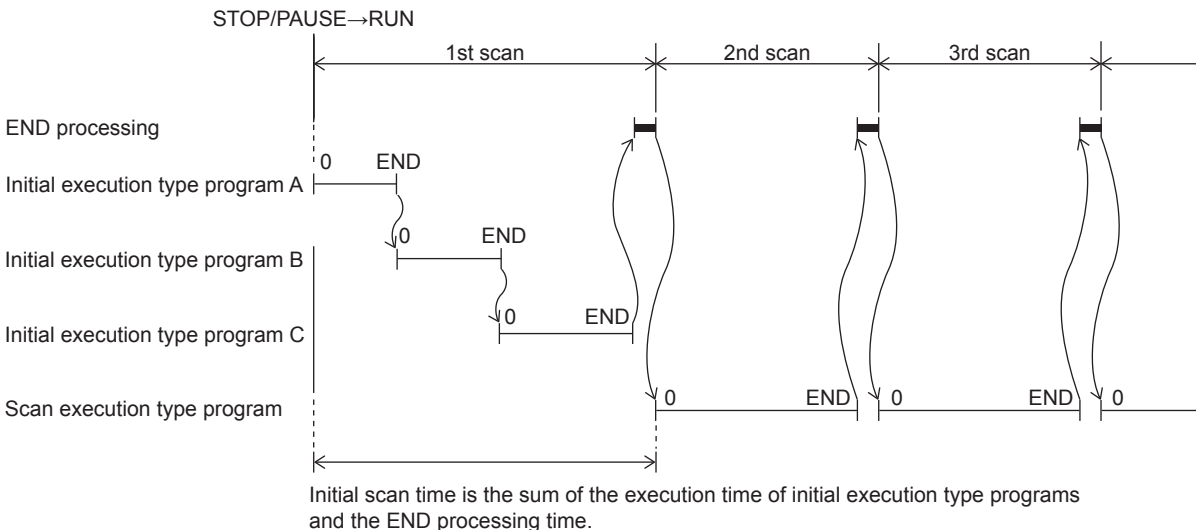

Precautions

The precautions for initial execution type programs are explained below.

■Restrictions in programming

With initial execution type programs, do not use instructions that require several scans to complete execution (instructions for which completion devices exist).

Ex.

e.g. RBFM and WBFM instructions

Scan execution type program

This program type is executed only once per scan from the scan following the scan where an initial execution type program was executed.

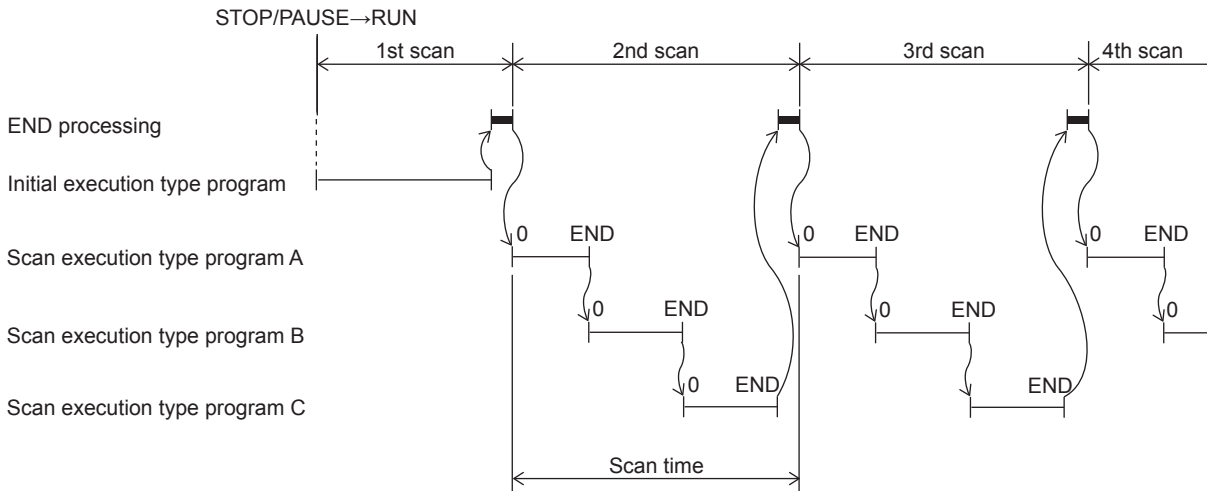

When multiple scan execution type programs are executed, the execution time of the scan execution type programs becomes the time until execution of all scan execution type programs is completed. Note, however, that when an program/event execution type program is executed before a scan execution type program is completed, the execution time of these programs is included in the scan time.

Fixed scan execution type program

An interrupt program which is executed at a specified time interval. Different from the normal interrupt program, this type of program does not require interrupt pointer (I) and IRET instruction to be written (pointer is assigned by parameter). Execution is performed by program file basis.

You can use 4 files of fixed scan execution type programs at the maximum.

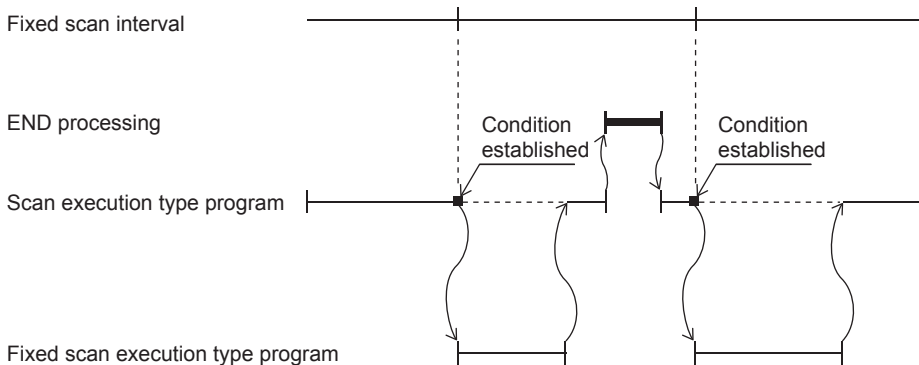

Point

To execute a fixed scan execution type program, the EI instruction must be used to enable interrupts.

Make the following settings for fixed scan execution type program in CPU parameter.

- Interrupt pointer setting (Interrupt from internal timer: I28 to I31)
- Fixed scan interval setting

Interrupt pointer setting

The interrupt pointer (Interrupt from internal timer: I28 to I31) assigned to a fixed scan execution type program is set up.

Navigation window ⇒ [Parameter] ⇒ [FX5UCPU] ⇒ [CPU Parameter] ⇒ "Program Setting" ⇒ "Program Setting" ⇒ "Detailed Setting" ⇒ "Detailed Setting Information"

1. Open program setting screen.
2. Set type as fixed scan.
3. Specify interrupt pointer.

Window

Execute Order	Program Name	Execution Type	
		Type	Detailed Setting Information
1	MAIN	Scan	
2	MAIN1	Fixed Scan	Interrupt:I31:10 ms
3			
4			
5			

Displayed items

Item	Description	Setting range	Default
Interrupt Pointer	Set the interrupt pointer which is assigned to fixed scan execution type program.	<ul style="list-style-type: none"> • I28 • I29 • I30 • I31 	I31
Specified Time Intervals	Fixed scan interval setting value is displayed. Setup is performed on another screen. (Page 22 Fixed scan interval setting)	—	—

Fixed scan interval setting

Sets the fixed scan interval setting of the fixed scan execution type program. (It is the same as setting for interrupt from internal timer.)

Navigation window ⇒ [Parameter] ⇒ [FX5UCPU] ⇒ [CPU Parameter] ⇒ "Interrupt Settings" ⇒ "Fixed Scan Interval Setting"

Window

Item	Setting
Fixed Scan Interval Setting	
Interrupt Setting from Internal Timer	
I28	100 ms
I29	40 ms
I30	20 ms
I31	10 ms

Displayed items

Item	Description	Setting range	Default	
Interrupt Setting from Internal Timer	I28	Sets the execution interval of I28.	1 to 60000 ms (1 ms units)	100 ms
	I29	Sets the execution interval of I29.	1 to 60000 ms (1 ms units)	40 ms
	I30	Sets the execution interval of I30.	1 to 60000 ms (1 ms units)	20 ms
	I31	Sets the execution interval of I31.	1 to 60000 ms (1 ms units)	10 ms

Action when the execution condition is satisfied

Performs the following action.

■If the execution condition is satisfied before the interrupt is enabled by the EI instruction

The program enters the waiting status and is executed when the interrupt is enabled. Note that if the execution condition for this fixed scan execution type program is satisfied more than once during the waiting status, the program is executed only once when the interrupt is enabled.

■When there are two or more fixed scan execution type programs

When the specified time intervals expire in the same timing, the programs are executed in order according to the priority (I31 > I30 > I29 > I28) of the periodic interrupt pointer.

■If another or the same execution condition is satisfied while the fixed scan execution type program is being executed

Operates according to the fixed scan execution mode setting.

■If the execution condition is satisfied while the interrupt is disabled by the system

Operates according to the fixed scan execution mode setting.

■When an interrupt is generated during a standby while executing constant scan

Executes the fixed scan execution type program.

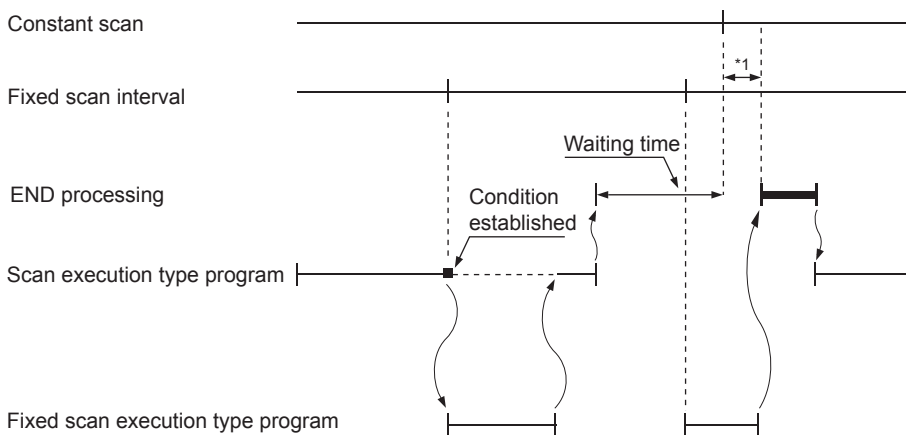

*1 If processing does not finish during the waiting time, the scan time is extended.

■If another interrupt occurs while the fixed scan execution type program is being executed

If an interrupt program is triggered while the fixed scan execution type program is being executed, the program operates in accordance with the interrupt priority.

Processing when the fixed scan execution type program starts

The same processing as when the interrupt program starts. (☞ Page 34 Processing at startup of interrupt program)

Fixed scan execution mode

If execution condition for a fixed scan execution type program and fixed cycle interrupt (I28 to I31) based on the internal timer of the CPU module is satisfied while interruption is disabled, the operation of the program execution after interruption becomes allowed is specified. However, if execution condition is satisfied while interruption is set to be disabled because of a DI instruction or the like, this is out of the scope of the fixed scan execution mode.

Point

"Interrupts disabled" refers to the following:

- A program having an interrupt priority higher than or the same as the corresponding program is currently being executed.
- The corresponding program is currently being executed.
- Program execution is currently at a part in which interrupts are disabled by the system.

■ Operation in the fixed scan execution mode

This section describes the operation which can be performed in the fixed scan execution mode.

- Execution Count Takes Priority

The program is executed for all the pending number of executions so that it can be executed the same number of times as execution condition was satisfied.

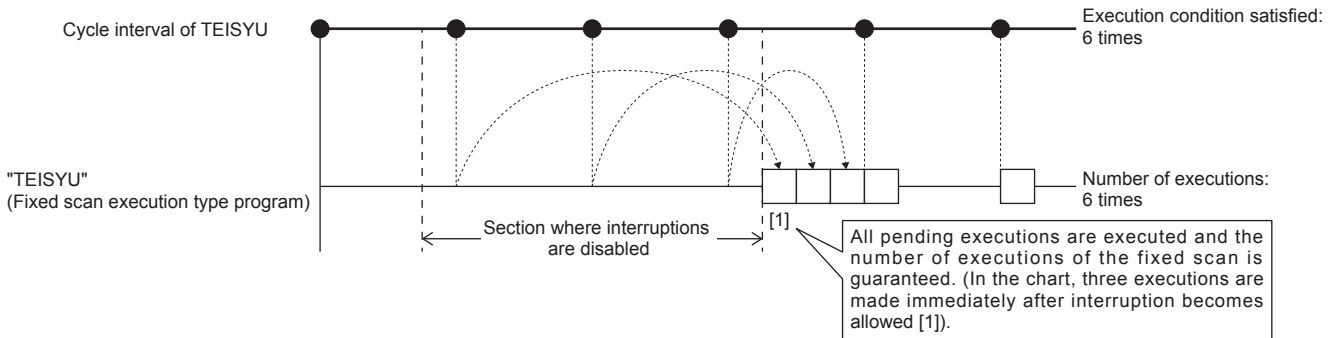

- Precede Fixed Scan

When the waiting for execution, one execution is made when interrupt becomes allowed. Even if execution condition was satisfied twice or more, only one execution is performed.

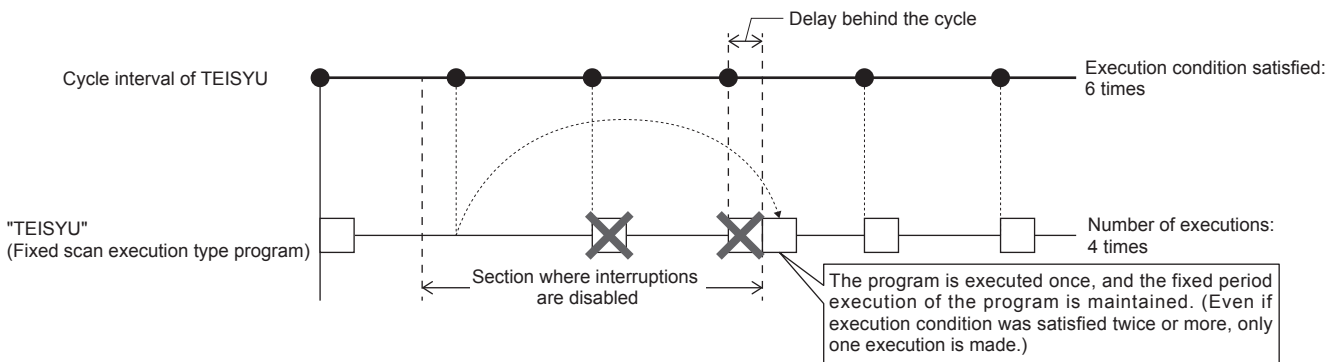

■ Fixed scan execution mode setting

Use the fixed scan execution mode setting.

Navigation window ⇒ [Parameter] ⇒ [FX5UCPU] ⇒ [CPU Parameter] ⇒ "Interrupt Settings" ⇒ "Fixed Scan Execution Mode Setting"

Window

Item	Setting
Fixed Scan Execution Mode Setting	
Fixed Scan Execution Mode	Precede Fixed Scan

Displayed items

Item	Description	Setting range	Default
Fixed Scan Execution Mode	For Precede Fixed Scan, the periodicity of the program is maintained. For Execution Count Takes Priority, the program is executed for all pending number of executions.	<ul style="list-style-type: none"> • Precede Fixed Scan • Execution Count Takes Priority 	Precede Fixed Scan

Event execution type program

Execution of this program type is triggered by a user-specified event. (☞ Page 25 Trigger type)

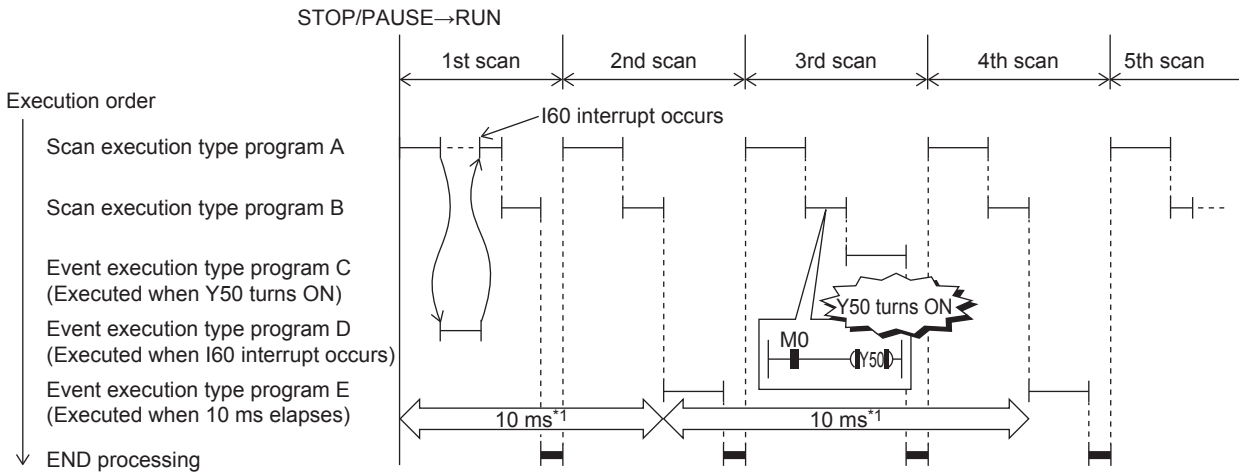

*1 Measurement of elapsed time is 10 ms or more because it is determined depending on the scan time.

Trigger type

Triggers for event execution type programs are explained below. (☞ Page 27 Trigger setting)

■ Generation of interrupt by interrupt pointer (I)

The program is executed once, immediately, when a specified interrupt cause is generated. An interrupt pointer label can be appended by adding the FEND instruction to a different program, and the program description partitioned by the IRET instruction can be turned into an exclusive program.

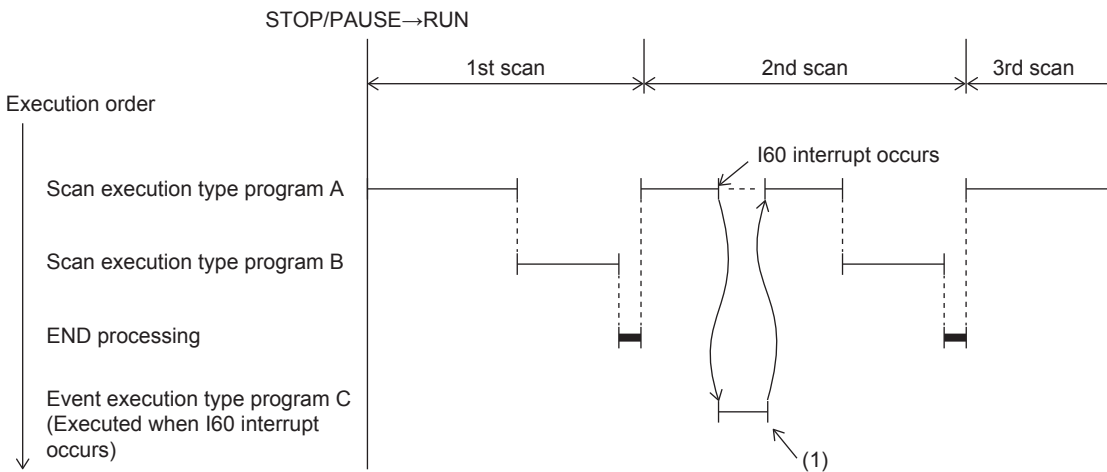

(1) Event execution type program C is executed immediately when the specified event is generated.

• Specifiable interrupt pointer (I)

Specifiable interrupt pointers are I0 to I15, I16 to I23, and I50 to I177.



Execution conditions for the event execution type program which is triggered by interrupt occurred by the interrupt pointer (I) are the same as those for general interrupt programs. (☞ Page 31 Operation when an interrupt is generated)

■Bit data ON (TRUE)

When it is the turn of the corresponding program to be executed, the program is executed if the specified bit data is ON. This eliminates the need for creating a program for monitoring triggers in a separate program.

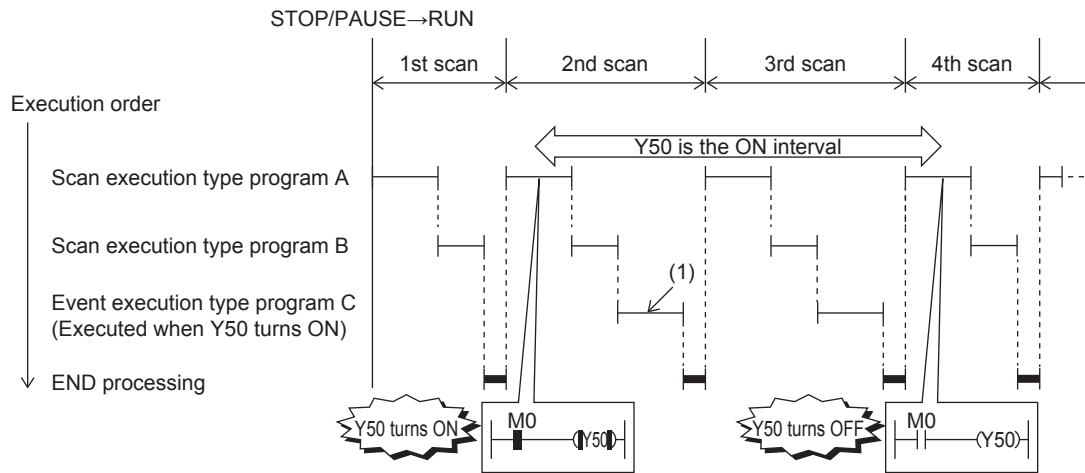

(1) The program is executed if Y50 is ON when it is the turn of event execution type program C to be executed.

Applicable devices are as follows.

Item	Description	
Device*1	Bit device	X (DX), Y, M, L, F, SM, B, SB
	Bit specification in word device	D, SD, W, SW, R, U□IG□

*1 Indexed devices cannot be specified.

■Elapsed time

The program is executed once when it is the turn of the corresponding program to be executed first after the CPU module is run and the specified time has elapsed. For second execution onwards, the time is re-calculated from the start of the previous event execution type program. When it is the turn of the corresponding program to be executed first after specified time has elapsed, program execution is repeated. Output (Y) currently used in the corresponding program and the current values of timer (T) can be cleared at the next scan following execution of the corresponding program. This will not be always executing an interrupt at a constant cycle but can be used when executing a specified program after a specified time has elapsed.

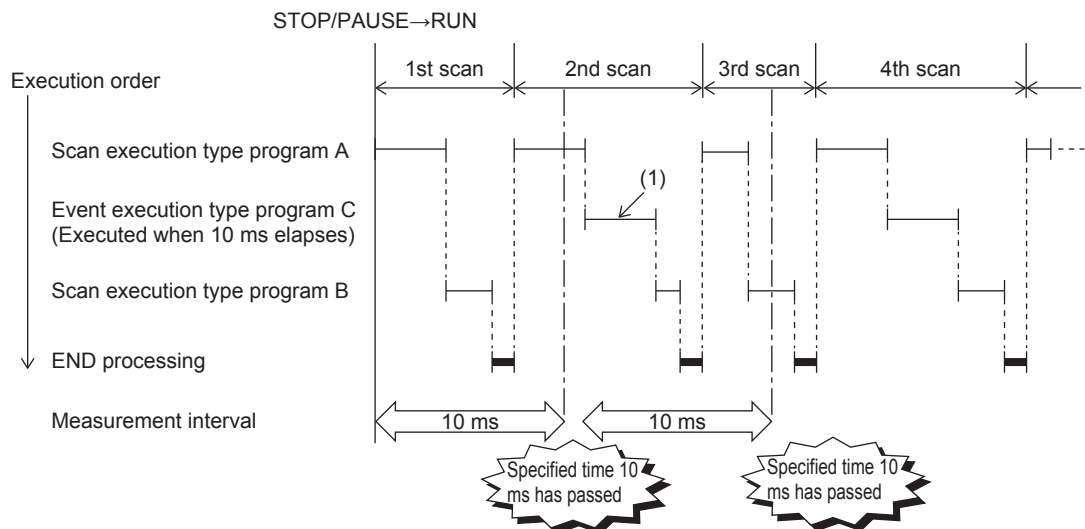

(1) When it is the turn of the first execution after the specified time has elapsed, event execution type program C is executed.

Point

Output and timer current values are not cleared even when the program is set so that output and timer current values are cleared, if the scan time is longer than the elapsed time set value.

Trigger setting

Use the event execution type detail setting.

Navigation window ⇒ [Parameter] ⇒ [FX5UCPU] ⇒ [CPU Parameter] ⇒ "Program Setting"

Operating procedure

"Program Setting" window

Item	Setting
Program Setting	<Detailed Setting>

"Detailed Setting" window

Execute Order	Program Name	Execution Type	
		Type	Detailed Setting Information
1	MAIN	Event	Bit ON/Do Not Clear
2			

"Event Execution Type Detailed Setting" window

Item	Setting
Trigger Type	ON of Bit Data (TRUE)
Interruption Occurrence	
ON of Bit Data (TRUE)	
Clear Output and Current Value of Timer	Do Not Clear
Passing Time	
Unit	ms
Clear Output and Current Value of Timer	Do Not Clear

1. Click "Detailed Setting" on the Program Setting.
2. Select the program name and set the execution type to "Event".
3. Click "Detailed Setting Information".
4. Set the trigger type to execute the event execution type program.

Displayed items

Item	Description	Setting range	Default
Interruption Occurrence	Sets the interrupt pointer used as the trigger.	I0 to I23, I50 to I177	—
ON of Bit Data (TRUE)	Sets the device used as the trigger.	☞ Page 26 Bit data ON (TRUE)	—
Passing Time	Sets the elapsed time.	<ul style="list-style-type: none"> When "ms" is selected: 1 to 65535 ms (in 1 ms units) When "s" is selected: 1 to 65535 s (in 1 s units) 	—

Point

When "Clear Output and Current Value of Timer" is enabled together with "ON of Bit Data (TRUE)" or "Passing Time", the current values of the output (Y) and timer (T) of this program can be cleared at the first execution turn of this program that comes after the trigger turns OFF.

Stand-by type program

This program is executed only when there is an execution request.

Saving programs in library

Subroutine programs or interrupt programs are saved as standby type programs so that they can be used when controlled separately from the main routine program. Multiple subroutine programs and interrupt programs can be created in one standby type program.

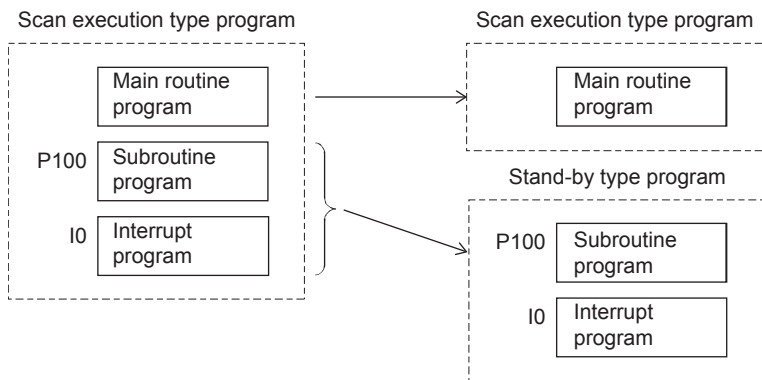

How to execute

Execute standby type programs as follows.

- Create sub-routine programs and interrupt programs in the standby type program which is called up by a pointer, etc. or when an interrupt is generated.

1.5 Program Type

Programs that use pointers (P) or interrupt pointers (I) are explained below.

Subroutine program

This is the program from pointer (P) up to the RET instruction. Subroutine programs are executed only when they are called by the CALL instruction. Pointer type labels also can be used instead of pointers (P). The applications of subroutine programs are as follows:

- By grouping programs that are executed multiple times in one scan into a single subroutine program, the number of steps in the entire program can be reduced.
- A program that is executed only under certain conditions can be saved as a subroutine program which shortens the scan time proportionately.

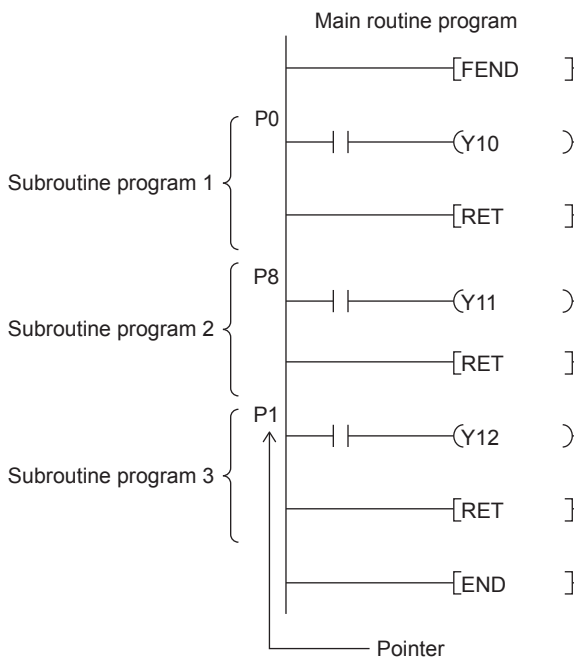

Point

- Subroutine programs can also be managed as separate programs by turning them into standby type programs. (Page 28 Stand-by type program)
- Pointers need not be programmed starting with the smallest number.

Precautions

- The precautions when using subroutine programs are explained below.
- Do not use timers (T, ST). Note, however, that timers can be used when a timer coil (OUT T□ instruction) is always executed only once in one scan.
 - An error occurs when program execution returns to the call source program and the program is terminated without using the RET instruction.
 - An error occurs when there is no pointer (P) or pointer type global label in FB or FUN.

Interrupt program

This is the program from interrupt pointer (I) up to the IRET instruction.

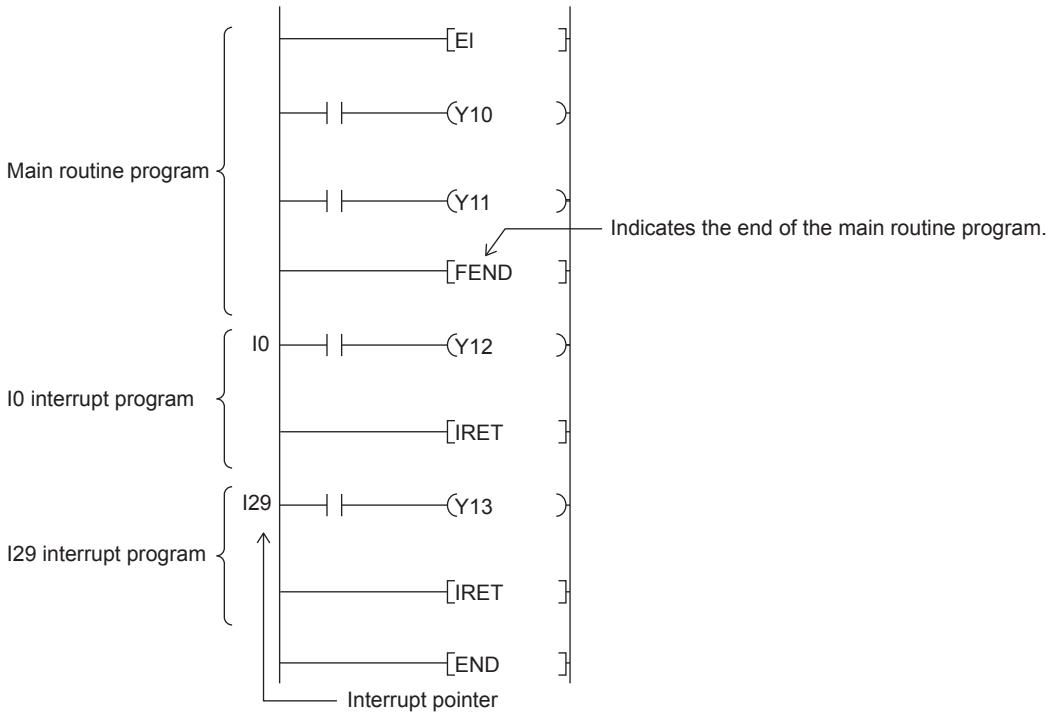

When an interrupt is generated, the interrupt program corresponding to that interrupt pointer number is executed. Note, however, that interrupt enabled status must be set with the EI instruction before executing the interrupt program.

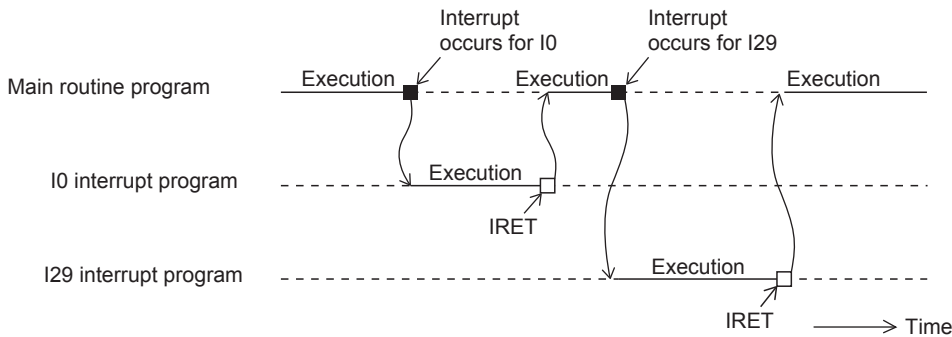

Point 🔍

- Only one interrupt program can be created with one interrupt pointer number.
- Interrupt pointers need not be programmed starting with the smallest number.
- Interrupt programs can also be managed as separate programs by turning them into standby type programs. (📖 Page 28 Stand-by type program)

Operation when an interrupt is generated

Operation when an interrupt is generated is explained below.

■If an interrupt cause occurs when interrupt is disabled (DI)

The interrupt that was generated is stored, and the stored interrupt program is executed the moment that the status changes to interrupt enabled. An interrupt is stored only once even if the same interrupt is generated multiple times. Note, however, that all interrupts cause are discarded when interrupt disable is specified by the IMASK and SIMASK instructions.

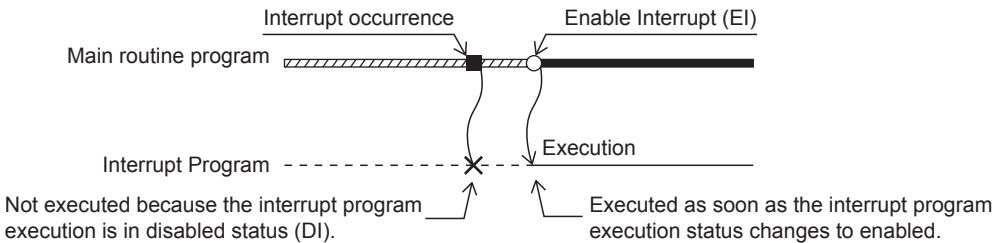

■When an interrupt cause is generated by a PAUSE status

The interrupt program is executed the moment that the CPU module changes to the RUN status and the status changes to interrupt enabled. An interrupt is stored only once when the same interrupt is generated multiple times before the CPU module changes to the RUN status.

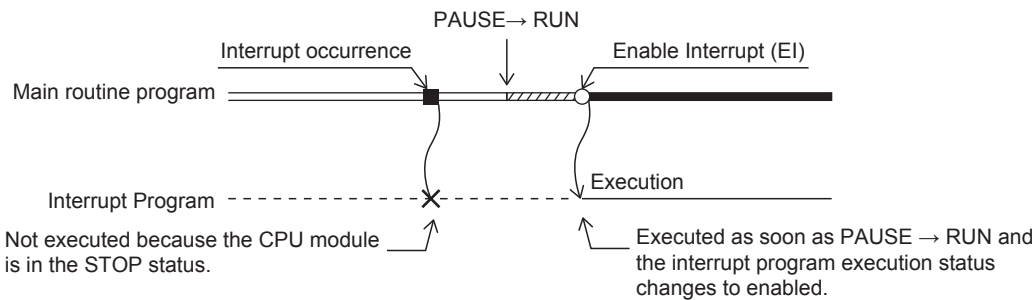

■When multiple interrupts are generated at the same time while in an interrupt enabled status

Interrupt programs are executed in order starting from program having the highest priority. Interrupt programs also run in order of priority rank when multiple interrupt programs having the same priority are generated simultaneously.

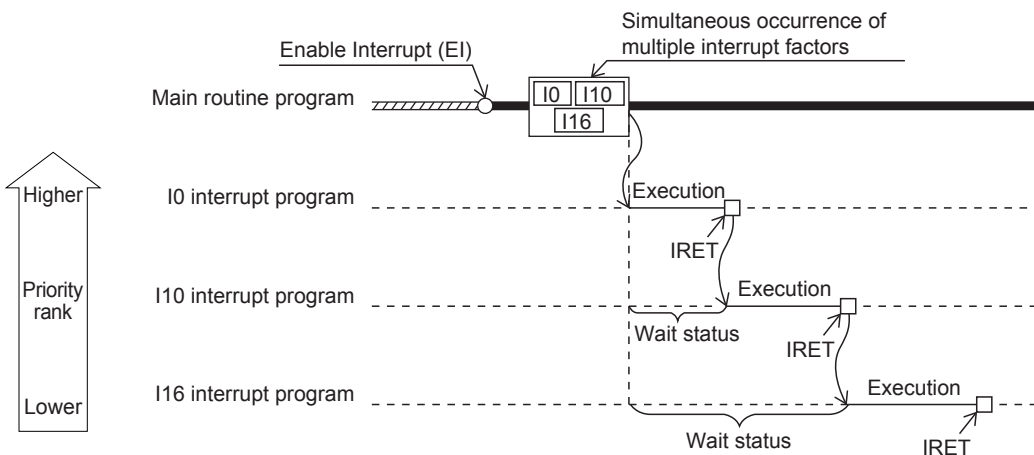

■When an interrupt is generated during standby while executing constant scan

The interrupt program for that interrupt is executed.

■When another interrupt is generated during execution of the interrupt program

If an interrupt such as a fixed scan execution type program (including an interrupt which triggers the event execution type program) is triggered while an interrupt program is being executed, the program operates in accordance with the interrupt priority.

■ If an interrupt cause with the same or a lower priority occurs while the interrupt program is being executed

- For I0 to I23 and I50 to I177

The occurred interrupt cause is memorized, and the interrupt program corresponding to the factor will be executed after the running interrupt program finishes. Even if the same interrupt factor occurs multiple times, it will be memorized only once.

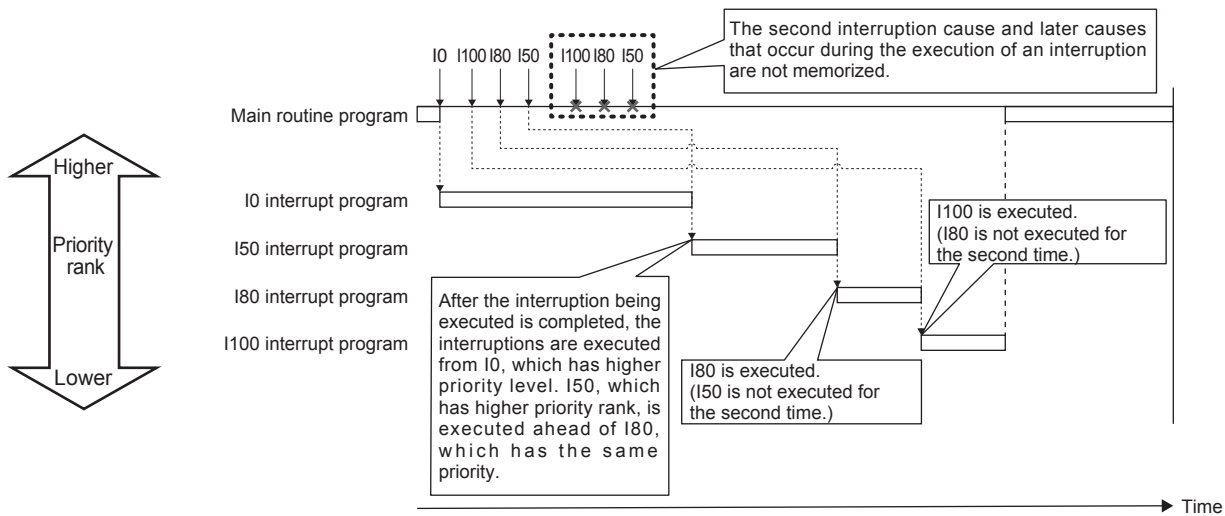

- For I28 to I31

The interrupt cause that occurred is memorized, and the interrupt program corresponding to the cause will be executed after the running interrupt program finishes. If the same interrupt cause occurs multiple times, it will be memorized once but operation at the second and later occurrences depends on setting of the fixed scan execution mode. (Page 23 Fixed scan execution mode)

When "Execution Count Takes Priority" is enabled, the interrupt program corresponding to the memorized interrupt causes will be executed after the running interrupt program finishes. When "Precede Fixed Scan" is enabled, the second and later occurrences will not be memorized.

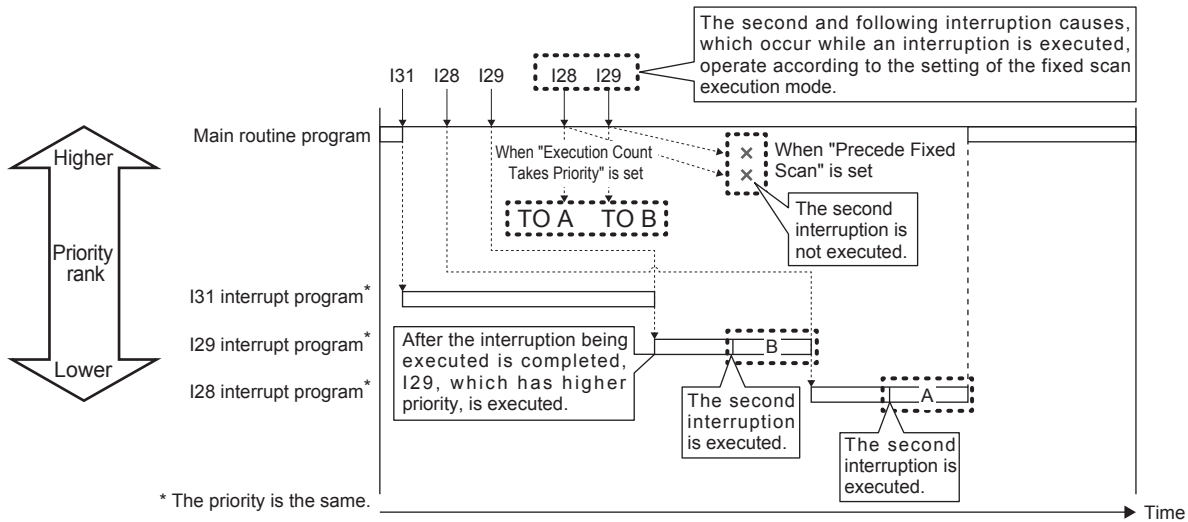

■ If the same interrupt cause occurs while the interrupt program is being executed

- For I0 to I23 and I50 to I177

The interrupt cause that occurred is memorized, and the interrupt program corresponding to the cause will be executed after the running interrupt program finishes. Even if the same interrupt cause occurs multiple times, it will be memorized only once.

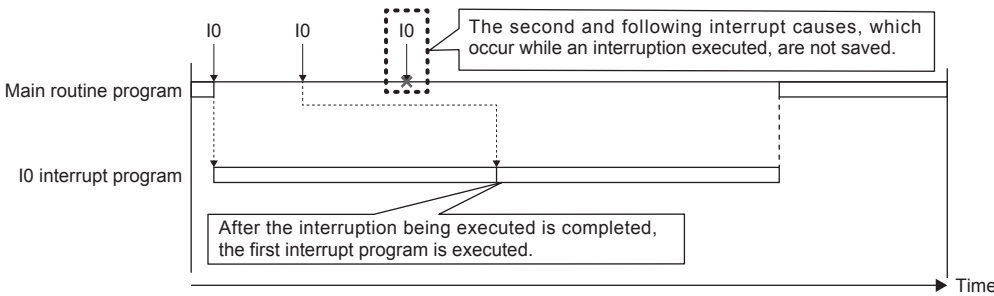

- For I28 to I31

The interrupt cause is memorized, and the interrupt program corresponding to the cause will be executed after the running interrupt program finishes. If the same interrupt factor occurs multiple times, it will be memorized once but operation at the second and later occurrences depends on setting of the fixed scan execution mode. (Page 23 Fixed scan execution mode)

When "Execution Count Takes Priority" is enabled, the interrupt program corresponding to the memorized interrupt cause will be executed after the running interrupt program finishes. When "Precede Fixed Scan" is enabled, the second and later occurrences will not be memorized.

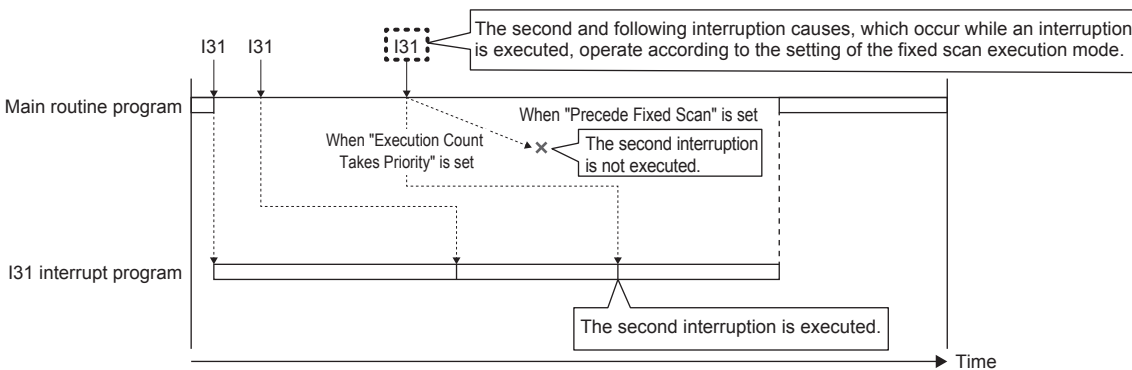

Setting the interrupt cycle

Set the interrupt cycle of interrupts I28 to I31 using the internal timer of the interrupt pointer.

Navigation window ⇒ [Parameter] ⇒ [FX5UCPU] ⇒ [CPU Parameter] ⇒ "Interrupt Settings" ⇒ "Fixed Scan Interval Setting"

Window

Item	Setting
Fixed Scan Interval Setting	
Interrupt Setting from Internal Timer	
I28	100 ms
I29	40 ms
I30	20 ms
I31	10 ms

Displayed items

Item	Description	Setting range	Default	
Interrupt Setting from Internal Timer	I28	Sets the execution interval of I28.	1 to 60000 ms (1 ms units)	100 ms
	I29	Sets the execution interval of I29.	1 to 60000 ms (1 ms units)	40 ms
	I30	Sets the execution interval of I30.	1 to 60000 ms (1 ms units)	20 ms
	I31	Sets the execution interval of I31.	1 to 60000 ms (1 ms units)	10 ms

Processing at startup of interrupt program

Processing is as follows when an interrupt program is started up.

- Purge/restore of index registers (Z, LZ)

■Purge/restore of index registers (Z, LZ)

When an interrupt program is started up, the values of the index registers (Z, LZ) in the currently executing program are purged, and those values are handed over to the interrupt program. Then, when an interrupt program is terminated, the purged values are restored to the currently executing program.

Precautions

The precautions for interrupt programs are explained below.

■Restrictions in programming

- The PLS/PLF instructions execute OFF processing at the scan following instruction execution. ON devices remain ON until the interrupt program runs again and the instruction is executed.
- Only a routine timer can be used in an interrupt program. Timers (T, ST) cannot be used.

■Splitting of data

Processing may be interrupted during instruction execution and an interrupt programs can be executed. Accordingly, splitting of data might occur if the same devices are used by both the interrupt program and the program that is aborted by the interrupt. Implement the following preventive measure.

- Set instructions that will result in inconsistencies if interrupted to "interrupt disabled" using the DI instruction.
- When using bit data, ensure that the same bit data is not used by both the interrupt program and the program that is aborted by the interrupt.

■Interrupt precision is not improved

If interrupt precision is not improved, this might be remedied by implementing the following:

- Give higher priority to the interrupt that needs higher precision.
- Use an interrupt pointer with high interrupt priority order.
- Recheck the section of interruption disabled.

2 PROCESSING OF OPERATIONS ACCORDING TO CPU MODULE OPERATION STATUS

The CPU module has three operation statuses as follows:

- RUN status
- STOP status
- Paused

Processing of operations on the CPU module in each status is explained below.

Processing of operations in RUN status

In the RUN mode, operations in the sequence program are executed repeatedly in order step 0→END (FEND) instruction→step 0.

■Output when CPU module enters RUN mode

Operation results are output after the sequence program is executed for the duration of one scan.

The device memory other than the output (Y) holds the state immediately before the RUN state. However, if device initial value is set up, this initial value is set.

■Processing time until start of operation

The processing time from the CPU module switching from STOP→RUN up to start of execution of operations in the sequence program fluctuates according to the system configuration and parameter settings. (Normally, this time is within one second.)

Processing of operations in STOP status

In the STOP status, execution of operations in the sequence program is stopped by the RUN/STOP/RESET switch or a remote stop. The CPU module also enters the STOP status when a stop error occurs.

■Output when CPU module enters STOP status

When the CPU module enters the STOP status, all output points (Y) turn OFF. For device memory other than outputs (Y), non-latch devices are cleared and latch devices are held.

However, when SM8033 is on and CPU module switches RUN→STOP, it is possible to hold an output state and the current value of a device.

Processing of operations in paused status

In a paused status, execution of operations in the sequence program is stopped after one scan execution but with outputs and device memory states held, by a remote pause.

Processing of operations by the CPU module during switch operations

Processing of operations by the CPU module is as follows according to the RUN or STOP mode.

RUN/STOP status	Processing of operations by CPU module			
	Processing of operations in sequence program	External output	Device memory	
			Other than Y	Y
RUN→STOP	The program is executed up to the END instruction and then stops.	All output points turn OFF.	Latch devices are held, and non-latch devices are cleared.	All output points turn OFF.
STOP→RUN	Program execution starts from step 0.	Operation results are output after the PLC is run for the duration of one scan.	The states of device memories immediately before the CPU module entered the RUN mode are held. Note, however, that when device initial values are set, the device initial values are set.	Operation results are output after the PLC is run for the duration of one scan.

Point

The CPU module performs the following processing regardless of RUN or STOP status or paused status.

- Refreshing of input/output modules
- Automatic refreshing of intelligent function modules
- Self-diagnostic processing
- Device/label access service processing
- Setting of values to special relays/special registers (set timing: when END processing is executed)

For this reason, the following operations can be performed even in the STOP status or paused status:

- Monitoring of I/O or test operations by the engineering tool
- Reading/writing from external device using SLMP
- N:N Network
- MODBUS RTU slave

3 CPU MODULE MEMORY CONFIGURATION

3.1 Memory Configuration

CPU module memory is explained below.

Memory configuration

The configuration of CPU module memory is explained below.

Memory type		Application
CPU built-in memory	Data memory	The following files are stored in this memory: <ul style="list-style-type: none">• Program files, FB files• Restored information files• Parameter files• Files that contain device comments, etc.
	Device/label memory	Data areas for internal devices/labels, etc. are located in this memory.
SD memory card		This is for storing files that contain device comments, etc. and folders and files that are created by SD memory card functions.

Data memory

The following files are stored in data memory.

Category	File type	Max. number of files	Storage area size	Remarks
Program	Program file	32	1 Mbytes	—
	FB files	16 (Up to 15 for user)		—
Restored information	Restored information files	48	1 Mbytes	—
Parameters	Parameter files common to system	1	1 Mbytes	—
	CPU parameter file	1		—
	Module parameter file	1		—
	Remote password	1		—
	Global label setting file	1		—
	Module extension parameter (for protocol setting)	2		—
	Device initial values file	1		—
Comments	Device comment file	1	2 Mbytes	—

Device/label memory

Device/label memory has the following areas.

Area	Storage area size	Application
Device/label memory (standard)	96 Kbytes	R, W, SW, labels, and latch labels can be placed in this memory in variable lengths. R and W can be backed up in the event of a power interruption only when the optional battery is installed. Also, latch label capacity can be increased when the battery is installed.
Device/label memory (fast)	24 Kbytes	Bit devices, T, ST, C, LC, D, Z, LZ, labels, and latch labels can be placed in this memory in variable lengths.
For saving device/label memory	25 Kbytes	This memory is for saving latch devices and devices in fast area that require a latch in the event of a power interruption.

SD memory card

The following files are stored in SD memory card.

Category	File type	Max. number of files	Storage area size	Remarks
Program	Program file	32	1 Mbytes	—
	FB files	16 (Up to 15 for user)		—
Restored information	Restored information files	48	1 Mbytes	—
Parameters	Parameter files common to system	1	1 Mbytes	—
	CPU parameter file	1		—
	Module parameter file	1		—
	Memory card parameter	1		—
	Remote password	1		—
	Global label setting file	1		—
	Module extension parameter (for protocol setting)	2		—
	Initial device value file	1		—
Comments	Device comment file	1	2 Mbytes	—

3.2 Files

The CPU module files are explained below.

File type and storage destination memory

File types and their storage destination memory are explained below.

○: Can be stored, ×: Cannot be stored

File type	CPU built-in memory	SD memory card	File name (extension)
	Data memory		
	Drive No.4	Drive No.2	
Program	○	○	Arbitrary.PRG
FB files	○	○	Arbitrary.PFB
CPU parameters	○	○	CPU.PRM
System parameters	○	○	SYSTEM.PRM
Module parameters	○	○	UNIT.PRM
Memory card parameter	×	○	MEMCARD.PRM
Device comments	○	○	Arbitrary.DCM
Device initial values	○	○	Arbitrary.DID
Global label settings	○	○	GLBLINF.IMG
Module extension parameter (for protocol setting)	○	○	UEX3FF01.PPR ^{*1} UEX3FF00.PPR ^{*2}
Restored information	○	○	CallTreeInfo.CAB SourceInfo.CAB

*1 For serial communications file.

*2 For Ethernet file.

Executable file operations

File operations that can be executed on each file are explained below. This operation is possible only when the operation status of the CPU module is the STOP status.

○: Can be executed, —: No corresponding operation

File type	Operation with engineering tool		
	Write	Read	Delete
Program	○	○	○
FB files	○	○	○
Parameters	○	○	○
Device comments	○	○	○
Device initial values	○	○	○
Global label setting file	—	—	—
Restored information	○	○	○

PART 2 FUNCTIONS

This part consists of the following chapters.

4 FUNCTION LIST

5 SCAN MONITORING FUNCTION

6 CLOCK FUNCTION

7 ONLINE CHANGE

8 INTERRUPT FUNCTION

9 PID CONTROL FUNCTION

10 CONSTANT SCAN

11 REMOTE OPERATION

12 DEVICE/LABEL MEMORY AREA SETTING

13 INITIAL DEVICE VALUE SETTING

14 LATCH FUNCTION

15 MEMORY CARD FUNCTION

16 DEVICE/LABEL ACCESS SERVICE PROCESSING SETTING

17 RAS FUNCTIONS

18 SECURITY FUNCTIONS

19 BUILT-IN I/O FUNCTION

20 BUILT-IN ANALOG FUNCTION

4 FUNCTION LIST

The following table lists the functions of the CPU module.

Function		Description	Reference
Scan monitoring function (Watchdog timer setting)		Detects an error in the hardware and program of the CPU module by monitoring the scan time.	Page 44
Clock function		This function is used for the time management in the function which the system operates such as the date of the error history.	Page 46
Online change	Changing ladder blocks while online	Writes the part of a program edited on the ladder editor using the engineering tool to the CPU module in units of ladder blocks. Edited contents spanning multiple portions can be written to the CPU module at once.	Page 50
Interrupt function	Multiple interrupt function	When an interrupt occurs while an interrupt program triggered by another cause is running, stops the program if its priority is lower than that of the new interrupt, and runs the higher-priority program whenever its execution condition is satisfied.	Page 53
PID control function		Performs PID control by the PID control instruction.	Page 55
Constant scan		Keeps the scan time constant and executes program repeatedly.	Page 84
Remote operation	Remote RUN/STOP	Changes the CPU module status to the RUN/STOP/PAUSE status externally while the RUN/STOP/RESET switch of the CPU module is in RUN status.	Page 86
	Remote PAUSE		
	Remote RESET	Resets the CPU module externally while the CPU module is in the STOP status.	
Device/label memory area setting		Sets the capacity of each area in the device/label memory.	Page 92
Initial device value setting		Sets the initial values of devices used in the program directly (not via the program) to the devices.	Page 97
Latch function		Holds the contents of the device and label of the CPU module when the power is turned ON etc.	Page 99
Memory card function	SD memory card forced stop	Makes the SD memory card unavailable without turning OFF the power even when the function accessing the SD memory card is executed.	Page 103
	Boot operation	Transfers the file stored in the SD memory card to the transfer destination memory judged automatically by the CPU module when the power is turned ON or is reset.	
Device/label access service processing setting		Sets the number of execution times of the device/label access service processing executed by END processing, with parameter.	Page 107
RAS function	Self-diagnostics function	Self-diagnoses the CPU module to see whether an error exist or not.	Page 109
	Error clear	Batch-clears all the continuation errors being detected.	
Security function		Protects resources stored in PCs and resources in the units in the system of the FX5 from illegal access by a third party such as theft, alteration, accidental operation and unauthorized execution.	Page 113 GX Works3 Operating Manual
Built-in input/output function	High-speed counter function	Performs high-speed counter, pulse width measurement, input interruption, timer interruption, high-speed counter interruption, etc. by using the input of the CPU module.	Page 114
	Pulse width measurement function		
	Input interrupt function		
	Timer interrupt function		
	High-speed counter interrupt function		
	Built-in positioning function	Executes positioning operation of up to 4 axes by using the transistor output of the CPU module.	MELSEC iQ-F FX5 User's Manual (Positioning Control)
	PWM output function	Executes a PWM output by using the transistor output of the CPU module.	Page 193
Built-in analog function	Analog input function	Two analog inputs and one analog output are built in the FX5U CPU module so that voltage input/voltage output can be performed.	Page 201 MELSEC iQ-F FX5 User's Manual (Analog Control)
	Analog output function		
Built-in Ethernet function		A function related to the Ethernet such as the connection with the MELSOFT products and GOTs, and socket communication.	MELSEC iQ-F FX5 User's Manual (Ethernet Communication)
Serial communication function		A function related to the serial communication such as N:N Network, MC protocol, inverter communication function and non-protocol communication.	MELSEC iQ-F FX5 User's Manual (Serial Communication)

Function	Description	Reference
MODBUS RTU communication function	Connection with the products which support MODBUS RTU is available. The master and slave functions can be used.	MELSEC iQ-F FX5 User's Manual (MODBUS Communication)

5 SCAN MONITORING FUNCTION

This function detects CPU module hardware or program errors by monitoring the scan time. Using the watchdog timer, which is an internal timer in the CPU module, the following scans are monitored.

- Initial scan (1st scan)
- 2nd scan and after

5.1 Scan time monitoring time setting

Sets the scan time monitoring time.

Navigation window ⇒ [Parameter] ⇒ [FX5UCPU] ⇒ [CPU Parameter] ⇒ "RAS Setting" ⇒ "Scan Time Monitoring Time (WDT) Setting"

Window

Item	Setting
Scan Time Monitoring Time (WDT) Setting	
Initial Scan	2000 ms
After 2nd Scan	200 ms

Displayed items

Item	Description	Setting range	Default
Initial Scan	Sets the scan-time monitoring time (WDT) for the initial scan (first scan).	10 to 2000 ms (10 ms units)	2000 ms
After 2nd Scan	Sets the scan-time monitoring time (WDT) for the second and later scans.	10 to 2000 ms (10 ms units)	200 ms

5.2 Resetting of the watchdog timer

Resets the watchdog timer when the END/FEND instruction is executed. When the CPU module operates normally and executes the END/FEND instruction within the watchdog timer setting, the time of the watchdog timer will not time up. If the END/FEND instruction cannot be executed within the watchdog timer setting due to increased program execution as a result of hardware error or interrupt in the CPU module, the time of the watchdog timer will time up.

5.3 Precautions

The following precautions relate to the scan monitoring function.

Watchdog timer reset when executing a program repeatedly

The watchdog timer can be reset by executing the WDT instruction in a program. If the time of the watchdog timer is up while executing a program repeatedly by the FOR instruction and NEXT instruction, use the WDT instruction to reset the watchdog timer.

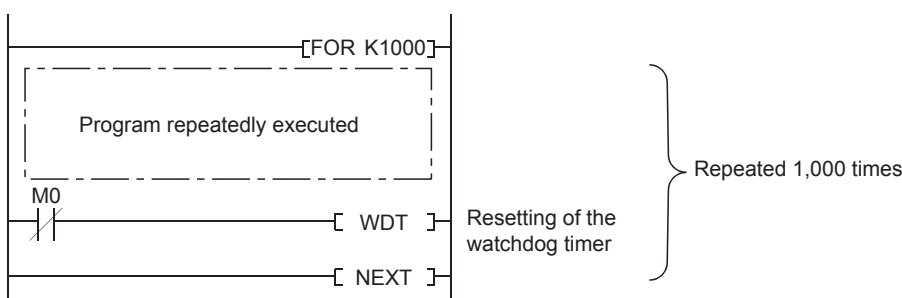

Scan time when the WDT instruction is used

Even though the watchdog timer is reset using the WDT instruction, the scan time value is not reset. The scan timer value is the value measured up to the END instruction.

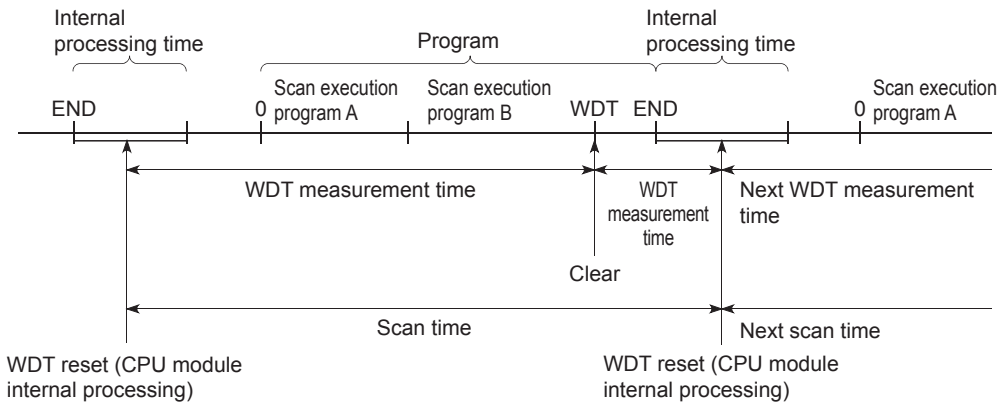

6 CLOCK FUNCTION

The CPU module has an internal clock and is used to manage time in functions performed by the system such as dates of the error history.

6.1 Time Setting

Time operation continues with the large internal capacitor in the CPU module even though the power in the CPU module is turned OFF or the power failure exceeds the allowable momentary power failure time.

If an optional battery is used, operation continues by the battery.

Clock data

The clock data handled in the CPU unit is described below.

Data name	Description
Year	4 digits in calendar year (1980 to 2079)
Month	1 to 12
Day	1 to 31 (Leap year auto detect)
Hour	0 to 23 (24-hour system)
Minute	0 to 59
Second	0 to 59
Day-of-the-week	0: Sunday, 1: Monday, 2: Tuesday, 3: Wednesday, 4: Thursday, 5: Friday, 6: Saturday

Changing the clock data

The clock data can be changed using the following methods.

- Using engineering tools
- Using SM/SD
- Using instructions

Using the engineering tool

Clock data can be changed using Set Clock from the menu. ([GX Works3 Operating Manual](#))

Using SM/SD

The values stored in SD210 (clock data) to SD216 (clock data) are written to the CPU module after END processing execution of scan when SM210 (clock data set request) is changed from OFF→ON. If the data from SD210 to SD216 is out of the valid range, SM211 (clock data set error) is turned ON, the values from SD210 to SD216 are not written in the CPU module.

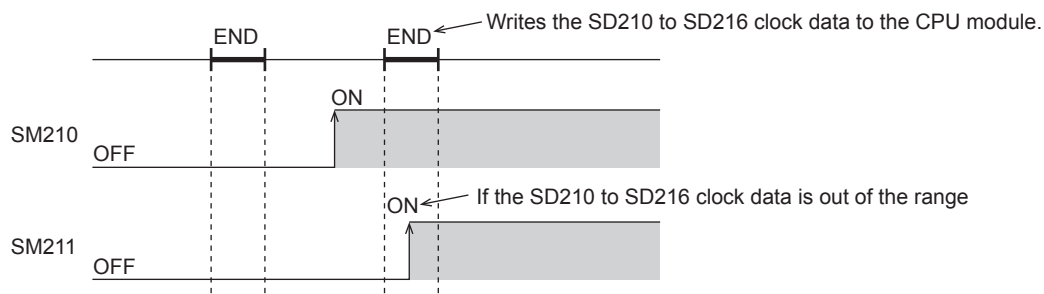

Using instructions

Writes the clock data to the CPU module, using the TWR(P) instruction. ([MELSEC iQ-F FX5 Programming Manual](#) (Instructions, Standard Functions/Function Blocks))

Reading clock data

There are the following methods to read clock data.

- Using SM/SD
- Using instructions

Using SM/SD

Clock data is read to SD210 to SD216 when SM213 (clock data read request) is turned ON.

Using instructions

Clock data is read from the CPU module using the TRD(P) instruction. ( MELSEC iQ-F FX5 Programming Manual (Instructions, Standard Functions/Function Blocks))

Precautions

The following describes precautions when setting the time.

When setting the clock for the first time

The clock is not set when the product is shipped.

Correcting the clock data

Before correcting any part of the clock data, you must write all data into the CPU module again.

6.2 Setting Time Zone

The time zone used for the CPU module can be specified. Specifying the time zone enables the clock of the CPU module to work in the local time zone.

Navigation window ⇒ [Parameter] ⇒ [FX5UCPU] ⇒ [CPU Parameter] ⇒ "Operation Related Setting" ⇒ "Clock Related Setting"

Window



Displayed items

Item	Description	Setting range	Default
Time Zone	Sets the time zone used by the CPU module.	<ul style="list-style-type: none"> • UTC+13 • UTC+12 • UTC+11 • UTC+10 • UTC+9:30 • UTC+9 • UTC+8 • UTC+7 • UTC+6:30 • UTC+6 • UTC+5:45 • UTC+5:30 • UTC+5 • UTC+4:30 • UTC+4 • UTC+3:30 • UTC+3 • UTC+2 • UTC+1 • UTC • UTC-1 • UTC-2 • UTC-3 • UTC-3:30 • UTC-4 • UTC-4:30 • UTC-5 • UTC-6 • UTC-7 • UTC-8 • UTC-9 • UTC-10 • UTC-11 • UTC-12 	UTC+9
Comment	Enters a comment for the time zone (e.g., name of the city).	1 to 32 letters	—

Point

To reflect the time zone setting on the CPU module, the module must be restarted. If no parameter is set for the CPU module (factory setting), it operates with "UTC+9".

6.3 System clock

There are two types of system clocks, one is to execute ON/OFF by the system and the other is to execute ON/OFF in the intervals specified by the user.

Special relay used for system clock

Special relays used for system clock are as follows.

Special relay	Name
SM400, SM8000	Always ON
SM401, SM8001	Always OFF
SM402, SM8002	After RUN, ON for one scan only
SM403, SM8003	After RUN, OFF for one scan only
SM409, SM8011	0.01 second clock
SM410, SM8012	0.1 second clock
SM411	0.2 second clock
SM412, SM8013	1 second clock
SM413	2 second clock
SM414	2n second clock
SM415	2n ms clock
SM8014	1 min clock
SM420, SM8330	Timing clock output 1
SM421, SM8331	Timing clock output 2
SM422, SM8332	Timing clock output 3
SM423, SM8333	Timing clock output 4
SM424, SM8334	Timing clock output 5

Special register used for system clock

Special registers used for system clock are as follows.

Special register	Name
SD412	One second counter
SD414	2n second clock setting
SD415	2n ms clock setting
SD420	Scan counter
SD8330	Counted number of scans for timing clock output 1
SD8331	Counted number of scans for timing clock output 2
SD8332	Counted number of scans for timing clock output 3
SD8333	Counted number of scans for timing clock output 4
SD8334	Counted number of scans for timing clock output 5

Point

SM420 to SM424, SM8330 to SM8334, and SD8330 to SD8334 are used by the DUTY instruction. For the DUTY instruction, refer to the following.

 MELSEC iQ-F FX5 Programming Manual (Instructions, Standard Functions/Function Blocks)

7 ONLINE CHANGE

This chapter describes online change.

7.1 Online Ladder Block Change

Writes the portion edited on the ladder edit window of the engineering tool to the CPU module in increments of ladders. Edited contents spanning multiple files or multiple portions can be written to the CPU module at once.

Point

For details on the operating procedure of online ladder block change on engineering tools, refer to the following.

 GX Works3 Operating Manual

Editable contents

Within a program block, instructions and pointers (P, I) can be added, changed, or deleted. Also, as POU unit, program blocks can be added, changed, or deleted. However, when the program/FB file is not in agreement between engineering tool and a CPU module, it cannot be added, changed, or deleted.

Range changeable in a single session

The following shows the number of steps and number of ladder blocks which can be changed in a single session.

- Number of ladder blocks in a file: 64 blocks or less (2048 steps or less)
- The total of the changed circuit block count in all files: 256 blocks or less
- The total capacity of the program file and the FB file after a change: 1 M byte or less

Online ladder block change during the boot operation

If online change of ladder block is executed from the SD memory card during boot operation, the corresponding file in the SD memory card, which is the boot source, can be changed as well.

Precautions

This section describes the precautions on using online ladder block change.

Prohibited operation at online ladder block change

When an online change of ladder block, if the power is turned OFF or a reset is made, the process does not end normally. Such operation is made, execute rewriting to the PLC.

When deleting OUT instruction which is on

When deleting an OUT instruction (coil) which is not necessary for control, be sure to check that the OUT instruction is off before deleting it. If the OUT instruction is deleted without turning it off in advance, the output will be retained.

Program file not registered in program setting

A program file which is not registered in parameter setting cannot be written.

Initializing the last execution if the ladder at online ladder block change has an FB call

- If a subroutine type FB is called in a FB definition, the execution information of the previous time in the FB definition of the subroutine type FB is not initialized.
- If a macro type FB is called in the FB definition of a subroutine type, the execution information of the previous time in the part equivalent to the macro type FB is not initialized either.

Instructions not compatible with online ladder block change

Do not execute online change to ladder block including the following instruction.

DSZR instruction, DVIT instruction, TBL instruction, DRVTBL instruction, PLSV instruction, DRVI instruction, DRVA instruction, DRVMUL instruction, PLSY instruction, PWM instruction, SPD instruction, HIOEN instruction, UDCNTF LCO instruction, ABS instruction, ADPRW instruction, IVCK instruction, IVDR instruction, IVRD instruction, IVWR instruction, IVBWR instruction, IVMC instruction, S.CPRTCL instruction, SP.CPRTCL instruction, RS2 instruction, SP.SOCOPEN instruction, SP.SOCCLOSE instruction, SP.SOCSND instruction, SP.SOCRCV instruction, SP.ECPRTCL instruction, RBFM instruction, WBFM instruction

The cautions at the time of repeatedly performing online change

When online change is performed repeatedly, RUN writing may not be able to be carried out due to insufficient memory in the CPU module. Please set the CPU module to STOP and write the program.

The operation when a pulse type instruction is included in the range of an online ladder block change

The operation when a pulse related instruction is included in the range of an online ladder block change is as follows.

Pulse type instruction	Description
Rising instruction (PLS and □P instructions)	When a rising instruction exists within the range to be changed, the rising instruction will not be executed if the execution condition (OFF to ON) is fulfilled at completion of online program change.
Falling instruction (PLF and □F instructions)	When a falling instruction exists within the range to be changed, the falling instruction will not be executed even if the execution condition (ON to OFF) is fulfilled at completion of online program change.

■Rising instruction

When a rising instruction exists within the range to be changed, the rising instruction will not be executed if the execution condition (OFF to ON) is fulfilled at completion of online program change.

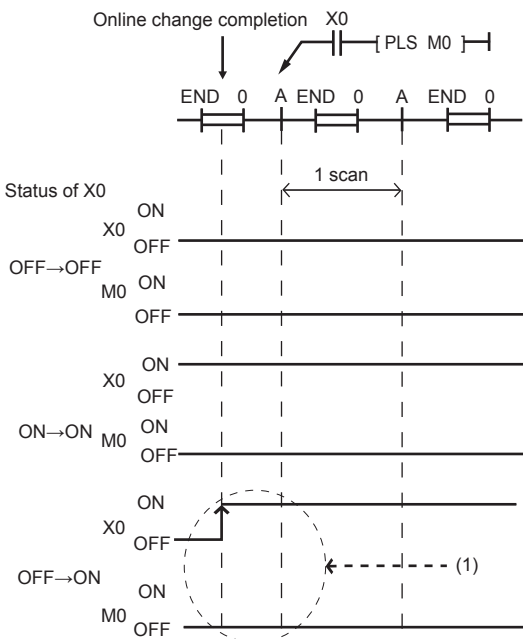

(1) The rising instruction will not be executed even if the execution condition is OFF to ON.

■Falling instruction

When a falling instruction exists within the range to be changed, the falling instruction will not be executed even if the execution condition (ON to OFF) is fulfilled at completion of online program change.

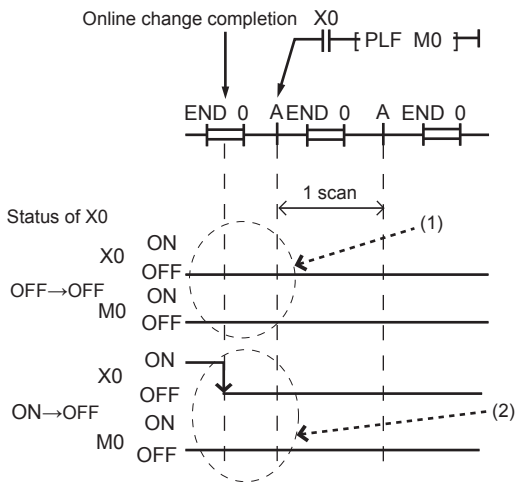

(1) The falling instruction will not be executed even if the execution condition is OFF to OFF.

(2) If online program change and transition of ON to OFF occur simultaneously, the falling instruction will not be executed.

8 INTERRUPT FUNCTION

This chapter describes the interrupt function.

8.1 Multiple Interrupt Function

When an interrupt occurs while an interrupt program triggered by another cause is running, stops the program if its priority is lower than that of the new interrupt, and runs the higher-priority program whenever its execution condition is satisfied.



• When the multiple interrupt function is enabled

[Priority]

- I10: High
- I0: Low

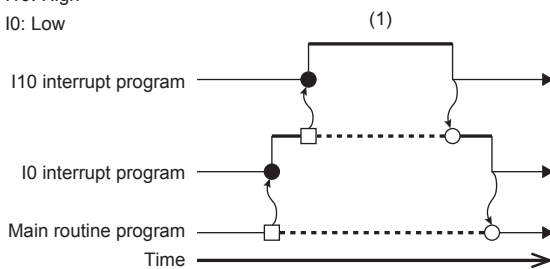

• When not set (at default)

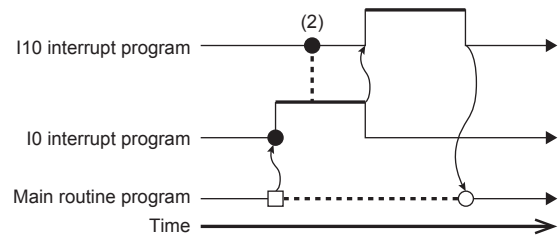

(1) A high-priority interrupt is executed by interrupting a low-priority interrupt.

(2) Even if a high-priority interrupt occurs, it enters the waiting status until the executing interrupt is completed.

Interrupt priority

If the interrupt priority of a program for which its execution condition has been satisfied is higher than that of the running program, the programs are executed in accordance with their interrupt priority. If the interrupt priority of the new program is the same or lower, it enters the waiting status until the running program finishes.

Interrupt priority setting

The interrupt priority (1 to 3) of interruptions from modules can be changed.

Navigation window ⇒ [Parameter] ⇒ [FX5UCPU] ⇒ [CPU Parameter] ⇒ "Interrupt Settings" ⇒ "Interrupt Priority Setting from Module"

Operating procedure

"Interrupt Settings" window

Item	Setting
Interrupt Priority Setting from Module	
Multiple Interrupt	Enable
Interrupt Priority	<Detailed Setting>

"Detailed Setting" window

Interrupt Pointer	Priority
I0	2
I1	2
I2	2
I3	2
I4	2
I5	2
I6	2
I7	2
I8	2
I9	2
I10	2
I11	2
I12	2
I13	2
I14	2
I15	2

1. Set Multiple Interrupt to "Enable" on the "Interrupt Settings" window, and click "Detailed Setting".
2. Change the priority of each interrupt pointer.

Displayed items

Item	Description	Setting range	Default
Multiple Interrupt	Sets whether or not to enable multiple interrupt.	<ul style="list-style-type: none"> • Disable • Enable 	Disable
Interrupt Priority	Detailed Setting	Sets the priority of the interrupt pointers I0 to I31.	1 to 3 ^{*1}
			2

*1 The lower the numerical value, the higher the interrupt priority.

Disabling/enabling interrupts with a specified or lower priority

Interrupts with a priority equal or lower than that specified by the DI or EI instruction can be disabled or enabled even when multiple interrupts are present.

For details, refer to MELSEC iQ-F FX5 Programming Manual (Instructions, Standard Functions/Function Blocks).

Point

Disabled interrupt priorities and the current interrupt priority can be checked in SD758 (Interrupt disabling for each priority setting value) and SD757 (Current interrupt priority) respectively.

9 PID CONTROL FUNCTION

9.1 Outline of Function

PID control is performed by PID control instruction. The PID instruction requires the system to calculate the output (MV) value from the measured (PV) value. Through combining the P (proportional) action, I (integral) action, and D (derivative) action the target (SV) value can be obtained.

- Alarm output function

The alarm function can be set for input variation (measured value) or output variation (value).

- Setting limit values

The upper limit and lower limit can be set for the output value.

- Auto-tuning function

The proportional gain (KP), integral time (TI) and differential time (TD) can be set automatically for both the limit cycle method and step response method.

- Operation method of the PID instruction

Both PID speed type operation and measured value differential type operation are executed.

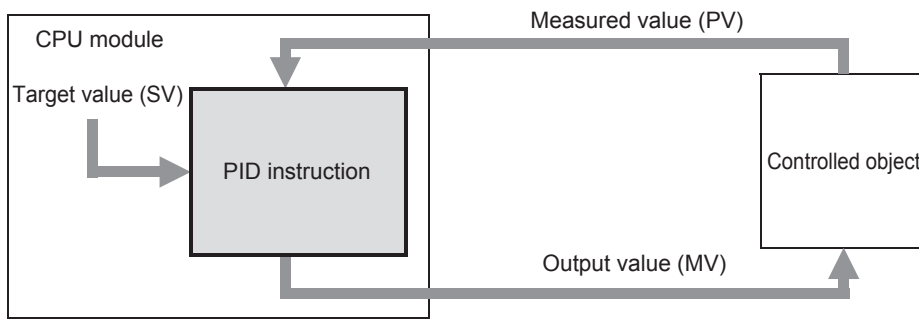

9.2 Basic Operation Expressions in PID Instruction

The PID instruction executes using the speed type or measured value differential type operation expression. According to the contents of (s3)+1, bit 0 (operation setting (ACT)) specified by (s3) in the PID control, either forward operation or backward operation is executed. Each value required in the operation is specified by a corresponding parameter (s3) or later.

Basic operation expression for PID control

Operation setting (ACT) (s3+1: b0)	Operation expression	The meaning of the signs
Forward operation (OFF)	$\Delta MV = KP \left\{ (EV_n - EV_{n-1}) + \frac{TS}{TI} EV_n + D_n \right\}$ $EV_n = PV_{nf} - SV$ $D_n = \frac{TD}{TS + KD \cdot TD} (-2PV_{nf-1} + PV_{nf} + PV_{nf-2}) + \frac{KD \cdot TD}{TS + KD \cdot TD} \cdot D_{n-1}$ $MV_n = \sum \Delta MV$	EV _n : Deviation in sampling at this time EV _{n-1} : Deviation in previous cycle SV: Target value PV _{nf} : Measured value in sampling at this time (after filter) PV _{nf-1} : Measured value in previous cycle (after filter) PV _{nf-2} : Measured value in two cycles before (after filter)
Backward operation (ON)	$\Delta MV = KP \left\{ (EV_n - EV_{n-1}) + \frac{TS}{TI} EV_n + D_n \right\}$ $EV_n = SV - PV_{nf}$ $D_n = \frac{TD}{TS + KD \cdot TD} (2PV_{nf-1} - PV_{nf} - PV_{nf-2}) + \frac{KD \cdot TD}{TS + KD \cdot TD} \cdot D_{n-1}$ $MV_n = \sum \Delta MV$	ΔMV: Output variation MV _n : Operation quantity at this time D _n : Differential term at this time D _{n-1} : Differential term in previous cycle TS: Sampling cycle KP: Proportional gain TI: Integral constant TD: Differential constant KD: Differential gain

Expression for calculating the measured value (after the filter) in sampling at this time (PVnf)

The value "PVnf" is obtained from the following expression based on the read measured value.

Measured value after filter: $PVnf = PVn + L (PVnf - 1 - PVn)$

PVn: Measured value in sampling at this time

L: Filter coefficient

PVnf-1: Measured value in previous cycle (after filter)

9.3 How to Use PID Instruction

This instruction executes PID control which changes the output value according to the input variation.

For details on the PID instruction, refer to the following manual.

📖 MELSEC iQ-F FX5 Programming Manual (Instructions, Standard Functions/Function Blocks)

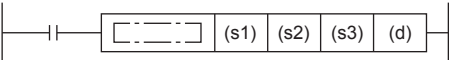
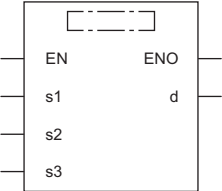
Ladder diagram	Structured text
	<pre>ENO:=PID(EN,s1,s2,s3,d);</pre>
FBD/LD	
	

Setting data

■ Descriptions, ranges, and data types

Operand	Description	Range	Data type	Data type (label)
(s1)	Device number storing the target value (SV)	-32768 to +32767	16-bit signed binary	ANY16
(s2)	Device number storing the measured value (PV)	-32768 to +32767	16-bit signed binary	ANY16
(s3)	Device number storing PID parameters	1 to 32767	16-bit signed binary	ANY16
(d)	Device number storing the output value (MV)	-32768 to +32767	16-bit signed binary	ANY16

■ Applicable devices

Operand	Bit			Word			Double word		Indirect specification	Constant			Others
	X, Y, M, L, SM, F, B, SB, S	U□\G□	T, ST, C, LC	T, ST, C, D, W, SD, SW, R	U□\G□	Z	LC	LZ		K, H	E	\$	
(s1)	—	—	—	○*1	○	—	—	—	—	—	—	—	—
(s2)	—	—	—	○*1	○	—	—	—	—	—	—	—	—
(s3)	—	—	—	○*1	—	—	—	—	—	—	—	—	—
(d)	—	—	—	○*1	○	—	—	—	—	—	—	—	—

*1 Only D, SD, R can be used.

Processing details

- Once the target value (s1), measured value (s2) and PID parameters (s3) to (s3)+6 are set and the program is executed, the operation result (MV) is transferred to the output value (d) at every sampling time. The sampling time is specified by (s3)

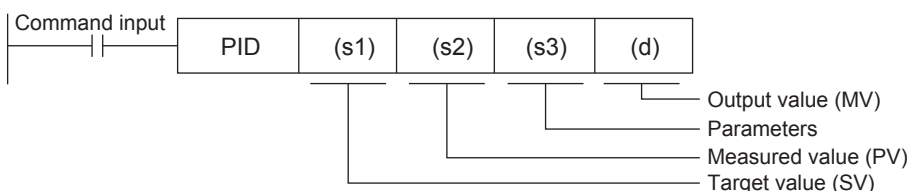

■Set item

Set item		Description	Occupied points
(s1)	Target value (SV)	The target value (SV) is set. The PID instruction does not change the settings. [Caution on using the auto-tuning (limit cycle method)] If the target value for auto-tuning is different from the target value in the PID control, it is necessary to set a value to which a bias value is added, and then store the actual target value when the auto-tuning flag turns OFF.	1 point
(s2)	Measured value (PV)	This is the input value of the PID operation. It is necessary to read a normal measurement data before the execution of the PID operation for the measurement value of PID (PV). If an input value from an analog input is used for the PID operation, use caution to its conversion time.	1 point
(s3)	Parameter	PID control 25 devices are occupied from the head device specified in (s3)	25 points
		Auto-tuning: In the limit cycle (1) 29 devices are occupied from the head device specified in (s3)	29 points
		Auto-tuning: In the step response method (2) 25 devices are occupied from the head device specified in (s3)	25 points
(d)	Output value (MV)	PID control (normal processing) The user sets the initial output value before driving the instruction. After that, the operation result is stored.	1 point
		Auto-tuning: In the limit cycle The Upper Limit Value (ULV) or Lower Limit Value (LLV) value is automatically output during auto-tuning. The specified MV value is output when auto-tuning is finished.	
		Auto-tuning: In the step response method The user sets the step output value before driving the instruction. The MV value is not changed by PID instruction during auto-tuning.	

■Precautions for using the PID instruction

For the precautions for using the PID instruction, refer to the following manual.

📖 MELSEC iQ-F FX5 Programming Manual (Instructions, Standard Functions/Function Blocks)

9.4 Relationship Between Parameter Setting and Auto-Tuning

When auto-tuning is not executed (parameter setting)

It is necessary to write the set value of the parameters (s3) to (s3)+6 using MOV instruction in advance, etc. before starting the PID operation when auto-tuning is not executed. If a device with a latch setting is specified, the setting data is retained even after the power to the CPU module is turned OFF; therefore, the writing at the 2nd power ON is not required.

For details on parameters, refer to 📖 Page 58 Parameter.

When auto-tuning is executed

The proportional gain ((s3)+3), integral time ((s3)+4) and differential time ((s3)+6) are important constants for executing the auto-tuning function described later and for optimizing the PID control. These constants can be set automatically.

For a detailed description of auto-tuning, refer to 📖 Page 68 Auto-Tuning.

9.5 Parameter

Set item	Description/Setting range		Remarks	
(s3)	Sampling time (TS)		1 to 32767 (ms)	It cannot be shorter than operation cycle of the PLC.
(s3)+1	Operation setting (ACT)	b0	0: Forward operation 1: Backward operation	Operation direction
		b1	0: Input variation alarm is invalid 1: Input variation alarm is valid	—
		b2	0: Output variation alarm is invalid 1: Output variation alarm is valid	Do not set b2 and b5 to ON at the same time.
		b3	Not used	—
		b4	0: Auto-tuning is not executed. 1: Auto-tuning is executed	—
		b5	0: Upper and lower limits of output value are not valid 1: Upper and lower limits of output value are valid	Do not set b2 and b5 to ON at the same time.
		b6	0: Step response method 1: Limit cycle method	Select auto-tuning mode.
		b7 to b15	Not used	—
(s3)+2	Input filter constant (α)		0 to 99 [%]	When "0" is set, input filter is not provided.
(s3)+3	Proportional gain (KP)		1 to 32767 [%]	—
(s3)+4	Integral time (TI)		0 to 32767 [$\times 100$ ms]	When "0" is set, it is handled as " ∞ " (no integration).
(s3)+5	Differential gain (KD)		0 to 100 [%]	When "0" is set, differential gain is not provided.
(s3)+6	Differential time (TD)		0 to 32767 [$\times 10$ ms]	When "0" is set, differential is not executed.
(s3)+7 to (s3)+19	These devices are occupied for internal processing of PID operation. Do not change data.			
(s3)+20 ^{*1}	Input variation (incremental) alarm set value		0 to 32767	It is valid when operation setting (ACT) (b1 of (s3)+1) is "1".
(s3)+21 ^{*1}	Input variation (decremental) alarm set value		0 to 32767	It is valid when operation setting (ACT) (b1 of (s3)+1) is "1".
(s3)+22 ^{*1}	Output variation (incremental) alarm set value		0 to 32767	It is valid when operation setting (ACT) (b2 of (s3)+1) is "1" and (ACT) (b5 of (s3)+1) is "0".
	Output upper limit set value		-32768 to +32767	It is valid when operation setting (ACT) (b2 of (s3)+1) is "0" and (ACT) (b5 of (s3)+1) is "1".
(s3)+23 ^{*1}	Output variation (decremental) alarm set value		0 to 32767	It is valid when operation setting (ACT) (b2 of (s3)+1) is "1" and (ACT) (b5 of (s3)+1) is "0".
	Output lower limit set value		-32768 to +32767	It is valid when operation setting (ACT) (b2 of (s3)+1) is "0" and (ACT) (b5 of (s3)+1) is "1".
(s3)+24 ^{*1}	Alarm output	b0	0: Input variation (incremental) is not exceeded. 1: Input variation (incremental) is exceeded.	It is valid when operation setting (ACT) (b1 or b2 of (s3)+1) is "1".
		b1	0: Input variation (decremental) is not exceeded. 1: Input variation (decremental) is exceeded.	
		b2	0: Output variation (incremental) is not exceeded. 1: Output variation (incremental) is exceeded.	
		b3	0: Output variation (decremental) is not exceeded. 1: Output variation (decremental) is exceeded.	
(s3)+25	PV value threshold (hysteresis) width (SHPV)		Set it according to measured value (PV) fluctuation.	The setting below is required when the limit cycle method is used (when the operation setting (ACT) b6 is set to ON).
(s3)+26	Output value upper limit (ULV)		Set maximum value (ULV) of output value (MV).	
(s3)+27	Output value lower limit (LLV)		Set minimum value (LLV) of output value (MV).	
(s3)+28	Wait setting from end of tuning cycle to start of PID control (KW)		-50 to +32717 [%]	

*1 (s3)+20 to +24 become used only if b1, b2, or b5 are set to "1" to determine the action (ACT) (s3) of +1.

9.6 Details of Parameters

This chapter describes the details of parameters.

Sampling time (s3)

Set the cycle time (ms) for the PID operation. Setting range: 1 to 32767 (ms)

- In PID control and auto-tuning (Limit cycle method)

Set the sampling time longer than the operation cycle of the PLC.

- In auto-tuning (Step response method)

Set the sampling time to 1000 ms (= 1 second) or more.

Maximum error

The maximum error of the sampling time (TS) is from "- (one operation cycle+1 ms)" to "+ (one operation cycle)."

- When the sampling time (TS) is a small value

Fluctuation of the maximum error described above may cause a problem. In such a case, execute the PID instruction in the constant scan mode, or program it in a timer interrupt routine.

- When the sampling time (TS) is shorter than one operation cycle of the PLC

A PID operation error occurs, however when PID operation is executed, the sampling time (TS) is equal to the operation cycle of the PLC. In such a case, use the PID instruction in a timer interrupt, and clear (s3)+7 just before executing the PID instruction.

Operation setting (S3)+1

Forward operation/backward operation

Set the PID control direction (forward or backward).

- During auto-tuning for the limit cycle method

It is necessary to set the PID control direction (forward or backward) for auto-tuning.

- During auto-tuning for the step response method

The PID control direction (forward or backward) is not required, as the direction is automatically set when auto-tuning is complete.

Operation setting (S3)+1: b0		Operation
Forward operation (b0=OFF)	As the measured value (PV) becomes larger than the target value (SV), the output (MV) increases. For example, cooling is a forward operation.	<p>Temperature</p> <p>Measured value (PV)</p> <p>Target value (SV)</p> <p>Time</p>
Backward operation (b0=ON)	As the measured value (PV) becomes smaller than the target value (SV), the output (MV) increases. For example, heating is a backward operation.	<p>Temperature</p> <p>Measured value (PV)</p> <p>Target value (SV)</p> <p>Time</p>

- Relationship between the forward/backward operation and the output (MV), measured value (PV) and target value (SV)
The relationship is as follows.

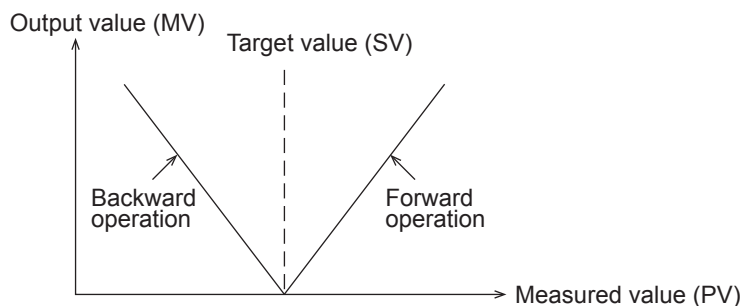

Alarm setting (for input variation and output variation)

If b1 and b2 in (s3) +1 are turned ON, the input variation and the output variation can be checked. The check is executed by following the values of (s3) +20 to (s3) +23.

These parameters can be set in (s3)+24.

For details on operation of alarm output, refer to Page 67 Alarm output (s3)+24.

- Input variation

If the input variation alarm is used, turn ON b1 in (s3) +1, and specify the input variation alarm set value.

Set item			Setting description/Setting range
Operation setting	(s3)+1: b1	Input variation alarm	ON: Used OFF: Not used
Input variation alarm set value	(s3)+20	Input variation (incremental) alarm set value	0 to 32767
	(s3)+21	Input variation (decremental) alarm set value	0 to 32767

- Output variation

If the output variation alarm is used, turn ON b1 in (s3) +1, and specify the output variation alarm set value.

When this function is used, make sure to turn OFF b5 of (s3) +1.

Set item			Setting description/Setting range
Operation setting	(s3)+1: b2	Output variation alarm	ON: Used OFF: Not used
	(s3)+1: b5	Output value upper/lower limit setting	Make sure to set it to OFF
Output variation alarm set value	(s3)+22	Output variation (incremental) alarm set value	0 to 32767
	(s3)+23	Output variation (decremental) alarm set value	0 to 32767



Variation means (Previous value) - (Current value)

Upper and lower limits for output value

When the upper and lower limit settings of the output value are valid, the output value is as shown in the chart. The upper limit and lower limit of the output value can moderate the increase of the integral item in the PID control.

When using the upper limit and lower limit of the output value, make sure to set (s3)+1, b2 to OFF.

Set item	Setting description/Setting range	
Operation setting	(s3)+1: b2	Output variation alarm Make sure to set it to OFF
	(s3)+1: b5	Output value upper/lower limit setting ON: Used OFF: Not used

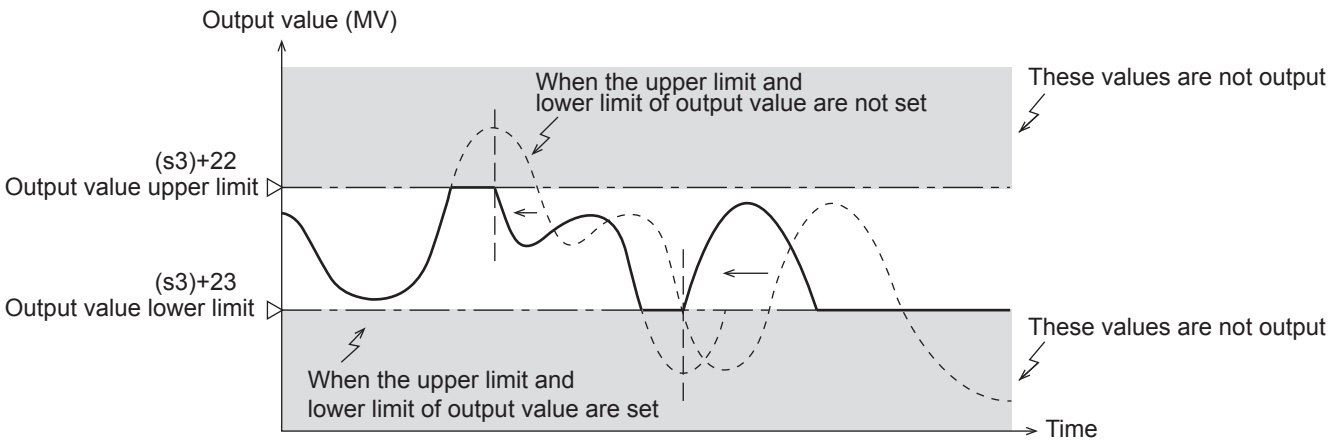

Input filter constant (s3)+2

The input filter (α) is a software filter to reduce the fluctuation of the measured value (PV) caused by noise. By setting this time constant of the filter according to the control target characteristics and noise level, the effect of noise can be reduced. If the input filter value is too small, the filter effect is small. If the input filter value is too large, the input response is bad. Setting range: 0 to 99 (%).

Because the input filter (α) acts on the target value (SV), all of the proportional operation, integral operation and differential operation are affected.

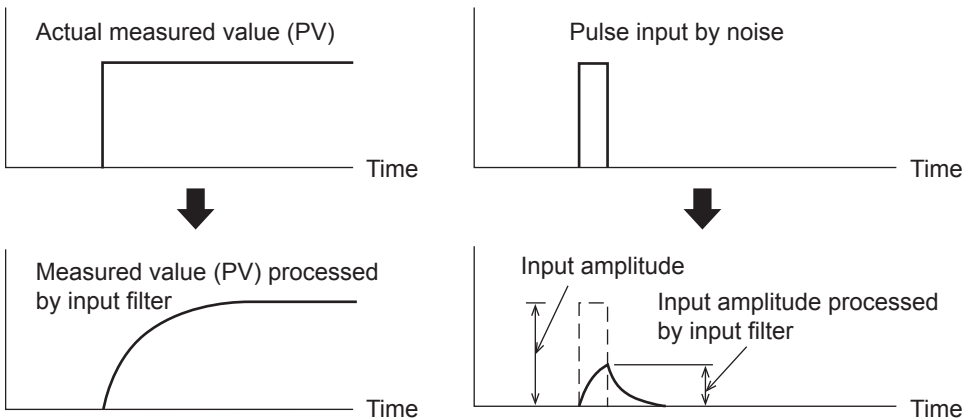

Proportional gain (s3)+3

During the proportional operation, the output (MV) increases in proportion to the deviation (difference between the target value (SV) and the measured value (PV)). This deviation is called proportional gain (Kp), and expressed in the following relational expression:

$$\text{Output (MV)} = \text{Proportional gain (KP)} \times \text{Deviation (EV)}$$

The reciprocal of the proportional gain (KP) is called proportional band. As the proportional gain (KP) is larger (as shown in the example below), the motion to let the measured value (PV) be nearer to the target value (SV) becomes stronger.

Setting range: 1 to 32767 (%)

Ex.

Proportional operation (P operation) in backward operation (heating)

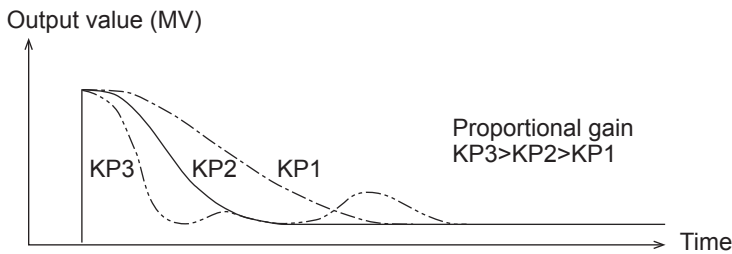
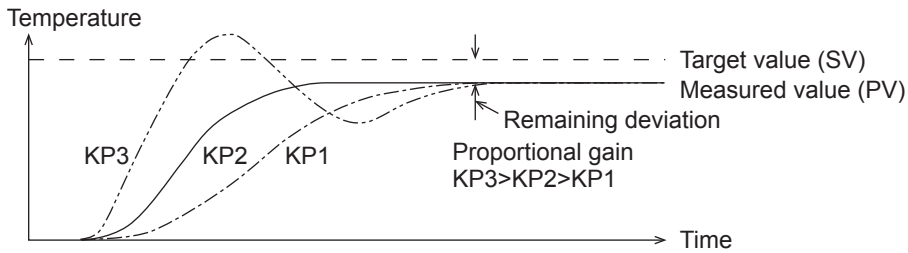

Ex.

Proportional operation (P operation) in forward operation (cooling)

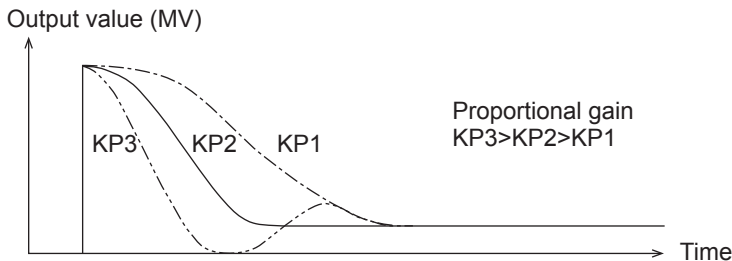
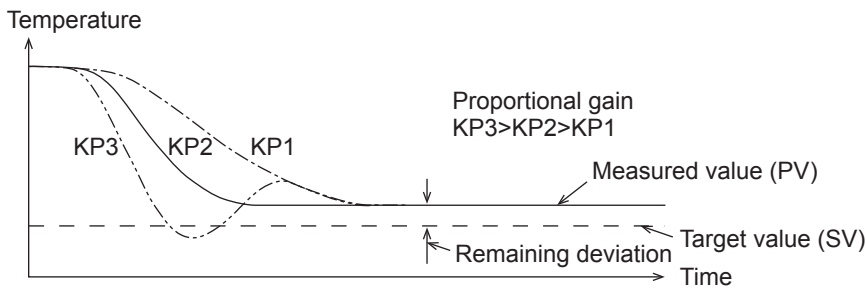

Integral time (s3)+4

During the integral operation, the time after deviation is generated until the integral operation output becomes the proportional operation output. This is called integral time and is expressed as "TI".

As TI becomes smaller, the integral operation becomes stronger.

Setting range: 0 to 32767 (× 100 ms). "0" is handled as "∞" (no integration).

Ex.

PI operation in backward operation (heating)

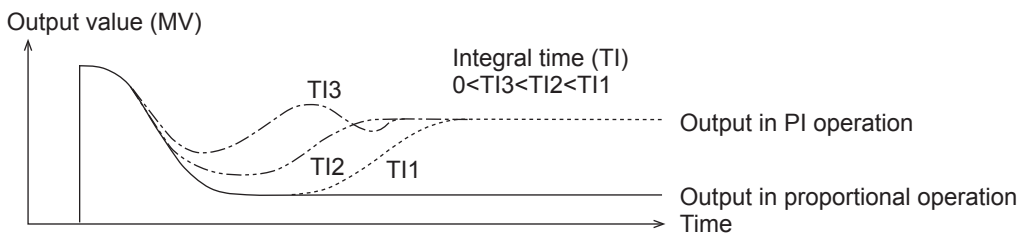
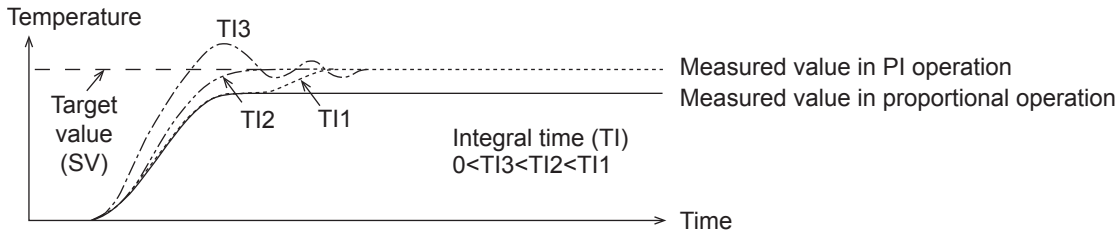

Ex.

PI operation in forward operation (cooling)

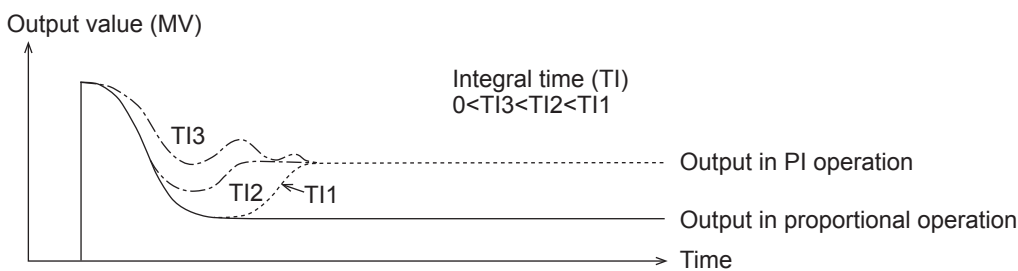
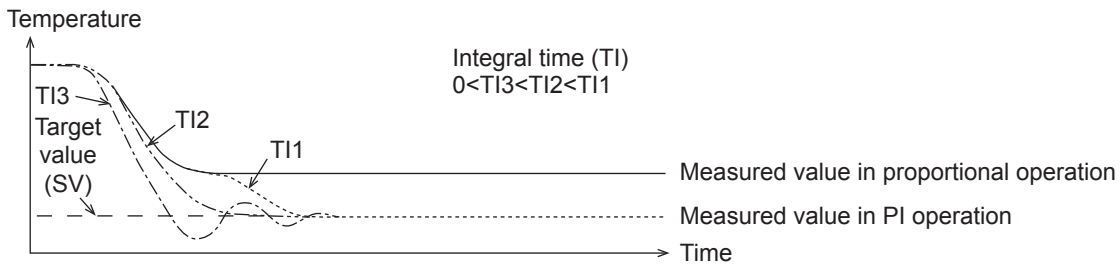

Point

The integral operation changes the output so that the continuously generated deviation is eliminated. As a result, the remaining deviation generated in the proportional operation can be eliminated.

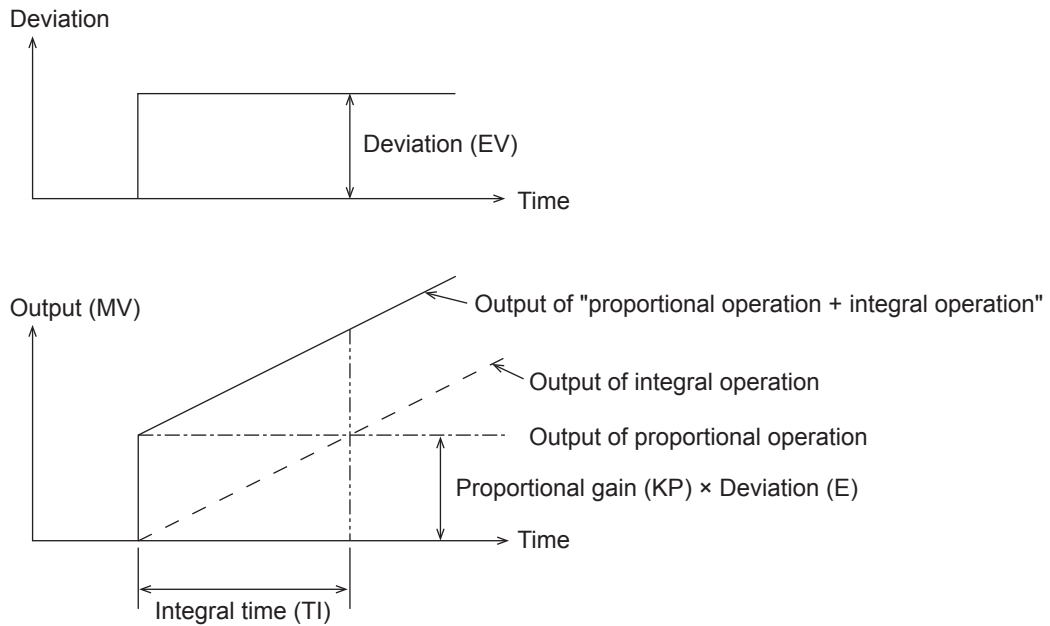

Differential gain (s3)+5

The filter is applied to the output at the differential operation. Setting range: 0 to 100 (%)

Only the differential operation is affected by the differential gain (KD).

- When the differential gain (KD) is small, the output is immediately given with regard to changes in the measured value (PV) caused by disturbance, etc.
- When the differential gain (KD) is large, the output is given after a long time with respect to changes in the measured value (PV) caused by disturbance, etc.

Point

Set the differential gain (KD) to "0", and then adjust the operation using the input filter (α).

If the output response is too close to the disturbance, increase the differential gain (KD).

Differential time (s3)+6

Use the differential time (TD) to respond sensitively to fluctuations in the measured value (PV) caused by disturbance, etc. and to minimize the fluctuations. Setting range: 0 to 32767 (× 10 ms)

- When the differential time (TD) is large, it prevent large fluctuation in the control target caused by disturbance, etc.
- It is not always necessary to use the differential time (when disturbance is small, for example).

Deviation

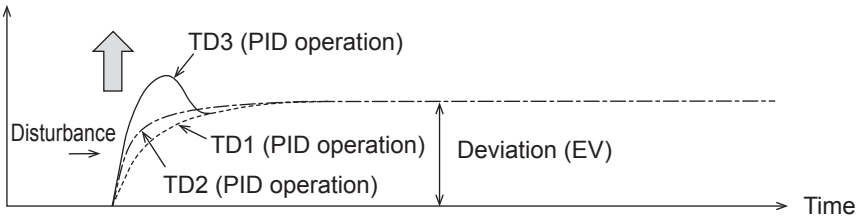

Output value (MV)

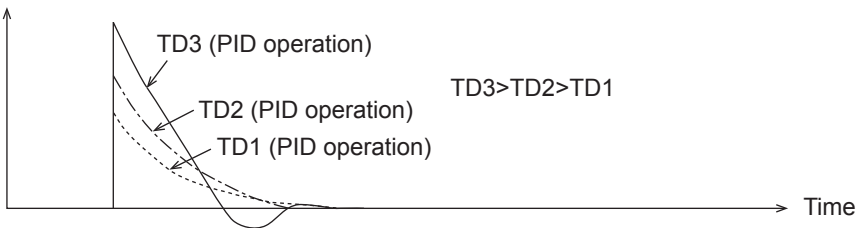

Ex.

PID operation in backward operation (heating)

Temperature

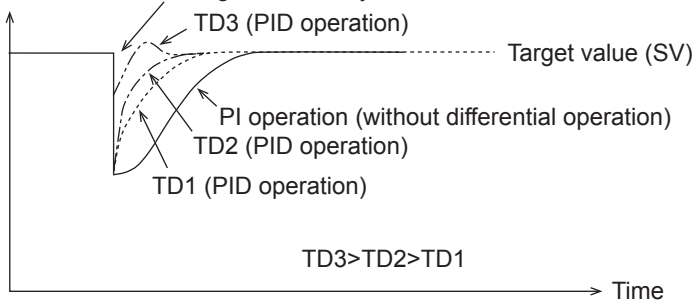

Output value (MV)

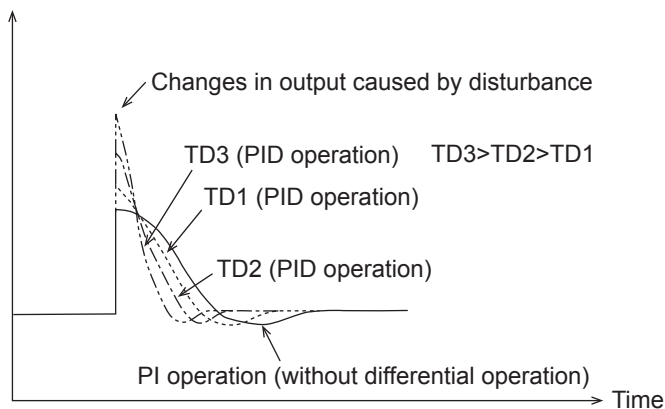

Ex.

PID operation in forward operation (cooling)

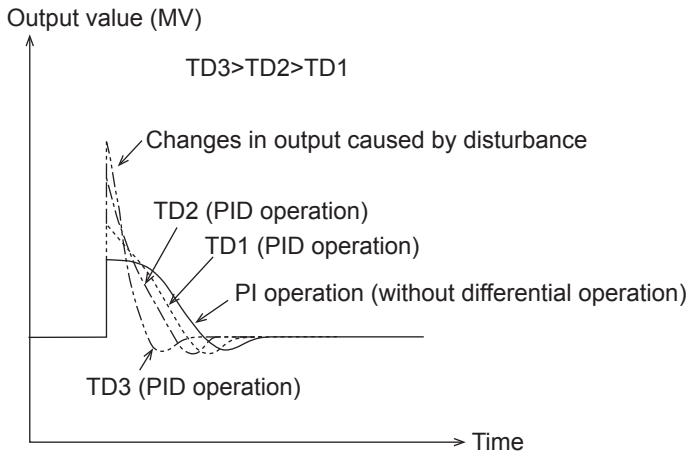
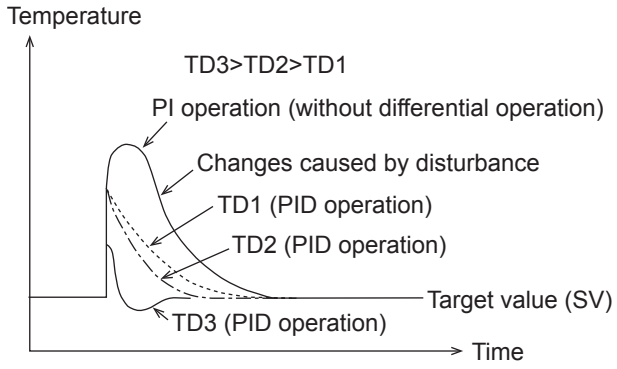

Alarm output (s3)+24

If the input variation and the output variation specified with (s3) +20 to (s3) +23 are exceeded, each bit of (s3) +24 turns ON as a warning output.

Item		Description	Remarks
Alarm output	(s3)+24: b0	OFF: Input variation (incremental) is not exceeded. ON: Input variation (incremental) is exceeded.	It is valid when operation setting (ACT) (b1 of (s3)+1) is "1".
	(s3)+24: b1	OFF: Input variation (incremental) is not exceeded. ON: Input variation (incremental) is exceeded.	
Alarm output	(s3)+24: b2	OFF: Output variation (incremental) is not exceeded. ON: Output variation (incremental) is exceeded.	It is valid when operation setting (ACT) (b2 of (s3)+1) is "1".
	(s3)+24: b3	OFF: Output variation (incremental) is not exceeded. ON: Output variation (incremental) is exceeded.	

In the case of input variation

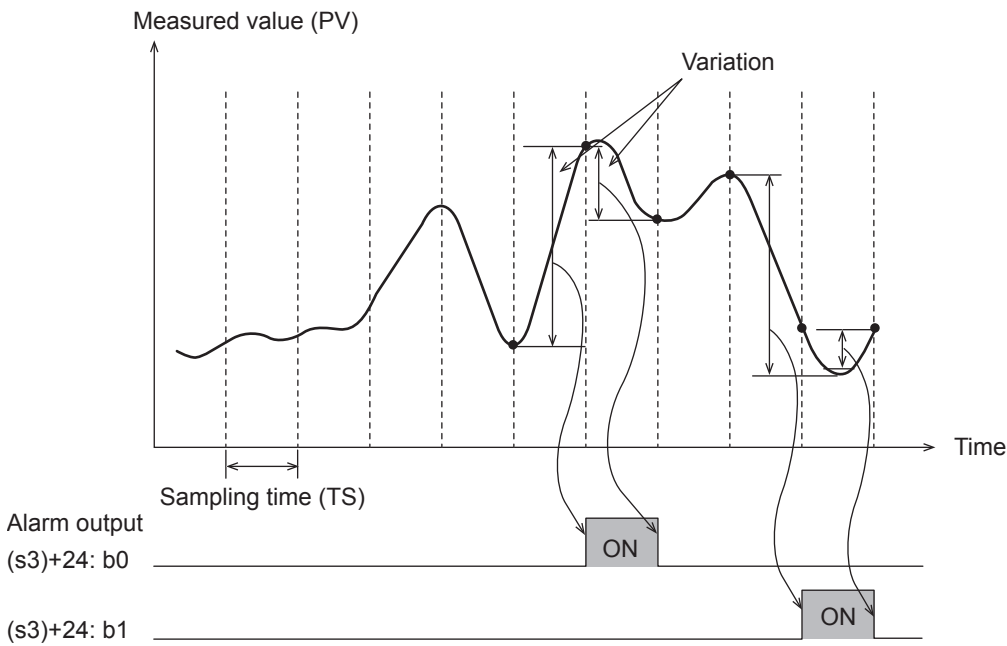

In the case of output variation

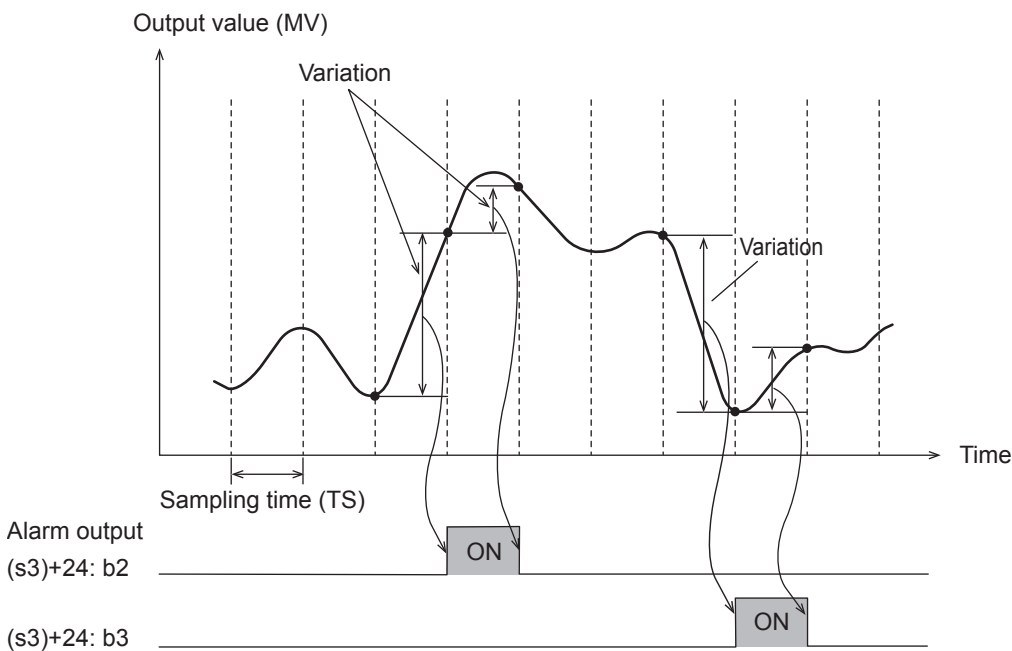

9.7 Auto-Tuning

This chapter describes the auto-tuning function of PID instruction.

The auto-tuning function will automatically set the important constants, such as the proportional gain and the integral time, to ensure optimum PID control. There are two auto-tuning methods: limit cycle method and step response method.

Limit Cycle Method

For acquiring satisfactory control results in PID control, it is necessary to obtain the optimal value of each constant (parameter) suitable to the control target. This paragraph explains the limit cycle method to obtain the amplitude (a) and vibration cycle (τ , τ_{on}) of the input value, and then calculate the proportional gain (KP), integral time (TI) and differential time (TD) based on the expressions shown in the table below.

What is the limit cycle method? Changes in the input value in two-position control (in which the output Upper Limit Value (ULV) and output Lower Limit Value (LLV) are switched according to the deviation) are measured, and then three constants in the PID control are obtained.

How to obtain three constants in PID control (Reference)

■ Operation characteristics and three constants

Control type	Proportional gain (KP) [%]	Integral time (TI) [$\times 100$ ms]	Differential time (TD) [$\times 10$ ms]
Only proportional control (P operation)	$\frac{1}{a}(ULV-LLV)\times 100$	—	—
PI control (PI operation)	$\frac{0.9}{a}(ULV-LLV)\times 100$	$33\times\tau_{on}\left(1-\frac{\tau_{on}}{\tau}\right)$	—
PID control (PID operation)	$\frac{1.2}{a}(ULV-LLV)\times 100$	$20\times\tau_{on}\left(1-\frac{\tau_{on}}{\tau}\right)$	$50\times\tau_{on}\left(1-\frac{\tau_{on}}{\tau}\right)$

■ Operation characteristics (in an example of backward operation)

During the " τW " period after the tuning cycle is finished, the output value is held at the output Lower Limit Value (LLV), and then normal PID control is started. The value " τW " can be obtained by the expression " $\tau W = (50 + KW)/100 \times (\tau - \tau_{on})$ ", and the wait setting parameter " KW " can be set in the parameter (s3)+28. (Setting range: $Kw = -50$ to $+32717$ [%]) (When the abnormal range is specified, " τW " is handled as "0")

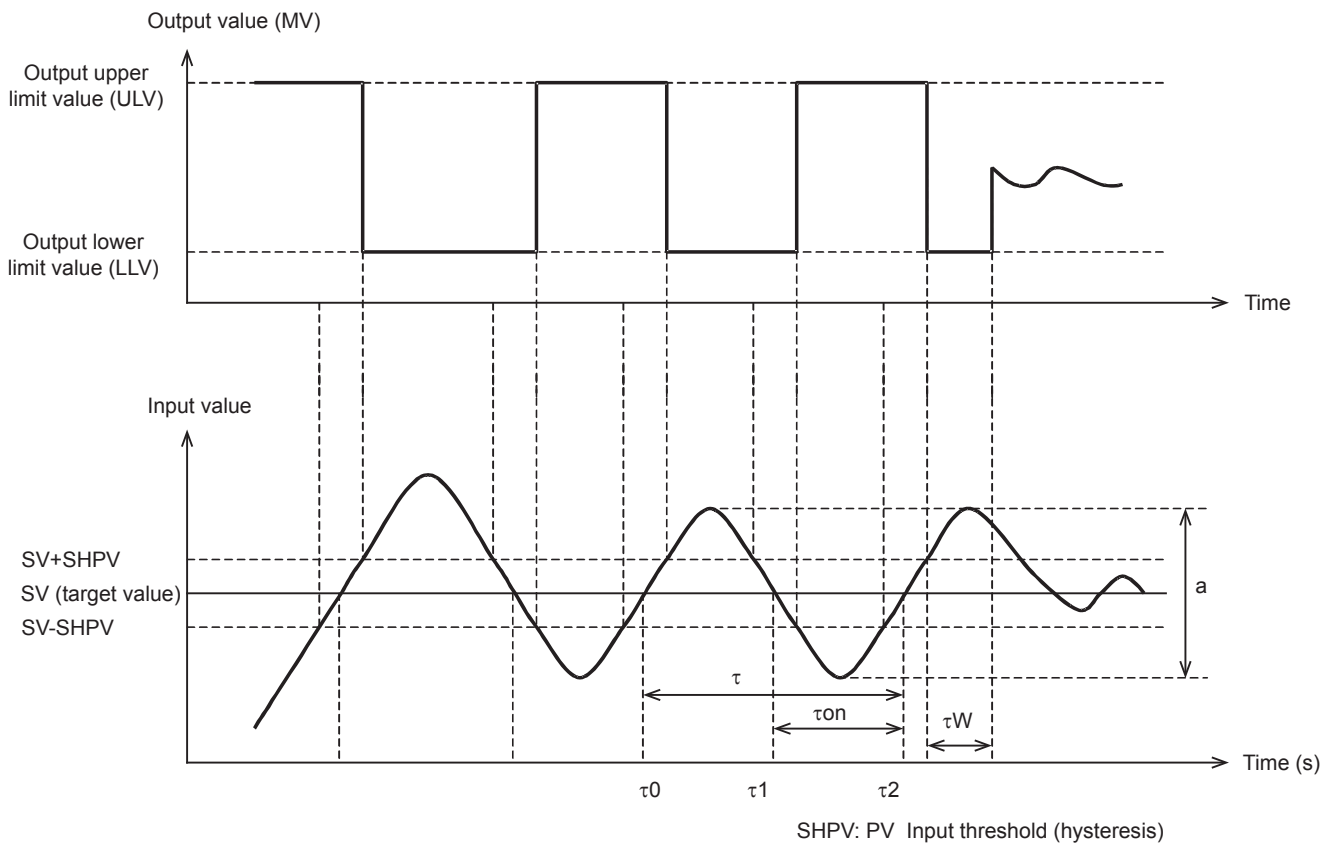

Parameters set in limit cycle method

The parameters specified in the limit cycle method are shown below.

Parameter	Setting position
Proportional gain (KP)	(s3)+3
Integral time (TI)	(s3)+4
Differential time (TD)	(s3)+6

Auto-tuning procedure

1. Set forward or backward operation

Set the operation direction flag (b0) in the operation setting parameter (ACT) (s3)+1.

2. Select the auto-tuning method (limit cycle method)

Set the auto-tuning method to ON (b6) in the operation setting parameter (ACT) (s3)+1. (When bit 6 is set to OFF, the step response method is selected.)

3. Set the auto-tuning execution flag to ON

Set the auto-tuning execution flag to ON (b4) in the operation setting parameter (ACT) (s3)+1.

4. Set the input filter

Set the input filter in the operation setting parameter (ACT) (s3)+2.

5. Set the sampling time

Set the sampling time (s3).

6. Set the Upper Limit Value (ULV)

Set the Upper Limit Value (ULV) of the output value (MV) in the operation setting parameter (ACT) (s3)+26.

7. Set the Lower Limit Value (LLV)

Set the Lower Limit Value (LLV) of the output value (MV) in the operation setting parameter (ACT) (s3)+27.

8. Set the threshold (hysteresis) (SHPV)

Set the threshold (hysteresis) width (SHPV) in the operation setting parameter (ACT) (s3)+25.

9. Set the target value (SV)

Set the target value (SV) in PID instruction.

10. Set the PID instruction command input ON to start auto-tuning

Auto-tuning is executed according to the measured value (PV).

When auto-tuning is completed, the auto-tuning flag (b4 and b6) turns OFF in the operation setting parameter (ACT) (s3)+1.

Step Response Method

For acquiring satisfactory control results during PID control, it is necessary to obtain the optimal value of each constant (parameter) suitable for the control target. This paragraph explains the step response method to obtain three constants in the PID control (proportional gain (KP), integral time (TI) and differential time (TD)).

In this method, by giving stepped output from 0 to 100 % to the control system, three constants in the PID control are obtained from the operation characteristics (maximum ramp (R) and dead time (L)) and the input value variation. The stepped output may be obtained from 0 to 75% or from 0 to 50 %.

How to obtain three constants in PID control (Reference)

■Operation characteristics and three constants

Control type	Proportional gain (KP) [%]	Integral time (TI) [$\times 100$ ms]	Differential time (TD) [$\times 10$ ms]
Only proportional control (P operation)	$\frac{1}{RL} \times \text{Output value (MV)} \times 100$	—	—
PI control (PI operation)	$\frac{0.9}{RL} \times \text{Output value (MV)} \times 100$	33L	—
PID control (PID operation)	$\frac{1.2}{RL} \times \text{Output value (MV)} \times 100$	20L	50L

■Operation characteristics

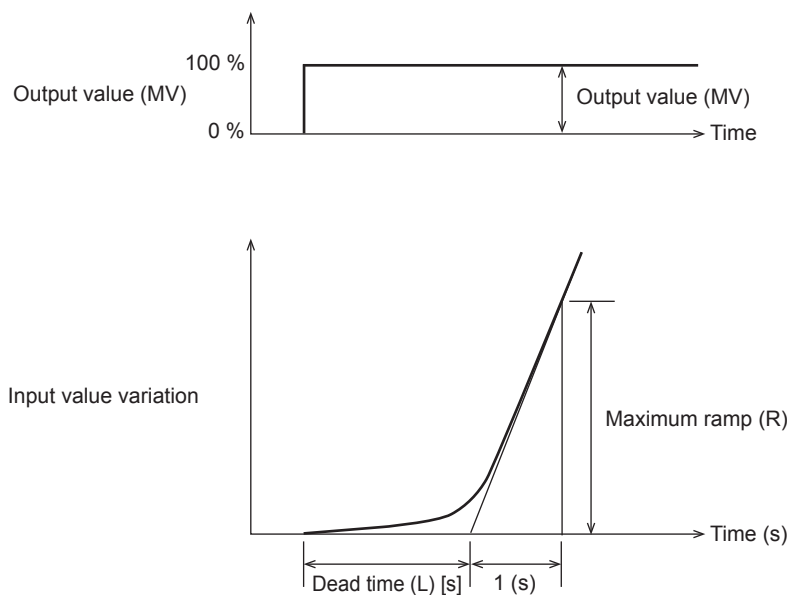

Parameters set in step response method

The parameters specified in the step response method are shown below.

Parameter	Setting position
Operation setting (ACT)	(s3)+3: b0 (operation direction)
Proportional gain (KP)	(s3)+3
Integral time (TI)	(s3)+4
Differential time (TD)	(s3)+6

Auto-tuning procedure

1. Transferring the output value for auto-tuning to the output value (d)

Set the output value for auto-tuning to the maximum available output value multiplied by 0.5 to 1 for the output equipment.

2. Setting the parameter (s3), target value (SV), etc. that cannot be set in autotuning according to the system

3. Setting to ON b4 of (s3)+1 (operation setting ACT) to start auto-tuning

When the variation from the measured value at the start of auto-tuning to the target value reaches 1/3 or more, auto-tuning is completed. And bit 4 of (s3)+1 (operation setting ACT) is automatically set to OFF.

Point

Start auto-tuning while the system is stable.

If the system is unstable when auto-tuning is started, auto-tuning may not be executed normally.

Cautions on auto-tuning setting

Note that auto-tuning may not be executed normally if the cautions described below are not followed

- Difference between the target value (SV) and the measured value (PV)

If the difference between the target value (SV) and the measured value (PV) is less than 150 when autotuning is started, auto-tuning is not executed normally. Accordingly, if the difference is less than 150, set the target value for auto-tuning. Set the target value again when auto-tuning is completed.

- Sampling time (TS)

Make sure the sampling time is set for auto-tuning to 1 second (1000 ms) or more. It is recommended that the sampling time is set to that it is considerably longer than the output change cycle.

Cautions on auto-tuning execution

■ Program countermeasures when the input value (PV) does not change

When the input value (PV) does not change normally due to factors such as wire breakage in an analog input line, auto-tuning is not finished. Detect and avoid such occurrences by introducing a sequence to monitor the input value or the elapsed time from the start of auto-tuning.

9.8 Examples of Program

System configuration example

An example of the system configuration when the PID control function is used is shown below.

System configuration

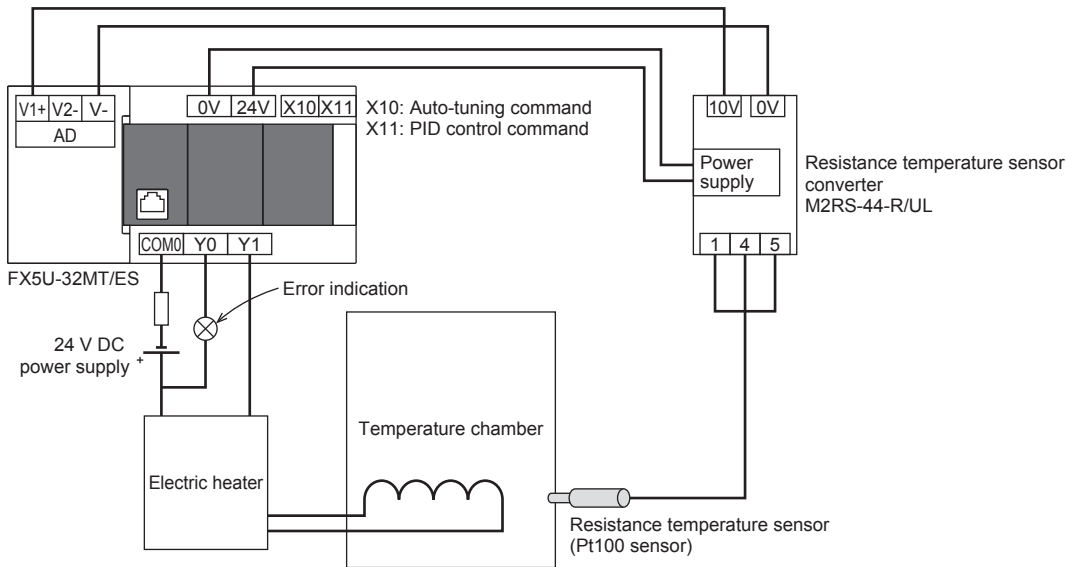

Operation of the electric heater

■During PID control

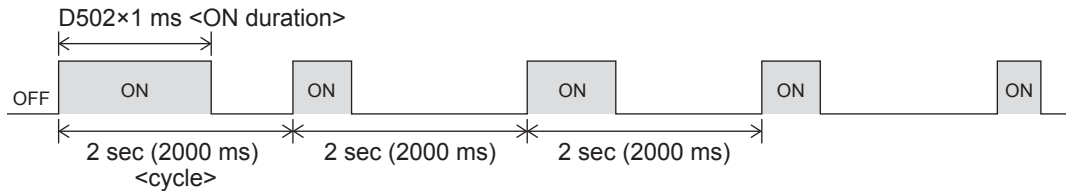

■During auto-tuning

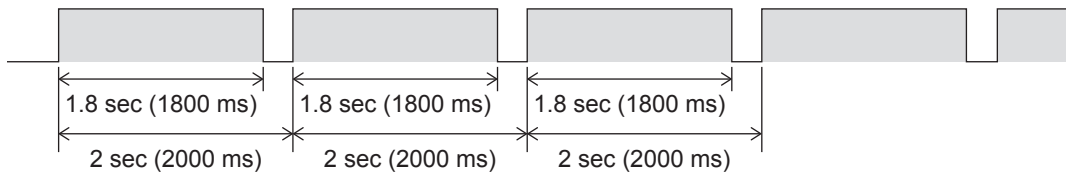

Program examples

Program example	Description	Reference
Program example 1	This is an example of the sample program for PID control.	Page 74
Program example 2	This is an example of the sample program for auto tuning (limit cycle method).	Page 76
Program example 3	This is an example of the sample program for auto tuning (step response method).	Page 78
Program example 4	This is an example of the sample program for auto tuning (limit cycle method) + PID control.	Page 80
Program example 5	This is an example of the sample program for auto tuning (step response method) + PID control.	Page 82

Program example 1

This is an example of the sample program for PID control.

Use device

The content of the devices used for the program is as follows.

Item		Device	Setting value			
			During auto-tuning	During PID control		
Target value (SV) ^{*1}		(s1)	D500	Not used	5000 (50.0°C)	
Measured value (PV) ^{*1}		(s2)	SD6022	Not used	According to input value ^{*2}	
Parameter	Sampling time (TS) ^{*1}	(s3)	D510	Not used	500 (500 ms)	
	Operation setting (ACT)	Operation direction ^{*1}	(s3)+1 b0	D511.0	Not used	1 (Backward operation)
		Input variation alarm	(s3)+1 b1	D511.1	Not used	0 (Alarm is not provided)
		Output variation alarm	(s3)+1 b2	D511.2	Not used	0 (Alarm is not provided)
		Auto-tuning	(s3)+1 b4	D511.4	Not used	0 (AT is not provided)
		Upper and lower limits of output value	(s3)+1 b5	D511.5	Not used	1 (Setting is provided)
		Select auto-tuning mode	(s3)+1 b6	D511.6	Not used	Not used
	Input filter constant (α)		(s3)+2	D512	Not used	0 (Input filter is not provided)
	Proportional gain (KP) ^{*1}		(s3)+3	D513	Not used	3000 (3000 %)
	Integral time (TI) ^{*1}		(s3)+4	D514	Not used	2000 (2000×100 ms)
	Differential gain (KD)		(s3)+5	D515	Not used	0 (Differential gain is not provided)
	Differential time (TD) ^{*1}		(s3)+6	D516	Not used	5000 (5000×10 ms)
	Input variation (incremental) alarm set value		(s3)+20	D530	Not used	Not used
	Input variation (decremental) alarm set value		(s3)+21	D531	Not used	Not used
	Output variation (incremental) alarm set value		(s3)+22	D532	Not used	2000 (2 second)
	Output upper limit set value					
	Output variation (decremental) alarm set value		(s3)+23	D533	Not used	0 (0 second)
	Output lower limit set value					
	Alarm output	Input variation (incremental) is exceeded	(s3)+24 b0	D534.0	Not used	Not used
		Input variation (decremental) is exceeded	(s3)+24 b1	D534.1	Not used	Not used
Output variation (incremental) is exceeded		(s3)+24 b2	D534.2	Not used	Not used	
Output variation (decremental) is exceeded		(s3)+24 b3	D534.3	Not used	Not used	
PV value threshold (hysteresis) width (SHPV)		(s3)+25	D535	—	—	
Output value upper limit (ULV)		(s3)+26	D536	—	—	
Output value lower limit (LLV)		(s3)+27	D537	—	—	
Wait setting from end of tuning cycle to start of PID control (KW)		(s3)+28	D538	—	—	
Output value (MV) ^{*1}		(d)	D502	Not used	According to operation	

—: This is an item not occupied.

*1 The setting is always necessary.

*2 When CH1 is used.

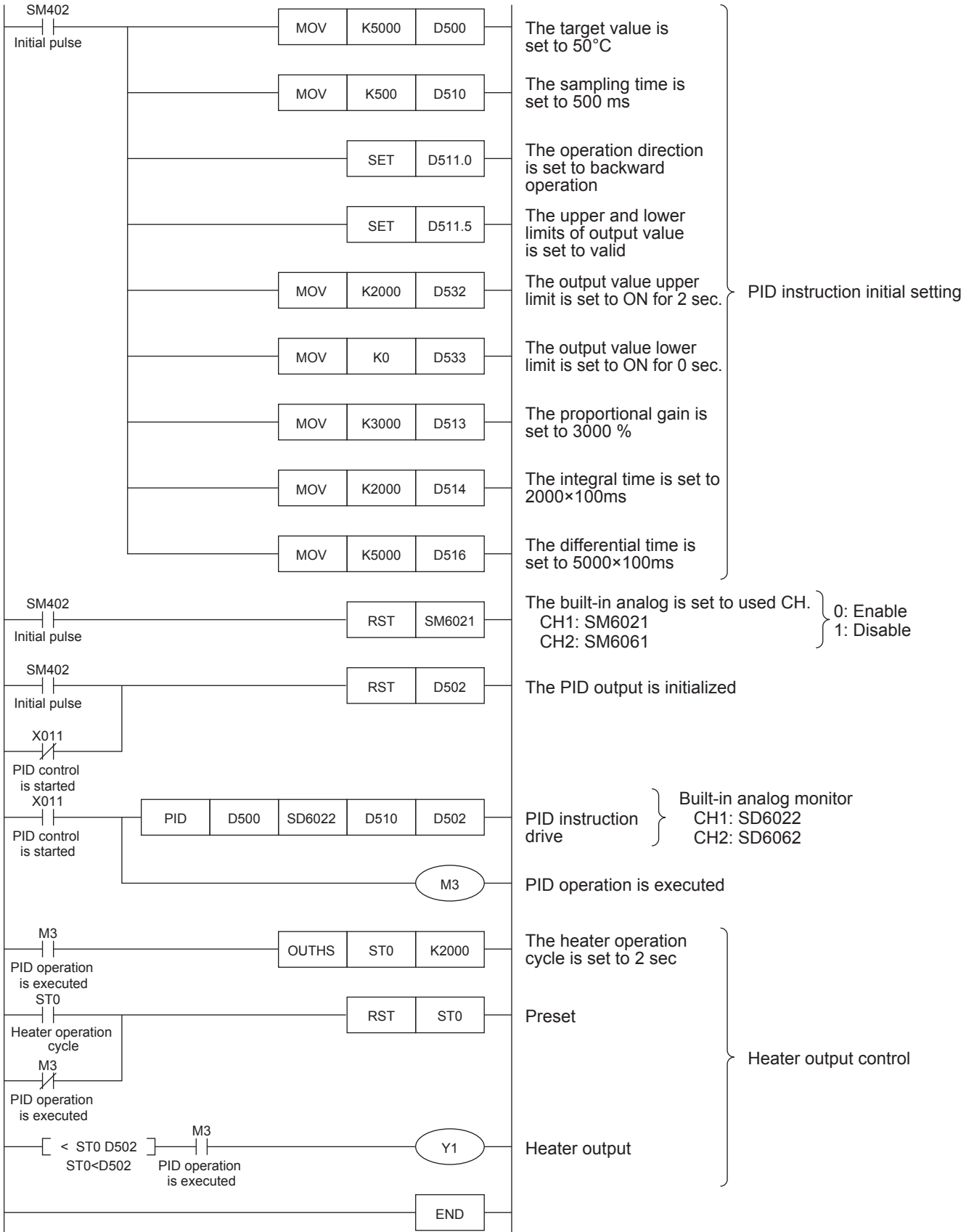

Program example 2

This is an example of the sample program for auto tuning (limit cycle method).

Use device

The content of the devices used for the program is as follows.

Item		Device	Setting value		
			During auto-tuning	During PID control	
Target value (SV) ^{*1}		(s1)	D500	5000 (50.0°C)	Not used
Measured value (PV) ^{*1}		(s2)	SD6022	According to input value	Not used ^{*2}
Parameter	Sampling time (TS) ^{*1}	(s3)	D510	500 (500 ms)	Not used
	Operation setting (ACT)	Operation direction ^{*1}	(s3)+1 b0	D511.0	1 (Backward operation)
Input variation alarm		(s3)+1 b1	D511.1	0 (Alarm is not provided)	Not used
Output variation alarm		(s3)+1 b2	D511.2	0 (Alarm is not provided)	Not used
Auto-tuning		(s3)+1 b4	D511.4	1 (AT is provided)	Not used
Upper and lower limits of output value		(s3)+1 b5	D511.5	0 (Setting is not provided)	Not used
Select auto-tuning mode		(s3)+1 b6	D511.6	1 (Limit cycle method)	Not used
Input filter constant (α)		(s3)+2	D512	0 (Input filter is not provided)	Not used
Proportional gain (KP) ^{*1}		(s3)+3	D513	According to auto-tuning result	Not used
Integral time (TI) ^{*1}		(s3)+4	D514	According to auto-tuning result	Not used
Differential gain (KD)		(s3)+5	D515	0 (Differential gain is not provided)	Not used
Differential time (TD) ^{*1}		(s3)+6	D516	According to auto-tuning result	Not used
Input variation (incremental) alarm set value		(s3)+20	D530	Not used	Not used
Input variation (decremental) alarm set value		(s3)+21	D531	Not used	Not used
Output variation (incremental) alarm set value		(s3)+22	D532	Not used	Not used
Output upper limit set value					
Output variation (decremental) alarm set value		(s3)+23	D533	Not used	Not used
Output lower limit set value					
Alarm output	Input variation (incremental) is exceeded	(s3)+24 b0	D534.0	Not used	Not used
	Input variation (decremental) is exceeded	(s3)+24 b1	D534.1	Not used	Not used
	Output variation (incremental) is exceeded	(s3)+24 b2	D534.2	Not used	Not used
	Output variation (decremental) is exceeded	(s3)+24 b3	D534.3	Not used	Not used
PV value threshold (hysteresis) width (SHPV)		(s3)+25	D535	500 (5.0°C)	Not used
Output value upper limit (ULV)		(s3)+26	D536	2000 (2 second)	Not used
Output value lower limit (LLV)		(s3)+27	D537	0 (0 second)	Not used
Wait setting from end of tuning cycle to start of PID control (KW)		(s3)+28	D538	-50 (Wait is not provided)	Not used
Output value (MV) ^{*1}		(d)	D502	According to operation	Not used

—: This is an item not occupied.

*1 The setting is always necessary.

*2 When CH1 is used.

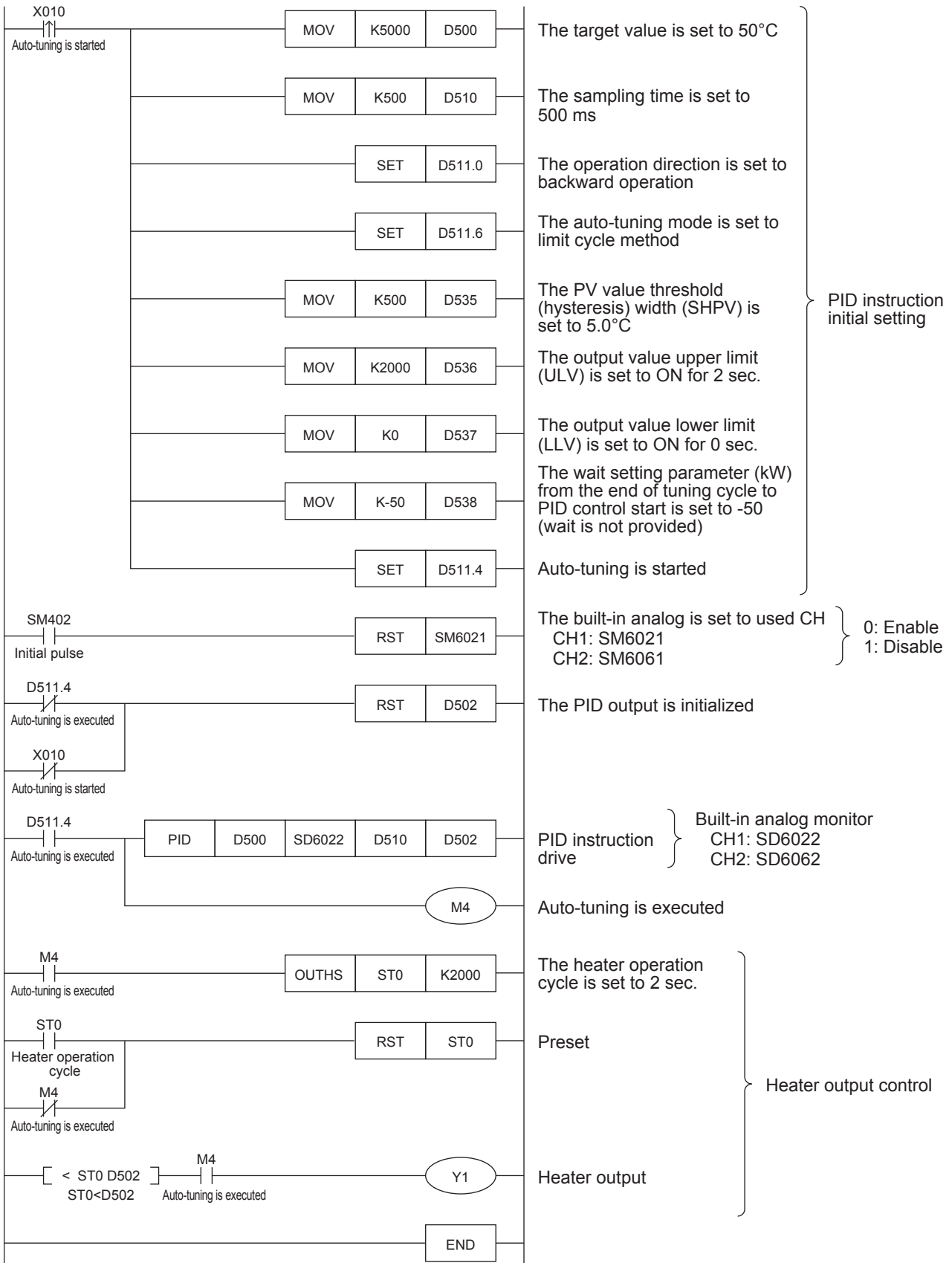

Program example 3

This is an example of the sample program for auto tuning (step response method).

Use device

The content of the devices used for the program is as follows.

Item		Device	Setting value		
			During auto-tuning	During PID control	
Target value (SV) ^{*1}		(s1)	D500	5000 (50.0°C)	Not used
Measured value (PV) ^{*1}		(s2)	SD6022	According to input value	Not used ^{*2}
Parameter	Sampling time (TS) ^{*1}	(s3)	D510	500 (500 ms)	Not used
	Operation setting (ACT)	Operation direction ^{*1}	(s3)+1 b0	D511.0	According to auto-tuning result
Input variation alarm		(s3)+1 b1	D511.1	0 (Alarm is not provided)	Not used
Output variation alarm		(s3)+1 b2	D511.2	0 (Alarm is not provided)	Not used
Auto-tuning		(s3)+1 b4	D511.4	1 (AT is provided)	Not used
Upper and lower limits of output value		(s3)+1 b5	D511.5	0 (Setting is not provided)	Not used
Select auto-tuning mode		(s3)+1 b6	D511.6	0 (Step response method)	Not used
Input filter constant (α)		(s3)+2	D512	0 (Input filter is not provided)	Not used
Proportional gain (KP) ^{*1}		(s3)+3	D513	According to auto-tuning result	Not used
Integral time (TI) ^{*1}		(s3)+4	D514	According to auto-tuning result	Not used
Differential gain (KD)		(s3)+5	D515	0 (Differential gain is not provided)	Not used
Differential time (TD) ^{*1}		(s3)+6	D516	According to auto-tuning result	Not used
Input variation (incremental) alarm set value		(s3)+20	D530	Not used	Not used
Input variation (decremental) alarm set value		(s3)+21	D531	Not used	Not used
Output variation (incremental) alarm set value		(s3)+22	D532	Not used	Not used
Output upper limit set value					
Output variation (decremental) alarm set value		(s3)+23	D533	Not used	Not used
Output lower limit set value					
Alarm output	Input variation (incremental) is exceeded	(s3)+24 b0	D534.0	Not used	Not used
	Input variation (decremental) is exceeded	(s3)+24 b1	D534.1	Not used	Not used
	Output variation (incremental) is exceeded	(s3)+24 b2	D534.2	Not used	Not used
	Output variation (decremental) is exceeded	(s3)+24 b3	D534.3	Not used	Not used
PV value threshold (hysteresis) width (SHPV)		(s3)+25	D535	—	Not used
Output value upper limit (ULV)		(s3)+26	D536	—	Not used
Output value lower limit (LLV)		(s3)+27	D537	—	Not used
Wait setting from end of tuning cycle to start of PID control (KW)		(s3)+28	D538	—	Not used
Output value (MV) ^{*1}		(d)	D502	1800 (1.8 second)	Not used

—: This is an item not occupied.

*1 The setting is always necessary.

*2 When CH1 is used.

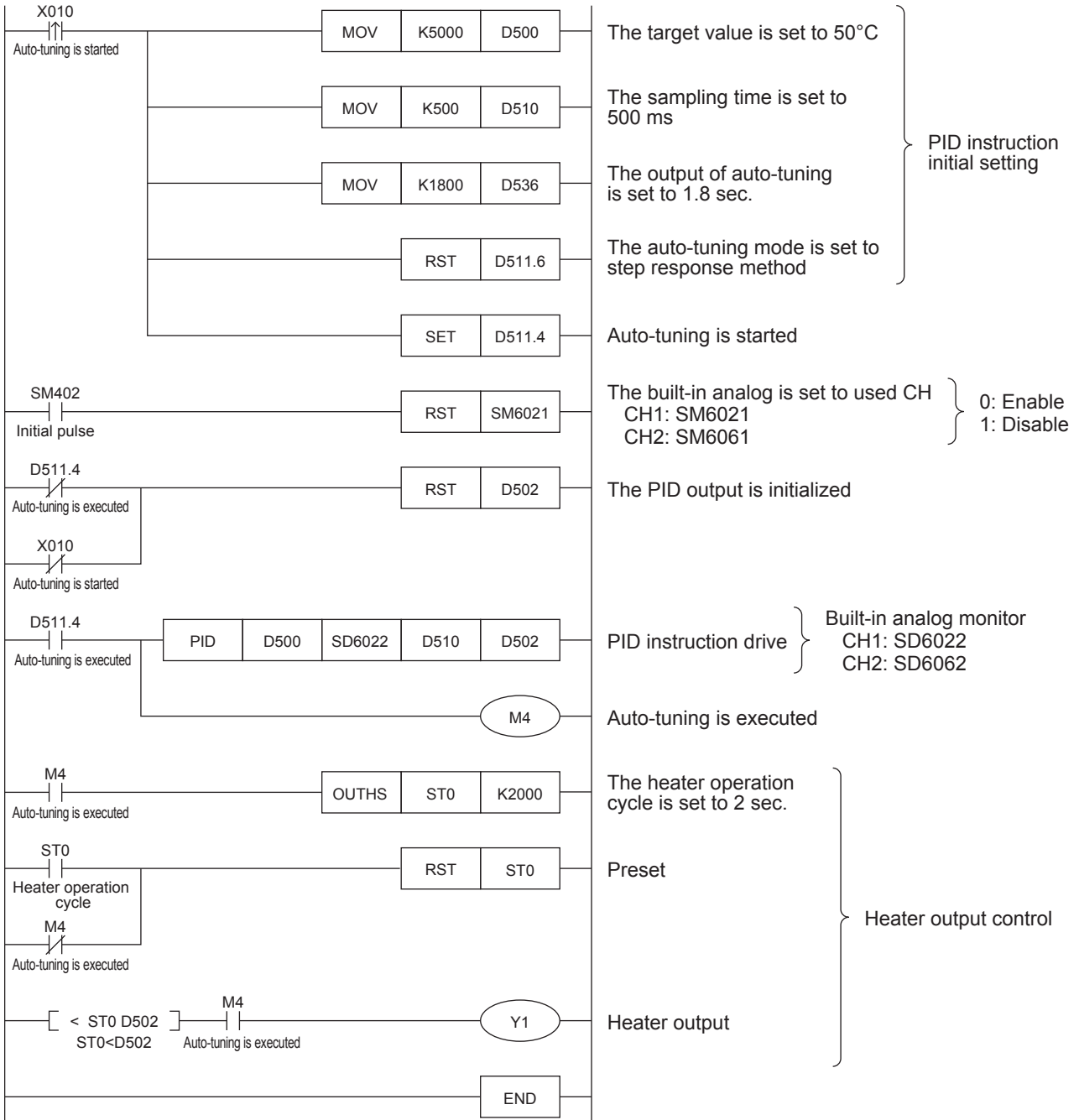

Program example 4

This is an example of the sample program for auto tuning (limit cycle method) + PID control.

Use device

The content of the devices used for the program is as follows.

Item		Device	Setting value			
			During auto-tuning	During PID control		
Target value (SV) ^{*1}		(s1)	D500	5000 (50.0°C)	5000 (50.0°C)	
Measured value (PV) ^{*1}		(s2)	SD6022	According to input value	According to input value ^{*2}	
Parameter	Sampling time (TS) ^{*1}	(s3)	D510	500 (500 ms)	500 (500 ms)	
	Operation setting (ACT)	Operation direction ^{*1}	(s3)+1 b0	D511.0	1 (Backward operation)	1 (Backward operation)
		Input variation alarm	(s3)+1 b1	D511.1	0 (Alarm is not provided)	0 (Alarm is not provided)
		Output variation alarm	(s3)+1 b2	D511.2	0 (Alarm is not provided)	0 (Alarm is not provided)
		Auto-tuning	(s3)+1 b4	D511.4	1 (AT is provided)	1 (AT is provided)
		Upper and lower limits of output value	(s3)+1 b5	D511.5	0 (Setting is not provided)	1 (Setting is provided)
		Select auto-tuning mode	(s3)+1 b6	D511.6	1 (Limit cycle method)	Not used
	Input filter constant (α)	(s3)+2	D512	0 (Input filter is not provided)	0 (Input filter is not provided)	
	Proportional gain (KP) ^{*1}	(s3)+3	D513	According to auto-tuning result	According to auto-tuning result	
	Integral time (TI) ^{*1}	(s3)+4	D514	According to auto-tuning result	According to auto-tuning result	
	Differential gain (KD)	(s3)+5	D515	0 (Differential gain is not provided)	0 (Differential gain is not provided)	
	Differential time (TD) ^{*1}	(s3)+6	D516	According to auto-tuning result	According to auto-tuning result	
	Input variation (incremental) alarm set value	(s3)+20	D530	Not used	Not used	
	Input variation (decremental) alarm set value	(s3)+21	D531	Not used	Not used	
	Output variation (incremental) alarm set value Output upper limit set value	(s3)+22	D532	Not used	2000 (2 second)	
	Output variation (decremental) alarm set value Output lower limit set value	(s3)+23	D533	Not used	0 (0 second)	
	Alarm output	Input variation (incremental) is exceeded	(s3)+24 b0	D534.0	Not used	Not used
		Input variation (decremental) is exceeded	(s3)+24 b1	D534.1	Not used	Not used
		Output variation (incremental) is exceeded	(s3)+24 b2	D534.2	Not used	Not used
		Output variation (decremental) is exceeded	(s3)+24 b3	D534.3	Not used	Not used
PV value threshold (hysteresis) width (SHPV)	(s3)+25	D535	500 (5.0°C)	Not used		
Output value upper limit (ULV)	(s3)+26	D536	2000 (2 second)	Not used		
Output value lower limit (LLV)	(s3)+27	D537	0 (0 second)	Not used		
Wait setting from end of tuning cycle to start of PID control (KW)	(s3)+28	D538	-50 (Wait is not provided)	Not used		
Output value (MV) ^{*1}		(d)	D502	According to operation	According to operation	

—: This is an item not occupied.

*1 The setting is always necessary.

*2 When CH1 is used.

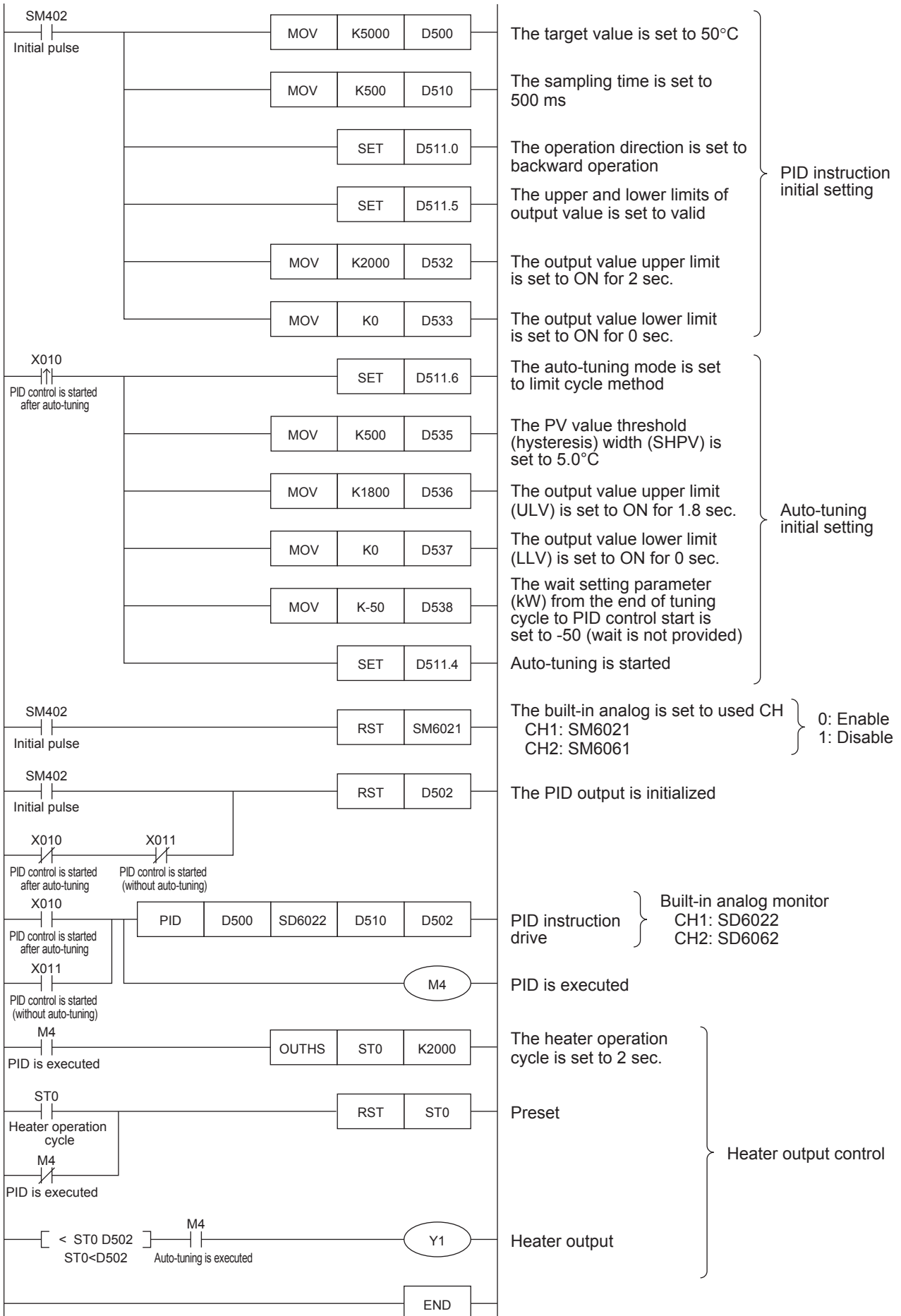

Program example 5

This is an example of the sample program for auto tuning (step response method) + PID control.

Use device

The content of the devices used for the program is as follows.

Item		Device	Setting value			
			During auto-tuning	During PID control		
Target value (SV) ^{*1}		(s1)	D500	5000 (50.0°C)	5000 (50.0°C)	
Measured value (PV) ^{*1}		(s2)	SD6022	According to input value	According to input value ^{*2}	
Parameter	Sampling time (TS) ^{*1}	(s3)	D510	500 (500 ms)	500 (500 ms)	
	Operation setting (ACT)	Operation direction ^{*1}	(s3)+1 b0	D511.0	According to auto-tuning result	According to auto-tuning result
		Input variation alarm	(s3)+1 b1	D511.1	0 (Alarm is not provided)	0 (Alarm is not provided)
		Output variation alarm	(s3)+1 b2	D511.2	0 (Alarm is not provided)	0 (Alarm is not provided)
		Auto-tuning	(s3)+1 b4	D511.4	1 (AT is provided)	0 (AT is not provided)
		Upper and lower limits of output value	(s3)+1 b5	D511.5	0 (Setting is not provided)	Not used
		Select auto-tuning mode	(s3)+1 b6	D511.6	0 (Step response method)	Not used
	Input filter constant (α)	(s3)+2	D512	0 (Input filter is not provided)	0 (Input filter is not provided)	
	Proportional gain (KP) ^{*1}	(s3)+3	D513	According to auto-tuning result	According to auto-tuning result	
	Integral time (TI) ^{*1}	(s3)+4	D514	According to auto-tuning result	According to auto-tuning result	
	Differential gain (KD)	(s3)+5	D515	0 (Differential gain is not provided)	0 (Differential gain is not provided)	
	Differential time (TD) ^{*1}	(s3)+6	D516	According to auto-tuning result	According to auto-tuning result	
	Input variation (incremental) alarm set value	(s3)+20	D530	Not used	Not used	
	Input variation (decremental) alarm set value	(s3)+21	D531	Not used	Not used	
	Output variation (incremental) alarm set value	(s3)+22	D532	Not used	2000 (2 second)	
	Output variation (decremental) alarm set value	(s3)+23	D533	Not used	0 (0 second)	
	Alarm output	Input variation (incremental) is exceeded	(s3)+24 b0	D534.0	Not used	Not used
		Input variation (decremental) is exceeded	(s3)+24 b1	D534.1	Not used	Not used
		Output variation (incremental) is exceeded	(s3)+24 b2	D534.2	Not used	Not used
		Output variation (decremental) is exceeded	(s3)+24 b3	D534.3	Not used	Not used
PV value threshold (hysteresis) width (SHPV)	(s3)+25	D535	—	Not used		
Output value upper limit (ULV)	(s3)+26	D536	—	Not used		
Output value lower limit (LLV)	(s3)+27	D537	—	Not used		
Wait setting from end of tuning cycle to start of PID control (KW)	(s3)+28	D538	—	Not used		
Output value (MV) ^{*1}		(d)	D502	1800 (1.8 second)	According to operation	

—: This is an item not occupied.

*1 The setting is always necessary.

*2 When CH1 is used.

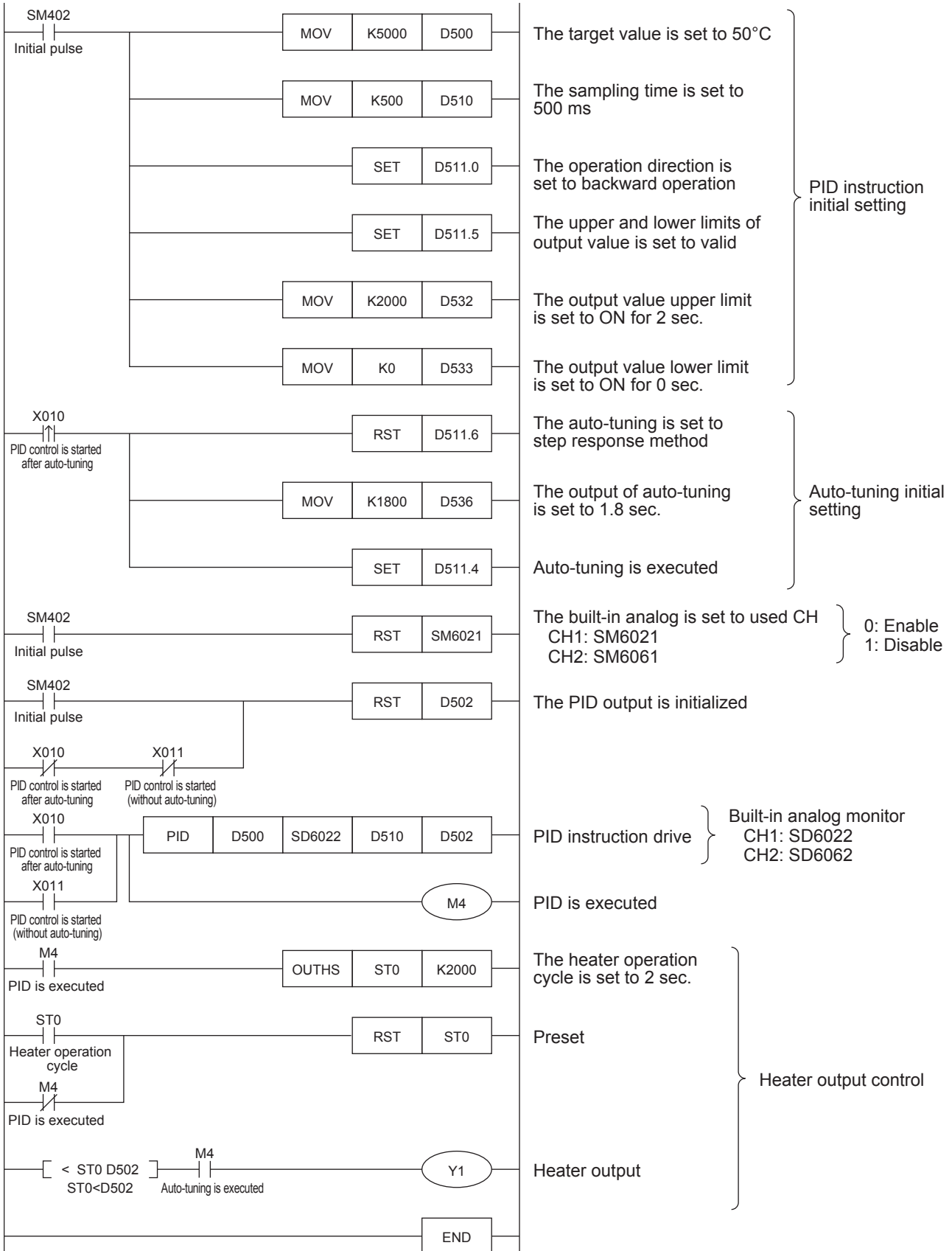

10 CONSTANT SCAN

Since the processing time differs as per the execution/non-execution of command used in the program, the scan timer changes with every scan. By setting the constant scan, because a program can be repeatedly executed while keeping scan time at a specified amount of time, even when the execution time of the program changes, the I/O refresh interval can be constant.

- When constant scan is set (Settings value=10 ms)

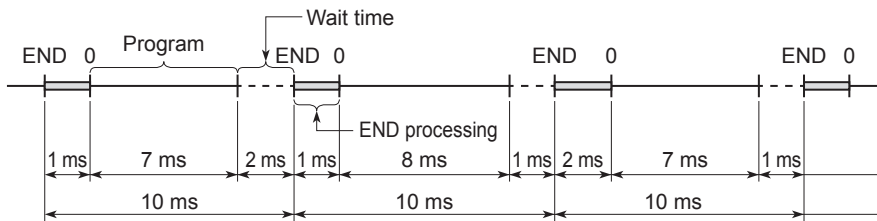

- When constant scan time is not set

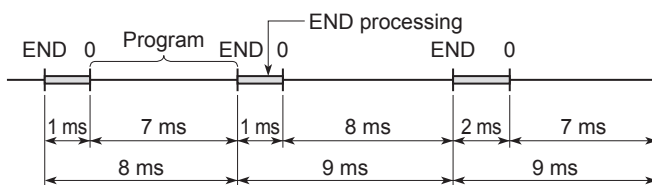

10.1 Constant scan settings

Sets the constant scan setting.

Navigation window ⇒ [Parameter] ⇒ [FX5UCPU] ⇒ [CPU Parameter] ⇒ "RAS Setting" ⇒ "Constant Scan Setting"

Window

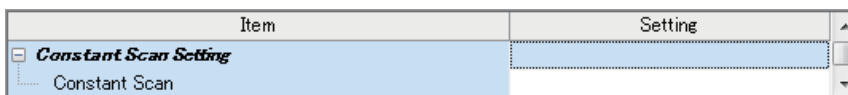

Displayed items

Item	Description	Setting range	Default
Constant Scan	Sets the constant scan time.	0.2 to 2000 ms (0.1 ms units)	—

Conditions of setting time

Set a value that meets the following relational equation for the setting time of the constant scan.

"WDT setting time" > "Constant scan setting time" > "Maximum scan time of the program"

When the maximum scan time of the program is longer than the setting time of the constant scan, it results in error. The constant scan time is ignored and it is executed with the scan time of the program.

Ex.

When the constant scan time is set to 4 ms

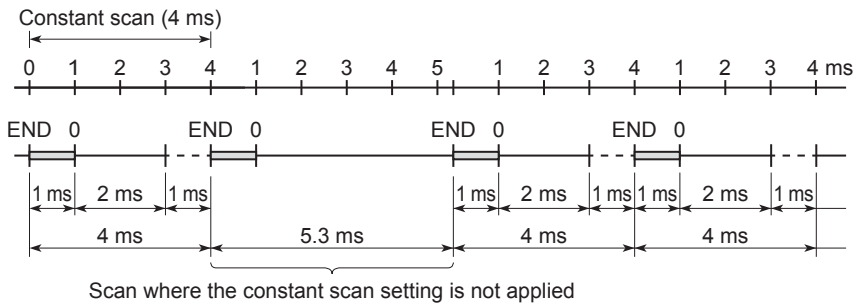

Wait time from the execution of END process until the beginning of the next scan

When there is a processing mentioned below requested during wait time, the processing of the program is interrupted and the corresponding process is carried out.

- Interrupt program
- Event execution type program which triggers the generation of interruption
- Device/label access service processing

11 REMOTE OPERATION

A remote operation is an operation to externally change the operation status of the CPU module with the RUN/STOP/RESET switch of the CPU module set to the RUN position.

The following items show the types of remote operation.

- Remote RUN/STOP
- Remote PAUSE
- Remote RESET

11.1 Remote RUN/STOP

This operation externally changes the CPU module to RUN/STOP status with the RUN/STOP/RESET switch of the CPU module set to the RUN position. It is used to reach a CPU module in an inaccessible place or in case of changing the status of the CPU module in the control box to RUN/STOP status with an external signal.

Applications of remote RUN/STOP

It is usable in the following cases.

- When the CPU module is in an inaccessible place
- When changing the status of the CPU module in the control box to RUN/STOP from outside

Operation during remote RUN/STOP

In case of remote RUN/STOP, the operation of the program is as shown below.

At remote STOP

A program is executed up-to END instruction and changes to STOP status.

At remote RUN

When remote RUN is executed in the STOP status, once again the CPU module turns to RUN status and the program is executed from step 0.

Method of execution of remote RUN/STOP

The following are the methods of execution of remote RUN/STOP.

Contact method

Set the RUN contact in the parameter. The allowable device range is X0 to X17.

Execute remote RUN/STOP by contact ON/OFF. Set the correspondence of ON/OFF and RUN/STOP operation of the contact in CPU parameters.

- When set to RUN at contact ON

When contact is set to OFF, the CPU module is in the STOP status.

When contact is set to ON, the CPU module is in the RUN status.

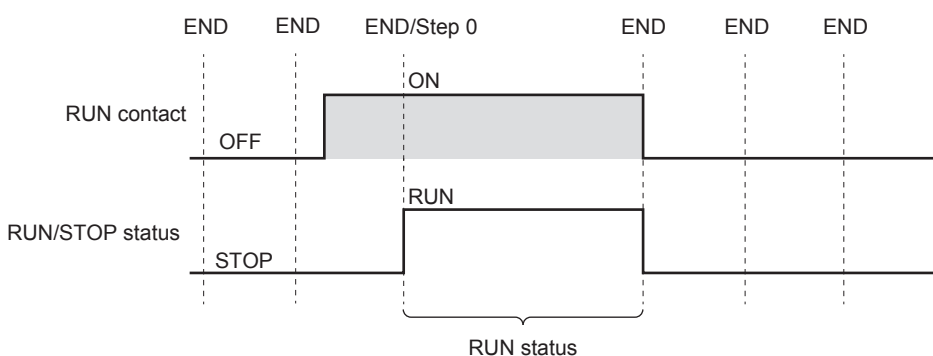

- When set to STOP at contact ON

When contact is set to OFF, the CPU module is in the RUN status.

When contact is set to ON, the CPU module is in the STOP status.

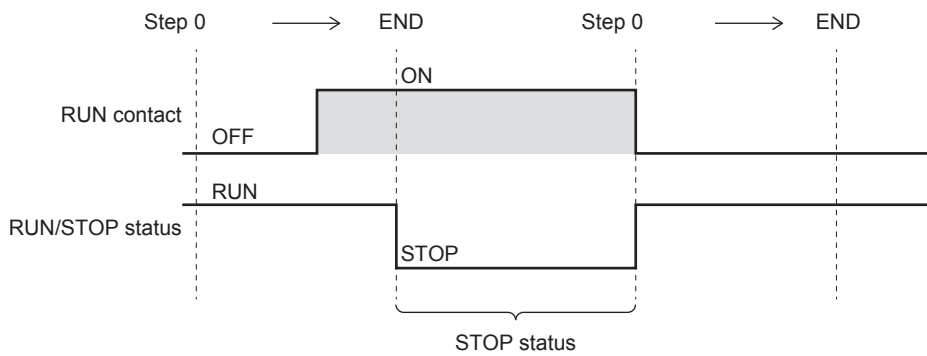

Engineering tool method

Refer to the following.

GX Works3 Operating Manual

Method using external devices that use SLMP

Execute by SLMP command. For details on commands, refer to the following manual.

MELSEC iQ-F FX5 User's Manual (SLMP)

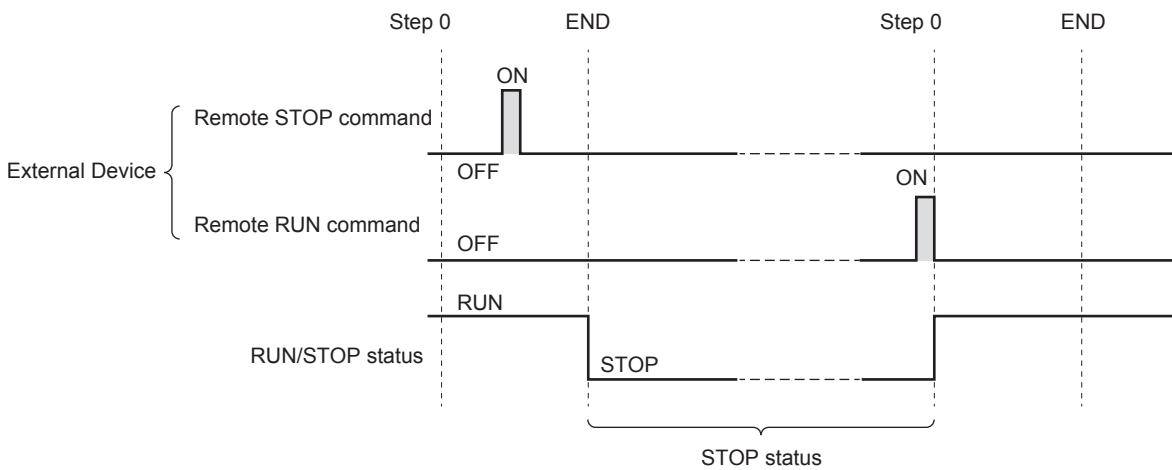

11.2 Remote PAUSE

With the RUN/STOP/RESET switch set to the RUN position of the CPU module, the operation status is changed to PAUSE status from outside. The PAUSE status is a status in which operation of the CPU module is stopped by holding the ON/OFF status of all output (Y).

Application of remote PAUSE

Remote PAUSE can be used to hold the output (Y) turned ON when the CPU module is in the RUN status, in the same ON status, even when the CPU module is changed to STOP status.

Method of execution of remote PAUSE

The following are the methods of execution of remote PAUSE.

Engineering tool method

Refer to the following.

 GX Works3 Operating Manual

Method using external devices that use SLMP

Execute by SLMP command. For details on commands, refer to the following manual.

 MELSEC iQ-F FX5 User's Manual (SLMP)

- Turns ON the PAUSE contact (SM204) when executing the END process of the scan that has received the remote PAUSE command. When a PAUSE contact is turned ON and the next scan is executed up-to the END process, the CPU module enters the PAUSE status and operation is stopped.
- When a remote RUN command is received, once again an operation of the sequence program is executed from step 0.

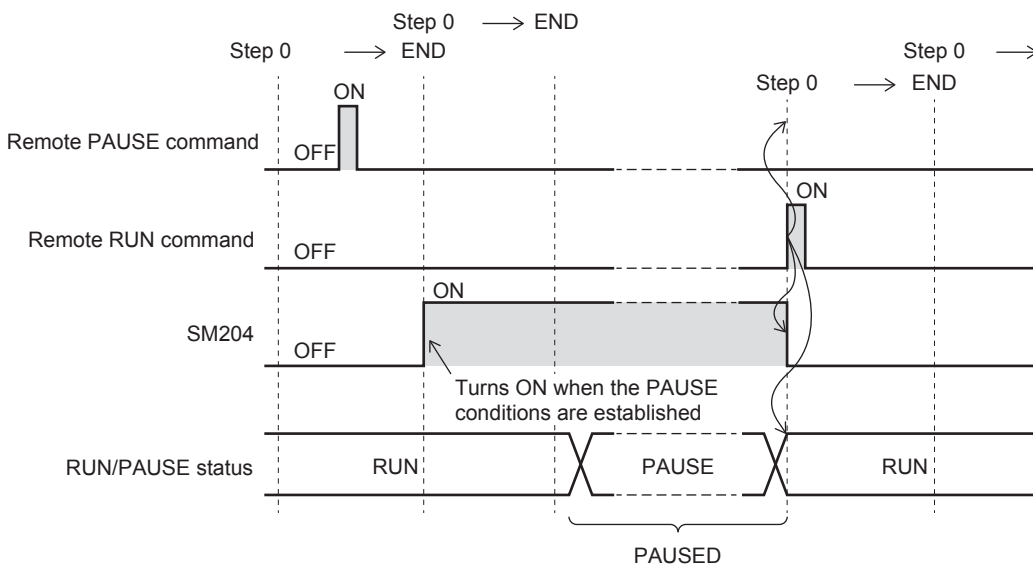

Precautions

■When keeping in forced ON or OFF status in advance

When keeping in forced ON or OFF status in advance, interlock using the PAUSE contact (SM204).

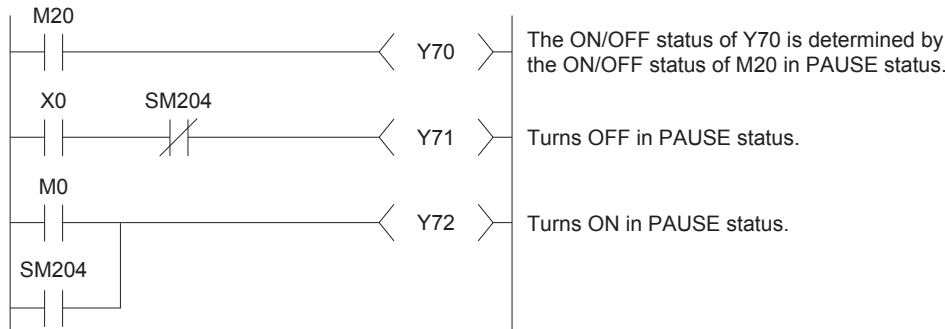

11.3 Remote RESET

This is an operation to reset the CPU module by an external operation when the CPU module is in the STOP status. In addition, even if the RUN/STOP/RESET switch of the CPU module is set to RUN position, reset is possible when the CPU module has stopped due to occurrence of an error that can be detected by self-diagnosis function.

Application of remote RESET

When a CPU module is in an inaccessible place and an error has occurred, CPU module can be reset by a remote operation.

Enabling remote RESET

To remotely RESET, remote RESET must be enabled.

Navigation window ⇒ [Parameter] ⇒ [FX5UCPU] ⇒ [CPU Parameter] ⇒ "Operation Related Setting" ⇒ "Remote Reset Setting"

Window

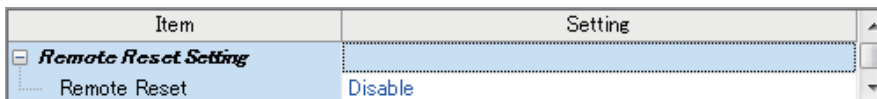

Displayed items

Item	Description	Setting range	Default
Remote Reset	Set whether or not to enable remote RESET.	<ul style="list-style-type: none"> Disable Enable 	Disable

Method of execution of remote RESET

The following are the methods of execution of remote RESET.

Engineering tool method

Refer to the following.

 GX Works3 Operating Manual

Method using external devices that use SLMP

Refer to the following.

 MELSEC iQ-F FX5 User's Manual (SLMP)

Point

When executing remote RESET, the settings that allow the remote reset of the CPU parameter must be written to CPU module beforehand. In the case that they are not set, remote RESET will not be possible.

Precautions

■ Remote RESET in RUN status

When the CPU module is in RUN status, it cannot be reset by remote RESET. Change the CPU module to STOP status by operations like remote STOP and then execute remote RESET.

■ State after completion of the reset process

When the reset process is completed on a CPU module on which remote RESET was executed, the CPU module will change to an operation status set by the RUN/STOP/RESET switch. Setting the RUN/STOP/RESET switch to the STOP position, will change the status to STOP and setting the switch to the RUN position will change the status to RUN.

Point

- Note that if a remote RESET is executed when the CPU module has stopped due to an error, the CPU module will change to an operation status set by the RUN/STOP/RESET switch, by reset process completion.
 - If status of CPU module does not change even after executing remote RESET by engineering tool, check the remote reset settings in the CPU parameter. If it is not set, even after completion of the remote process of engineering tool, reset process of the CPU module will not be carried out.
-

■ When an error occurs due to noise

When there an error due to noise, exercise caution as there is a possibility that PLC cannot be reset by remote RESET. When reset by remote RESET is not possible, either execute reset by RUN/STOP/RESET switch or once again start up the power of CPU module.

11.4 Relationship Between Remote Operation and CPU Module

Relationship between remote operation and RUN/STOP status of the CPU module

The following table shows operation status of the CPU module by the combination of remote operation and RUN/STOP status of the CPU module.

Switch RUN/STOP status	Remote operation			
	RUN ^{*1}	STOP	PAUSE	RESET ^{*2}
RUN	RUN	STOP	PAUSE	Operation not possible ^{*3}
STOP	STOP	STOP	STOP	RESET ^{*4}

*1 When executing by the RUN contact, setting of RUN contact is required in the CPU parameter.

*2 Remote reset setting is required in the CPU parameter.

*3 When a CPU module is changed to STOP status by a remote operation, remote reset is possible.

*4 Includes even the cases where CPU module has stopped due to an error.

12 DEVICE/LABEL MEMORY AREA SETTING

The capacity of each area in device/label memory can be specified.

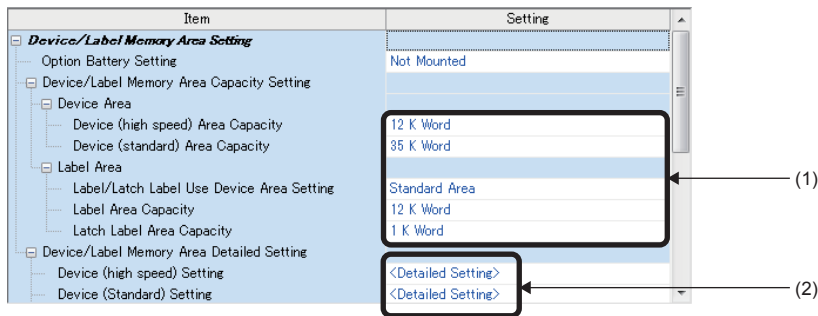

Item	Symbol	Device		Latch (1)	Latch (2)
		Points	Range		
Input	X	1024	0 to 1777		
Output	Y	1024	0 to 1777		
Internal Relay	M	7680	0 to 7679	Setting	No Setting
Link Relay	B	256	0 to FF	No Setting	No Setting
Special Link Rela SB		256	0 to FF		
Annunciator	F	128	0 to 127	No Setting	No Setting
Step Relay	S	4096	0 to 4095	Setting	
Timer	T	512	0 to 511	No Setting	No Setting
Retentive Timer	ST	16	0 to 15	Setting	No Setting
Counter	C	256	0 to 255	Setting	No Setting
Long Counter	LC	64	0 to 63	Setting	No Setting
Data Register	D	8000	0 to 7999	Setting	No Setting
Latch Relay	L	7680	0 to 7679		
Total Device			11.1K Word		9.6K Word
Total Word Device			10.2K Word		8.1K Word
Total Bit Device			15.7K Bit		25.1K Bit

(1) The capacity of each area can be changed. (☞ Page 94 Device/Label Memory Area Setting)

(2) The number of points of user devices can be changed. (☞ Page 95 Device Setting)

12.1 Default Capacity of Each Area

The default capacity of each area is as follows.

Item	Capacity
Device (high speed) Area Capacity	12 K words
Device (standard) Area Capacity	35 K words
Label Area Capacity	12 K words
Latch Label Area Capacity	1 K words

12.2 The Setting Range of the Capacity of Each Area

The setting range of the capacity of each area on the device/label memory is as follows.

Item	Setting range of capacity of each area
Device (high speed) Area Capacity	0 to 12 K words
Device (standard) Area Capacity	0 to 48 K words
Label Area Capacity	0 to 48 K words
Latch Label Area Capacity	0 to 48 K words

Restriction of a label/latch label area capacity

■When device area setting using by label/latch label is standard area

Label Area Capacity + Latch Label Area Capacity + Device (standard) Area Capacity \leq 48 K Word (1 K word unit)

■When device area setting using by label/latch label is high speed area

Label Area Capacity + Latch Label Area Capacity + Device (high speed) Area Capacity \leq 12 K Word (1 K word unit)

■When FB is used

In using FB, it consumes the margin area for a label addition in addition to the label defined for FB.

The following capacities are consumed per FB instance.

Label area: 48 words

Latch area: 16 words

12.3 Device/Label Memory Area Setting

The capacity of each data area allocated within the device/label memory can be changed.

Navigation window ⇒ [Parameter] ⇒ [FX5UCPU] ⇒ [CPU Parameter] ⇒ "Memory/Device Setting" ⇒ "Device/Label Memory Area Setting"

Operating procedure

"Device/Label Memory Area Setting" window

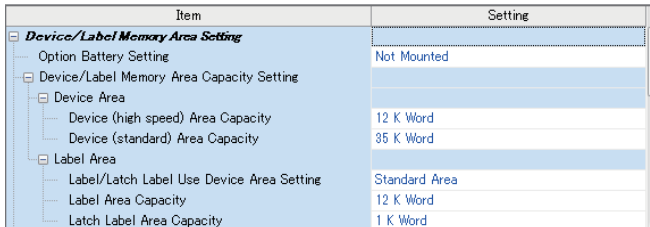

1. In "Option Battery Setting", select whether or not to use a option battery.
2. In "Device/Label Memory Area Capacity Setting", set the capacity of each area.

Displayed items

Item	Description	Setting range	Default	
Option Battery Setting	Set when using option battery. The points which can be held can be increased by this setup. The latch device of standard area can be held with a battery. The latch area of latch label can be changed to battery latch area from standard latch area (nonvolatile memory).	<ul style="list-style-type: none"> • Not Mounted • Mounted 	Not Mounted	
Device/Label Memory Area Capacity Setting	Device Area			
	Device (high speed) Area Capacity	Set the capacity of device (high speed) area.	Page 93 The Setting Range of the Capacity of Each Area	12 K word
	Device (standard) Area Capacity	Set the capacity of device (standard) area.	Page 93 The Setting Range of the Capacity of Each Area	35 K word
	Label Area	Label/Latch Label Use Device Area Setting	<ul style="list-style-type: none"> • Standard Area • HighSpeed Area 	Standard Area
	Label Area Capacity	Sets the capacity of the label area to be used for non-latched labels.	Page 93 The Setting Range of the Capacity of Each Area	12 K word
	Latch Label Area Capacity	Sets the capacity of the latch label area to be used for latch-type labels.	Page 93 The Setting Range of the Capacity of Each Area	1 K word

Point

High-speed area: Area which can be accessed at high speed. Latch is always held by nonvolatile memory.
Standard area: Area which can be held when option battery is used. In addition, about a latched type label, when a latch area is set as a standard latch area, latch type label is held by nonvolatile memory.

12.4 Device Setting

The number of points of each user device can be changed.

Navigation window ⇒ [Parameter] ⇒ [FX5UCPU] ⇒ [CPU Parameter] ⇒ "Memory/Device Setting" ⇒ "Device/Label Memory Area Setting" ⇒ "Device/Label Memory Area Detailed Setting" ⇒ "Device (high speed) Setting/Device (standard) Setting"

Window

"Device (high speed) Setting" details window

Item	Symbol	Device		Latch (1)	Latch (2)
		Points	Range		
Input	X	1024	0 to 1777		
Output	Y	1024	0 to 1777		
Internal Relay	M	7680	0 to 7679	Setting	No Setting
Link Relay	B	256	0 to FF	No Setting	No Setting
Special Link Rela SB		256	0 to FF		
Annunciator	F	128	0 to 127	No Setting	No Setting
Step Relay	S	4096	0 to 4095	Setting	
Timer	T	512	0 to 511	No Setting	No Setting
Retentive Timer	ST	16	0 to 15	Setting	No Setting
Counter	C	256	0 to 255	Setting	No Setting
Long Counter	LC	64	0 to 63	Setting	No Setting
Data Register	D	8000	0 to 7999	Setting	No Setting
Latch Relay	L	7680	0 to 7679		
Total Device			11.1K Word		9.6K Word
Total Word Device			10.2K Word		8.1K Word
Total Bit Device			15.7K Bit		25.1K Bit

"Device (standard) Setting" details window

Item	Symbol	Device		Latch (1)	Latch (2)
		Points	Range		
File Register	R	32768	0 to 32767	No Setting	No Setting
Link Register	W	512	0 to 1FF	No Setting	No Setting
Link Special Register SW		512	0 to 1FF		
Total Device			33.0K Word		0.0K Word
Total Word Device			33.0K Word		0.0K Word
Total Bit Device			0.0K Bit		0.0K Bit

Point

Specify each item so that the total number of points for each user device does not exceed the capacity of the device area. (☞ Page 94 Device/Label Memory Area Setting)

Range of use of device points

The following table lists the range of use of device points to be set in the device setting.

Device (high speed) Setting

Type	Device name	Symbol	Range of use	Increment of setting
Bit	Input	X	X0 to X1777	—
Bit	Output	Y	Y0 to Y1777	—
Bit	Internal relay	M	M0 to M32767	64 points
Bit	Link relay	B	B0 to B7FFF	64 points
Bit	Link special relay	SB	SB0 to SB7FFF	64 points
Bit	Annunciator	F	F0 to F32767	64 points
Bit	Step relay	S	S0 to S4095	—
Word	Timer	T	T0 to T1023	16 points
Word	Retentive timer	ST	ST0 to ST1023	16 points
Word	Counter	C	C0 to C1023	16 points
Word	Long counter	LC	LC0 to LC1023	16 points
Word	Data register	D	D0 to D7999	4 points
Bit	Latch relay	L	L0 to L32767	64 points

Device (standard) Setting

Type	Device name	Symbol	Range of use	Increment of setting
Word	File registers	R	R0 to R32767	4 points
Word	Link register	W	W0 to W7FFF	4 points
Word	Link special register	SW	SW0 to SW7FFF	4 points

13 INITIAL DEVICE VALUE SETTING

Directly sets the initial value of a device used by the program (i.e., not via the program).

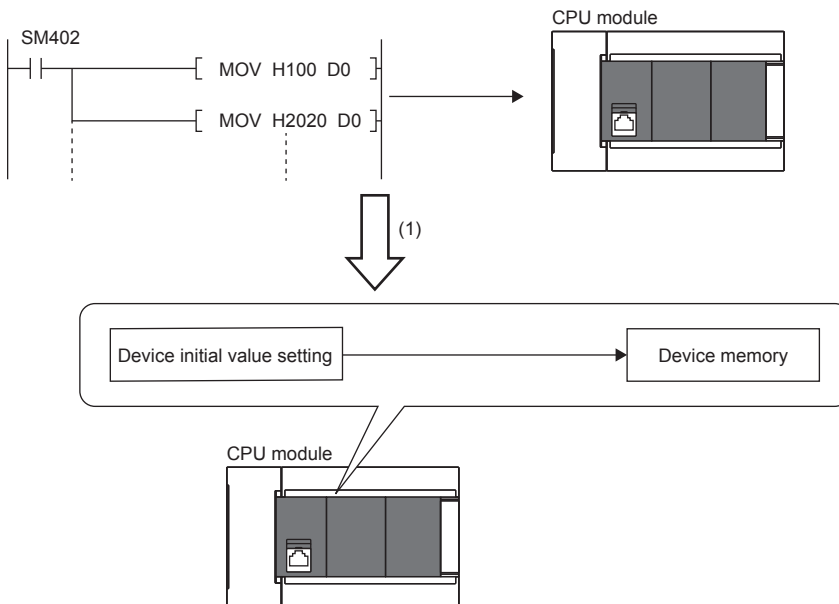

(1) If initial device values are used, a program to set data to the devices becomes unnecessary.

13.1 Setting Initial Device Values

This section describes the settings required to use initial device values.

Setting initial device values

This section describes the settings of initial device values.

Setting procedure

The procedure for using initial device values is as follows.

1. First, the user must create an initial device value file. To set initial values to a global device, create an initial device value file (with any name) which sets these initial values, and specify the range of the values.
2. On the device memory, set up initial device value data within the range specified in the initial device value file.
📖 GX Works3 Operating Manual
3. In the "Device Memory Register Diversion", select the device memory which was set up in Step 2. Setting "Device Memory Register Diversion" enables data set up on the device memory to be used as initial device values for the device which is specified in the initial device value file.
📖 GX Works3 Operating Manual
4. Configure CPU parameters. (📖 Page 98 Initial value setting)
5. Write the set initial device value file and the CPU parameters to the CPU module.
📖 GX Works3 Operating Manual
6. The data in the specified initial device value file is automatically set to the specified device when the CPU module is powered off and on, reset, or the status changes from STOP to RUN.

Initial value setting

Configure the initial value setting.

Navigation window ⇒ [Parameter] ⇒ [FX5UCPU] ⇒ [CPU Parameter] ⇒ "File Setting" ⇒ "Initial Value Setting"

Window

Item	Setting
Initial Value Setting	
Setting of Device Initial Value Use Or Not	Not Use
Target Memory	Data Memory
Global Device Initial Value File Name	

Displayed items

Item	Description	Setting range	Default
Setting of Device Initial Value Use Or Not	Sets whether or not to use initial device values.	<ul style="list-style-type: none">• Not Use• Use	Not Use
Target Memory	Sets the storage memory for the initial device value file.	<ul style="list-style-type: none">• Memory card• Data Memory	Data Memory
Global Device Initial Value File Name	Sets the name of the initial global device value file.*1	60 characters or less	—

*1 If nothing is specified, initial global device values are not applied.

Number of initial device value settings and maximum range of one range

Up to 1000 ranges can be set in one initial device value file. Up to 8000 data points can be set in one range.

13.2 Applicable Devices

For details on devices to which initial device/label values can be set, refer to the following.

 GX Works3 Operating Manual

14 LATCH FUNCTION

The contents of each device/label of the CPU module is cleared in the cases described below and changed to its default value.

- At power OFF→ON of the CPU module
- At reset
- A power failure that exceeded allowable momentary power interruption

The contents of each device/label with latch setting will be maintained in case of power failure even in the above-mentioned cases. Therefore, when the data is managed by continuous control, even if power of the CPU is turned OFF or there is a power failure that exceeds the allowable momentary power interruption, all data can be maintained and control can be continued.

14.1 Types of Latch

There are two types of latches, latch (1) and latch (2).

Latch clear range can be set by selecting latch (1) or latch (2).

For latch clearing, refer to  Page 101 Clearing of Data of the Latch Range.

14.2 Device/label that can be Latched

The devices and labels that can be latched are described below.

The devices that can be latched

The devices that can be latched are described below.

Device	Specification Method	Applicable latch type
Internal relay (M)	Specify the latch range	Latch (1) or Latch (2)
Latch relay (L)	Specify the number of points	Latch (2) only
Link relay (B)	Specify the latch range	Latch (1) or Latch (2)
Annunciator (F)	Specify the latch range	Latch (1) or Latch (2)
Step relay (S)	Specify the latch range	Latch (1) only
Timer (T)/Accumulation timer (ST)	Specify the latch range	Latch (1) or Latch (2)
Counter (C)/Long counter (LC)	Specify the latch range	Latch (1) or Latch (2)
Data register (D)	Specify the latch range	Latch (1) or Latch (2)
Link register (W) ^{*1}	Specify the latch range	Latch (1) or Latch (2)
File register (R) ^{*1}	Specify the latch range	Latch (1) or Latch (2)

*1 Link register (W) and file register (R) can be latched only when an optional battery is used.

Labels that can be latched

The labels that can be latched are described below.

Label	Type	Attribute	Data type
Global label	VAR_GLOBAL	RETAIN	Basic data type, array, structure
Local label of the program block	VAR		
Local label of the Function Block	VAR		
	VAR_INPUT ^{*1}		
	VAR_OUTPUT		
	VAR_PUBLIC		

*1 Only sub-routine type FB can be used.

14.3 Latch Settings

Latch settings

This subsection describes the latch setting.

Setting latch on devices

A range of multiple latches can be set for 1 type of device. Two latch ranges, latch (1) and latch (2), can be set. However, make sure that the range of latch (1) and latch (2) is not overlapping.

■Latch range setting

Set the device to latch, its range, and the latch type.

Operating procedure

"Device Setting" window

Item	Symbol	Device		Latch (1)	Latch (2)
		Points	Range		
Input	X	1024	0 to 1777		
Output	Y	1024	0 to 1777		
Internal Relay	M	7680	0 to 7679	Setting	No Setting
Link Relay	B	256	0 to FF	No Setting	No Setting
Special Link Rela	SB	256	0 to FF		
Annunciator	F	128	0 to 127	No Setting	No Setting
Step Relay	S	4096	0 to 4095	Setting	
Timer	T	512	0 to 511	No Setting	No Setting
Retentive Timer	ST	16	0 to 15	Setting	No Setting
Counter	C	256	0 to 255	Setting	No Setting
Long Counter	LC	64	0 to 63	Setting	No Setting
Data Register	D	8000	0 to 7999	Setting	No Setting
Latch Relay	L	7680	0 to 7679		
Total Device			11.1K Word		9.6K Word
Total Word Device			10.2K Word		8.1K Word
Total Bit Device			15.7K Bit		25.1K Bit

"Latch Range Setting" window

Latch (1)		Latch (2)		
No.	Device	Points (Decimal)	Start	End
1	M	7180	500	7679
2	S	3596	500	4095
3	ST	16	0	15
4	C	100	100	199
5	LC	44	20	63
6	D	7800	200	7999
7				
8				
9				
10				
11				
12				
13				

1. Click "Detailed Setting" on the "Device Setting".
2. On the "Device Setting" window, select the type of latch for the target device. Then, the "Latch Range Setting" window is displayed.
 - Navigation window ⇒ [Parameter] ⇒ [FX5UCPU] ⇒ [CPU Parameter] ⇒ "Memory/Device Setting" ⇒ "Device/Label Memory Area Detailed Setting" ⇒ "Device Setting" ⇒ "Detail Setting"
3. Check the tab for the latch type, select the device to set and set the latch range (Start, End).

Setting latch on labels

This subsection describes latch setting on labels.

Operating procedure

Label edit window

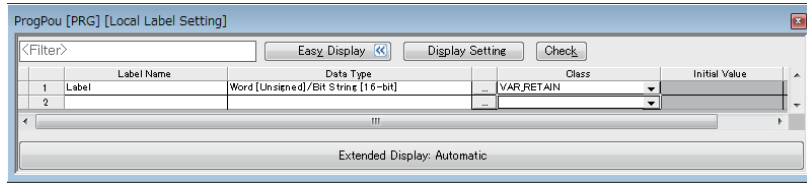

"Device/Label Memory Area Detailed Setting" window

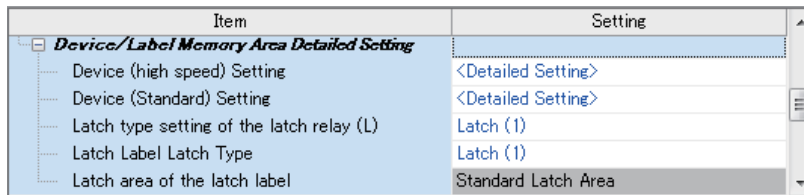

1. In the label edit window, specify "RETAIN" for label attribute.
 2. There are two types of latch for labels: latch (1) and latch (2). Select one. The selected latch type is applied to all labels of with latch attribute.
-  Navigation window ⇒ [Parameter] ⇒ [FX5UCPU] ⇒ [CPU Parameter] ⇒ "Memory/Device Setting" ⇒ "Device/Label Memory Area Detailed Setting" ⇒ "Latch Label Latch Type"

14.4 Clearing of Data of the Latch Range

The data of the latch range can be cleared by the following ways.

Method of latch clearing

By using engineering tools. (GX Works3 Operating Manual)

 [Online]⇒[CPU memory operation]

The range cleared can be selected by performing CPU memory operation.

- Clear the devices outside the latch range.
- Clear the devices outside the latch range and the devices within the range of latch (1).
- Clear the devices outside the latch range, the devices within the range of latch (1) and the devices within the range of latch (2).

Method of clearing by program

■Clearing by program

Execute an RST command to a latched device or clear by sending K0 in MOV/FMOV instructions.

■Clearing by special relay (SM8031 or SM8032)

- SM8031: Clear the devices outside the latch range.
- SM8032: Clear the range of latch (1) and the range of latch (2).

14.5 Precautions

The precaution to be taken when using a latch function is described below.

- When latch range and device no. of points are changed in the parameter, the latching for devices other than link register (W) and latch label will be the same as the latch settings before the change. Also, if the latch range setting parameter at the time of previous operation is different from that at the time of the current operation after the CPU module is powered OFF and ON or reset, the latch data is recovered only in the overlapping part of the latch ranges.
- When latch range and the number of devices are changed in the parameter, all latch labels are cleared to "0".
- When the CPU parameter, program file, FB file, and global label setting file are changed, all latch labels are cleared to "0".
- Special relays and special registers are not cleared even by performing CPU memory operation or special relay clearing.

15 MEMORY CARD FUNCTION

The following explains the functions that use SD memory card.

15.1 SD Memory Card Forced Stop

SD memory card can be disabled without turning power ON→OFF, even when a function that uses SD memory card is being executed.

Methods of SD memory card forced stop

The methods of SD memory card forced stop are as described below.

■Operation by SD memory card disable switch

1. Press the SD memory card disable switch for 1 second or longer.
2. The CARD READY LED will flash on→turn off.*1
3. Remove the SD card.

*1 If there is a function accessing the SD memory card, the CARD READY LED will flash off after the access of that function is complete. Therefore, the time from flash on to flash off will be different depending on the function.

■Operation by special relay

1. Turn ON SM606 (SD memory card forcibly disable command).

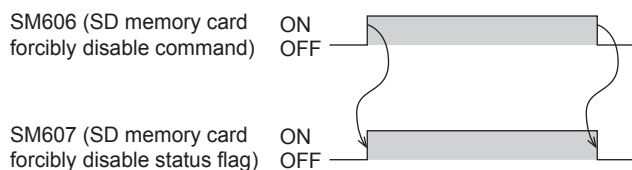

2. Check if CARD READY LED has turned off or SM607 (SD memory card forcibly disable status flag) has turned ON.
3. Remove the SD card.

Operation of function accessing SD memory card

The following table shows the operation when the main function is executed while SD memory card is being accessed and when SD memory card is accessed after SD memory card is disabled.

Function under execution	When main function is executed while SD memory card is being		When SD memory card is accessed after SD memory card is disabled	
	Error check not set*1	Error check set*1	Error check not set*1	Error check set*1
Boot operation • Access to the label/device comment in the SD memory card • Device/label initialization operation at STOP→RUN	After completing execution function, SD memory card turns to disabled status.		—	—
Access to the SD memory card by engineering tool/SLMP function	Error handling occurs.	• Error handling occurs. • CPU module continuation error occurs.	Error handling occurs.	• Error handling occurs. • CPU module continuation error occurs.

*1 Set whether an error due to accessing the SD memory card after SD memory card forced stop will be detected or not.

*2 Operation is same as when the SD memory card is not attached.

Releasing the SD memory card forced stop status

After the SD memory card has turned to disable status, release the SD memory card forced stop status by the operation shown below.

1. Load SD card again.*1
2. Turn OFF→ON the power or reset the CPU module.

*1 The CARD READY LED will blink→light up.

Precautions

The precaution regarding SD memory card forced stop is described below.

- When a forced stop operation is carried out by SD memory card disable switch and forced stop operation by SM606, operation carried out earlier becomes valid, and the operation that is carried out later becomes invalid. For example, after the forced stop by SD memory card disable switch, when SM606 is turned ON→OFF without removing the SD memory card, the disable status of the SD memory card can be released. After the forced stop by SD memory card disable switch, when SD memory card is removed and then SM606 is turned ON, SM606 operation is ignored.

15.2 Boot Operation

At the time of power OFF→ON or reset of the CPU module, a file which is stored on the SD memory card is transferred to the memory of the transfer destination which the CPU module judged automatically.

Boot operation procedure

The selectable files for boot operation are listed below.

1. Carry out the boot file settings.
2. Load SD memory card.
3. Write the boot file settings and boot file to the SD memory card.
4. Turn OFF→ON the power or reset the CPU module.

Specifiable file types

The procedure of boot operation is explained below.

- Parameter files (system parameters, CPU parameters, module parameters, module extension parameters)
- Remote password
- Global labels (global label setting files, initial label values)
- Program files (programs, restored information)
- FB files (FB, restored information)
- Device comments
- Initial device values

Configuring the boot setting

Carry out the settings required for the boot operation.

Navigation window ⇒ [Parameter] ⇒ [FX5UCPU] ⇒ [Memory Card Parameter] ⇒ [Boot Setting]

Operating procedure

"Boot Setting" window

Item	Setting
Boot Setting	
Clear the CPU built-in memory before boot.	Do Not Clear
Boot File Setting	<Detailed Setting>

"Boot File Setting" window

No.	Type	Data Name
1		
2		
3		

"Add Type" window

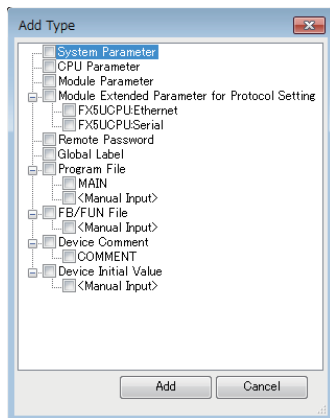

"Boot File Setting" window

No.	Type	Data Name
1	System Parameter	SYSTEM
2	CPU Parameter	CPU
3	Module Parameter	UNIT
4	Module Extended Parameter for Protocol Setting(FX5UCPU-Ethernet)	UEX3FF00
5	Module Extended Parameter for Protocol Setting(FX5UCPU-Serial)	UEX3FF01
6	Remote Password	00000001
7	Global Label	GLBLINF
8	Program File	MAIN
9	Program File	
10	FB/FUN File	
11	Device Comment	COMMENT
12	Device Initial Value	

1. Click "Detailed Setting" on the "Boot File Setting".
2. Click the "Type" column. The maximum number of boot files that can be specified is the same as the number of files that can be stored in the storage memory.
3. Select type for the boot file. (Multiple selection possible)

4. Set the data name (file name).

15

Displayed items

Item	Description	Setting range	Default
Clear the CPU built-in memory before boot	Sets whether or not to clear the CPU built-in memory upon file transfer from the SD memory card.	<ul style="list-style-type: none"> Do Not Clear Clear 	Do Not Clear
Boot File Setting	Sets the files used for boot operation from the SD memory card.	—	—

Maximum number of boot files that can be specified

It is the same as the number of files that can be stored in transfer destination memory.

Operation when security functions are enabled

This section describes the operation when security functions are enabled.

■When a security key is set

When a security key is set to the boot target program file and the security of the program file does not match with that of the CPU module, a boot error occurs. Also, when no security key is written to the CPU module, a boot error occurs as well.

Security key of boot target program file	Security key of CPU module	Security key match/mismatch	Boot program execution
Set	Written	Match	Execute
	Written	Mismatch	Not execute (boot error)
	Not written	—	Not execute (boot error)

■When a file password 32 is set

If a file password 32 is set on both the source boot file and destination file, the file can be transferred only when the passwords match. Furthermore, the file transfer does not work if a file password 32 is set only on either one.

Transferring boot file		Transferred boot file		Password match/mismatch	Transfer
File	File password 32 setting	File	File password 32 setting		
Existing	Set	Existing	Set	Match	Yes
			Mismatch	No	
		Not set	—	No	
	Not set	Existing	Set	—	No
			Not set	Yes	
		Not set	—	Yes	

Precautions

The precautions on the boot operation are explained below.

- The parameter file existing on the module of the transfer destination is overwritten, when a parameter file is set to the boot file. Further, if a parameter file is stored in the SD memory card, but not set to the boot file, the operation will follow the parameter file on the module.
- Note that the model of the program written on the SD memory card (program specified in the boot file settings) and the model of the CPU module must be the same.

16 DEVICE/LABEL ACCESS SERVICE PROCESSING SETTING

This is a function to optionally designate the frequency of execution of the service process that is carried out by the END process in the parameter.

Improvement of communication response with peripheral equipment and extension of scan time by the service process can be controlled by service process setting function. With this, building an optimal service process environment on the system is possible.

About device/label access service processing

Device/label access service processing is a response process for the request statement from peripheral equipment that occurs asynchronously with the scan process. (A process of "Interpretation of Request statement→Internal processing based on the request→Creating response statement" for 1 request statement)

The execution timing of the service process is during the END process.

Point

When every request statement from all connected peripheral equipment is executed in each END process, depending on the number of request statements arriving during 1 scan, the impact on scan time (delay, scattering) may be big. Therefore, by setting the frequency (number of ports) of device/label access service processing to be executed in 1 END processing and regulating the frequency of device/label access service processing according to the system built, ensuring balance between scan time and response time to the peripheral equipment can be achieved.

Compatibility of service process setting

The compatibility of service process setting is described below.

Communication type	Function	Compatibility
Serial communication	MELSOFT connection	○
	MC protocol communication	○
	MODBUS communication (slave)	○
	N:N Network	—
	MODBUS communication (master)	—
	Non-protocol communication	—
	Inverter communication	—
	Predefined protocol support	—
Ethernet communication	MELSOFT connection	○
	SLMP communication	○
	Socket communication	—
	Predefined protocol support	—

○: Compatible, —: Not compatible

Operation details of service process

The operation details of service process are described below.

The following table shows the methods for service process with their respective features.

Device/label access service processing setting	Scan performance		Service process performance		Device splitting ^{*5}	Features
	Extension ^{*1}	Stability ^{*2}	Response time ^{*3}	Stability ^{*4}		
None	Large	Medium	Fast	High	None	Effective when service process is given precedence.
Set the frequency of service process	Medium	High	Medium	Medium	None	Effective when scan process is given precedence.

- *1 Shows the maximum a scan time is extended by the service process.
- *2 Shows the extent of fluctuation of scan time or the degree of scattering by the service process.
- *3 Shows the time between receiving a service process request from the peripheral equipment to returning a response.
- *4 Shows the extent of fluctuation of time until returning the response or the degree of scattering due to the contents of service process request from the peripheral equipment.
- *5 Shows if device splitting will occur.

■Device/label access service processing setting "No Setting"

Since all service processes can be executed normally for every scan time, steady communication is possible even on a system that uses multiple peripheral equipment.



Wait for request process will not be executed when there is no request data.

■Device/label access service processing setting "Set Processing Counts"

Because a frequency of service process executed in 1 scan time can be set, the scan time is stabilized even on a system that uses multiple peripheral equipment.

Operation during STOP/PAUSE

Regardless of the service process settings during STOP/PAUSE, execute all requests in scan 1.

However, a request from the identical port will be processed only 1 time in 1 scan.

For example, after serial communication CH1 process, even if serial communication CH1 receives a new command request again when Ethernet connection 1 is in process, the 2nd request is not executed in this scan and will be carried over to the next scan.

Setting method

The device/label access service processing can be configured as follows.

Navigation window ⇒ [Parameter] ⇒ [FX5UCPU] ⇒ [CPU Parameter] ⇒ "Service Processing Setting" ⇒ "Device/Label Access Service Processing Setting"

Window

Item	Setting
Device/Label Access Service Processing Setting	
Specifying Method	No Setting
Counts	1 Times

Displayed items

Item	Description	Setting range	Default
Specifying Method	Set the method of device/label access service processing.	<ul style="list-style-type: none"> • Set Processing Counts • No Setting 	No Setting
Counts	Set the number of executions of device/label access service processing.	1 to 10 [Time] (1 time Unit)	—

Precautions

If "Set Processing Counts" is selected and many service process frequencies are set, when multiple requests are received at the same time, scan time may be prolonged to a large extent, so please exercise caution.

17.1 Self-Diagnostics Function

Checks if a problem exists with the CPU module.

Self-diagnostics timing

If an error occurs when the CPU module is powered on or while it is in the RUN/STOP state, the CPU module detects, and displays it, and stops operation. However, depending on the error occurrence status or the instruction to execute, the CPU module may not be able to detect the error. Configure safety circuits external to the programmable controller to ensure that the entire system operates safely even in such a case.



Check method of error

This section describes the check methods when error occurs.

Check method using special relay and special register

When the CPU module detects an error, it turns SM0 (Latest Self-diagnostics error (annunciator on included)) and SM1 (Latest Self-diagnostics error (annunciator on not included)) on and stores the error code corresponding to the error definition in SD0 (diagnostics error). If multiple errors are detected, the latest error code is stored in SD0. Use SM0, SM1, and SD0 on the program for the CPU module or mechanical interlock. Besides, the error code up to 16 pieces for the error contents being currently generated will be stored into SD10 (Self-diagnostics error code) to SD25 (Self-diagnostics error code). (The error code for the error content of 17th piece on and after will not be stored.)

Check method using LED

The error occurrence conditions can be checked through the lighting conditions of ERR LED. ( MELSEC iQ-F FX5U User's Manual (Hardware),  MELSEC iQ-F FX5UC User's Manual (Hardware))

Check method using the engineering tool

The error being currently generated can be checked in the Module diagnostics window. ( GX Works3 Operating Manual)

■Existing errors

Up to 16 errors (description of errors) currently existing in the CPU module can be displayed. However, even when an additional error occurs after a stop error, the error information is not refreshed.

Point

The maximum number of displayable errors is 15 for continuation errors and 1 for stop errors. When 15 continuation errors are displayed and another one occurs, description of the new error is not displayed. Also, when an error with the same code has already been displayed, the date and time of occurrence and detailed information of the relevant error are not updated.

CPU Module Operation Upon Error Detection Setting

Configure each CPU Module Operation setting when an error is detected.

Error Detection Setting

Sets whether or not to detect errors.

Navigation window ⇒ [Parameter] ⇒ [FX5UCPU] ⇒ [CPU Parameter] ⇒ "RAS Setting" ⇒ "Error Detections Setting"

Window

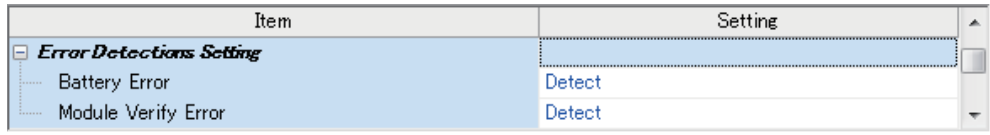

Displayed items

Item	Description	Setting range	Default
Battery Error	Sets whether or not to detect the battery error.	<ul style="list-style-type: none"> • Detect • Not Detected 	Detect
Module Verify Error	Sets whether or not to detect the module verification error.	<ul style="list-style-type: none"> • Detect • Not Detected 	Detect

CPU Module Operation Upon Error Detection Setting

Sets the CPU module operation upon error detection.

Navigation window ⇒ [Parameter] ⇒ [FX5UCPU] ⇒ [CPU Parameter] ⇒ "RAS Setting" ⇒ "CPU Module Operation Setting at Error Detected"

Window

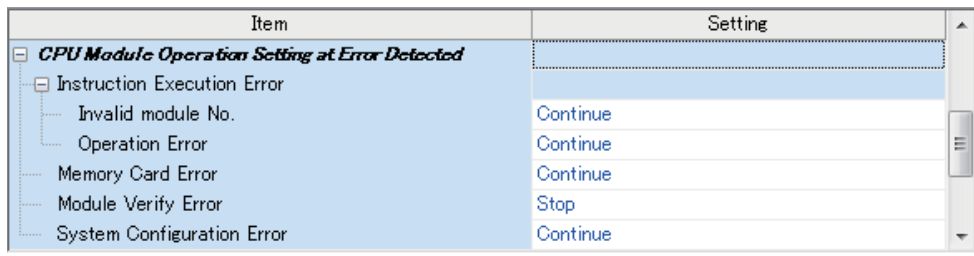

Displayed items

Item	Description	Setting range	Default
Instruction Execution Error	Invalid module No.	<ul style="list-style-type: none"> • Continue • Stop 	Continue
	Operation Error	<ul style="list-style-type: none"> • Continue • Stop 	Continue
Memory Card Error	Sets the CPU module operation upon a memory card error.	<ul style="list-style-type: none"> • Continue • Stop 	Continue
Module Verify Error	Sets the CPU module operation upon a module verification error.	<ul style="list-style-type: none"> • Continue • Stop 	Stop
System Configuration Error	Sets the CPU module operation upon a system configuration error.	<ul style="list-style-type: none"> • Continue • Stop 	Continue

CPU Module Operation Setting

Specify the operation which the CPU module should perform when an error occurs on each intelligent function module.

Navigation window ⇒ [Parameter] ⇒ [System Parameter] ⇒ [I/O Assignment Setting]

Window

Mounting Position	Model Name	Intelligent Module No.	Serial Communication ch	CPU Module Operation Setting at Error Detection
Module				
CPU	FX5U-32MR/ES			
1	FX5-40SSC-S	01 H		Critical: Stop, Moderate: Continue
2				
3				
4				
5				

Displayed items

Item	Description	Setting range	Default
CPU Module Operation Setting at Error Detection	Sets the CPU module operation upon the detection of major or moderate errors in the configured module.	<ul style="list-style-type: none"> Critical: Stop, Moderate: Continue Critical: Stop, Moderate: Stop Critical: Continue, Moderate: Continue 	Critical: Stop, Moderate: Continue

LED display setting

Set whether or not to display the ERROR LED and BATTERY LED.

Navigation window ⇒ [Parameter] ⇒ [FX5UCPU] ⇒ [CPU Parameter] ⇒ "RAS Setting" ⇒ "LED Display Setting"

Window

Item	Setting
LED Display Setting	
ERROR LED	
Minor Error (Continue Error)	Display
BATTERY LED	
Battery Error	Display

Displayed items

Item	Description	Setting range	Default
ERROR LED	Minor Error (Continue Error)	<ul style="list-style-type: none"> Display Do Not Display 	Display
BATTERY LED	Battery Error	<ul style="list-style-type: none"> Display Do Not Display 	Display

Error Clear

This function clears all the existing continuation errors at once.

Errors that can be cleared

Error code	Error name
1080H	ROM write count error
1090H	Battery error
1800H	Annunciator ON
1810H, 1811H	Operation error
1900H	Constant scan time error
1920H	IP address setting error
1921H	IP address writing/clear request simultaneous detection
1FE0 to 1FE6H, 2008H	Module configuration error
2120H, 2121H	Memory card error
2400H	Module verification error
2440H, 2441H	Module major error
2522H	Invalid interrupt
2801H	Module specification error
2820H, 2821H, 2822H, 2823H	Device specification error
2840H	File name specification error
3360H to 3362H	Nesting depth error
3380H	Pointer execution error
3400H to 3406H, 3420H, 3500H, 3502H to 3506H, 350AH, 350C to 350FH, 3510H to 351DH, 3580H, 3581H, 3600H, 3611H to 3614H, 3621H to 3624H, 3631H to 3634H, 3641H to 3644H, 3651H to 3654H, 3661H to 3664H, 3671H to 3674H, 3681H to 3684H, 3691H to 3694H, 36A1H to 36A4H, 36B1H to 36B4H, 36F0H,	Operation error
3780H	High-speed comparison table maximum excess error
3781H	Preset value range outside error

How to clear errors

Errors can be cleared in two ways:

■Using the engineering tool

Clear errors with the module diagnostics function of engineering tool. ( GX Works3 Operating Manual)

■Using SM/SD

Clear errors by operating SM/SD.

1. Check SD0 (Latest self-diagnostics error code) to identify what errors are detected.
2. Clear the cause of each of the currently detected continuation errors.
3. Turn off and on SM50 (error reset).

Precautions

This section describes some precautions to take when using the error clear function:

- Since the function clears all of the currently detected continuation errors at once, errors that should not yet be cleared may be cleared.
- Use the RST instruction to reset each annunciator individually.

18 SECURITY FUNCTIONS

These functions prevent theft, tampering, wrongful operation, illegal execution, etc. of a customer's assets saved on a personal computer or in modules in the FX5 system as a result of illegal access by a third party. Use of the security functions according to the following purposes.

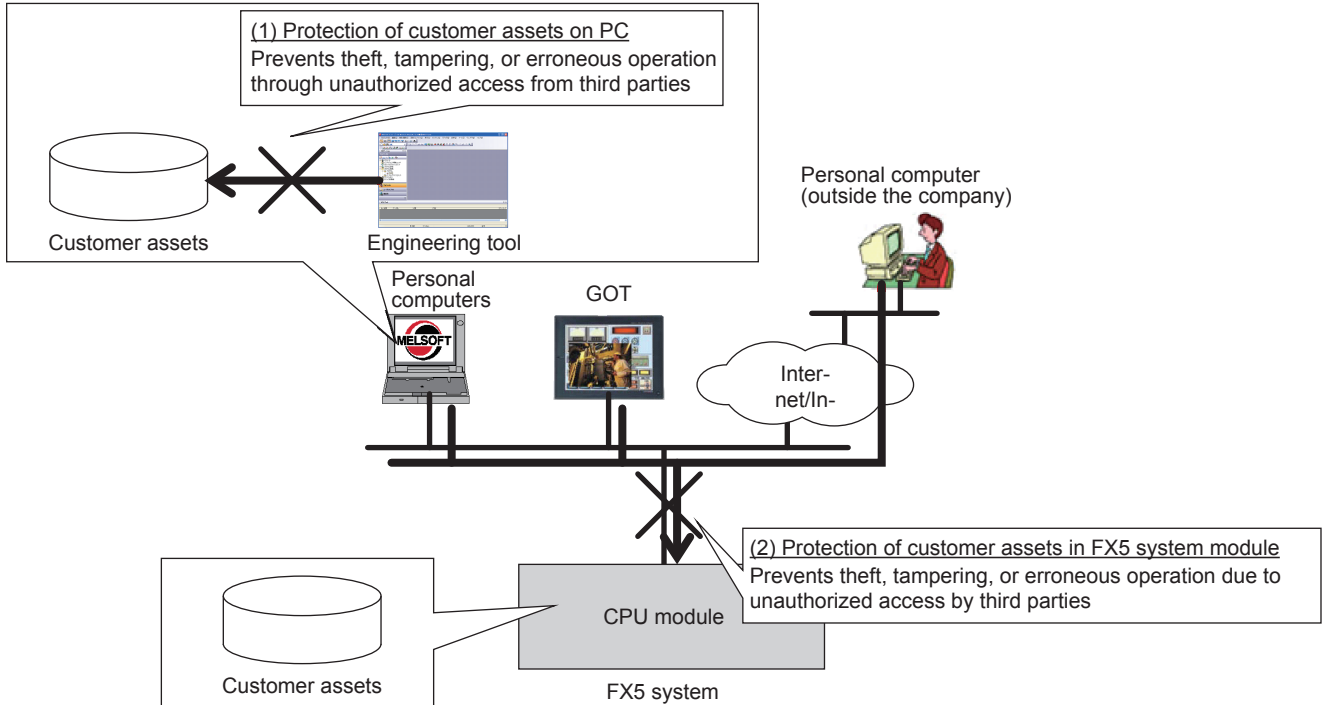

Data protection target	Purpose	Function	Reference
Projects	To prevent illegal accessing and viewing of programs (in program component units). (Password is used.)	Block password function	GX Works3 Operating Manual
	To prevent illegal accessing and viewing of programs (in program file units). (Security key is used.)	Security key authentication function	
CPU Module	To prevent illegal execution of programs. (Security key is used.)		
	To prevent illegal reading/writing of files. (Password is used.)	File password 32 function	
	To limit access from outside a specific communication path. (Password is used.)	Remote password function	GX Works3 Operating Manual MELSEC iQ-F FX5 User's Manual (Ethernet Communication)

Precautions

When a personal computer registered with a security key is misused by a third party, the outflow of program assets cannot be prevented. For this reason, the customer must adopt sufficient measures as explained below:

- Personal computer antitheft measures (using a wire lock, etc.)
- Management of personal computer users (deletion of unwanted accounts, strict control of login information, introduction of fingerprint authentication, etc.)

Also, when a personal computer registered with a security key malfunctions, locked project data cannot be accessed/viewed or edited. Mitsubishi Electric Corporation cannot be held responsible for any loss that may occur as a result of this with the customer, other individuals or organizations. For this reason, the customer must adopt sufficient measures as explained below:

- Export registered security keys and import them into another personal computer.
- Store files containing exported security keys in a safe location.

19 BUILT-IN I/O FUNCTION

The built-in input/output (I/O) function of the CPU module is explained below.
Each respective function is set by parameters in GX Works3.

Function		Reference
High-speed counter function	Normal mode	Page 124
	Pulse density measurement mode	Page 126
	Rotational speed measurement mode	Page 129
FX3-compatible high-speed counter function		Page 165
Pulse width measurement function		Page 174
Pulse catch function	Pulse catch function	Page 184
	FX3-compatible pulse catch function	Page 188
General-purpose input functions		Page 191
PWM function		Page 193
Built-in positioning function		MELSEC iQ-F FX5 User's Manual (Positioning Control)

19.1 High-speed Counter Function

High-speed counter function is explained below.

High-speed counter function overview

The high-speed counter is a function that counts the number of high-speed pulse inputs that cannot be counted by a conventional counter, using the general purpose input terminal of the CPU module.

The high-speed counter assigns input and function settings by parameters and operates using the HIOEN instruction.

Point

Parameter setting and the HIOEN instruction are always required to use the high-speed counter.

High-speed counter parameter setting

High-speed counter channels (input allocation, function) and high-speed counter comparison table, etc., are set by parameters. (☞ Page 123 High-speed counter parameters)

High-speed counter operation mode

The three high-speed counter operation modes are as follows.

Operation mode is set by parameter. (☞ Page 123 High-speed counter parameters)

■ Normal mode

Select normal mode if you want to use as an ordinary high-speed counter. (☞ Page 124 High-speed counter (normal mode))

■ Pulse density measurement mode

Select pulse density measurement mode if you want to count the number of pulses for a specified amount of time. (☞ Page 126 High-speed counter (pulse density measurement mode))

■ Rotational speed measurement mode

Select rotational speed measurement mode if you want to measure speed for a specified amount of time. (☞ Page 129 High-speed counter (rotational speed measurement mode))

High-speed counter dedicated instructions

The high-speed counter starts and stops counting using the HIOEN instruction for the high-speed counter. (☞ MELSEC iQ-F FX5 Programming Manual (Instructions, Standard Functions/Function Blocks))

Other high-speed counter instructions

In addition to the dedicated instructions, there are instructions such as DHSCS, DHSCR, and DHSZ (hereafter referred to as "high-speed comparison instruction") for high-speed counters.

For details, refer to the following.

📖 MELSEC iQ-F FX5 Programming Manual (Instructions, Standard Functions/Function Blocks)

High-speed counter function execution procedure

The high-speed counter function execution procedure is as follows.

1. Check the specifications of the high-speed counter.

Check specifications such as maximum frequency and type of high-speed counter. (📖 Page 115 High-speed counter specifications)

2. Connect the CPU module to the external device.

For details on wiring to external devices, refer to the following manual

📖 MELSEC iQ-F FX5U User's Manual (Hardware)

📖 MELSEC iQ-F FX5UC User's Manual (Hardware)

3. Set the parameters.

Set parameters such as channel (CH) of the high-speed counter. (📖 Page 123 High-speed counter parameters)

4. Create the program.

Create program for using the high-speed counter.

5. Run the program.

High-speed counter specifications

High-speed counter specifications are explained below.

Types of high-speed counters

Types of high-speed counters are as follows.

■ 1 phase, 1 input counter (S/W)

Counting method of 1 phase, 1 input counter (S/W) is as follows.

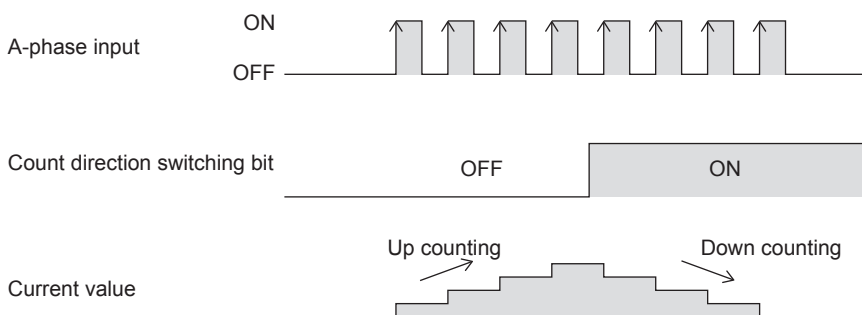

■ 1 phase, 1 input counter (H/W)

Counting method of 1 phase, 1 input counter (H/W) is as follows.

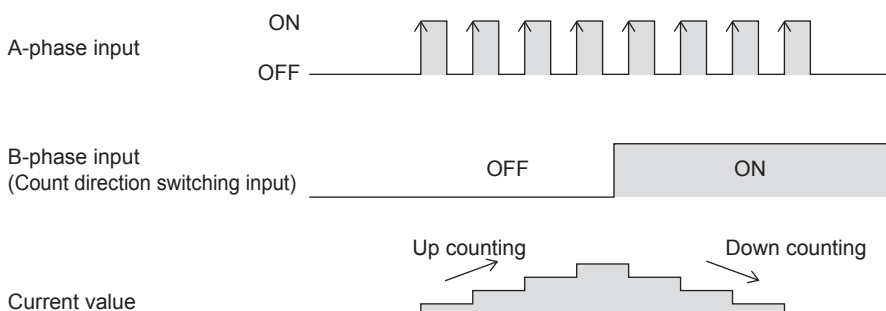

■1 phase, 2 input counter

Counting method of 1 phase, 2 input counter is as follows.

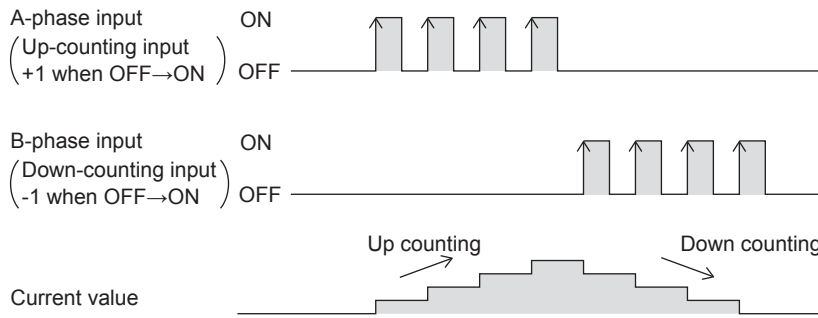

■2 phase, 2 input counter [1 edge count]

Counting method of 2 phase, 2 input counter [1 edge count] is as follows.

Up/down counter	Counter timing
At up-counting	1 count up when phase A input is ON and phase B input switches OFF→ON
At down-counting	1 count down when phase A input is ON and phase B input switches ON→OFF

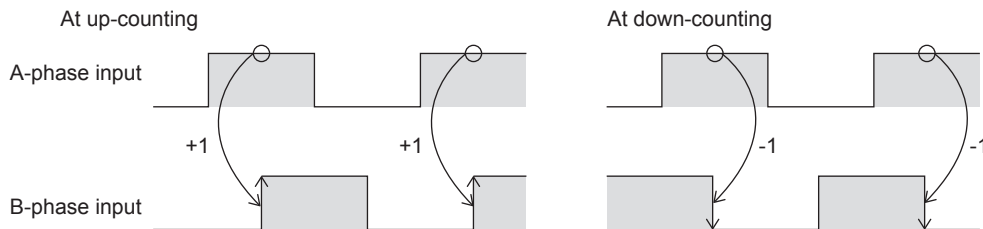

■2 phase, 2 input counter [2 edge count]

Counting method of 2 phase, 2 input counter [2 edge count] is as follows.

Up/down counter	Counter timing
At up-counting	1 count up when phase A input is ON and phase B input switches OFF→ON 1 count up when phase A input is OFF and phase B input switches ON→OFF
At down-counting	1 count down when phase A input is ON and phase B input switches ON→OFF 1 count down when phase A input is OFF and phase B input switches OFF→ON

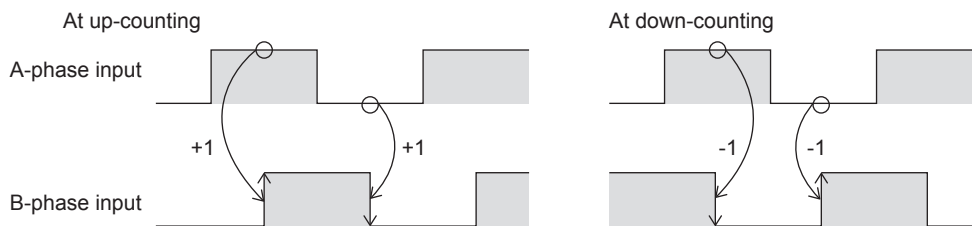

■2 phase, 2 input counter [4 edge count]

Counting method of 2 phase, 2 input counter [4 edge count] is as follows.

Up/down counter	Counter timing
At up-counting	1 count up when phase B input is OFF and phase A input switches OFF→ON 1 count up when phase A input is ON and phase B input switches OFF→ON 1 count up when phase B input is ON and phase A input switches ON→OFF 1 count up when phase A input is OFF and phase B input switches ON→OFF
At down-counting	1 count down when phase A input is OFF and phase B input switches OFF→ON 1 count down when phase B input is ON and phase A input switches OFF→ON 1 count down when phase A input is ON and phase B input switches ON→OFF 1 count down when phase B input is OFF and phase A input switches ON→OFF

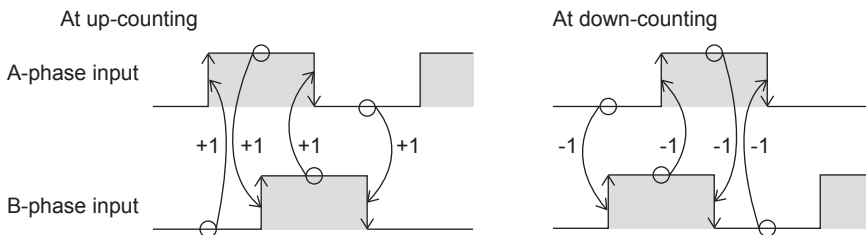

■Internal clock

Counting method of internal clock is as follows.

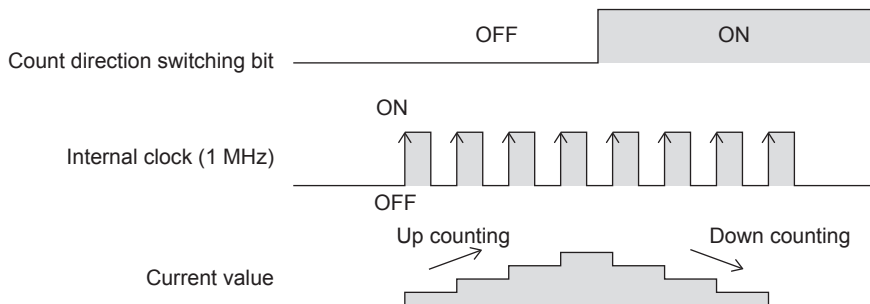

Point

Under ordinary circumstances, the internal clock counts up/down by 1 MHz clock. External input is not used.

Maximum frequency

The maximum frequency that each type of counter can count is as follows.

For details concerning maximum frequency by input assignment, refer to [Page 120 Input assignment-wise / maximum frequency for high-speed counters.](#)

Counter type	Maximum frequency
1 phase, 1 input counter (S/W)	200 KHz
1 phase, 1 input counter (H/W)	200 KHz
1 phase, 2 input counter	200 KHz
2 phase, 2 input counter [1 edge count]	200 KHz
2 phase, 2 input counter [2 edge count]	100 KHz
2 phase, 2 input counter [4 edge count]	50 KHz
Internal clock	1 MHz (fixed)

Precautions

- The input circuit of the CPU module has restrictions for maximum frequency

FX5U-32M□, FX5UC-32M□	FX5U-64M□, FX5U-80M□	Maximum frequency
X0 to X5	X0 to X7	200 KHz
X6 to X17	X10 to X17	10 KHz

- If input response time is set, maximum frequency is affected by the setting value.
- Under ordinary circumstances, the internal clock counts at 1 MHz (fixed) during operation.

Matched output performance

If output is to Y0 to Y17 using high-speed comparison instructions (DHSCS, DHSCR, DHSZ instruction), high-speed comparison table, or multiple point output high-speed comparison table, time from pulse input→comparison of count value (match)→output to Y is 5 μs + input response time.

If output is to Y20 or subsequent, time from pulse input to output is affected by communication and user interrupt.

Count range

-2147483648 to +2147483647. These are signed 32-bit ring counters.

Ring length setting is however in the range of 0 to 2147483647.

Assignment for high-speed counters

Input assignment for high-speed counters

Assignment for input devices of high-speed counters is set by parameters.

Assignment is determined according to functions set for each channels by parameter.

When using internal clock, assignment is same as 1-phase, 1-count (S/W) and phase A is not used.

Input assignment of high-speed counters is as follows.

CH	High-speed counter type	X0	X1	X2	X3	X4	X5	X6	X7	X10	X11	X12	X13	X14	X15	X16	X17
CH1	1-phase 1-count (S/W)	A								P	E						
	1-phase 1-count (H/W)	A	B							P	E						
	1-phase 2-count	A	B							P	E						
	2-phase 2-count	A	B							P	E						
CH2	1-phase 1-count (S/W)		A									P	E				
	1-phase 1-count (H/W)			A	B							P	E				
	1-phase 2-count			A	B							P	E				
	2-phase 2-count			A	B							P	E				
CH3	1-phase 1-count (S/W)			A										P	E		
	1-phase 1-count (H/W)					A	B							P	E		
	1-phase 2-count					A	B							P	E		
	2-phase 2-count					A	B							P	E		
CH4	1-phase 1-count (S/W)				A											P	E
	1-phase 1-count (H/W)							A	B							P	E
	1-phase 2-count							A	B							P	E
	2-phase 2-count							A	B							P	E
CH5	1-phase 1-count (S/W)					A				P	E						
	1-phase 1-count (H/W)									A	B	P	E				
	1-phase 2-count									A	B	P	E				
	2-phase 2-count									A	B	P	E				
CH6	1-phase 1-count (S/W)						A					P	E				
	1-phase 1-count (H/W)											A	B	P	E		
	1-phase 2-count											A	B	P	E		
	2-phase 2-count											A	B	P	E		
CH7	1-phase 1-count (S/W)							A						P	E		
	1-phase 1-count (H/W)													A	B	P	E
	1-phase 2-count													A	B	P	E
	2-phase 2-count													A	B	P	E
CH8	1-phase 1-count (S/W)								A							P	E
	1-phase 1-count (H/W)														A	B	
	1-phase 2-count														A	B	
	2-phase 2-count														A	B	
CH1 to CH8	Internal clock	Not used															

A: A phase input

B: Phase B input (direction switch input is however employed in the case of 1-phase 1-count [H/W])

P: External preset input

E: External enable input

Input assignment-wise / maximum frequency for high-speed counters

Input assignment-wise maximum frequency for high-speed counters is as follows.

■FX5U-32M□, FX5UC-32M□



- X6 to X17 are input frequencies up to 10 KHz, regardless of maximum frequency value.
- Preset input and Enable Input are input frequencies up to 10 KHz, regardless of maximum frequency value.

CH	High-speed counter type	X0	X1	X2	X3	X4	X5	X6	X7	X10	X11	X12	X13	X14	X15	X16	X17	Maximum frequency
CH1	1-phase 1-count (S/W)	A								P	E							200 KHz
	1-phase 1-count (H/W)	A	B							P	E							200 KHz
	1-phase 2-count	A	B							P	E							200 KHz
	2-phase 2-count [1 edge count]	A	B							P	E							200 KHz
	2-phase 2-count [2 edge count]	A	B							P	E							100KHz
	2-phase 2-count [4 edge count]	A	B							P	E							50 KHz
CH2	1-phase 1-count (S/W)		A									P	E					200 KHz
	1-phase 1-count (H/W)			A	B							P	E					200 KHz
	1-phase 2-count			A	B							P	E					200 KHz
	2-phase 2-count [1 edge count]			A	B							P	E					200 KHz
	2-phase 2-count [2 edge count]			A	B							P	E					100 KHz
	2-phase 2-count [4 edge count]			A	B							P	E					50 KHz
CH3	1-phase 1-count (S/W)			A										P	E			200 KHz
	1-phase 1-count (H/W)				A	B								P	E			200 KHz
	1-phase 2-count				A	B								P	E			200 KHz
	2-phase 2-count [1 edge count]				A	B								P	E			200 KHz
	2-phase 2-count [2 edge count]					A	B							P	E			100 KHz
	2-phase 2-count [4 edge count]					A	B							P	E			50 KHz
CH4	1-phase 1-count (S/W)				A											P	E	200 KHz
	1-phase 1-count (H/W)							A	B							P	E	10 KHz
	1-phase 2-count							A	B							P	E	10 KHz
	2-phase 2-count [1 edge count]							A	B							P	E	10 KHz
	2-phase 2-count [2 edge count]								A	B						P	E	5 KHz
	2-phase 2-count [4 edge count]									A	B					P	E	2.5 KHz
CH5	1-phase 1-count (S/W)					A				P	E							200 KHz
	1-phase 1-count (H/W)									A	B	P	E					10 KHz
	1-phase 2-count									A	B	P	E					10 KHz
	2-phase 2-count [1 edge count]									A	B	P	E					10 KHz
	2-phase 2-count [2 edge count]										A	B	P	E				5 KHz
	2-phase 2-count [4 edge count]											A	B	P	E			2.5 KHz

CH	High-speed counter type	X0	X1	X2	X3	X4	X5	X6	X7	X10	X11	X12	X13	X14	X15	X16	X17	Maximum frequency
CH6	1-phase 1-count (S/W)						A					P	E					200 KHz
	1-phase 1-count (H/W)											A	B	P	E			10 KHz
	1-phase 2-count											A	B	P	E			10 KHz
	2-phase 2-count [1 edge count]											A	B	P	E			10 KHz
	2-phase 2-count [2 edge count]											A	B	P	E			5 KHz
	2-phase 2-count [4 edge count]											A	B	P	E			2.5 KHz
CH7	1-phase 1-count (S/W)							A						P	E			10 KHz
	1-phase 1-count (H/W)													A	B	P	E	10 KHz
	1-phase 2-count													A	B	P	E	10 KHz
	2-phase 2-count [1 edge count]													A	B	P	E	10 KHz
	2-phase 2-count [2 edge count]													A	B	P	E	5 KHz
	2-phase 2-count [4 edge count]													A	B	P	E	2.5KHz
CH8	1-phase 1-count (S/W)								A							P	E	10 KHz
	1-phase 1-count (H/W)															A	B	10 KHz
	1-phase 2-count															A	B	10 KHz
	2-phase 2-count [1 edge count]															A	B	10 KHz
	2-phase 2-count [2 edge count]															A	B	5KHz
	2-phase 2-count [4 edge count]															A	B	2.5KHz

A: A phase input, B: B phase input, P: External preset input, E: External enable input

■FX5U-64M□, FX5U-80M□



- X10 to X17 are input frequencies up to 10 KHz, regardless of maximum frequency value.
- Preset input and Enable Input are input frequencies up to 10 KHz, regardless of maximum frequency value.

CH	High-speed counter type	X0	X1	X2	X3	X4	X5	X6	X7	X10	X11	X12	X13	X14	X15	X16	X17	Maximum frequency
CH1	1-phase 1-count (S/W)	A								P	E							200 KHz
	1-phase 1-count (H/W)	A	B							P	E							200 KHz
	1-phase 2-count	A	B							P	E							200 KHz
	2-phase 2-count [1 edge count]	A	B							P	E							200 KHz
	2-phase 2-count [2 edge count]	A	B							P	E							100KHz
	2-phase 2-count [4 edge count]	A	B							P	E							50 KHz
CH2	1-phase 1-count (S/W)		A									P	E					200 KHz
	1-phase 1-count (H/W)			A	B							P	E					200 KHz
	1-phase 2-count			A	B							P	E					200 KHz
	2-phase 2-count [1 edge count]			A	B							P	E					200 KHz
	2-phase 2-count [2 edge count]			A	B							P	E					100 KHz
	2-phase 2-count [4 edge count]			A	B							P	E					50 KHz

CH	High-speed counter type	X0	X1	X2	X3	X4	X5	X6	X7	X10	X11	X12	X13	X14	X15	X16	X17	Maximum frequency
CH3	1-phase 1-count (S/W)			A										P	E			200 KHz
	1-phase 1-count (H/W)					A	B							P	E			200 KHz
	1-phase 2-count					A	B							P	E			200 KHz
	2-phase 2-count [1 edge count]					A	B							P	E			200 KHz
	2-phase 2-count [2 edge count]					A	B							P	E			100 KHz
	2-phase 2-count [4 edge count]					A	B							P	E			50 KHz
CH4	1-phase 1-count (S/W)				A											P	E	200 KHz
	1-phase 1-count (H/W)							A	B							P	E	200 KHz
	1-phase 2-count							A	B							P	E	200 KHz
	2-phase 2-count [1 edge count]							A	B							P	E	200 KHz
	2-phase 2-count [2 edge count]							A	B							P	E	100KHz
	2-phase 2-count [4 edge count]							A	B							P	E	50 KHz
CH5	1-phase 1-count (S/W)					A				P	E							200 KHz
	1-phase 1-count (H/W)									A	B	P	E					10 KHz
	1-phase 2-count									A	B	P	E					10 KHz
	2-phase 2-count [1 edge count]									A	B	P	E					10 KHz
	2-phase 2-count [2 edge count]									A	B	P	E					5 KHz
	2-phase 2-count [4 edge count]									A	B	P	E					2.5 KHz
CH6	1-phase 1-count (S/W)						A					P	E					200 KHz
	1-phase 1-count (H/W)											A	B	P	E			10 KHz
	1-phase 2-count											A	B	P	E			10 KHz
	2-phase 2-count [1 edge count]											A	B	P	E			10 KHz
	2-phase 2-count [2 edge count]											A	B	P	E			5 KHz
	2-phase 2-count [4 edge count]											A	B	P	E			2.5 KHz
CH7	1-phase 1-count (S/W)							A						P	E			200 KHz
	1-phase 1-count (H/W)													A	B	P	E	10 KHz
	1-phase 2-count													A	B	P	E	10 KHz
	2-phase 2-count [1 edge count]													A	B	P	E	10 KHz
	2-phase 2-count [2 edge count]													A	B	P	E	5 KHz
	2-phase 2-count [4 edge count]													A	B	P	E	2.5KHz
CH8	1-phase 1-count (S/W)								A							P	E	200 KHz
	1-phase 1-count (H/W)															A	B	10 KHz
	1-phase 2-count															A	B	10 KHz
	2-phase 2-count [1 edge count]															A	B	10 KHz
	2-phase 2-count [2 edge count]															A	B	5KHz
	2-phase 2-count [4 edge count]															A	B	2.5KHz

A: A phase input, B: B phase input, P: External preset input, E: External enable input

High-speed counter parameters

High-speed counter parameters are explained below.

High-speed counter parameters are set by GX Works3.

Outline of parameters

High-speed counter settings, high-speed comparison table, multiple point high-speed comparison table setting and input response time are set by parameters.

The primary items that can be set by parameters are as follows.

- Basic settings
- High-speed comparison table setting
- Multiple point output high-speed table setting
- Input response time setting

Parameter setting

High-speed counter parameter setting method is explained below.

For parameter setting of each operation, refer to the following.

- For high-speed counters (normal mode), refer to [☞ Page 124 High-speed counter \(normal mode\)](#).
- For high-speed counter (pulse density measurement mode), refer to [☞ Page 126 High-speed counter \(pulse density measurement mode\)](#).
- For high-speed counter (rotational speed measurement mode), refer to [☞ Page 129 High-speed counter \(rotational speed measurement mode\)](#).
- For high-speed comparison table, refer to [☞ Page 132 High-speed comparison table](#).
- For multiple point output, high-speed comparison tables, refer to [☞ Page 134 Multiple point output, high-speed comparison tables](#).
- For input response time, refer to [☞ Page 191 General-purpose Input Functions](#).

Point

Parameters are enabled when the CPU module is powered ON or after a reset. In addition, operations different from the parameter settings are possible by transferring values to special relays and special registers while changing these values in the program.

For details concerning special relays and special registers for high-speed counters, refer to [☞ Page 137 Special relay list](#), [☞ Page 148 Special registers list](#).

High-speed counter (normal mode)

Normal mode for high-speed counters is explained below.

Use normal mode if you want to use as an ordinary high-speed counter.

Set operation mode to normal mode by high-speed counter parameter setting.

Sets detailed settings for channel used.

Navigation window ⇒ [Parameter] ⇒ [FX5UCPU] ⇒ [Module Parameter] ⇒ [High Speed I/O] ⇒ "Input Function" ⇒ "High Speed Counter" ⇒ "Detail Setting" ⇒ "Basic Settings"

Window

Item	CH1	CH2
Use/Do Not Use Counter	Set whether use counter or not.	
Use/Not Use	Enable	Disable
Operation Mode	Set operation mode.	
Operation Mode	Normal Mode	Normal Mode
Pulse Input Mode	Set pulse input mode.	
Pulse Input Mode	1-Phase 1 Input (S/W Up/Down Switch)	1-Phase 1 Input (S/W Up/Down Switch)
Preset Input	Set present.	
Preset Input Enable/Disable	Disable	Disable
Input logic	Positive Logic	Positive Logic
Preset Value	0	0
Input Comparison Enable/Disable	Disable	Disable
Control Switch	Rising	Rising
Enable Input	Set enable input.	
Enable Input Enable/Disable	Disable	Disable
Input logic	Positive Logic	Positive Logic
Ring Length Setting	Set ring length setting.	
Ring Length Enable/Disable	Disable	Disable
Ring Length		
Measurement Unit Time	Set measurement unit time.	
Measurement Unit Time		
Pulse No. of per Rotation	Set the pulse No. of per rotation.	
Pulse No. of per Rotation	1000	1000



Displayed items

Item	Description	Setting range	Default
Use/Not Use	Set whether use counter or not.	<ul style="list-style-type: none"> Disable Enable 	Disable
Operation Mode	Set operation mode.	<ul style="list-style-type: none"> Normal Mode Pulse Density Assumption Mode Rotation Speed Measurement Mode 	—
Pulse Input Mode	Set pulse input mode.	<ul style="list-style-type: none"> 1-Phase 1 Input (S/W Up/Down Switch) 1-Phase 1 Input (H/W Up/Down Switch) 1 Phase 2 Input 2 Phase 1 Multiple 2 Phase 2 Multiple 2 Phase 4 Multiple Internal Clock (1MHz) 	—
Preset Input Enable/Disable	Set whether to "enable" or "disable" the preset input of counter.	<ul style="list-style-type: none"> Disable Enable 	—
Input Logic	Sets preset input logic when preset input is enabled.	<ul style="list-style-type: none"> Positive Logic Negative Logic 	—

Item	Description	Setting range	Default
Preset Value	Sets preset value when preset input is enabled.	-2147483648 to +2147483647	—
Input Comparison Enable/Disable	Sets whether to "enable" or "disable" input comparison when preset input is enabled.	<ul style="list-style-type: none"> • Disable • Enable 	—
Control Switch	Sets preset execution timing when preset input is enabled.	<ul style="list-style-type: none"> • Rising • Falling • Rising + Falling Edge • Always During Input ON 	—
Enable Input Enable/Disable	Set whether to "enable" or "disable" the enable input.	<ul style="list-style-type: none"> • Disable • Enable 	—
Input Logic	Set the enable input logic value.	<ul style="list-style-type: none"> • Positive Logic • Negative Logic 	—
Ring Length Enable/Disable	Sets whether to "enable" or "disable" the ring length for ring counters.	<ul style="list-style-type: none"> • Disable • Enable 	—
Ring Length	Sets ring length when ring length setting is enabled.	2 to 2147483648	—
Measurement Unit Time	Not available for high-speed counters (normal mode).	—	—
Pulses No. of per Rotation			

Point

Parameters are enabled when the CPU module is powered ON or after a reset. In addition, operations different from the parameter settings are possible by transferring values to special relays and special registers while changing these values in the program.

For details concerning special relays and special registers for high-speed counters, refer to  Page 137 Special relay list,  Page 148 Special registers list.

Starting/stopping high-speed counter measurement

High-speed counters cannot count by setting the parameter alone.

The HIOEN instruction is required to start/stop the count.

For the HIOEN instruction, refer to  MELSEC iQ-F FX5 Programming Manual (Instructions, Standard Functions/Function Blocks).

Read/write of current value of high-speed counter

The current value of the high-speed counter is stored in a special register for each channel. You can check current value by monitoring the value. The value may however differ from the actual value because the special register is updated during END processing.

You can read the latest value using the HCMOV instruction.

For details concerning special registers for high-speed counters, refer to  Page 148 Special registers list.

For information for the HCMOV instruction, refer to  MELSEC iQ-F FX5 Programming Manual (Instructions, Standard Functions/Function Blocks).

Precautions

- Input used varies according to channel selected and pulse input mode.
- If not using preset input or enable input, you can use it as input for other functions.
- If mode is other than normal mode, preset input cannot be used.
- Use the HIOEN instruction to start high-speed counter measurement.
- There are common precautions when using high-speed counters. For details, refer to  Page 163 Precautions when using high-speed counters.

High-speed counter (pulse density measurement mode)

The pulse density measurement mode for high-speed counters is explained below.

When in pulse density measurement mode, pulse is counted from count input of the high-speed counter, and the number of pulses for a specified amount of time is automatically counted.

Set operation mode to pulse density measurement mode by high-speed counter parameter setting.

Sets detailed settings for channel used.

Navigation window ⇒ [Parameter] ⇒ [FX5UCPU] ⇒ [Module Parameter] ⇒ [High Speed I/O] ⇒ "Input Function" ⇒ "High Speed counter" ⇒ "Detail Setting" ⇒ "Basic Settings"

Window

Item	CH1	CH2
Use/Do Not Use Counter	Set whether use counter or not.	
Use/Not Use	Enable	Disable
Operation Mode	Set operation mode.	
<i>Operation Mode</i>	Pulse Density Assumption Mode	Normal Mode
Pulse Input Mode	Set pulse input mode.	
Pulse Input Mode	1-Phase 1 Input (S/W Up/Down Switch)	1-Phase 1 Input (S/W Up/Down Switch)
Preset Input	Set present.	
Preset Input Enable/Disable	Disable	Disable
Input logic	Positive Logic	Positive Logic
Preset Value	0	0
Input Comparison Enable/Disable	Disable	Disable
Control Switch	Rising	Rising
Enable Input	Set enable input.	
Enable Input Enable/Disable	Disable	Disable
Input logic	Positive Logic	Positive Logic
Ring Length Setting	Set ring length setting.	
Ring Length Enable/Disable	Disable	Disable
Ring Length		
Measurement Unit Time	Set measurement unit time.	
Measurement Unit Time	1000	
Pulse No. of per Rotation	Set the pulse No. of per rotation.	
Pulse No. of per Rotation	1000	1000



Displayed items

Item	Description	Setting range	Default
Use/Not Use	Set whether use counter or not.	<ul style="list-style-type: none"> Disable Enable 	Disable
Operation Mode	Set operation mode.	<ul style="list-style-type: none"> Normal Mode Pulse Density Assumption Mode Rotation Speed Measurement Mode 	—
Pulse Input Mode	Set pulse input mode.	<ul style="list-style-type: none"> 1-Phase 1 Input (S/W Up/Down Switch) 1-Phase 1 Input (H/W Up/Down Switch) 1 Phase 2 Input 2 Phase 1 Multiple 2 Phase 2 Multiple 2 Phase 4 Multiple Internal Clock (1MHz) 	—

Item	Description	Setting range	Default
Preset Input Enable/ Disable	Not available for high-speed counters (pulse density measurement mode).	—	—
Input Logic			
Preset Value			
Input Comparison Enable/ Disable			
Control Switch			
Enable Input Enable/ Disable	Set whether to "enable" or "disable" the enable input.	<ul style="list-style-type: none"> • Disable • Enable 	—
Input Logic	Set the enable input logic value.	<ul style="list-style-type: none"> • Positive Logic • Negative Logic 	—
Ring Length Enable/ Disable	Not available for high-speed counters (pulse density measurement mode).	—	—
Ring Length			
Measurement Unit Time	Set measurement unit time. (Unit: ms)	1 to 2147483647	—
Pulses No. of per Rotation	Not available for high-speed counters (pulse density measurement mode).	—	—

Point

Parameters are enabled when the CPU module is powered ON or after a reset. In addition, operations different from the parameter settings are possible by transferring values to special relays and special registers while changing these values in the program.

For details concerning special relays and special registers for high-speed counters, refer to  Page 137 Special relay list,  Page 148 Special registers list.

Pulse density measurement mode start/stop

The pulse density measurement mode cannot measure by setting the parameter alone.

The HIOEN instruction is required to start/stop measurement.

For the HIOEN instruction, refer to  MELSEC iQ-F FX5 Programming Manual (Instructions, Standard Functions/Function Blocks).

Pulse density

Pulse density is stored in the special register for each channel.

For details concerning special registers for high-speed counters, refer to  Page 148 Special registers list.

Precautions

■Count direction switch during measurement

The pulse density measurement mode calculates pulse density based on difference in measuring unit time of the current value of high-speed counters. You should therefore note that the input number of pulses may differ from the measurement value when count direction of a high-speed counter is switched within the same measuring unit time.

Ex.

When pulse density is measured, 14 pulses are input within measuring unit time, but the current value of the high-speed counter remains "0", as shown in the following figure. As a result, pulse density is "0" for this measuring unit time.

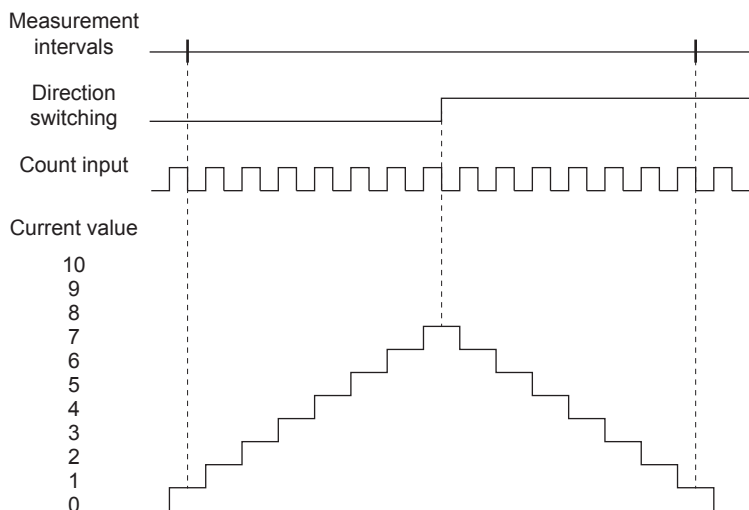

■Operation when counting in the minus direction

Pulse density can also be measured when pulses are input in the direction whereby current value of high-speed counter is reduced.

■Operation at overflow of high-speed counter current value

Pulse density measurement can continue even when current value of high-speed counter overflows during measurement.

■Relationship with the SPD instruction

Measurement time specified by operand of the SPD instruction is overwritten in the special register for measuring unit time used by the pulse density measurement function. Measurement results of the SPD instruction are also stored in the special register of measurement results.

If pulse density measurement has already been started by the HIOEN instruction, the SPD instruction cannot be used for the same channel.

Inversely, if pulse density is currently being measured by the SPD instruction, pulse density measurement cannot be started for the same channel.

■Other precautions

There are common precautions when using high-speed counters. For details, refer to [Page 163 Precautions when using high-speed counters](#).

High-speed counter (rotational speed measurement mode)

The rotational speed measurement mode for high-speed counters is explained below.

When in rotational speed measurement mode, pulse is counted from count input of the high-speed counter, and the rotational speed for a specified amount of time is automatically calculated.

Set operation mode to rotational speed measurement mode by high-speed counter parameter setting.

Sets detailed settings for channel used.

Navigation window ⇒ [Parameter] ⇒ [FX5UCPU] ⇒ [Module Parameter] ⇒ [High Speed I/O] ⇒ "Input Function" ⇒ "High Speed Counter" ⇒ "Detail Setting" ⇒ "Basic Setting"

Window

Item	CH1	CH2
Use/Do Not Use Counter	Set whether use counter or not.	
Use/Not Use	Enable	Disable
Operation Mode	Set operation mode.	
<i>Operation Mode</i>	Rotation Speed Measurement Mode	Normal Mode
Pulse Input Mode	Set pulse input mode.	
Pulse Input Mode	1-Phase 1 Input (S/W Up/Down Switch)	1-Phase 1 Input (S/W Up/Down Switch)
Preset Input	Set present.	
Preset Input Enable/Disable	Disable	Disable
Input logic	Positive Logic	Positive Logic
Preset Value	0	0
Input Comparison Enable/Disable	Disable	Disable
Control Switch	Rising	Rising
Enable Input	Set enable input.	
Enable Input Enable/Disable	Disable	Disable
Input logic	Positive Logic	Positive Logic
Ring Length Setting	Set ring length setting.	
Ring Length Enable/Disable	Disable	Disable
Ring Length		
Measurement Unit Time	Set measurement unit time.	
Measurement Unit Time	1000	
Pulse No. of per Rotation	Set the pulse No. of per rotation.	
Pulse No. of per Rotation	1000	1000



Displayed items

Item	Description	Setting range	Default
Use/Not Use	Set whether use counter or not.	<ul style="list-style-type: none"> • Disable • Enable 	Disable
Operation Mode	Set operation mode.	<ul style="list-style-type: none"> • Normal Mode • Pulse Density Assumption Mode • Rotation Speed Measurement Mode 	—
Pulse Input Mode	Set pulse input mode.	<ul style="list-style-type: none"> • 1-Phase 1 Input (S/W Up/Down Switch) • 1-Phase 1 Input (H/W Up/Down Switch) • 1 Phase 2 Input • 2 Phase 1 Multiple • 2 Phase 2 Multiple • 2 Phase 4 Multiple • Internal Clock (1MHz) 	—

Item	Description	Setting range	Default
Preset Input Enable/ Disable	Not available for high-speed counters (rotational speed measurement mode).	—	—
Input Logic			
Preset Value			
Input Comparison Enable/ Disable			
Control Switch			
Enable Input Enable/ Disable	Set whether to "enable" or "disable" the enable input.	<ul style="list-style-type: none"> • Disable • Enable 	—
Input Logic	Set the enable input logic value.	<ul style="list-style-type: none"> • Positive Logic • Negative Logic 	—
Ring Length Enable/ Disable	Not available for high-speed counters (rotational speed measurement mode).	—	—
Ring Length			
Measurement Unit Time	Set measurement unit time. (Unit: ms)	1 to 2147483647	—
Pulses No. of per Rotation	Set the No. of pulses per rotation. (Unit: ms)	1 to 2147483647	—

Point

Parameters are enabled when the CPU module is powered ON or after a reset. In addition, operations different from the parameter settings are possible by transferring values to special relays and special registers while changing these values in the program.

For details concerning special relays and special registers for high-speed counters, refer to  Page 137 Special relay list,  Page 148 Special registers list.

Rotational speed measurement mode start/stop

The rotational speed measurement mode cannot measure by setting the parameter alone.

The HIOEN instruction is required to start/stop measurement.

For the HIOEN instruction, refer to  MELSEC iQ-F FX5 Programming Manual (Instructions, Standard Functions/Function Blocks).

Rotational speed

Rotational speed is stored in the special register for each channel.

For details concerning special registers for high-speed counters, refer to  Page 148 Special registers list.

Precautions

■Count direction switch during measurement

The rotational speed measurement mode calculates rotational speed based on current value difference of high-speed counters in the measuring unit time. You should therefore note that the input number of pulses may differ from the measurement value when count direction of a high-speed counter is switched within the same measuring unit time.

■Operation when counting in the minus direction

Rotational speed can also be measured when pulses are input in the direction whereby current value of high-speed counter is reduced.

■Operation at overflow of high-speed counter current value

Rotational speed measurement can continue even when current value of high-speed counter overflows during measurement.

■Relationship with the SPD instruction

Measurement time specified by operand of the SPD instruction is written in the special register for measuring unit time used by the rotational speed measurement function. Measurement results of the SPD instruction are also stored in the special register of measurement results.

If rotational speed measurement has already been started by the HIOEN instruction, the SPD instruction cannot be used for the same channel.

Inversely, if pulse density is currently being measured by the SPD instruction, rotational speed measurement cannot be started for the same channel.

■Other precautions

There are common precautions when using high-speed counters. For details, refer to  Page 163 Precautions when using high-speed counters.

High-speed comparison table

The high-speed comparison table is explained below.

Used to set high-speed comparison table for high-speed counters.

Sets match output setting for high-speed counters.

 Navigation window ⇒ [Parameter] ⇒ [FX5UCPU] ⇒ [Module Parameter] ⇒ [High Speed I/O] ⇒ "Input Function" ⇒ "High Speed Counter" ⇒ "Detail Setting" ⇒ "High Speed Compare Table"

Window

NO.	Counter CH	Comparison Type	Output Destination Device	Comparison Value 1 Specification Method	Comparison Value 1 Direct	Comparison Value 1 Indirect
1	Disable	Set		Direct Specification	0	
2	Disable	Set		Direct Specification	0	
3	Disable	Set		Direct Specification	0	
4	Disable	Set		Direct Specification	0	

Displayed items

Item	Description	Setting range	Default
Counter CH	Set the counter CH of coincidence output target.	Disable, CH1 to CH8	Disable
Comparison Type	Set comparison type.	<ul style="list-style-type: none"> Set Reset Self Reset Band Area Comparison 	Set
Output Destination Device	Sets output destination device for output comparison results of comparison value 1 and comparison value 2.	Bit device (Y, M), Interrupt pointer (I16 to I23)	—
Comparison Value 1 Specification Method	Sets the specification method of comparison value 1.	<ul style="list-style-type: none"> Direct Specification Indirect Specification 	Direct Specification
Comparison Value 1 Direct	Sets value (comparison value 1) to be compared with current value of high-speed counter. (When direct specification is selected)	$-2147483648 \leq \text{Comparison value 1} \leq 2147483647$	0
Comparison Value 1 Indirect	Sets device (comparison value 1) to be compared with current value of high-speed counter. (When indirect specification is selected)	Word device (D, R)	—
Comparison Value 2 Specification Method	If band comparison is set to comparison type, sets the specification method of comparison value 2.	<ul style="list-style-type: none"> Direct Specification Indirect Specification 	—
Comparison Value 2 Direct	If band comparison is set to comparison type, sets value (comparison value 2) to be compared with current value of high-speed counter. (When direct specification is selected)	$\text{Comparison value 1} \leq \text{Comparison value 2} \leq +2147483647$	—
Comparison Value 2 Indirect	If band comparison is set to comparison type, sets device (comparison value 2) to be compared with current value of high-speed counter. (When indirect specification is selected)	Word device (D, R)	—

Point

- You can create an open table entry before table setting is complete.
- Table settings can be made in any order. Be careful when the current value is changed by self-reset at a table along the way, as table processing starts with the first table then the following tables in order.

High-speed comparison table operation

Operation of each type of high-speed comparison table operation is explained below.

■Set to ON

When comparison value 1 matches the current value of the set high-speed counter, the bit device specified as the output destination device is set. If interrupt pointer has been specified for output destination device, the interrupt program of the specified interrupt pointer is run simultaneously when it matches comparison value 1.

Operation is the same as for the DHSCS instruction. For information on the DHSCS instruction, refer to  MELSEC iQ-F FX5 Programming Manual (Instructions, Standard Functions/Function Blocks).

■Reset

When comparison value 1 matches the current value of the set high-speed counter, the bit device specified as the output destination device is reset.

Operation is the same as for the DHSCR instruction. For information on the DHSCR instruction, refer to MELSEC iQ-F FX5 Programming Manual (Instructions, Standard Functions/Function Blocks).

■Self-reset

When comparison value 1 matches the current value of the set high-speed counter, the current value becomes the preset value. When the preset value is set by self-reset, comparison processing is not performed.

Operation is the same as self-reset for the DHSCR instruction. For information on the DHSCR instruction, refer to MELSEC iQ-F FX5 Programming Manual (Instructions, Standard Functions/Function Blocks).

■Zone Compare

Based on the current high-speed counter value, comparison value 1, and comparison value 3, one of the three output devices from the head output device will be set. The rest are reset.

		Set
Comparison value 1	> Current value	→ Head output device
Comparison value 1	≤ Current value ≤ Comparison value 2	→ Head output device +1
Current value	> Comparison value 2	→ Head output device +2

Operation is the same as for the DHSZ instruction. For information on zone comparison and DHSZ instruction, refer to MELSEC iQ-F FX5 Programming Manual (Instructions, Standard Functions/Function Blocks).

Comparison start/stop for high-speed comparison table

High-speed comparison tables cannot execute comparison by setting the parameter alone.

The HIOEN instruction is required to start/stop the high-speed comparison table.

For the HIOEN instruction, refer to MELSEC iQ-F FX5 Programming Manual (Instructions, Standard Functions/Function Blocks).

Point

The DHIOEN instruction is required to start/stop high-speed counters as well when using a high-speed comparison table.

Measurement is not conducted by starting the high-speed comparison table alone, and the high-speed comparison table therefore does not operate.

Precautions

■Number of tables that can be set

Up to 4 tables can be set. Empty tables are not included in the number of tables.

■Processing order

High-speed comparison tables are processed in sequence starting from the first table.

■Operation start timing

High-speed comparison tables are updated during END processing. If started/stopped by the DHIOEN instruction, the table is applied starting from the next scan. Caution must be exercised when controlling high-speed comparison tables using the DHIOEN instruction several times within the same scan.

Ex.

Table operation is as follows when multiple DHIOEN instructions are executed within the same scan.

Tables 1, 2 and 4 are started at the 1st DHIOEN instruction.

Tables 3 and 5 are started, and 2 and 4 are stopped at the 2nd DHIOEN instruction.

Table 2 is started and 5 is stopped at the 3rd DHIOEN instruction.

Tables 1, 2 and 3 operate.

■Operation when using internal clock

Self-reset cannot be used for channels set to internal clock by pulse input mode.

Other precautions

There are common precautions when using high-speed counters. For details, refer to  Page 163 Precautions when using high-speed counters.

Multiple point output, high-speed comparison tables

Multiple point output, high-speed comparison tables are explained below.

Use to set multiple point output, high-speed comparison tables for high-speed counters.

Sets match output table comparison setting for high-speed counters.

 Navigation window ⇒ [Parameter] ⇒ [FX5UCPU] ⇒ [Module Parameter] ⇒ [High Speed I/O] ⇒ "Input Function" ⇒ "High Speed counter" ⇒ "Detail Setting" ⇒ "Multi-point Output High Speed Compare Table"

Window

Table Data	Do Not Use Device	Counter CH	CH1		
Output Data	Bit Output	Points	1		
NO.	Enable/Disable	Device	Comparison Value	Output Device	Output Data (HEX)
1	Disable		0		
2	Disable		0		
3	Disable		0		
4	Disable		0		
5	Disable		0		
6	Disable		0		
7	Disable		0		
8	Disable		0		
9	Disable		0		
10	Disable		0		

Displayed items

Item	Description	Setting range	Default
Table Data	Sets whether or not to use user device for table data.	<ul style="list-style-type: none"> Do Not Use Device Use Device 	Do Not Use Device
Counter CH	Set Comparison Target CH.	CH1 to CH8	CH1
Output Data	Sets the type of output data.	<ul style="list-style-type: none"> Bit Output Word Output 	Bit Output
Points	Sets the number of output data points.	<ul style="list-style-type: none"> Bit Output 1 to 16 Word Output 1 to 2 	1
Enable/Disable	Sets whether to "enable" or "disable" table data.	<ul style="list-style-type: none"> Disable Enable 	Disable
Device	Set the device used for table data.	Word device (D, R)	—
Comparison Value	Sets value (comparison value) to be compared with current value of high-speed counter.	$-2147483648 \leq \text{Comparison value} \leq +2147483647$	—
Output Device	Sets the output destination device of output data.	<ul style="list-style-type: none"> Bit Output Y, M Word Output D, R 	—
Output Data (HEX)	Sets output data.	According to output device	—

Point

- When using user devices, you can change comparison value or output data while the program is running.
- When using user devices, each table occupies 4 devices. Word devices are used in order starting from the initial device.

Multiple point output, high-speed comparison table operation

Operation of each type high-speed comparison table is explained below.

■Bit output

When comparison value 1 matches the current value of the set high-speed counter, output data is transferred to the output devices.

Ex.

Bit output, initial output device: Y0, Output points: 16

Table number	Comparison value	Output data
Table 1	10	H0001
Table 2	13	HAAAA
Table 3	19	H0100

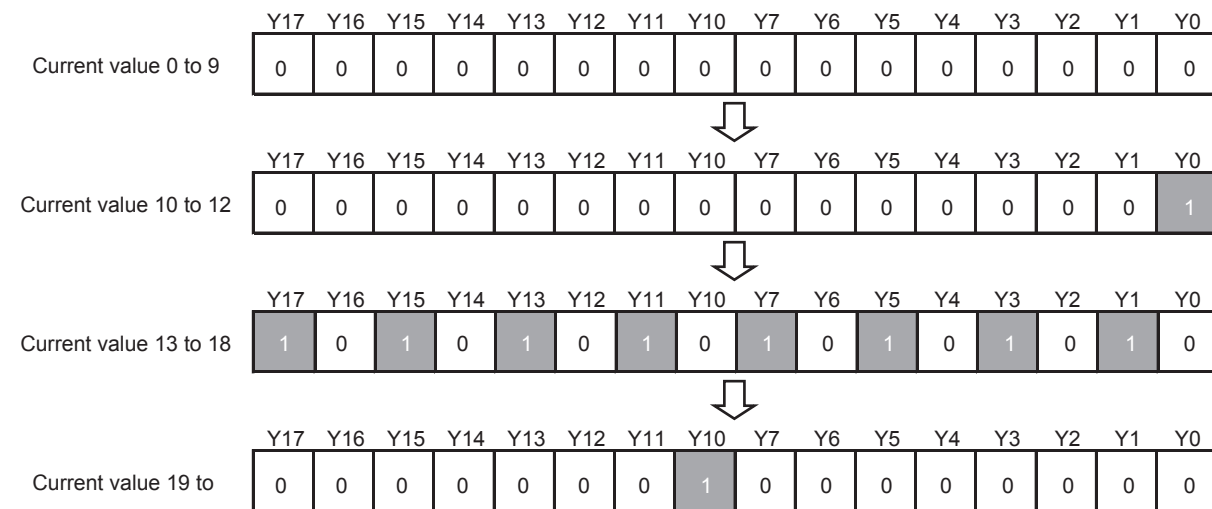

■Word output

When comparison value 1 matches the current value of the set high-speed counter, output data is transferred to the output devices.

Ex.

Word output, initial output device: D0, Output points: 1

Table number	Comparison value	Output data
Table 1	10	K100
Table 2	13	K300
Table 3	19	K10

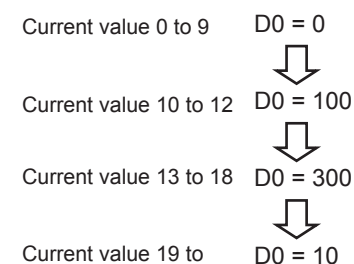

Comparison start/stop for multiple point output, high-speed comparison table

Multiple point output, high-speed comparison tables cannot execute comparison by setting the parameter alone.

The HIOEN instruction is required to start/stop multiple point output, high-speed comparison tables.

For the HIOEN instruction, refer to  MELSEC iQ-F FX5 Programming Manual (Instructions, Standard Functions/Function Blocks).

Point

The HIOEN instruction is required to start/stop high-speed counters as well when using a multiple point output, high-speed comparison table.

Measurement is not conducted by starting the multiple point output, high-speed comparison table alone, and the high-speed comparison table therefore does not operate.

Precautions

■Setting number

Up to 128 tables can be set.

■Device value when using user device

Parameters and user devices are handled as follows when using user devices.

Ex.

If D0 is set to initial device

Table number	User device	
	Comparison value	Output data
Table 1	D1, D0	D3, D2
Table 2	D5, D4	D7, D6
Table 3	D9, D8	D11, D10
Table 4	D13, D12	D15, D14
Table 5	D17, D16	D19, D18

■When final table comparison is complete

When comparison processing has been completed up to the last set table, SM5001 turns ON. The high-speed counter current value is not cleared.

■Operation start timing

Multiple point output, high-speed comparison tables are enabled as soon as the HIOEN instruction is executed.

■Table operation interval

The comparison value or input frequency must be set so the comparison value and high-speed counter current value match at intervals of 100 μ s or more for each table.

■Processing order

Multiple point output, high-speed comparison tables are processed in sequence starting from the first table. Only 1 table per count is processed.

■Table setting value update timing

When using user devices, you can change the table setting values by modifying the values of the device. However, the comparison value and output data values of the table currently being compared and the next table cannot be changed. If you modify the comparison values or output data, you can modify data of the next table in the sequence and those subsequent. The table number of which the table is being currently compared can be checked in the special register (SD5000).

■Other precautions

There are common precautions when using high-speed counters. For details, refer to  Page 163 Precautions when using high-speed counters.

Special relay list

A list of special relays used for high-speed counters is provided below.

Special relays for individual channels

A list of special relays by high-speed counter channel is provided below.

R/W: Read or Write

R: Read only

Special relay	Function	Operation		Default	R/W
		ON	OFF		
SM4500	High-speed counter operation (CH1)	Operating	Stopped	OFF	R
SM4501	High-speed counter operation (CH2)				
SM4502	High-speed counter operation (CH3)				
SM4503	High-speed counter operation (CH4)				
SM4504	High-speed counter operation (CH5)				
SM4505	High-speed counter operation (CH6)				
SM4506	High-speed counter operation (CH7)				
SM4507	High-speed counter operation (CH8)				
SM4508 to SM4515	Not used	—	—	—	—
SM4516	High-speed counter pulse density/Rotation speed measurement (CH1)	Measuring	Stopped	OFF	R
SM4517	High-speed counter pulse density/Rotation speed measurement (CH2)				
SM4518	High-speed counter pulse density/Rotation speed measurement (CH3)				
SM4519	High-speed counter pulse density/Rotation speed measurement (CH4)				
SM4520	High-speed counter pulse density/Rotation speed measurement (CH5)				
SM4521	High-speed counter pulse density/Rotation speed measurement (CH6)				
SM4522	High-speed counter pulse density/Rotation speed measurement (CH7)				
SM4523	High-speed counter pulse density/Rotation speed measurement (CH8)				
SM4524 to SM4531	Not used	—	—	—	—
SM4532	High-speed counter overflow (CH1)	Has occurred	Has not occurred	OFF	R/W
SM4533	High-speed counter overflow (CH2)				
SM4534	High-speed counter overflow (CH3)				
SM4535	High-speed counter overflow (CH4)				
SM4536	High-speed counter overflow (CH5)				
SM4537	High-speed counter overflow (CH6)				
SM4538	High-speed counter overflow (CH7)				
SM4539	High-speed counter overflow (CH8)				
SM4540 to SM4547	Not used	—	—	—	—
SM4548	High-speed counter underflow (CH1)	Has occurred	Has not occurred	OFF	R/W
SM4549	High-speed counter underflow (CH2)				
SM4550	High-speed counter underflow (CH3)				
SM4551	High-speed counter underflow (CH4)				
SM4552	High-speed counter underflow (CH5)				
SM4553	High-speed counter underflow (CH6)				
SM4554	High-speed counter underflow (CH7)				
SM4555	High-speed counter underflow (CH8)				
SM4556 to SM4563	Not used	—	—	—	—

Special relay	Function	Operation		Default	R/W
		ON	OFF		
SM4564	High-speed counter count direction monitor (CH1) (1-phase 2-input, 2-phase 2-input)	Down-counting	Up-counting	OFF	R
SM4565	High-speed counter count direction monitor (CH2) (1-phase 2-input, 2-phase 2-input)				
SM4566	High-speed counter count direction monitor (CH3) (1-phase 2-input, 2-phase 2-input)				
SM4567	High-speed counter count direction monitor (CH4) (1-phase 2-input, 2-phase 2-input)				
SM4568	High-speed counter count direction monitor (CH5) (1-phase 2-input, 2-phase 2-input)				
SM4569	High-speed counter count direction monitor (CH6) (1-phase 2-input, 2-phase 2-input)				
SM4570	High-speed counter count direction monitor (CH7) (1-phase 2-input, 2-phase 2-input)				
SM4571	High-speed counter count direction monitor (CH8) (1-phase 2-input, 2-phase 2-input)				
SM4572 to SM4579	Not used	—	—	—	—
SM4580	High-speed counter count direction switching (CH1) (1-phase 1-input S/W)	Down-counting	Up-counting	OFF	R/W
SM4581	High-speed counter count direction switching (CH2) (1-phase 1-input S/W)				
SM4582	High-speed counter count direction switching (CH3) (1-phase 1-input S/W)				
SM4583	High-speed counter count direction switching (CH4) (1-phase 1-input S/W)				
SM4584	High-speed counter count direction switching (CH5) (1-phase 1-input S/W)				
SM4585	High-speed counter count direction switching (CH6) (1-phase 1-input S/W)				
SM4586	High-speed counter count direction switching (CH7) (1-phase 1-input S/W)				
SM4587	High-speed counter count direction switching (CH8) (1-phase 1-input S/W)				
SM4588 to SM4595	Not used	—	—	—	—
SM4596	High-speed counter preset input logic (CH1)	Negative logic	Positive logic	Parameter setting values	R/W
SM4597	High-speed counter preset input logic (CH2)				
SM4598	High-speed counter preset input logic (CH3)				
SM4599	High-speed counter preset input logic (CH4)				
SM4600	High-speed counter preset input logic (CH5)				
SM4601	High-speed counter preset input logic (CH6)				
SM4602	High-speed counter preset input logic (CH7)				
SM4603	High-speed counter preset input logic (CH8)				
SM4604 to SM4611	Not used	—	—	—	—
SM4612	High-speed counter preset input comparison (CH1)	Valid	Invalid	Parameter setting values	R/W
SM4613	High-speed counter preset input comparison (CH2)				
SM4614	High-speed counter preset input comparison (CH3)				
SM4615	High-speed counter preset input comparison (CH4)				
SM4616	High-speed counter preset input comparison (CH5)				
SM4617	High-speed counter preset input comparison (CH6)				
SM4618	High-speed counter preset input comparison (CH7)				
SM4619	High-speed counter preset input comparison (CH8)				
SM4620 to SM4627	Not used	—	—	—	—

Special relay	Function	Operation		Default	R/W
		ON	OFF		
SM4628	High-speed counter enable input logic (CH1)	Negative logic	Positive logic	Parameter setting values	R/W
SM4629	High-speed counter enable input logic (CH2)				
SM4630	High-speed counter enable input logic (CH3)				
SM4631	High-speed counter enable input logic (CH4)				
SM4632	High-speed counter enable input logic (CH5)				
SM4633	High-speed counter enable input logic (CH6)				
SM4634	High-speed counter enable input logic (CH7)				
SM4635	High-speed counter enable input logic (CH8)				
SM4636 to SM4643	Not used	—	—	—	—
SM4644	High-speed counter ring length setting (CH1)	Valid	Invalid	Parameter setting values	R/W
SM4645	High-speed counter ring length setting (CH2)				
SM4646	High-speed counter ring length setting (CH3)				
SM4647	High-speed counter ring length setting (CH4)				
SM4648	High-speed counter ring length setting (CH5)				
SM4649	High-speed counter ring length setting (CH6)				
SM4650	High-speed counter ring length setting (CH7)				
SM4651	High-speed counter ring length setting (CH8)				
SM4652 to SM4659	Not used	—	—	—	—

Special relays shared by all channels

A list of special relays for high-speed counter shared by all channels is provided below.

R/W: Read or Write

R: Read only

Special relay	Function	Operation		Default	R/W
		ON	OFF		
SM4980	High-speed comparison table (high-speed compare instruction) operation	Operating	Stopped	OFF	R
SM4982	High-speed comparison table (high-speed compare instruction) error occurrence	Has occurred	Has not occurred	OFF	R/W
SM5000	Multi-point output high-speed comparison table operation	Operating	Stopped	OFF	R
SM5001	Multi-point output high-speed comparison table completion	Complete	Not complete	OFF	R/W

Special relay details

Details concerning special relays used for high-speed counters are explained below.

High-speed counter operating

Device for monitoring operation status of each channel of the high-speed counter.

■Corresponding devices

The device numbers corresponding to each channel are as follows.

CH1	CH2	CH3	CH4	CH5	CH6	CH7	CH8
SM4500	SM4501	SM4502	SM4503	SM4504	SM4505	SM4506	SM4507

■Operation Description

The content of the operation when ON and when OFF is as follows.

Operation when ON	Operation when OFF
High-speed counter operating	High-speed counter stopped



These devices also operate when the FX3 compatible high-speed counter function is valid.

■Update timing

The timing of device update is as follows.

ON	OFF
<ul style="list-style-type: none"> High-speed counter driven by the HIOEN instruction SPD instruction ON execution UDCNTF instruction is executed ON (when the FX3 compatible high-speed counter function is valid) 	<ul style="list-style-type: none"> High-speed counter stopped by the HIOEN instruction Power ON, reset, STOP, PAUSE UDCNTF instruction is executed OFF (when the FX3 compatible high-speed counter function is valid)

High-speed counter pulse density/rotational speed being measured

Device for monitoring operation of the high-speed counter when using pulse density/rotational speed measurement mode.

■Corresponding devices

The device numbers corresponding to each channel are as follows.

CH1	CH2	CH3	CH4	CH5	CH6	CH7	CH8
SM4516	SM4517	SM4518	SM4519	SM4520	SM4521	SM4522	SM4523

■Operation Description

The content of the operation when ON and when OFF is as follows.

Operation when ON	Operation when OFF
Pulse density/rotational speed measurement mode operating Updates measurement results by measuring unit time.	Pulse density/rotational speed measurement mode stopped or not being used



If the FX3 compatible high-speed counter function is valid, these devices operate only when the SPD instruction operates.

■Update timing

The timing of device update is as follows.

ON	OFF
<ul style="list-style-type: none"> Pulse density/rotational speed measurement mode is set in parameter and pulse density/rotational speed measurement is driven by the HIOEN instruction. SPD instruction ON execution 	<ul style="list-style-type: none"> Pulse density/rotational speed measurement mode is set in parameter and pulse density/rotational speed measurement is stopped by the HIOEN instruction. Power ON, reset, STOP, PAUSE

High-speed counter overflow

Flag that detects counter value overflow of high-speed counter.

■Corresponding devices

The device numbers corresponding to each channel are as follows.

CH1	CH2	CH3	CH4	CH5	CH6	CH7	CH8
SM4532	SM4533	SM4534	SM4535	SM4536	SM4537	SM4538	SM4539

■Operation Description

The content of the operation when ON and when OFF is as follows.

Operation when ON	Operation when OFF
Overflow occurs (Current value counted = +1 past maximum positive value)	Overflow does not occur

Point

- Does not operate when ring length setting is enabled.
- These devices also operate when the FX3 compatible high-speed counter function is valid.

■Update timing

The timing of device update is as follows.

ON	OFF
<ul style="list-style-type: none"> • Overflow occurs (This is updated with the END processing. When the FX3 compatible high-speed counter function is valid, the updating is made also when instruction UDCNTF instruction is executed ON.) 	<ul style="list-style-type: none"> • When OFF by the user • Power ON, reset • STOP/PAUSE→RUN • SM50 turned ON

High-speed counter underflow

Flag that detects counter value underflow of high-speed counter.

■Corresponding devices

The device numbers corresponding to each channel are as follows.

CH1	CH2	CH3	CH4	CH5	CH6	CH7	CH8
SM4548	SM4549	SM4550	SM4551	SM4552	SM4553	SM4554	SM4555

■Operation Description

The content of the operation when ON and when OFF is as follows.

Operation when ON	Operation when OFF
Underflow occurs (Current value counted = -1 past maximum negative value)	Underflow does not occur

Point

- Does not operate when ring length setting is enabled.
- These devices also operate when the FX3 compatible high-speed counter function is valid.

■Update timing

The timing of device update is as follows.

ON	OFF
<ul style="list-style-type: none"> • Underflow occurs (This is updated with the END processing. When the FX3 compatible high-speed counter function is valid, the updating is made also when UDCNTF instruction is executed ON.) 	<ul style="list-style-type: none"> • When OFF by the user • Power ON, reset • STOP/PAUSE→RUN • SM50 turned ON

High-speed counter (1-phase 2-input, 2-phase 2-input) count direction monitor

Device for monitoring counter direction when using 1-phase 2-input, 2-phase 2-input counter.

■Corresponding devices

The device numbers corresponding to each channel are as follows.

CH1	CH2	CH3	CH4	CH5	CH6	CH7	CH8
SM4564	SM4565	SM4566	SM4567	SM4568	SM4569	SM4570	SM4571

■Operation Description

The content of the operation when ON and when OFF is as follows.

Operation when ON	Operation when OFF
High-speed counter counting in direction whereby current value is reduced (Down-counting)	High-speed counter counting in direction whereby current value is increased (Up-counting)

Point

These devices also operate when the FX3 compatible high-speed counter function is valid.

■Update timing

The timing of device update is as follows.

ON	OFF
Down-counting (This is updated with the END processing. When the FX3 compatible high-speed counter function is valid, the updating is made also when UDCNTF instruction is executed ON.)	<ul style="list-style-type: none"> Up-counting (When the FX3 compatible high-speed counter function is valid, the updating is made also when UDCNTF instruction is executed ON.) Power ON, reset STOP/PAUSE→RUN

High-speed counter (1-phase 1-input S/W) (internal clock) count direction switch

Device for switching counter direction when using 1-phase 1-input (S/W) counter or internal clock.

■Corresponding devices

The device numbers corresponding to each channel are as follows.

CH1	CH2	CH3	CH4	CH5	CH6	CH7	CH8
SM4580	SM4581	SM4582	SM4583	SM4584	SM4585	SM4586	SM4587

■Operation Description

The content of the operation when ON and when OFF is as follows.

Operation when ON	Operation when OFF
High-speed counter current value counted -1 when phase A input ON	High-speed counter current value counted +1 when phase A input ON

Point

- Setting is ignored for counter other than 1-phase 1-input (S/W), internal clock.
- These devices also operate when the FX3 compatible high-speed counter function is valid.

■Update timing

The timing of device update is as follows.

ON	OFF
When ON by the user (update by END processing)	<ul style="list-style-type: none"> When OFF by the user (update by END processing) Power ON, reset STOP/PAUSE→RUN

Point

Can also be modified while the high-speed counter is operating.

High-speed counter preset input logic

These devices are used for setting the preset input logic.

■Corresponding devices

The device numbers corresponding to each channel are as follows.

CH1	CH2	CH3	CH4	CH5	CH6	CH7	CH8
SM4596	SM4597	SM4598	SM4599	SM4600	SM4601	SM4602	SM4603

■Operation Description

The content of the operation when ON and when OFF is as follows.

Operation when ON	Operation when OFF
The preset input operates with negative logic	The preset input operates with positive logic

Point

- The timing to execute the preset is determined by the preset input logic and the preset control switch.
- These devices also operate when the FX3 compatible high-speed counter function is valid.

■Update timing

The timing of device update is as follows.

ON	OFF
<ul style="list-style-type: none"> • When ON by the user • When set to negative logic with parameters 	<ul style="list-style-type: none"> • When OFF by the user • When set to positive logic with parameters

Point

Cannot be modified while the high-speed counter is operating. Operates in the configured status when the high-speed counter starts.

High-speed counter preset input comparison

These devices are used to specify whether or not to perform a comparison with the preset value when there is preset input.

■Corresponding devices

The device numbers corresponding to each channel are as follows.

CH1	CH2	CH3	CH4	CH5	CH6	CH7	CH8
SM4612	SM4613	SM4614	SM4615	SM4616	SM4617	SM4618	SM4619

■Operation Description

The content of the operation when ON and when OFF is as follows.

Operation when ON	Operation when OFF
Execute comparison processing with the preset value when there is preset input	Do not execute comparison processing when there is preset input

Point

These devices also operate when the FX3 compatible high-speed counter function is valid.

■Update timing

The timing of device update is as follows.

ON	OFF
<ul style="list-style-type: none">• When ON by the user• When set to enabled with parameters	<ul style="list-style-type: none">• When OFF by the user• When set to disabled with parameters

Point

- Cannot be modified while the high-speed counter is operating. Operates in the configured status when the high-speed counter starts.
- When the current value of a high-speed counter is rewritten with the DHCMOV instruction, the comparison process is not executed.
- When the preset control switch is set to "Constant when ON", the preset input comparison is disabled.

High-speed counter enable input logic

These devices are used for setting the enable input logic.

■Corresponding devices

The device numbers corresponding to each channel are as follows.

CH1	CH2	CH3	CH4	CH5	CH6	CH7	CH8
SM4628	SM4629	SM4630	SM4631	SM4632	SM4633	SM4634	SM4635

■Operation Description

The content of the operation when ON and when OFF is as follows.

Operation when ON	Operation when OFF
The enable input operates with negative logic (Enabled when the enable input is OFF)	The enable input operates with positive logic (Enabled when the enable input is ON)

Point

These devices also operate when the FX3 compatible high-speed counter function is valid.

■Update timing

The timing of device update is as follows.

ON	OFF
<ul style="list-style-type: none">• When ON by the user• When set to negative logic with parameters	<ul style="list-style-type: none">• When OFF by the user• When set to positive logic with parameters

Point

Cannot be modified while the high-speed counter is operating. Operates in the configured status when the high-speed counter starts.

High-speed counter ring length setting

These devices enable or disable the ring length setting for ring counters.

■Corresponding devices

The device numbers corresponding to each channel are as follows.

CH1	CH2	CH3	CH4	CH5	CH6	CH7	CH8
SM4644	SM4645	SM4646	SM4647	SM4648	SM4649	SM4650	SM4651

■Operation Description

The content of the operation when ON and when OFF is as follows.

Operation when ON	Operation when OFF
Enables the ring length setting for a ring counter (Counts in the range of 0 to ring length counter-1)	Disables the ring length setting for a ring counter (Counts in the range of -2147483648 to +2147483647)

Point

These devices do not operate when the FX3 compatible high-speed counter function is valid.

■Update timing

The timing of device update is as follows.

ON	OFF
<ul style="list-style-type: none"> When ON by the user When set to enabled with parameters 	<ul style="list-style-type: none"> When OFF by the user When set to disabled with parameters

Point

- Cannot be modified while the high-speed counter is operating. Operates in the configured status when the high-speed counter starts.
- The ring length setting is disabled if the pulse density measurement mode or rotational speed measurement mode is selected.

Precautions

If these devices are turned on when a high-speed counter's current value is out of the ring length range, the current value when the high-speed counter is operated is as follows.

- Lower than lower limit value → Lower limit value
- Higher than upper limit value → Upper limit value

High-speed comparison table (high-speed compare instruction) operation

This device is for monitoring the operational status of the high-speed counter's high-speed comparison table and the high-speed comparison instruction.

■Corresponding devices

The device number is shared for all channels.

CH1	CH2	CH3	CH4	CH5	CH6	CH7	CH8
SM4980							

■Operation Description

The content of the operation when ON and when OFF is as follows.

Operation when ON	Operation when OFF
High-speed comparison table operating When the high-speed counter current value and the high-speed comparison table set value or the DHSCS, DHSCR, DHSZ instruction set value are equal, the specified bit device is set or reset.	High-speed comparison table stopped Even when the high-speed counter current value and the high-speed comparison table set value or the DHSCS, DHSCR, DHSZ instruction set value are equal, the specified bit device does not change.

Point

These devices also operate when the FX3 compatible high-speed counter function is valid.

■Update timing

The timing of device update is as follows.

ON	OFF
<ul style="list-style-type: none"> Match output driven by the DHIOEN instruction ON execution by DHSCS, DHSCR, DHSZ instruction 	<ul style="list-style-type: none"> Match output stopped by the DHIOEN instruction and DHSCS, DHSCR, DHSZ instructions all OFF Power ON, reset, STOP, PAUSE

High-speed comparison table (high-speed compare instruction) error occurrence

This device turns ON when driving the DHSCS, DHSCR, DHSZ instructions in excess of the limitation of the number of instructions driven at the same time.

■Corresponding devices

The device number is shared for all channels.

CH1	CH2	CH3	CH4	CH5	CH6	CH7	CH8
SM4982							

■Operation Description

The content of the operation when ON and when OFF is as follows.

Operation when ON	Operation when OFF
DHSCS, DHSCR, DHSZ instructions operated in excess of the limitation of the number of instructions driven at the same time	When there is no error DHSCS, DHSCR, DHSZ instructions can operate

Point

- Even when this device turns ON, the DHSCS, DHSCR, DHSZ instructions within the range of the number of instructions driven at the same time will operate. For the limitation of the number of instructions driven at the same time, refer to  MELSEC iQ-F FX5 Programming Manual (Instructions, Standard Functions/Function Blocks).
- These devices also operate when the FX3 compatible high-speed counter function is valid.

■Update timing

The timing of device update is as follows.

ON	OFF
<ul style="list-style-type: none"> • Updated in END processing • If an error occurs while the FX3 compatible DHSCS, DHSCR, and DHSZ instruction ON execution, an operation is made also when the high-speed counter function is valid. 	<ul style="list-style-type: none"> • When OFF by the user • Power ON, reset

Multi-point output high-speed comparison table operation

This device is for monitoring the operational status of the high-speed counter's multi-point output high-speed comparison tables.

■Corresponding devices

The device number is shared for all channels.

CH1	CH2	CH3	CH4	CH5	CH6	CH7	CH8
SM5000							

■Operation Description

The content of the operation when ON and when OFF is as follows.

Operation when ON	Operation when OFF
Multi-point output high-speed comparison table operating When the high-speed counter current value is equal to the set value specified in the multi-point output high-speed comparison table parameters, the specified pattern of output or the data transfer operates.	Multi-point output high-speed comparison tables stopped Even when the high-speed counter current value is equal to the set value specified in the multi-point output high-speed comparison table parameters, the specified pattern of output or the data transfer is not executed.

Point

These devices also operate when the FX3 compatible high-speed counter function is valid.

■Update timing

The timing of device update is as follows.

ON	OFF
<ul style="list-style-type: none"> Match output driven by the HIOEN instruction ON execution by DHSCS, DHSCR, DHSZ instruction 	<ul style="list-style-type: none"> Match output stopped by the HIOEN instruction and DHSCS, DHSCR, DHSZ instructions all OFF Power ON, reset, STOP, PAUSE SM8034 turned ON

Multi-point output high-speed comparison table completion

This device turns ON when the high-speed counter's multi-point output high-speed comparison tables have finished comparing all of the set tables.

■Corresponding devices

The device number is shared for all channels.

CH1	CH2	CH3	CH4	CH5	CH6	CH7	CH8
SM5001							

■Operation Description

The content of the operation when ON and when OFF is as follows.

Operation when ON	Operation when OFF
Multi-point output high-speed comparison table completion The comparison of the final table has finished	Multi-point output high-speed comparison tables not finished The comparison has not finished up to the final table



These devices also operate when the FX3 compatible high-speed counter function is valid.

■Update timing

The timing of device update is as follows.

ON	OFF
When multi-point output high-speed comparison tables have finished processing the set amount of tables	<ul style="list-style-type: none"> When OFF by the user Power ON, reset, STOP, PAUSE

Special registers list

The following list shows the special registers used with high-speed counters. All set values except for ring length are handled as signed.

Special registers for individual channels

The following list shows the special registers for individual high-speed counter channels.

R/W: Read or Write

R: Read only

Special register	Function	Range	Default	R/W
SD4500	High-speed counter current value (CH1)	-2147483648 to +2147483647	0	R/W
SD4501				
SD4502	High-speed counter maximum value (CH1)	-2147483648 to +2147483647	-2147483648	R/W
SD4503				
SD4504	High-speed counter minimum value (CH1)	-2147483648 to +2147483647	2147483647	R/W
SD4505				
SD4506	High-speed counter pulse density (CH1)	0 to 2147483647	0	R/W
SD4507				
SD4508	High-speed counter rotational speed (CH1)	0 to 2147483647	0	R/W
SD4509				
SD4510	High-speed counter preset control switch (CH1)	0: Rising edge 1: Falling edge 2: Both edges 3: Constant when ON	Parameter set value	R/W
SD4511	Not used	—	—	—
SD4512	High-speed counter preset value (CH1)	-2147483648 to +2147483647	Parameter set value	R/W
SD4513				
SD4514	High-speed counter ring length (CH1)	2 to 2147483647	Parameter set value	R/W
SD4515				
SD4516	High-speed counter measurement unit time (CH1)	1 to 2147483647	Parameter set value	R/W
SD4517				
SD4518	High-speed counter number of pulses per rotation (CH1)	1 to 2147483647	Parameter set value	R/W
SD4519				
SD4520 to SD4529	Not used	—	—	—
SD4530	High-speed counter current value (CH2)	-2147483648 to +2147483647	0	R/W
SD4531				
SD4532	High-speed counter maximum value (CH2)	-2147483648 to +2147483647	-2147483648	R/W
SD4533				
SD4534	High-speed counter minimum value (CH2)	-2147483648 to +2147483647	2147483647	R/W
SD4535				
SD4536	High-speed counter pulse density (CH2)	0 to 2147483647	0	R/W
SD4537				
SD4538	High-speed counter rotational speed (CH2)	0 to 2147483647	0	R/W
SD4539				
SD4540	High-speed counter preset control switch (CH2)	0: Rising edge 1: Falling edge 2: Both edges 3: Constant when ON	Parameter set value	R/W
SD4541	Not used	—	—	—
SD4542	High-speed counter preset value (CH2)	-2147483648 to +2147483647	Parameter set value	R/W
SD4543				
SD4544	High-speed counter ring length (CH2)	2 to 2147483647	Parameter set value	R/W
SD4545				
SD4546	High-speed counter measurement unit time (CH2)	1 to 2147483647	Parameter set value	R/W
SD4547				

Special register	Function	Range	Default	R/W
SD4548	High-speed counter number of pulses per rotation (CH2)	1 to 2147483647	Parameter set value	R/W
SD4549				
SD4550 to SD4559	Not used	—	—	—
SD4560	High-speed counter current value (CH3)	-2147483648 to +2147483647	0	R/W
SD4561				
SD4562	High-speed counter maximum value (CH3)	-2147483648 to +2147483647	-2147483648	R/W
SD4563				
SD4564	High-speed counter minimum value (CH3)	-2147483648 to +2147483647	2147483647	R/W
SD4565				
SD4566	High-speed counter pulse density (CH3)	0 to 2147483647	0	R/W
SD4567				
SD4568	High-speed counter rotational speed (CH3)	0 to 2147483647	0	R/W
SD4569				
SD4570	High-speed counter preset control switch (CH3)	0: Rising edge 1: Falling edge 2: Both edges 3: Constant when ON	Parameter set value	R/W
SD4571	Not used	—	—	—
SD4572	High-speed counter preset value (CH3)	-2147483648 to +2147483647	Parameter set value	R/W
SD4573				
SD4574	High-speed counter ring length (CH3)	2 to 2147483647	Parameter set value	R/W
SD4575				
SD4576	High-speed counter measurement unit time (CH3)	1 to 2147483647	Parameter set value	R/W
SD4577				
SD4578	High-speed counter number of pulses per rotation (CH3)	1 to 2147483647	Parameter set value	R/W
SD4579				
SD4580 to SD4589	Not used	—	—	—
SD4590	High-speed counter current value (CH4)	-2147483648 to +2147483647	0	R/W
SD4591				
SD4592	High-speed counter maximum value (CH4)	-2147483648 to +2147483647	-2147483648	R/W
SD4593				
SD4594	High-speed counter minimum value (CH4)	-2147483648 to +2147483647	2147483647	R/W
SD4595				
SD4596	High-speed counter pulse density (CH4)	0 to 2147483647	0	R/W
SD4597				
SD4598	High-speed counter rotational speed (CH4)	0 to 2147483647	0	R/W
SD4599				
SD4600	High-speed counter preset control switch (CH4)	0: Rising edge 1: Falling edge 2: Both edges 3: Constant when ON	Parameter set value	R/W
SD4601	Not used	—	—	—
SD4602	High-speed counter preset value (CH4)	-2147483648 to +2147483647	Parameter set value	R/W
SD4603				
SD4604	High-speed counter ring length (CH4)	2 to 2147483647	Parameter set value	R/W
SD4605				
SD4606	High-speed counter measurement unit time (CH4)	1 to 2147483647	Parameter set value	R/W
SD4607				
SD4608	High-speed counter number of pulses per rotation (CH4)	1 to 2147483647	Parameter set value	R/W
SD4609				
SD4610 to SD4619	Not used	—	—	—
SD4620	High-speed counter current value (CH5)	-2147483648 to +2147483647	0	R/W
SD4621				

Special register	Function	Range	Default	R/W
SD4622	High-speed counter maximum value (CH5)	-2147483648 to +2147483647	-2147483648	R/W
SD4623				
SD4624	High-speed counter minimum value (CH5)	-2147483648 to +2147483647	2147483647	R/W
SD4625				
SD4626	High-speed counter pulse density (CH5)	0 to 2147483647	0	R/W
SD4627				
SD4628	High-speed counter rotational speed (CH5)	0 to 2147483647	0	R/W
SD4629				
SD4630	High-speed counter preset control switch (CH5)	0: Rising edge 1: Falling edge 2: Both edges 3: Constant when ON	Parameter set value	R/W
SD4631	Not used	—	—	—
SD4632	High-speed counter preset value (CH5)	-2147483648 to +2147483647	Parameter set value	R/W
SD4633				
SD4634	High-speed counter ring length (CH5)	2 to 2147483647	Parameter set value	R/W
SD4635				
SD4636	High-speed counter measurement unit time (CH5)	1 to 2147483647	Parameter set value	R/W
SD4637				
SD4638	High-speed counter number of pulses per rotation (CH5)	1 to 2147483647	Parameter set value	R/W
SD4639				
SD4640 to SD4649	Not used	—	—	—
SD4650	High-speed counter current value (CH6)	-2147483648 to +2147483647	0	R/W
SD4651				
SD4652	High-speed counter maximum value (CH6)	-2147483648 to +2147483647	-2147483648	R/W
SD4653				
SD4654	High-speed counter minimum value (CH6)	-2147483648 to +2147483647	2147483647	R/W
SD4655				
SD4656	High-speed counter pulse density (CH6)	0 to 2147483647	0	R/W
SD4657				
SD4658	High-speed counter rotational speed (CH6)	0 to 2147483647	0	R/W
SD4659				
SD4660	High-speed counter preset control switch (CH6)	0: Rising edge 1: Falling edge 2: Both edges 3: Constant when ON	Parameter set value	R/W
SD4661	Not used	—	—	—
SD4662	High-speed counter preset value (CH6)	-2147483648 to +2147483647	Parameter set value	R/W
SD4663				
SD4664	High-speed counter ring length (CH6)	2 to 2147483647	Parameter set value	R/W
SD4665				
SD4666	High-speed counter measurement unit time (CH6)	1 to 2147483647	Parameter set value	R/W
SD4667				
SD4668	High-speed counter number of pulses per rotation (CH6)	1 to 2147483647	Parameter set value	R/W
SD4669				
SD4670 to SD4679	Not used	—	—	—
SD4680	High-speed counter current value (CH7)	-2147483648 to +2147483647	0	R/W
SD4681				
SD4682	High-speed counter maximum value (CH7)	-2147483648 to +2147483647	-2147483648	R/W
SD4683				
SD4684	High-speed counter minimum value (CH7)	-2147483648 to +2147483647	2147483647	R/W
SD4685				
SD4686	High-speed counter pulse density (CH7)	0 to 2147483647	0	R/W
SD4687				

Special register	Function	Range	Default	R/W
SD4688	High-speed counter rotational speed (CH7)	0 to 2147483647	0	R/W
SD4689				
SD4690	High-speed counter preset control switch (CH7)	0: Rising edge 1: Falling edge 2: Both edges 3: Constant when ON	Parameter set value	R/W
SD4691	Not used	—	—	—
SD4692	High-speed counter preset value (CH7)	-2147483648 to +2147483647	Parameter set value	R/W
SD4693				
SD4694	High-speed counter ring length (CH7)	2 to 2147483647	Parameter set value	R/W
SD4695				
SD4696	High-speed counter measurement unit time (CH7)	1 to 2147483647	Parameter set value	R/W
SD4697				
SD4698	High-speed counter number of pulses per rotation (CH7)	1 to 2147483647	Parameter set value	R/W
SD4699				
SD4700 to SD4709	Not used	—	—	—
SD4710	High-speed counter current value (CH8)	-2147483648 to +2147483647	0	R/W
SD4711				
SD4712	High-speed counter maximum value (CH8)	-2147483648 to +2147483647	-2147483648	R/W
SD4713				
SD4714	High-speed counter minimum value (CH8)	-2147483648 to +2147483647	2147483647	R/W
SD4715				
SD4716	High-speed counter pulse density (CH8)	0 to 2147483647	0	R/W
SD4717				
SD4718	High-speed counter rotational speed (CH8)	0 to 2147483647	0	R/W
SD4719				
SD4720	High-speed counter preset control switch (CH8)	0: Rising edge 1: Falling edge 2: Both edges 3: Constant when ON	Parameter set value	R/W
SD4721	Not used	—	—	—
SD4722	High-speed counter preset value (CH8)	-2147483648 to +2147483647	Parameter set value	R/W
SD4723				
SD4724	High-speed counter ring length (CH8)	2 to 2147483647	Parameter set value	R/W
SD4725				
SD4726	High-speed counter measurement unit time (CH8)	1 to 2147483647	Parameter set value	R/W
SD4727				
SD4728	High-speed counter number of pulses per rotation (CH8)	1 to 2147483647	Parameter set value	R/W
SD4729				
SD4730 to SD4739	Not used	—	—	—

Special registers shared by all channels

The following list shows the special registers shared by all high-speed counter channels.

R/W: Read or Write

R: Read only

Special register	Function	Range	Default	R/W
SD4982	High-speed comparison table (high-speed compare instruction) error occurrence error code	0: When there is no error 1811H: Over the number of instructions driven at the same time	0	R/W
SD5000	Multi-point output high-speed comparison table comparison number	0 to 128	0	R

Special register details

This section describes details about the special registers used with the high-speed counters.

High-speed counter current value

These devices store the current values of the high-speed counters.

■Corresponding devices

The device numbers corresponding to each channel are as follows.

CH1	CH2	CH3	CH4	CH5	CH6	CH7	CH8
SD4501, SD4500	SD4531, SD4530	SD4561, SD4560	SD4591, SD4590	SD4621, SD4620	SD4651, SD4650	SD4681, SD4680	SD4711, SD4710

■Description

These devices stores the current values of the high-speed counters.

These are signed 32-bit ring counters. (Upper limit value+1 changes to → lower limit value, lower limit value-1 changes to → upper limit value.)

When the ring length is not set, lower limit value: -2147483648, upper limit value: 2147483647.

When the ring length is set, lower limit value: 0, upper limit value: ring length-1.

Point

- To rewrite the current value, use the HCMOV instruction and transfer the desired value. However, this is the upper limit when set to a value that exceeds the upper limit value, and this is the lower limit value when set to a value that is less than the lower limit value.
- If the current value falls outside the ring length range when the ring length is set, the upper and lower limit values of the ring length are ignored and the current value is used.
- The current value is retained even when the power is OFF.

■Update timing

The current value of the high-speed counter is updated in END processing or when the HCMOV instruction is executed.

Further, when the FX3 compatible high-speed counter function is valid, the value is updated also when UDCNTF instruction is executed.

■Clear timing

The timing when the device is cleared is as follows.

- Cleared by the DHCMOV instruction
- When the RST LC□ instruction executes ON (only when the FX3 compatible high-speed counter function is valid and the applicable LC device is used)
- Power ON, reset, RUN→STOP (only when the FX3 compatible high-speed counter function is valid and the applicable LC device is used)

High-speed counter maximum value

These devices store the maximum values of the high-speed counters.

■Corresponding devices

The device numbers corresponding to each channel are as follows.

CH1	CH2	CH3	CH4	CH5	CH6	CH7	CH8
SD4503, SD4502	SD4533, SD4532	SD4563, SD4562	SD4593, SD4592	SD4623, SD4622	SD4653, SD4652	SD4683, SD4682	SD4713, SD4712

■Description

These devices stores the maximum values of the high-speed counters.

Point

- To rewrite the maximum value, only the HCMOV instruction can be used.
- These devices also operate when the FX3 compatible high-speed counter function is valid.

■Update timing

When the current value of a high-speed counter exceeds the maximum value, the value is updated in END processing. When the value is read using the HCMOV instruction, it is first updated to the latest value and then read. Further, when the FX3 compatible high-speed counter function is valid, the value is updated also when UDCNTF instruction is executed.

■Clear timing

The timing when the device is cleared is as follows.

- Power ON, Reset

High-speed counter minimum value

These devices store the minimum values of the high-speed counters.

■Corresponding devices

The device numbers corresponding to each channel are as follows.

CH1	CH2	CH3	CH4	CH5	CH6	CH7	CH8
SD4505, SD4504	SD4535, SD4534	SD4565, SD4564	SD4595, SD4594	SD4625, SD4624	SD4655, SD4654	SD4685, SD4684	SD4715, SD4714

■Description

These devices stores the minimum values of the high-speed counters.

Point

- To rewrite the minimum value, only the HCMOV instruction can be used.
- These devices also operate when the FX3 compatible high-speed counter function is valid.

■Update timing

When the current value of a high-speed counter becomes less than the minimum value, the value is updated in END processing. When the value is read using the HCMOV instruction, it is first updated to the latest value and then read. Further, when the FX3 compatible high-speed counter function is valid, the value is updated also when UDCNTF instruction is executed.

■Clear timing

The timing when the device is cleared is as follows.

- Power ON, Reset

High-speed counter pulse density

These devices store the measurement results of pulse density measurement mode.

■Corresponding devices

The device numbers corresponding to each channel are as follows.

CH1	CH2	CH3	CH4	CH5	CH6	CH7	CH8
SD4507, SD4506	SD4537, SD4536	SD4567, SD4566	SD4597, SD4596	SD4627, SD4626	SD4657, SD4656	SD4687, SD4686	SD4717, SD4716

■Description

These devices store the measurement results of pulse density measurement mode (rotational speed measurement mode).

Point

- These devices also store the pulse density measurement when in rotational speed measurement mode.
- If the FX3 compatible high-speed counter function is valid, these devices operate only when the SPD instruction operates.

■Update timing

The pulse density is updated at each measurement unit time when set to pulse density measurement mode (rotational speed measurement mode) with parameters.

■Clear timing

The timing when the device is cleared is as follows.

- Power ON, Reset, STOP/PAUSE→RUN

High-speed counter rotational speed

These devices store the measurement results of rotational speed measurement mode.

■Corresponding devices

The device numbers corresponding to each channel are as follows.

CH1	CH2	CH3	CH4	CH5	CH6	CH7	CH8
SD4509, SD4508	SD4539, SD4538	SD4569, SD4568	SD4599, SD4598	SD4629, SD4628	SD4659, SD4658	SD4689, SD4688	SD4719, SD4718

■Description

These devices store the measurement results of rotational speed measurement mode.

Point

- These devices also store the rotational speed when in pulse density measurement mode.
- These devices do not operate when the FX3 compatible high-speed counter function is valid.

■Update timing

The rotational speed is updated at each measurement unit time when set to rotational speed measurement mode with parameters.

■Clear timing

The timing when the device is cleared is as follows.

- Power ON, Reset, STOP/PAUSE→RUN

High-speed counter preset control switch

These devices set the preset input operation of the high-speed counters.

■Corresponding devices

The device numbers corresponding to each channel are as follows.

CH1	CH2	CH3	CH4	CH5	CH6	CH7	CH8
SD4510	SD4540	SD4570	SD4600	SD4630	SD4660	SD4690	SD4720

■Description

These devices set the timing to execute preset input. The table below shows the operations of the setting values.

Setting value	Description
0	Executes the preset on the rising edge.
1	Executes the preset on the falling edge.
2	Executes the preset on both edges.
3	Constantly executes the preset when ON.*1
Other than above	Operates as the rising edge. Executes the preset on the rising edge.

*1 When the preset control switch is set to "3: Constant when ON", the preset input comparison cannot be used even if the parameter of the preset input comparison (special relay) is enabled.

Point

- While the high-speed counter is operating, the value is not reflected even if modified. It operates in the status when the high-speed counter starts.
- These devices also operate when the FX3 compatible high-speed counter function is valid.

■Clear timing

The timing when the device is cleared is as follows.

- Power ON, Reset, STOP→RUN

■Description of operation

This section describes the operations when the preset input logic and the preset control switch are combined. The preset value is set to 0.

- Operation when preset input logic: positive logic, preset control switch: rising edge

The preset is executed when the preset input changes OFF→ON.

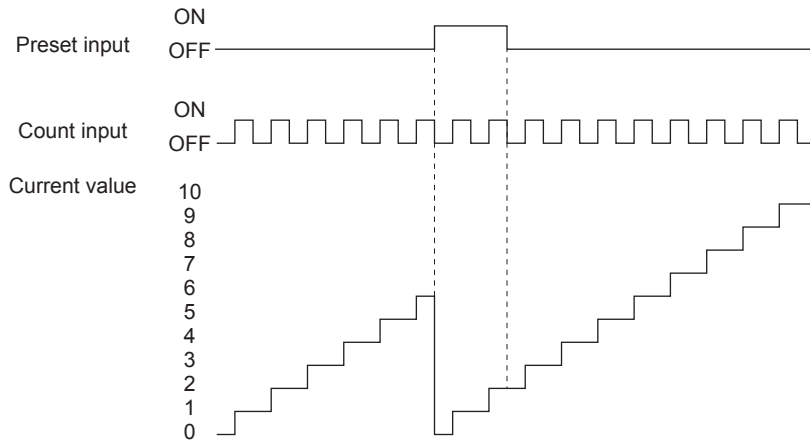

- Operation when preset input logic: positive logic, preset control switch: falling edge

The preset is executed when the preset input changes ON→OFF.

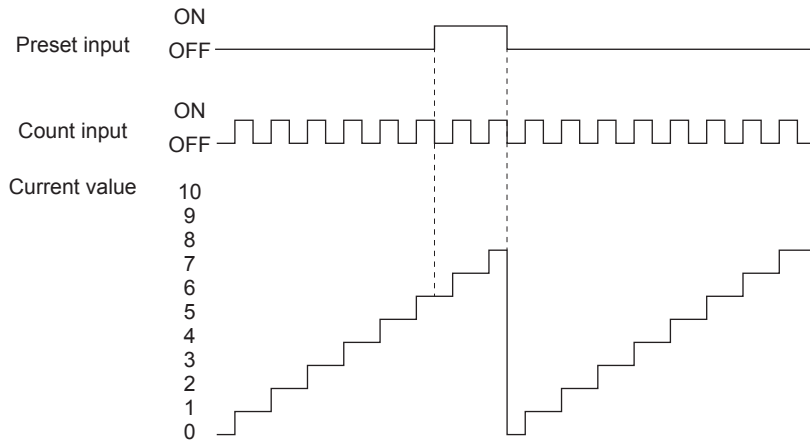

- Operation when preset input logic: positive logic, preset control switch: rising edge + falling edge

The preset is executed when the preset input changes OFF→ON and when it changes ON→OFF.

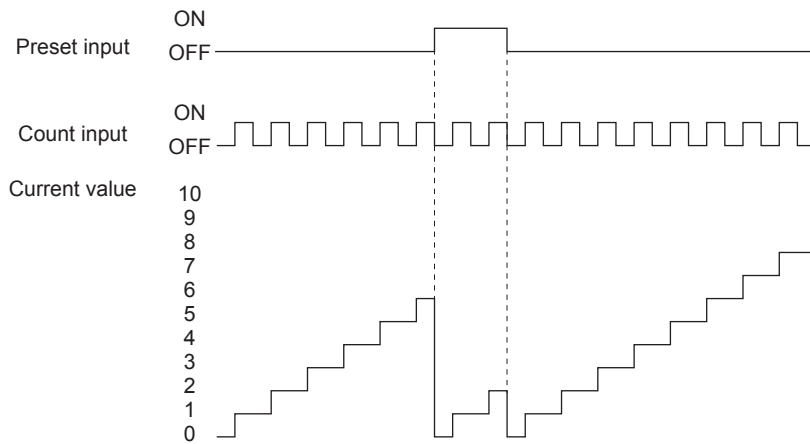

- Operation when preset input logic: positive logic, preset control switch: constant when ON
The preset is constantly executed while the preset input is ON.

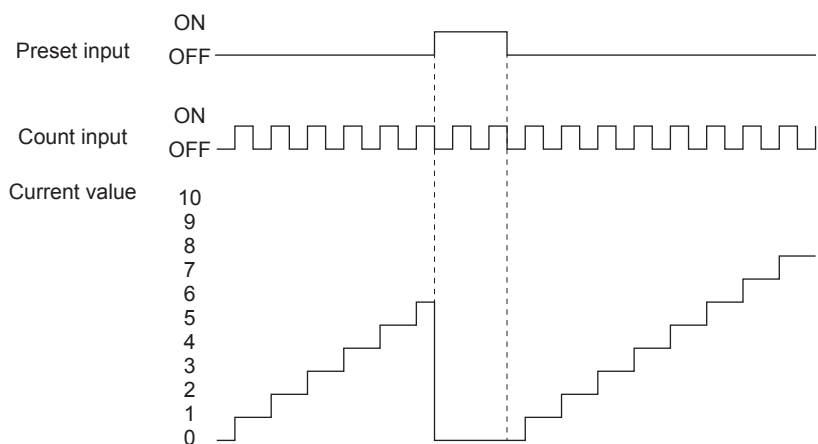

- Operation when preset input logic: negative logic, preset control switch: rising edge
The preset is executed when the preset input changes ON→OFF.

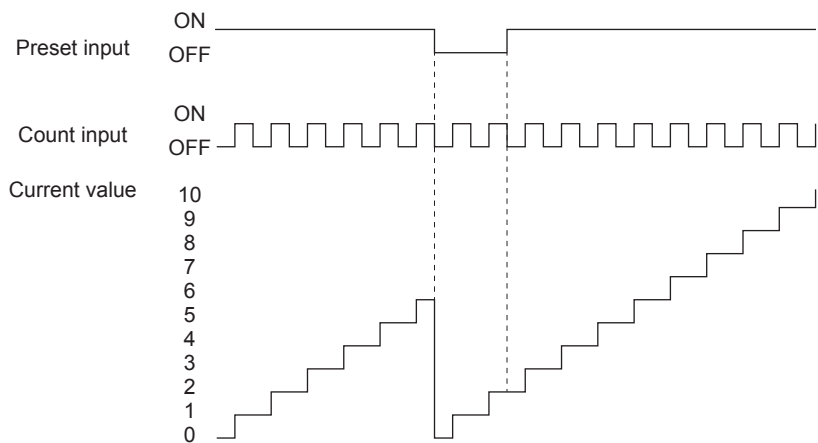

- Operation when preset input logic: negative logic, preset control switch: falling edge
The preset is executed when the preset input changes OFF→ON.

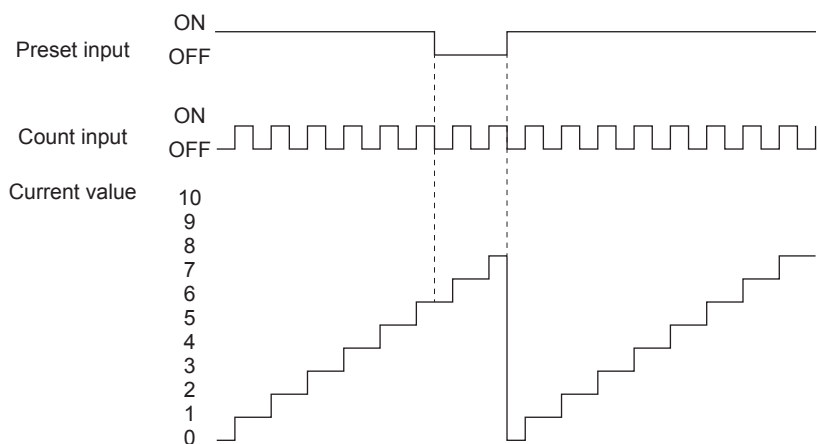

- Operation when preset input logic: negative logic, preset control switch: rising edge + falling edge
The preset is executed when the preset input changes ON→OFF and when it changes OFF→ON.

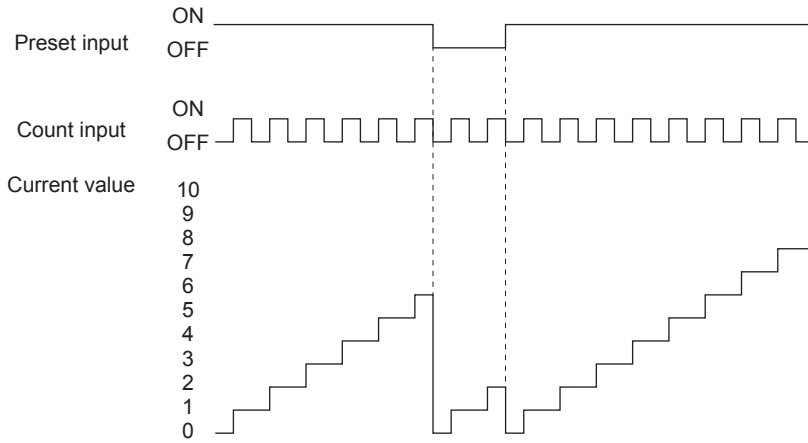

- Operation when preset input logic: negative logic, preset control switch: constant when ON
The preset is constantly executed while the preset input is OFF.

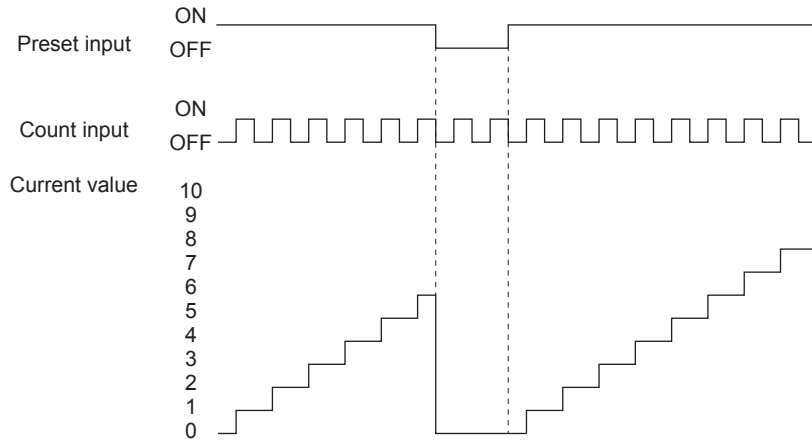

High-speed counter preset value

These devices set the values to store in the current values when presets are executed.

■Corresponding devices

The device numbers corresponding to each channel are as follows.

CH1	CH2	CH3	CH4	CH5	CH6	CH7	CH8
SD4513, SD4512	SD4543, SD4542	SD4573, SD4572	SD4603, SD4602	SD4633, SD4632	SD4663, SD4662	SD4693, SD4692	SD4723, SD4722

■Description

These devices set the values to set for the current values when presets are executed.

If the preset value is set to be greater than the ring length, an error occurs when the high-speed counter is started.

Point

- The preset value can also be modified while the high-speed counter is operating. The update timing is END processing.
- These devices also operate when the FX3 compatible high-speed counter function is valid.

■Clear timing

The timing when the device is cleared is as follows.

- Power ON, Reset, STOP→RUN

High-speed counter ring length

These devices set the ring length of the high-speed counters.

■Corresponding devices

The device numbers corresponding to each channel are as follows.

CH1	CH2	CH3	CH4	CH5	CH6	CH7	CH8
SD4515, SD4514	SD4545, SD4544	SD4575, SD4574	SD4605, SD4604	SD4635, SD4634	SD4665, SD4664	SD4695, SD4694	SD4725, SD4724

■Description

These devices set the ring length of the high-speed counters.

These set values are valid when the ring length setting is set to enabled.

Point

- While the high-speed counter is operating, the value is not reflected even if modified. It operates in the status when the high-speed counter starts.
- These devices do not operate when the FX3 compatible high-speed counter function is valid.

■Clear timing

The timing when the device is cleared is as follows.

- Power ON, Reset, STOP→RUN

Precautions

If the ring length is set to less than the lower limit value or more than the upper limit value, the ring length operates at the lower limit value or the upper limit value. However, the set value is stored as is.

High-speed counter measurement unit time

These devices set the measurement unit of pulse density measurement mode.

■Corresponding devices

The device numbers corresponding to each channel are as follows.

CH1	CH2	CH3	CH4	CH5	CH6	CH7	CH8
SD4517, SD4516	SD4547, SD4546	SD4577, SD4576	SD4607, SD4606	SD4637, SD4636	SD4667, SD4666	SD4697, SD4696	SD4727, SD4726

■Description

These devices set the time to measure pulse density (rotational speed) in 1 ms units when high-speed counters are operating in pulse density measurement mode.

Point

- If the value is modified while the high-speed counter is operating, the rewritten value is reflected after the measurement before the value was modified is finished.
- If the FX3 compatible high-speed counter function is valid, these devices operate only when the SPD instruction operates. The value in the operand of the SPD instruction is written.

■Clear timing

The timing when the device is cleared is as follows.

- Power ON, Reset, STOP→RUN

Precautions

If the set value for the measurement unit time is set to less than the lower limit value or more than the upper limit value, the measurement unit time operates at the lower limit value or the upper limit value. However, the set value is stored as is.

High-speed counter number of pulses per rotation

These devices set the number of pulses per rotation for rotational speed measurement mode.

■Corresponding devices

The device numbers corresponding to each channel are as follows.

CH1	CH2	CH3	CH4	CH5	CH6	CH7	CH8
SD4519, SD4518	SD4549, SD4548	SD4579, SD4578	SD4609, SD4608	SD4639, SD4638	SD4669, SD4668	SD4699, SD4698	SD4729, SD4728

■Description

These devices set the number of pulses per rotation when a high-speed counter operates in rotational speed measurement mode. The rotational speed is measured with the set value.

Point

- If the value is modified while the high-speed counter is operating, the rewritten value is reflected after the measurement before the value was modified is finished.
- These devices do not operate when the FX3 compatible high-speed counter function is valid.

■Clear timing

The timing when the device is cleared is as follows.

- Power ON, Reset, STOP→RUN

Precautions

If the set value for the number of pulses per rotation is set to less than the lower limit value or more than the upper limit value, the number of pulses per rotation operates at the lower limit value or the upper limit value. However, the set value is stored as is.

High-speed comparison table (high-speed compare instruction) error occurrence error code

This device stores the high-speed comparison table, high-speed comparison instruction error.

■Corresponding devices

The device number is shared for all channels.

CH1	CH2	CH3	CH4	CH5	CH6	CH7	CH8
SD4982							

■Description

This device stores the error code when an error occurs in the high-speed comparison table, high-speed comparison instruction.

Point

These devices also operate when the FX3 compatible high-speed counter function is valid.

■Clear timing

The timing when the device is cleared is as follows.

- Power ON, Reset, SM50 turned ON

■Error code

Over the upper limit of the number of instructions driven at the same time: 1811H

Multi-point output high-speed comparison table comparison number

This device stores the number of the table currently being compared in the multi-point output high-speed comparison tables.

■Corresponding devices

The device number is shared for all channels.

CH1	CH2	CH3	CH4	CH5	CH6	CH7	CH8
SD5000							

■Description

This device stores the number of the table currently being compared in the multi-point output high-speed comparison tables. If 0, the multi-point output high-speed comparison tables have stopped.

Point

- When rewriting the comparison value or output data for the multi-point output high-speed comparison tables, the table numbers from the table numbers that follow after the next table number of the table being compared can be rewritten.
- The table number being compared and the next table number after that can be rewritten, but they will not be compared.
- These devices also operate when the FX3 compatible high-speed counter function is valid.

■Clear timing

The timing when the device is cleared is as follows.

- Power ON, Reset, STOP→RUN

Special relays/special registers capable of high-speed transfers with the HCMOV instruction

The table below shows the devices that can read and write the latest value with the HCMOV instruction from special relays and special registers related to the high-speed counters. When special relays and special registers are specified for (s) and (d) of instructions other than the HCMOV instruction, the operation is the same as one compatible with the MOV instruction.

Special relays for individual channels

- : High-speed transfer capable (special relay is immediately updated)
- △: Normal transfer capable (special relay is updated in END processing)
- ×: Transfer not possible (read-only)

Special relay	Function	Compatible with HCMOV instruction		Compatible with MOV instruction	
		(s)	(d)	(s)	(d)
SM4500 to SM4507	High-speed counter operating	△	×	△	×
SM4516 to SM4523	High-speed counter pulse density/rotational speed being measured	△	×	△	×
SM4532 to SM4539	High-speed counter overflow	○	○	△	△
SM4548 to SM4555	High-speed counter underflow	○	○	△	△
SM4564 to SM4571	High-speed counter (1-phase 2-input, 2-phase 2-input) count direction monitor	○	×	△	×
SM4580 to SM4587	High-speed counter (1-phase 1-input S/W) count direction switch	△	○	△	△
SM4596 to SM4603	High-speed counter preset input logic	△	△	△	△
SM4612 to SM4619	High-speed counter preset input comparison	△	△	△	△
SM4628 to SM4635	High-speed counter enable input logic	△	△	△	△
SM4644 to SM4651	High-speed counter ring length setting	△	△	△	△

Special relays shared by all channels

- : High-speed transfer capable (special relay is immediately updated)
- △: Normal transfer capable (special relay is updated in END processing)
- ×: Transfer not possible (read-only)

Special relay	Function	Compatible with HCMOV instruction		Compatible with MOV instruction	
		(s)	(d)	(s)	(d)
SM4980	High-speed comparison table (high-speed compare instruction) operation	△	×	△	×
SM4982	High-speed comparison table (high-speed compare instruction) error occurrence	△	△	△	△
SM5000	Multi-point output high-speed comparison table operation	△	×	△	×
SM5001	Multi-point output high-speed comparison table completion	○	△	△	△

Special registers for individual channels

This section only lists the devices for high-speed counter CH1. The devices for high-speed counter CH2 and subsequent counters have the same operation as CH1.

○: High-speed transfer capable (special register is immediately updated)

△: Normal transfer capable (special register is updated in END processing)

×: Transfer not possible (read-only)

Special register	Function	Compatible with HCMOV instruction		Compatible with MOV instruction	
		(s)	(d)	(s)	(d)
SD4500	High-speed counter current value (CH1)	○	○	△	×
SD4501					
SD4502	High-speed counter maximum value (CH1)	○	○	△	×
SD4503					
SD4504	High-speed counter minimum value (CH1)	○	○	△	×
SD4505					
SD4506	High-speed counter pulse density (CH1)	△	△	△	△
SD4507					
SD4508	High-speed counter rotational speed (CH1)	△	△	△	△
SD4509					
SD4510	High-speed counter preset control switch (CH1)	△	△	△	△
SD4512	High-speed counter preset value (CH1)	○	○	△	△
SD4513					
SD4514	High-speed counter ring length (CH1)	△	△	△	△
SD4515					
SD4516	High-speed counter measurement unit time (CH1)	△	△	△	△
SD4517					
SD4518	High-speed counter number of pulses per rotation (CH1)	△	△	△	△
SD4519					

Point

Always use DHCMOV (32-bit instruction) for devices that use 2 words. When the HCMOV instruction (16-bit instruction) is used, it operates the same as the normal MOV instruction.

Special registers shared by all channels

○: High-speed transfer capable (special register is immediately updated)

△: Normal transfer capable (special register is updated in END processing)

×: Transfer not possible (read-only)

Special register	Function	Compatible with HCMOV instruction		Compatible with MOV instruction	
		(s)	(d)	(s)	(d)
SD4982	High-speed comparison table (high-speed compare instruction) error occurrence error code	△	△	△	△
SD5000	Multi-point output high-speed comparison table comparison number	△	×	△	△

Precautions when using high-speed counters

This section describes the precautions when using high-speed counters.

Common precautions when using high-speed counter instructions and parameters

This section describes the common precautions when using high-speed comparison tables and multi-point output comparison tables with the high-speed counter instructions (DHSCS, DHSCR, DHSZ instructions) or parameters. For the individual precautions on high-speed counter instructions, refer to [MELSEC iQ-F FX5 Programming Manual \(Instructions, Standard Functions/Function Blocks\)](#).

High-speed counter devices

The current values for high-speed counters are checked with special registers for each channel.

To start or stop counting of the high-speed counters, use the HIOEN instruction or the SPD instruction.

- High-speed counter start/stop conditions

Function	Start	Stop
Counting	<ul style="list-style-type: none"> • HIOEN instruction • SPD instruction 	<ul style="list-style-type: none"> • HIOEN instruction • SPD instruction*¹
Comparison processing	<ul style="list-style-type: none"> • HIOEN instruction • DHSCS, DHSCR, DHSZ instructions 	<ul style="list-style-type: none"> • HIOEN instruction • DHSCS, DHSCR, DHSZ instructions*²

*1 Can be stopped when counting was started with the SPD instruction.

*2 Can be stopped when the high-speed comparison table is not set with parameters.

Precautions for the counting operation when the current value is changed

For the high-speed counter instructions, high-speed comparison tables, and multi-point output high-speed comparison tables, comparison processing is performed when the current value of the high-speed counter has changed due to pulse input. When the preset input comparison function is also enabled, comparison processing is also performed when the preset is executed. However, please note that the comparison processing is not performed when the current value of the high-speed counter is changed with the following methods.

- When the current value of a high-speed counter was rewritten with the HCMOV instruction.
- When the current value of the high-speed counter is reset with the RST instruction or the ZRST instruction (when the FX3 compatible high-speed counter function is valid)
- When the current value of the high-speed counter was changed by a self-reset. (When the preset input comparison function is disabled)
- When high-speed counter current value is the ON or OFF output result of the comparison of the DHSCS, DHSCR, DHSZ instructions.
- When high-speed counter current value is the ON or OFF output result of the comparison of a high-speed comparison table.

Preset input comparison operation

When the preset input comparison is enabled and preset control switching is set to constant when ON, the preset input comparison does not operate.

Timing at which the instruction is enabled

The DHSCS, DHSCR, DHSZ instructions are enabled at the END instruction for the scan in which the instructions are driven. Even when the comparison value is changed, it is updated at the END instruction for the scan in which it was changed.

Configuring high-speed comparison tables with parameters

Operations of DHSCS, DHSCR, DHSZ instructions of the same comparison value are executed after high-speed comparison tables set with parameters. The high-speed comparison table is processed sequentially from the top of the table.

■High-speed counter current value modification operation by instructions

The table below shows the operations when the current value of a high-speed counter is rewritten by instructions.

Instruction	High-speed counter current value
HCMOV instruction	☞ Page 161 Special relays/special registers capable of high-speed transfers with the HCMOV instruction
MOV instruction, etc.	
RST instruction	Cannot reset. The special register value is overwritten in END processing.
ZRST instruction	Cannot reset. The special register value is overwritten in END processing.

■Limitation in the number of instances of each instruction in a program and number of instructions driven at the same time

When DHSCS, DHSCR, DHSZ instructions are driven at the same time in excess of the upper limit, the instructions after the upper limit do not operate.

Instruction	Limitation in number of instructions driven at same time
DHSCS	Up to 4 instructions can be driven at the same time.
DHSCR	There is no limitation in the number used in programs.
DHSZ	

- Configuring high-speed comparison tables with parameters

When configuring high-speed comparison tables with parameters, the number of instructions driven at the same time decreases by 1 for each table setting.

Restriction

Set up the program and configure the settings within the range calculated with the following equation due to the limitations described above.

$$4 \geq \text{Number of driven high-speed comparison tables} + \text{Number of DHSCS, DHSCR, DHSZ instructions driven at the same time}$$

■Operation when the all output disable flag (SM8034) is ON

When the all output disable flag (SM8034) is turned ON, the outputs that were turned ON by high-speed comparison tables, high-speed comparison instructions, or multi-point output high-speed tables are turned OFF. (The image remains ON.)

If SM8034 is turned OFF, the outputs that were turned OFF return to the original state.

For high-speed comparison tables and high-speed comparison instructions, high-speed counters do not stop and comparison processing is performed even when SM8034 is ON, and the image turns ON if there is a match. The actual output is output when SM8034 is OFF.

For multi-point output high-speed comparison tables, the high-speed counter for which the multi-point output high-speed comparison table is operating is stopped when SM8034 is turned ON, and multi-point output comparison processing is also stopped. High-speed counters and multi-point output high-speed comparison tables cannot be operated by turning OFF SM8034 and need to be restarted by the HIOEN instruction.

The normal high-speed counter function continues to perform counting without being influenced by SM8034.

19.2 FX3-compatible high-speed counter function

FX3-compatible high-speed counter function is explained below.

FX3-compatible high-speed counter function overview

The FX3 compatible high-speed counter can assign the input terminals compatible with FX3 and use the device equivalent to C235 to C255 of FX3 as LC35 to LC55 (high-speed counter).

If the FX3 compatible high-speed counter is used, it is necessary to use the parameter to set the FX3 compatible high-speed counter to be valid.

This section describes the device (LC35 to LC55) of the FX3 compatible high-speed counter as an LC device.

Point

The FX3 compatible high-speed counter is convenient if it is used when a replacement is made from FX3 or for a similar occasion. If a high-speed counter is newly used, use the high-speed counter function of FX5. (Page 114 High-speed Counter Function)

How to start/stop the high-speed counter using the LC device

The method of starting/stopping the counting of the high-speed counter using the LC device is as follows.

Programs example

In the case of a program shown below, the counting starts when M0 turns ON, and the counting stops when M0 turns OFF. When the counter increases from -6 or less to -5 or higher during an execution of the UDCNTF instruction, the counter contact turns ON, and the counter contact turns OFF when the counter decreases from -5 or higher to -6 or lower.

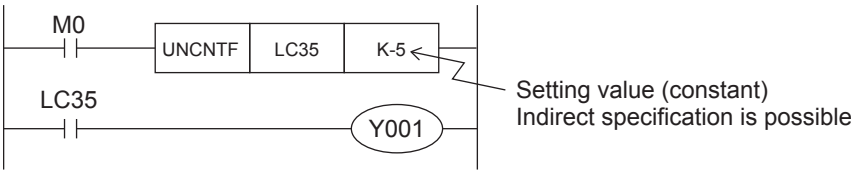

Point

- The current value of LC35 is updated when the UDCNTF instruction is executed.
- When LC35 is set to (s) of the DHCMOV instruction, the newest value can be read out.
- When a high-speed comparison instruction (DHSCS instruction, DHSCR instruction, DHSZ instruction), a high-speed comparison table, or a multi-point output high-speed comparison table are used, an accurate comparison and matched output processing can be executed.

The set value (positive or negative) can be specified by a constant (K) or the contents of data registers (D). When data registers are used, 32-bit data composed of two consecutive devices are treated as set values. If D0 is specified, the pair of D1 and D0 are the setting value of 32 bits.

Operation example

The operation of LC35 in the programming example described above is as shown below.

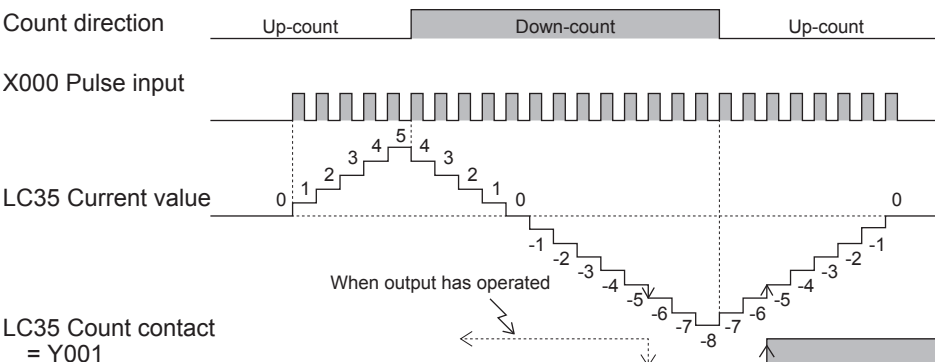

The elements of the composition of the LC device

Each element that composes the LC device is shown below.

Item	Description
Counting coil	This is the activation contact to start the counting of the LC device. When the UDCNTF instruction is turned OFF/ON, the status turns ON and the counting of the input signal becomes possible.
Setting value	This is K□ specified with UDCNTF LC□ K□. An indirect specification is acceptable.
Current value	This is the current value of the counter. The value increases or decreases depending on the input pulse.
Counter contact	This turns ON when the current value of the LC device changes from a value less than the setting value to the setting value or higher. This can be used as LD LC□.
Reset coil	This turns ON when the RST instruction with the LC device specified turns OFF→ON, and turns OFF when the RST instruction turns ON→OFF. When the reset coil is ON, the counting is not executed even if the count coil is ON, and the current value is always 0.

The comparison between the UDCNTF instruction and HIOEN instruction

The comparison between the UDCNTF instruction and the HIOEN instruction is described below.

The availability of use when the FX3 compatibility function is enable/disable

FX3-compatible function enable/disable	UDCNTF instruction	HIOEN instruction
Disable	—	○
Enable	○	○

○: Use

—: Not use



The LC device can be used as a high-speed counter only when the FX3 compatible function is valid. However, this is only the LC device that is set up with parameter. Also, it is possible to use the HIOEN instruction.

Starting/stopping the counting of the high-speed counter

The start and stop of the counting of the high-speed counter of the UDCNTF instructions and HIOEN instructions with the FX3 compatible function valid are described below.

For the UDCNTF instruction or HIOEN instruction, refer to MELSEC iQ-F FX5 Programming Manual (Instructions, Standard Functions/Function Blocks).

Starting/stopping the counting of the high-speed counter	UDCNTF instruction	HIOEN instruction
The start of the high-speed counter	○	○
The simultaneous start of multiple CH	×	○
The simultaneous stop of multiple CH	×	○
The start→stop and the stop→start of the same CH in one scan	○	○
The stop of the counter started by the UDCNTF instructions in the same step	○	—
The stop of the counter started by the UDCNTF instructions in a different step	○	×
The stop of the counter started by the HIOEN instruction the same step	—	○
The stop of the counter started by the HIOEN instruction a different step	○	○

○: Supported

×: Not supported

—: Not applicable

- If the UDCNTF instructions and HIOEN instructions are used for the same CH, it is not possible to use the HIOEN instruction to stop the high-speed counter started by UDCNTF instructions. On the other hand, the instruction started by the HIOEN instruction can be stopped by executing ON→OFF of UDCNTF instructions. Use caution when the HIOEN instruction and UDCNTF instructions are used together.
- Do not drive the same LC device number at the same time.

The operation of each element of the current value of a started counter and the LC device

Shown below is the operations of the SD device, the current value of the LC device, and each element of the LC device when the counting is started with UDCNTF instructions or is started with the HIOEN instruction while the FX3 compatible function is valid.

The current value of the SD device, each element of the LC device	The start with UDCNTF instruction	The start with HIOEN instruction
The current value of the SD device	○	○
The current value of the LC device	○	○
The LC device counting coil	○	×
The counter contact point of the LC device	○	×
The reset coil of the LC device	○	○

○: Operate

×: Not operate

- When a count is started by HIOEN instruction, although LC device changes, neither a counting coil nor the counter contact operates. Moreover, when operation is started by HIOEN instruction and LC□ corresponding to CH is reset, during the RST instruction ON, operation is stopped and calculation is resumed in OFF of the RST instruction.

Assignment for FX3-compatible high-speed counters

The high-speed counter number that can be specified with each CH

Shown here are the high-speed counter numbers (C235 to C255) of FX3 that can be selected with each CH

CH	High-speed counter No.	Pulse input mode	Corresponding devices	Preset input logic change
CH1	C235	1-phase 1-count (S/W)	LC35	—
CH1	C241	1-phase 1-count (S/W)	LC41	○
CH1	C244	1-phase 1-count (S/W)	LC44	○
CH1	C246	1-phase 2-count	LC46	—
CH1	C247	1-phase 2-count	LC47	○
CH1	C249	1-phase 2-count	LC49	○
CH1	C251	2-phase 2-count (1 edge count/4 edge count)	LC51	—
CH1	C252	2-phase 2-count (1 edge count/4 edge count)	LC52	○
CH1	C254	2-phase 2-count (1 edge count/4 edge count)	LC54	○
CH2	C236	1-phase 1-count (S/W)	LC36	—
CH3	C237	1-phase 1-count (S/W)	LC37	—
CH3	C242	1-phase 1-count (S/W)	LC42	○
CH3	C245	1-phase 1-count (S/W)	LC45	○
CH4	C238	1-phase 1-count (S/W)	LC38	—
CH4	C248	1-phase 2-count	LC48	○
CH4	C248 (OP)	1-phase 2-count	LC48	—
CH4	C250	1-phase 2-count	LC50	○
CH4	C253	2-phase 2-count (1 edge count/4 edge count)	LC53	○

CH	High-speed counter No.	Pulse input mode	Corresponding devices	Preset input logic change
CH4	C253 (OP)	2-phase 2-count (1 edge count/4 edge count)	LC53	—
CH4	C255	2-phase 2-count (1 edge count/4 edge count)	LC55	○
CH5	C239	1-phase 1-count (S/W)	LC39	—
CH5	C243	1-phase 1-count (S/W)	LC43	○
CH6	C240	1-phase 1-count (S/W)	LC40	—
CH7	C244 (OP)	1-phase 1-count (S/W)	LC44	—
CH7	C254 (OP)	2-phase 2-count (1 edge count)	LC54	—
CH8	C245 (OP)	1-phase 1-count (H/W)	LC45	—

○: Change is possible

—: Change is impossible

The assignment of the high-speed counter and the maximum frequency when the FX3 compatible function is valid

Shown below is the assignment of the high-speed counter and the maximum frequency when the FX3 compatible function is valid.

CH	High-speed counter No.	FX5 corresponding devices	X0	X1	X2	X3	X4	X5	X6	X7	Maximum frequency	
											CPU module (32 points type)	CPU module (64 points or more type)
CH1	C235	LC35	A								200 KHz	200 KHz
CH2	C236	LC36		A							200 KHz	200 KHz
CH3	C237	LC37			A						200 KHz	200 KHz
CH4	C238	LC38				A					200 KHz	200 KHz
CH5	C239	LC39					A				200 KHz	200 KHz
CH6	C240	LC40						A			200 KHz	200 KHz
CH1	C241	LC41	A	P							200 KHz	200 KHz
CH3	C242	LC42			A	P					200 KHz	200 KHz
CH5	C243	LC43					A	P			200 KHz	200 KHz
CH1	C244	LC44	A	P					E		200 KHz	200 KHz
CH7	C244 (OP)	LC44							A		10 KHz	200 KHz
CH3	C245	LC45			A	P				E	200 KHz	200 KHz
CH8	C245 (OP)	LC45								A	10 KHz	200 KHz
CH1	C246	LC46	A	B							200 KHz	200 KHz
CH1	C247	LC47	A	B	P						200 KHz	200 KHz
CH4	C248	LC50				A	B	P			200 KHz	200 KHz
CH4	C248 (OP)	LC50				A	B				200 KHz	200 KHz
CH1	C249	LC49	A	B	P				E		200 KHz	200 KHz
CH4	C250	LC50				A	B	P		E	200 KHz	200 KHz
CH1	C251 (1 edge count)	LC51	A	B							200 KHz	200 KHz
CH1	C251 (4 edge count)	LC51	A	B							50 KHz	50 KHz
CH1	C252 (1 edge count)	LC52	A	B	P						200 KHz	200 KHz
CH1	C252 (4 edge count)	LC52	A	B	P						50 KHz	50 KHz
CH4	C253 (1 edge count)	LC53				A	B	P			200 KHz	200 KHz
CH4	C253 (4 edge count)	LC53				A	B	P			50 KHz	50 KHz
CH4	C253 (OP) (1 edge count)	LC53				A	B				200 KHz	200 KHz
CH4	C253 (OP) (4 edge count)	LC53				A	B				50 KHz	50 KHz
CH1	C254 (1 edge count)	LC54	A	B	P				E		200 KHz	200 KHz
CH1	C254 (4 edge count)	LC54	A	B	P				E		50 KHz	50 KHz
CH7	C254 (OP)	LC54							A	B	10 KHz	200 KHz
CH4	C255 (1 edge count)	LC55				A	B	P		E	200 KHz	200 KHz
CH4	C255 (1 edge count)	LC55				A	B	P		E	50 KHz	50 KHz

A: A phase input, B: Phase B input, P: External preset input, E: External enable input

FX3-compatible high-speed counter setting

This section describes the setting of the case when the FX3 compatible high-speed counter is used.

FX3-compatible high-speed counter are set by GX Works3.





Point

- If a high-speed comparison table or a multi-point output high-speed comparison table is used, it is necessary to set the parameter in the same manner as the FX5 high-speed counter.
- It is necessary to specify also the input response time.

Parameter setting

FX3-compatible high-speed counter parameter setting method is explained below.

For parameter setting of each operation, refer to the following.

- For FX3-compatible high-speed counters, refer to  Page 169 FX3-compatible high-speed counter.
- For high-speed comparison table, refer to  Page 132 High-speed comparison table.
- For multiple point output, high-speed comparison tables, refer to  Page 134 Multiple point output, high-speed comparison tables.
- For input response time, refer to  Page 191 General-purpose Input Functions.

FX3-compatible high-speed counter

FX3 compatible high-speed counter setting method is explained below.

1. Set the method of specifying the high-speed counter to "long counter setting".

 Navigation window ⇒ [Parameter] ⇒ [FX5UCPU] ⇒ [Module Parameter] ⇒ [High Speed I/O] ⇒ "Input Function" ⇒ "High Speed Counter" ⇒ "Detail Setting" ⇒ "Other"

Window

Item	CH
<i>Specification method for high speed counter</i>	Select the high speed counter of input assignment which is compatible with FX3 series.
Specification method for high speed counter	Long Counter Specification

Displayed items

Item	Description	Setting range	Default
Specification method for high speed counter	Set up whether or not to use FX3 compatibility assignment for high speed counter. <ul style="list-style-type: none"> • When using FX5 high-speed counter, choose "normal". • When using FX3 compatible high-speed counter, choose "long counter specification". 	<ul style="list-style-type: none"> • Normal • Long Counter Specification 	Normal

2. Set up the FX3 compatible high-speed counter.

The counter number and function that can be specified are different from CH to CH. ( Page 167 Assignment for FX3-compatible high-speed counters)

 Navigation window ⇒ [Parameter] ⇒ [FX5UCPU] ⇒ [Module Parameter] ⇒ [High Speed I/O] ⇒ "Input Function" ⇒ "High Speed Counter" ⇒ "Detail Setting" ⇒ "Basic Settings"

Window

Item	CH1	CH2
Use/Do Not Use Counter	Set whether to use counter or not.	
Use/Not Use	Enable	Disable
Counter device	Select the high speed counter of input assignment which is compatible with FX3 series.	
Counter device	LC35 (Operation equivalent to C235)	LC36 (Operation equivalent to C236)
Operation Mode	Set operation mode.	
Operation Mode	Normal Mode	Normal Mode
Pulse Input Mode	Set pulse input mode.	
Pulse Input Mode	1-Phase 1 Input (S/W Up/Down Switch)	1-Phase 1 Input (S/W Up/Down Switch)
Preset Input	Set present.	
Preset Input Enable/Disable	Disable	Disable
Input logic	Positive Logic	Positive Logic
Preset Value	0	0
Input Comparison Enable/Disable	Enable	Enable
Control Switch	Rising	Rising
Enable Input	Set enable input.	
Enable Input Enable/Disable	Disable	Disable
Input logic	Positive Logic	Positive Logic
Ring Length Setting	Set ring length.	
Ring Length Enable/Disable	Disable	Disable
Ring Length	2147483648	2147483648
Measurement Unit Time	Set measurement unit time.	
Measurement Unit Time	1000	1000
Pulse No. of per Rotation	Set the pulse No. of per rotation.	
Pulse No. of per Rotation	1000	1000

Displayed items

Item	Description	Setting range	Default																
Use/Not Use	Set whether use counter or not.	<ul style="list-style-type: none"> • Disable • Enable 	—																
Counter device	Select the high speed counter of input assignment which is compatible with FX3.	<table border="1"> <tbody> <tr> <td>CH1</td> <td> <ul style="list-style-type: none"> • LC35 (Operation equivalent to C235) • LC41 (Operation equivalent to C241) • LC44 (Operation equivalent to C244) • LC46 (Operation equivalent to C246) • LC47 (Operation equivalent to C247) • LC49 (Operation equivalent to C249) • LC51 (Operation equivalent to C251) • LC52 (Operation equivalent to C252) • LC54 (Operation equivalent to C254) </td> </tr> <tr> <td>CH2</td> <td> <ul style="list-style-type: none"> • LC36 (Operation equivalent to C236) </td> </tr> <tr> <td>CH3</td> <td> <ul style="list-style-type: none"> • LC37 (Operation equivalent to C237) • LC42 (Operation equivalent to C242) • LC45 (Operation equivalent to C245) </td> </tr> <tr> <td>CH4</td> <td> <ul style="list-style-type: none"> • LC38 (Operation equivalent to C238) • LC48 (Operation equivalent to C248) • LC50 (Operation equivalent to C250) • LC53 (Operation equivalent to C253) • LC55 (Operation equivalent to C255) • LC48 (Operation equivalent to C248(OP)) • LC53 (Operation equivalent to C253(OP)) </td> </tr> <tr> <td>CH5</td> <td> <ul style="list-style-type: none"> • LC39 (Operation equivalent to C239) • LC43 (Operation equivalent to C243) </td> </tr> <tr> <td>CH6</td> <td> <ul style="list-style-type: none"> • LC40 (Operation equivalent to C240) </td> </tr> <tr> <td>CH7</td> <td> <ul style="list-style-type: none"> • LC44 (Operation equivalent to C244(OP)) • LC54 (Operation equivalent to C254(OP)) </td> </tr> <tr> <td>CH8</td> <td> <ul style="list-style-type: none"> • LC45 (Operation equivalent to C245) </td> </tr> </tbody> </table>	CH1	<ul style="list-style-type: none"> • LC35 (Operation equivalent to C235) • LC41 (Operation equivalent to C241) • LC44 (Operation equivalent to C244) • LC46 (Operation equivalent to C246) • LC47 (Operation equivalent to C247) • LC49 (Operation equivalent to C249) • LC51 (Operation equivalent to C251) • LC52 (Operation equivalent to C252) • LC54 (Operation equivalent to C254) 	CH2	<ul style="list-style-type: none"> • LC36 (Operation equivalent to C236) 	CH3	<ul style="list-style-type: none"> • LC37 (Operation equivalent to C237) • LC42 (Operation equivalent to C242) • LC45 (Operation equivalent to C245) 	CH4	<ul style="list-style-type: none"> • LC38 (Operation equivalent to C238) • LC48 (Operation equivalent to C248) • LC50 (Operation equivalent to C250) • LC53 (Operation equivalent to C253) • LC55 (Operation equivalent to C255) • LC48 (Operation equivalent to C248(OP)) • LC53 (Operation equivalent to C253(OP)) 	CH5	<ul style="list-style-type: none"> • LC39 (Operation equivalent to C239) • LC43 (Operation equivalent to C243) 	CH6	<ul style="list-style-type: none"> • LC40 (Operation equivalent to C240) 	CH7	<ul style="list-style-type: none"> • LC44 (Operation equivalent to C244(OP)) • LC54 (Operation equivalent to C254(OP)) 	CH8	<ul style="list-style-type: none"> • LC45 (Operation equivalent to C245) 	—
CH1	<ul style="list-style-type: none"> • LC35 (Operation equivalent to C235) • LC41 (Operation equivalent to C241) • LC44 (Operation equivalent to C244) • LC46 (Operation equivalent to C246) • LC47 (Operation equivalent to C247) • LC49 (Operation equivalent to C249) • LC51 (Operation equivalent to C251) • LC52 (Operation equivalent to C252) • LC54 (Operation equivalent to C254) 																		
CH2	<ul style="list-style-type: none"> • LC36 (Operation equivalent to C236) 																		
CH3	<ul style="list-style-type: none"> • LC37 (Operation equivalent to C237) • LC42 (Operation equivalent to C242) • LC45 (Operation equivalent to C245) 																		
CH4	<ul style="list-style-type: none"> • LC38 (Operation equivalent to C238) • LC48 (Operation equivalent to C248) • LC50 (Operation equivalent to C250) • LC53 (Operation equivalent to C253) • LC55 (Operation equivalent to C255) • LC48 (Operation equivalent to C248(OP)) • LC53 (Operation equivalent to C253(OP)) 																		
CH5	<ul style="list-style-type: none"> • LC39 (Operation equivalent to C239) • LC43 (Operation equivalent to C243) 																		
CH6	<ul style="list-style-type: none"> • LC40 (Operation equivalent to C240) 																		
CH7	<ul style="list-style-type: none"> • LC44 (Operation equivalent to C244(OP)) • LC54 (Operation equivalent to C254(OP)) 																		
CH8	<ul style="list-style-type: none"> • LC45 (Operation equivalent to C245) 																		
Operation Mode	Not available for FX3-compatible high-speed counters.	—	—																
Pulse Input Mode	Set pulse input mode.	<ul style="list-style-type: none"> • 2 Phase 1 Multiple • 2 Phase 4 Multiple 	—																

Item	Description	Setting range	Default
Preset Input Enable/Disable	Not available for FX3-compatible high-speed counters	—	—
Input Logic	Sets preset input logic when preset input is enabled.	<ul style="list-style-type: none"> • Positive Logic • Negative Logic 	—
Preset Value	Sets preset input logic when preset input is enabled.	—	—
Input Comparison Enable/Disable	Sets whether to "enable" or "disable" input comparison when preset input is enabled.	<ul style="list-style-type: none"> • Disable • Enable 	—
Control Switch	Sets preset execution timing when preset input is enabled.	<ul style="list-style-type: none"> • Rising • Falling • Rising + Falling Edge • Always During Input ON 	—
Enable Input Enable/Disable	Not available for FX3-compatible high-speed counters	—	—
Input Logic			
Ring Length Enable/Disable			
Ring Length			
Measurement Unit Time			
Pulses No. of per Rotation			



Parameters are enabled when the CPU module is powered ON or after a reset.

Special relay list

A list of special relays used for high-speed counters is provided below.

Only the special relay corresponding to the LC device used as the high-speed counter operates when the FX3 compatible high-speed counter function is valid.

The special relay/special registers other than those described in the list below operates in the same manner as when the FX3 compatible high-speed counter function is not valid.

Special relay	Function	Operation		Default	R/W
		ON	OFF		
SM8246	LC46 counting direction monitoring	Down-counting	Up-counting	OFF	R
SM8247	LC47 counting direction monitoring	Down-counting	Up-counting	OFF	R
SM8248	LC48 counting direction monitoring	Down-counting	Up-counting	OFF	R
SM8249	LC49 counting direction monitoring	Down-counting	Up-counting	OFF	R
SM8250	LC50 counting direction monitoring	Down-counting	Up-counting	OFF	R
SM8251	LC51 counting direction monitoring	Down-counting	Up-counting	OFF	R
SM8252	LC52 counting direction monitoring	Down-counting	Up-counting	OFF	R
SM8253	LC53 counting direction monitoring	Down-counting	Up-counting	OFF	R
SM8254	LC54 counting direction monitoring	Down-counting	Up-counting	OFF	R
SM8255	LC55 counting direction monitoring	Down-counting	Up-counting	OFF	R

LC□ count direction monitor

This is the device to monitor the directions of the counters from LC35 to LC55 when the FX3 compatible high-speed counter is used.

■Operation Description

The content of the operation when ON and when OFF is as follows.

Operation when ON	Operation when OFF
High-speed counter counting in direction whereby current value is reduced (Down-counting)	High-speed counter counting in direction whereby current value is increased (Up-counting)

■Update timing

The timing of device update is as follows.

ON	OFF
Down-counting (This is updated with the END processing. When the FX3 compatible high-speed counter function is valid, the updating is made also when UDCNTF instruction is executed ON.)	<ul style="list-style-type: none"> Up-counting (This is updated with the END processing. When the FX3 compatible high-speed counter function is valid, the updating is made also when UDCNTF instruction is executed ON.) Power ON, reset STOP/PAUSE→RUN

Special relays/LC devices capable of high-speed transfers with the HCMOV instruction

Shown below are the special relay/LC device that can read and write the latest value with the HCMOV instruction when the FX3 compatible high-speed counter function is valid. When special relays and special registers are specified for (s) and (d) instructions other than the HCMOV instruction, the operation is the same as one compatible with the MOV instruction.

The same operation as when the FX3 compatible high-speed counter is not valid is made for the special relay/special register capable of high-speed transfers with the HCMOV instruction other than those described in the list below.

Special relay

○: High-speed transfer capable (special relay is immediately updated)

△: Normal transfer capable (special relay is updated in END processing)

×: Transfer not possible (read-only)

Special relay	Function	Compatible with HCMOV instruction		Compatible with MOV instruction	
		(s)	(d)	(s)	(d)
SM8246	LC46 counting direction monitoring	○	×	△	×
SM8247	LC47 counting direction monitoring	○	×	△	×
SM8248	LC48 counting direction monitoring	○	×	△	×
SM8249	LC49 counting direction monitoring	○	×	△	×
SM8250	LC50 counting direction monitoring	○	×	△	×
SM8251	LC51 counting direction monitoring	○	×	△	×
SM8252	LC52 counting direction monitoring	○	×	△	×
SM8253	LC53 counting direction monitoring	○	×	△	×
SM8254	LC54 counting direction monitoring	○	×	△	×
SM8255	LC55 counting direction monitoring	○	×	△	×

LC device

- : High-speed transfer capable (special relay is immediately updated)
 △: Normal transfer capable (special relay is updated in END processing)
 ×: Transfer not possible (read-only)

LC device	Function	Compatible with HCMOV instruction		Compatible with MOV instruction	
		(s)	(d)	(s)	(d)
LC35	High-speed counter current value (CH1)	○	○	△	×
LC36	High-speed counter current value (CH2)	○	○	△	×
LC37	High-speed counter current value (CH3)	○	○	△	×
LC38	High-speed counter current value (CH4)	○	○	△	×
LC39	High-speed counter current value (CH5)	○	○	△	×
LC40	High-speed counter current value (CH6)	○	○	△	×
LC41	High-speed counter current value (CH1)	○	○	△	×
LC42	High-speed counter current value (CH3)	○	○	△	×
LC43	High-speed counter current value (CH5)	○	○	△	×
LC44	High-speed counter current value (CH1)/High-speed counter current value (CH7)	○	○	△	×
LC45	High-speed counter current value (CH3)/High-speed counter current value (CH8)	○	○	△	×
LC46	High-speed counter current value (CH1)	○	○	△	×
LC47	High-speed counter current value (CH1)	○	○	△	×
LC48	High-speed counter current value (CH4)	○	○	△	×
LC49	High-speed counter current value (CH1)	○	○	△	×
LC50	High-speed counter current value (CH4)	○	○	△	×
LC51	High-speed counter current value (CH1)	○	○	△	×
LC52	High-speed counter current value (CH1)	○	○	△	×
LC53	High-speed counter current value (CH4)	○	○	△	×
LC54	High-speed counter current value (CH1)/High-speed counter current value (CH7)	○	○	△	×
LC55	High-speed counter current value (CH4)	○	○	△	×

Precautions when using FX3-compatible high-speed counters

Shown below are the precautions for using the FX3 compatible high-speed counter. For any other precautions, see the precautions for each function.

- When the FX3 compatible function is valid, it is possible to specify the LC device in (s1) of the HSCS instruction/HSCR instruction and (s) of the HSZ instruction. If an LC device that is not used as high-speed counter is specified, an error occurs, and the HSCS instruction, the HSCR instruction, and the HSZ instruction do not operate.
- Set up the table with the CH number of the counter if the table number of the high-speed comparison table/the multi-point output high-speed comparison table needs to be specified.
- To clear the current value of the LC device, use the DHCMOV instruction or the RST instruction to clear it.
- Use the latch setting to use LC35 to LC55 with the high-speed counter of the FX3 compatible function.
- The reset coil of the LC device is cleared when the power is set from OFF to ON.

19.3 Pulse Width Measurement Function

This section describes the pulse width measurement function.

Pulse width measurement function overview

The CPU module has a built-in pulse width measurement function and it is capable of measuring the pulse width/period of a maximum of 4 channels. The pulse width/period measurement function stores the values of 0.5 μ s ring counters at the input signal rising edge and falling edge to special data registers. This function also stores the difference in the counter values (pulse width) between the rising edge and the falling edge or stores the difference in the counter values (cycle) between the previous rising edge and the current rising edge to special data registers in units of 0.5 μ s.

For the pulse width measurement function, input channel assignments, logical switch, and measurement mode settings are configured with parameters, and measurements are started/stopped using the HIOEN instruction.



To use the pulse width measurement function, parameter settings and the HIOEN instruction are always required.

Pulse width measurement specifications

This section describes the pulse width measurement function specifications.

Pulse input signals

Pulse width measurements can be used for a maximum of 4 channels.

Select from X0 to X7 for each channel, with parameter settings.

■Measurement frequencies

The table below shows the measurement frequencies.

FX5U-32M□, FX5UC-32M□	FX5U-64M□, FX5U-80M□	Measurement frequencies
X0 to X5	X0 to X7	200 KHz
X6 to X17	X10 to X17	10 KHz

■Measurement precision

The table below shows the measurement precision.

Item	Description	
Possible measurement range	Cycle	5 μ s
	Pulse width	5 μ s
Maximum measurable signal width	1073s741ms823 μ s	
Resolution	0.5 μ s	

Pulse measurements

The pulse width and period are stored in special devices by the END instruction. (☞ Page 177 List of special relays/special registers)

Pulse width maximum value and minimum value

The maximum value and minimum value of the pulse width from the start of measurements are stored in special devices.

(☞ Page 177 List of special relays/special registers)

Period maximum value and minimum value

The maximum value and minimum value of the period from the start of measurements are stored in special devices.

(☞ Page 177 List of special relays/special registers)

Switching positive logic/negative logic

The pulse input logic can be switched.

Positive logic or negative logic can be set for each channel with parameter settings.

■ Operation for positive logic

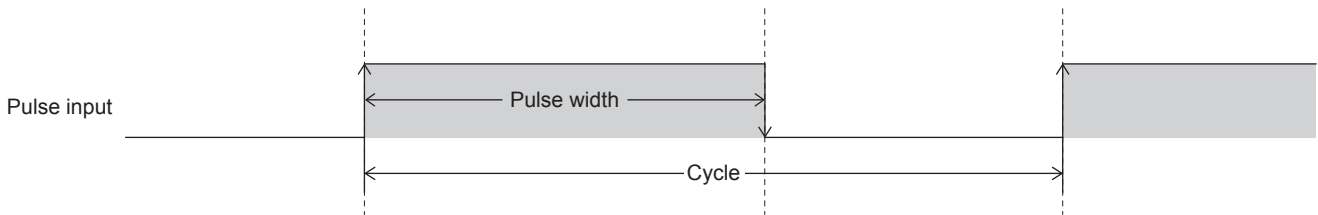

■ Operation for negative logic

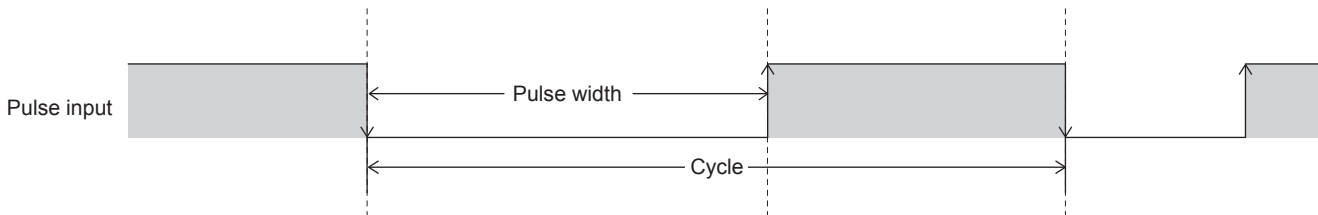

19

Continuous measurement/one-time measurement mode

The pulse width measurement mode can be set.

The table below shows the measurement modes for pulse width measurements.

Mode	Description
1 time measurement mode	Measures the pulse width and period only once from the start of the measurement.
Always measurement mode	Constantly measures the pulse width and period.

Point

The measurement mode can be changed during pulse measurements by using a special relay. (☞ Page 177 List of special relays/special registers)

Signal delay time measurement

In a user program, the delay time between signals can be calculated from the rising or falling ring counters of 2 inputs.

(☞ Page 183 Examples of program)

Pulse measurement function execution procedure

The pulse measurement function execution procedure is shown below.

1. Check the pulse measurement specifications.

Check the specifications such as the measurement frequency of pulse measurements. (☞ Page 174 Pulse width measurement specifications)

2. Connect the CPU module to the external device.

For details on wiring to external devices, refer to the following manual

📖 MELSEC iQ-F FX5U User's Manual (Hardware)

📖 MELSEC iQ-F FX5UC User's Manual (Hardware)

3. Set the parameters.

Configure the parameters such as the pulse measurement channel settings. (☞ Page 176 Pulse width measurement parameters)

4. Create the program.

Create the program for using pulse measurements.

5. Run the program.

Pulse width measurement parameters

This section explains the parameters for pulse width measurement.

Set the parameters for pulse width measurement in GX Works3.

Outline of parameters

Parameters for pulse width measurement are input allocation, logical switch, measurement modes and input response time.

Parameter setting

The following explains how to set the parameters for pulse width measurement.

For input response time, refer to  Page 191 General-purpose Input Functions.

 Navigation window ⇒ [Parameter] ⇒ [FX5UCPU] ⇒ [Module Parameter] ⇒ [High Speed I/O] ⇒ "Input Function" ⇒ "Pulse Width Measurement" ⇒ "Detail Setting"

Window

Item	CH1	CH2	CH3	CH4
Use Pulse Width Measurement	Set whether to use pulse width measurement or not.			
Use/Not Use	Disable	Disable	Disable	Disable
Input Signal	Set input signal.			
Input Signal	X0	X0	X0	X0
Logical Switch	Set logical switch.			
Logical Switch	Positive Logic	Positive Logic	Positive Logic	Positive Logic
Measurement Mode	Set measurement mode.			
Measurement Mode	Always Measurement Mode	Always Measurement Mode	Always Measurement Mode	Always Measurement Mode

Displayed items

Item	Description	Setting range	Default
Use Pulse Width Measurement	Set whether to use pulse width measurement or not.	<ul style="list-style-type: none"> Disable Enable 	Disable
Input Signal	Set input signal.	X0 to X7	—
Logical Switch	Set logical switch.	<ul style="list-style-type: none"> Positive Logic Negative Logic 	—
Measurement Mode	Set measurement mode.	<ul style="list-style-type: none"> Always Measurement Mode 1 Time Measurement Mode 	—

Point

The items specified in the parameters are stored in special devices when the CPU module is set from STOP to RUN.

List of special relays/special registers

The list of special relays/special registers used in pulse width measurement is shown below.

R/W: Read or write (Note, however, that only writing is allowed for the HCMOV instruction.)

R: Read only

Special relays/ special registers	Function	Description	Default	R/W
SM5020	CH1 pulse width measurement status flag	The measurement in progress/measurement stopped status of pulse width measurement on the target channel can be checked by these flags. OFF: Measurement stopped ON: Measurement in progress	OFF	R
SM5021	CH2 pulse width measurement status flag			
SM5022	CH3 pulse width measurement status flag			
SM5023	CH4 pulse width measurement status flag			
SM5036	CH1 rising edge flag	These flags turn ON at the end of the 1st period measurement on the target channel. (They remain ON during measurement in the always measurement mode.)	OFF	R
SM5037	CH2 rising edge flag			
SM5038	CH3 rising edge flag			
SM5039	CH4 rising edge flag			
SM5052	CH1 falling edge flag	These flags turn ON at the end of the 1st pulse width measurement on the target channel. (They remain ON during measurement in the always measurement mode.)	OFF	R
SM5053	CH2 falling edge flag			
SM5054	CH3 falling edge flag			
SM5055	CH4 falling edge flag			
SM5068	CH1 measurement mode	The measurement mode of the target channel can be checked by these flags. (To change the measurement mode during operation, use this special relay.) OFF: Always measurement mode ON: 1 time measurement mode	ON	R/W
SM5069	CH2 measurement mode			
SM5070	CH3 measurement mode			
SM5071	CH4 measurement mode			
SD5021, SD5020	CH1 rising edge ring counter value	The ring counter value when the rising edge is detected is stored.	00000000H	R/W
SD5023, SD5022	CH1 falling edge ring counter value	The ring counter value when the falling edge is detected is stored.	00000000H	R/W
SD5025, SD5024	CH1 pulse width latest value	The latest value of the pulse width is stored.	00000000H	R/W
SD5027, SD5026	CH1 pulse width maximum value	The maximum value of the pulse width is stored.	00000000H	R/W
SD5029, SD5028	CH1 pulse width minimum value	The minimum value of the pulse width is stored.	FFFFFFFFH	R/W
SD5031, SD5030	CH1 period latest value	The latest value of the period is stored.	00000000H	R/W
SD5033, SD5032	CH1 period maximum value	The maximum value of the period is stored.	00000000H	R/W
SD5035, SD5034	CH1 period minimum value	The minimum value of the period is stored.	FFFFFFFFH	R/W
SD5041, SD5040	CH2 rising edge ring counter value	The ring counter value when the rising edge is detected is stored.	00000000H	R/W
SD5043, SD5042	CH2 falling edge ring counter value	The ring counter value when the falling edge is detected is stored.	00000000H	R/W
SD5045, SD5044	CH2 pulse width latest value	The latest value of the pulse width is stored.	00000000H	R/W
SD5047, SD5046	CH2 pulse width maximum value	The maximum value of the pulse width is stored.	00000000H	R/W
SD5049, SD5048	CH2 pulse width minimum value	The minimum value of the pulse width is stored.	FFFFFFFFH	R/W
SD5051, SD5050	CH2 period latest value	The latest value of the period is stored.	00000000H	R/W
SD5053, SD5052	CH2 period maximum value	The maximum value of the period is stored.	00000000H	R/W
SD5055, SD5054	CH2 period minimum value	The minimum value of the period is stored.	FFFFFFFFH	R/W
SD5061, SD5060	CH3 rising edge ring counter value	The ring counter value when the rising edge is detected is stored.	00000000H	R/W
SD5063, SD5062	CH3 falling edge ring counter value	The ring counter value when the falling edge is detected is stored.	00000000H	R/W
SD5065, SD5064	CH3 pulse width latest value	The latest value of the pulse width is stored.	00000000H	R/W
SD5067, SD5066	CH3 pulse width maximum value	The maximum value of the pulse width is stored.	00000000H	R/W
SD5069, SD5068	CH3 pulse width minimum value	The minimum value of the pulse width is stored.	FFFFFFFFH	R/W
SD5071, SD5070	CH3 period latest value	The latest value of the period is stored.	00000000H	R/W
SD5073, SD5072	CH3 period maximum value	The maximum value of the period is stored.	00000000H	R/W
SD5075, SD5074	CH3 period minimum value	The minimum value of the period is stored.	FFFFFFFFH	R/W
SD5081, SD5080	CH4 rising edge ring counter value	The ring counter value when the rising edge is detected is stored.	00000000H	R/W
SD5083, SD5082	CH4 falling edge ring counter value	The ring counter value when the falling edge is detected is stored.	00000000H	R/W
SD5085, SD5084	CH4 pulse width latest value	The latest value of the pulse width is stored.	00000000H	R/W

Special relays/ special registers	Function	Description	Default	R/W
SD5087, SD5086	CH4 pulse width maximum value	The maximum value of the pulse width is stored.	00000000H	R/W
SD5089, SD5088	CH4 pulse width minimum value	The minimum value of the pulse width is stored.	FFFFFFFFH	R/W
SD5091, SD5090	CH4 period latest value	The latest value of the period is stored.	00000000H	R/W
SD5093, SD5092	CH4 period maximum value	The maximum value of the period is stored.	00000000H	R/W
SD5095, SD5094	CH4 period minimum value	The minimum value of the period is stored.	FFFFFFFFH	R/W

Details of special relays/special registers

Details of special relays/special registers used in pulse width measurement are explained below.

Pulse width measurement status flag

This flag is a device for monitoring the measurement in progress/measurement stopped status of pulse width measurement.

■Corresponding devices

The device numbers corresponding to each channel are as follows.

CH1	CH2	CH3	CH4
SM5020	SM5021	SM5022	SM5023

■Update timing

This device turns ON when the HIOEN instruction is executed. It turns OFF at the END instruction when the measurement mode is the 1 time measurement mode.

■Clear timing

The timing when the device is cleared is as follows.

- Power OFF→ON
- Reset
- STOP/PAUSE→RUN
- RUN→STOP/PAUSE
- When measurement is stopped by the HIOEN instruction

Rising edge flag

This flag turns ON at the end of the 1st period measurement. During measurement in the always measurement mode, it stays ON.

■Corresponding devices

The device numbers corresponding to each channel are as follows.

CH1	CH2	CH3	CH4
SM5036	SM5037	SM5038	SM5039

■Update timing

Devices are updated by the END instruction.

■Clear timing

The timing when the device is cleared is as follows.

- Power OFF→ON
- Reset
- STOP/PAUSE→RUN
- When measurement is started by the HIOEN instruction



When the HCMOV instruction is used, the latest value can be read.

Falling edge flag

This flag turns ON at the end of the 1st pulse width measurement. During measurement in the always measurement mode, it stays ON.

■Corresponding devices

The device numbers corresponding to each channel are as follows.

CH1	CH2	CH3	CH4
SM5052	SM5053	SM5054	SM5055

■Update timing

Devices are updated by the END instruction.

■Clear timing

The timing when the device is cleared is as follows.

- Power OFF→ON
- Reset
- STOP/PAUSE→RUN
- When measurement is started by the HIOEN instruction



When the HCMOV instruction is used, the latest value can be read.

Measurement mode

The measurement mode can be checked. The measurement mode can also be changed during operation by turning special relays ON/OFF.

OFF: Always measurement mode

ON: 1 time measurement mode



The measurement mode can be changed only by the HCMOV instruction.

■Corresponding devices

The device numbers corresponding to each channel are as follows.

CH1	CH2	CH3	CH4
SM5058	SM5059	SM5060	SM5061

■Update timing

After the measurement mode is changed, devices are updated by the next END instruction.

When the HCMOV instruction is executed, devices are updated immediately.

■Clear timing

The timing when the device is cleared is as follows.

- Power OFF→ON
- Reset
- STOP/PAUSE→RUN
- When the measurement mode is changed by the HCMOV instruction

Rising edge ring counter value

The ring counter value when the rising edge is detected is stored.



Ring counter values can be changed only by the HCMOV instruction.

■Corresponding devices

The device numbers corresponding to each channel are as follows.

CH1	CH2	CH3	CH4
SD5021, SD5020	SD5041, SD5040	SD5061, SD5060	SD5081, SD5080

■Update timing

Devices are updated by the END instruction.

When the HCMOV instruction is executed, devices are updated immediately.

■Clear timing

The timing when the device is cleared is as follows.

- Power OFF→ON
- Reset
- STOP/PAUSE→RUN
- When "0" is written by the HCMOV instruction

Falling edge ring counter value

The ring counter value when the falling edge is detected is stored.



Ring counter values can be changed only by the HCMOV instruction.

■Corresponding devices

The device numbers corresponding to each channel are as follows.

CH1	CH2	CH3	CH4
SD5023, SD5022	SD5043, SD5042	SD5063, SD5062	SD5083, SD5082

■Update timing, clear timing

Same as the rising edge ring counter value (Page 180 Rising edge ring counter value)

Pulse width latest value

The latest value of the pulse width is stored.



- When logic switching is set to positive logic, the difference from the rising edge up to the falling edge.
- When logic switching is set to negative logic, the difference from the falling edge up to the rising edge.
- The latest value of the pulse width can be changed only by the HCMOV instruction.

■Corresponding devices

The device numbers corresponding to each channel are as follows.

CH1	CH2	CH3	CH4
SD5025, SD5024	SD5045, SD5044	SD5065, SD5064	SD5085, SD5084

■Update timing, clear timing

Same as the rising edge ring counter value (Page 180 Rising edge ring counter value)

Pulse width maximum value

The maximum value of the pulse width is stored.

Point

- When logic switching is set to positive logic, the difference from the rising edge up to the falling edge.
- When logic switching is set to negative logic, the difference from the falling edge up to the rising edge.
- The maximum value of the pulse width can be changed only by the HCMOV instruction.

■Corresponding devices

The device numbers corresponding to each channel are as follows.

CH1	CH2	CH3	CH4
SD5027, SD5026	SD5047, SD5046	SD5067, SD5066	SD5087, SD5086

■Update timing, clear timing

Same as the rising edge ring counter value ( Page 180 Rising edge ring counter value)

Pulse width minimum value

The minimum value of the pulse width is stored.

Point

- When logic switching is set to positive logic, the difference from the rising edge up to the falling edge.
- When logic switching is set to negative logic, the difference from the falling edge up to the rising edge.
- The minimum value of the pulse width can be changed only by the HCMOV instruction.

■Corresponding devices

The device numbers corresponding to each channel are as follows.

CH1	CH2	CH3	CH4
SD5029, SD5028	SD5049, SD5048	SD5069, SD5068	SD5089, SD5088

■Update timing, clear timing

Same as the rising edge ring counter value ( Page 180 Rising edge ring counter value)

Period latest value

The latest value of the period is stored.

Point

- When logic switching is set to positive logic, the difference from the previous rising edge up to the latest rising edge.
- When logic switching is set to negative logic, the difference from the previous falling edge up to the latest falling edge.
- The latest value of the period can be changed only by the HCMOV instruction.

■Corresponding devices

The device numbers corresponding to each channel are as follows.

CH1	CH2	CH3	CH4
SD5031, SD5030	SD5051, SD5050	SD5071, SD5070	SD5091, SD5090

■Update timing, clear timing

Same as the rising edge ring counter value ( Page 180 Rising edge ring counter value)

Period maximum value

The maximum value of the period is stored.

Point

- When logic switching is set to positive logic, the difference from rising edge to rising edge.
- When logic switching is set to negative logic, the difference from falling edge to falling edge.
- The maximum value of the period can be changed only by the HCMOV instruction.

■Corresponding devices

The device numbers corresponding to each channel are as follows.

CH1	CH2	CH3	CH4
SD5033, SD5032	SD5053, SD5052	SD5073, SD5072	SD5093, SD5092

■Update timing, clear timing

Same as the rising edge ring counter value ( Page 180 Rising edge ring counter value)

Period minimum value

The minimum value of the period is stored.

Point

- When logic switching is set to positive logic, the difference from rising edge to rising edge.
- When logic switching is set to negative logic, the difference from falling edge to falling edge.
- The minimum value of the period can be changed only by the HCMOV instruction.

■Corresponding devices

The device numbers corresponding to each channel are as follows.

CH1	CH2	CH3	CH4
SD5035, SD5034	SD5055, SD5054	SD5075, SD5074	SD5095, SD5094

■Update timing, clear timing

Same as the rising edge ring counter value ( Page 180 Rising edge ring counter value)

Cautions when using the pulse width measurement function

- When the HCMOV instruction is used, the latest ring counter value, pulse width, cycle, maximum value, and minimum value can be obtained.
- The measurement mode can be changed using the special relays. Note, however, that the measurement mode cannot be changed during pulse width measurement. To change the measurement mode, stop pulse width measurement, change the measurement mode and then resume measurement.
- Pulse measurement is possible only while in RUN status. Pulse width measurement is stopped by RUN→PAUSE and RUN→STOP.

Examples of program

An example of a program using the pulse width measurement function is explained below.

Outline of operation

A program for measuring the delay time between the rising edges of input signals X1 and X2 on the CPU module is explained below.

Parameter setting

This program assumes that parameters are set as follows.

Input signals X1 and X2 are assigned to CH1 (X1) and CH2 (X2) by parameters. CH3 and CH4 need not be set.

Item	CH to be used	
	CH1	CH2
Input signal	X1	X2
Input logic switching	Positive logic	Positive logic
Measurement mode	Always measurement mode	Always measurement mode

Program

An operation diagram and program are shown below.

Operation diagram

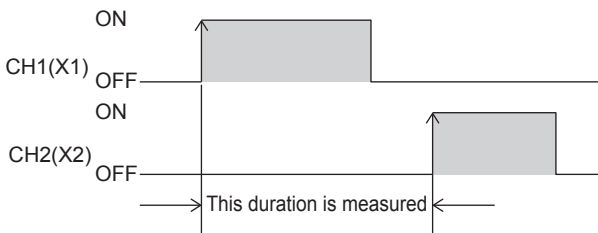

Program

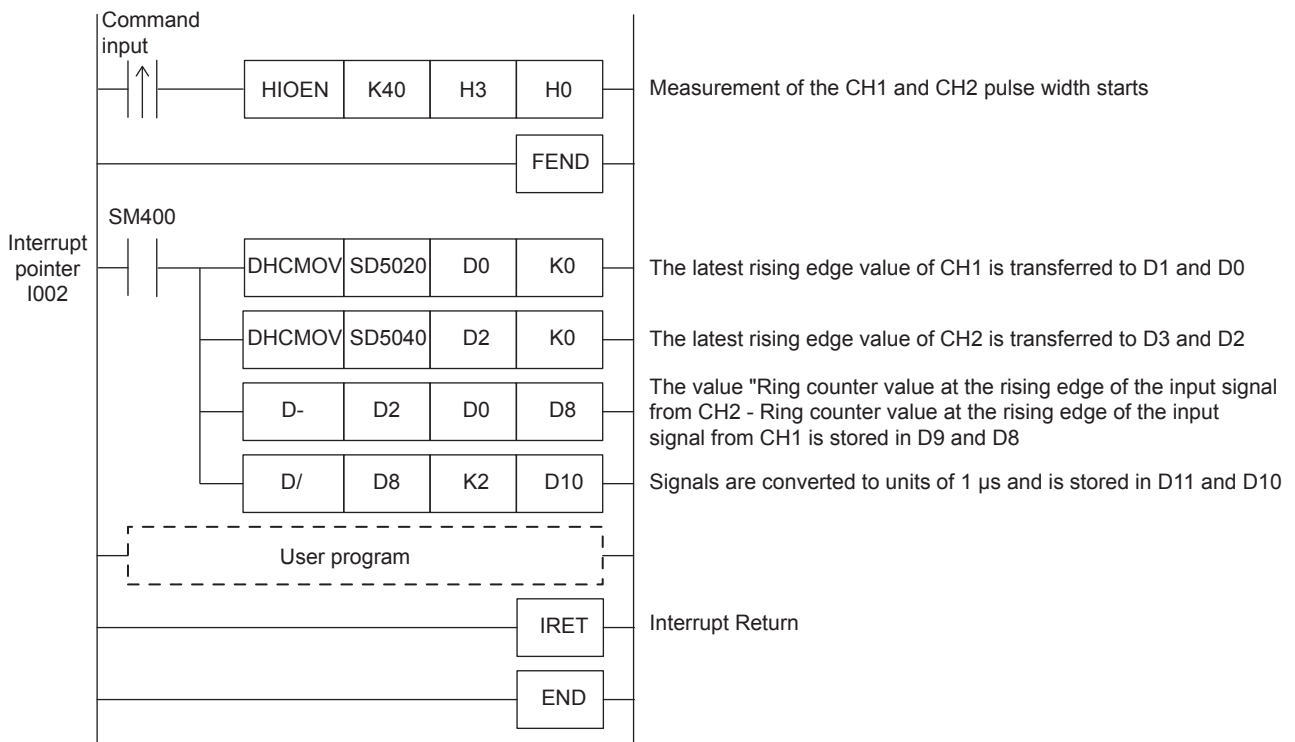

19.4 Pulse Catch Function

This section explains the pulse catch function.

Outline of pulse catch function

The CPU module has a built-in pulse catch function which enables pulse signals that are incompletely sampled in regular input processing to be caught. Inputs X0 to X17 on the CPU module can be used on up to eight channels.

To use the pulse catch function, pulse catch setting and the input response time must be set with parameters.

An FX3-compatible pulse catch function is also mounted on the CPU module, For details of functions, refer to [Page 188](#) FX3-Compatible Pulse Catch Function.

Point

The pulse catch function and FX3-compatible pulse catch function can be used simultaneously.

Specifications of pulse catch function

The specifications of the pulse catch function are explained below.

Performance specifications

Pulse catches can be used on inputs X0 to X17.

Input response time

Input response times are shown below.

FX5U-32M□, FX5UC-32M□	FX5U-64M□, FX5U-80M□	Input response time
X0 to X5	X0 to X7	5 μs
X6 to X17	X10 to X17	100 μs

Detectable pulse width

Pulse widths that satisfy the following condition can be detected.

Pulse input ON width > input response time

Point

Pulses cannot be detected normally if the above condition is not satisfied. Set the input response time so that the above condition is satisfied.

Pulse catch function execution procedure

The procedure for executing the pulse catch function is explained below.

1. Check the pulse catch specifications.

Check specifications such as the input response time of the pulse catch. ([Page 184](#) Specifications of pulse catch function)

2. Connect the CPU module to the external device.

For details on wiring to external devices, refer to the following manual

[MELSEC iQ-F FX5U User's Manual \(Hardware\)](#)

[MELSEC iQ-F FX5UC User's Manual \(Hardware\)](#)

3. Set the parameters.

Set the pulse catch setting and other parameters. ([Page 185](#) Pulse catch parameters)

4. Create the program.

5. Run the program.

Pulse catch parameters

This section explains the pulse catch parameters.
Set the pulse catch parameters in GX Works3.

Outline of parameters

Pulse catch parameters are pulse catch setting and input response time.

Parameter setting

This section explains how to set pulse catch parameters.

For input response time, refer to Page 191 General-purpose Input Functions.

Navigation window ⇒ [Parameter] ⇒ [FX5UCPU] ⇒ [Module Parameter] ⇒ [High Speed I/O] ⇒ "Input Function" ⇒ "General/Interrupt/Pulse Catch" ⇒ "Detail Setting"

Window

Item	Setting
General/Interrupt/Pulse Catch Setting	Set the general/interrupt/pulse catch of input terminal.
X0	Interrupt (Rising) + Pulse Catch
X1	General-purpose Input
X2	General-purpose Input
X3	General-purpose Input
X4	General-purpose Input
X5	General-purpose Input
X6	General-purpose Input
X7	General-purpose Input
X10	General-purpose Input
X11	General-purpose Input
X12	General-purpose Input
X13	General-purpose Input
X14	General-purpose Input
X15	General-purpose Input
X16	General-purpose Input
X17	General-purpose Input

Displayed items

Item	Description	Setting range	Default
General/Interrupt/Pulse Catch	Set the function to be used. Set to "Interrupt (Rising) + Pulse Catch".	<ul style="list-style-type: none"> General-purpose Input Interrupt (Rising) Interrupt (Falling) Interrupt (Rising + Falling) Interrupt (Rising) + Pulse Catch 	General-purpose Input

Point

Parameters are enabled when the CPU module is powered ON or after a reset.

Operation of pulse catch function

Operation of the pulse catch function is explained below.

Basic operation of pulse catch function

The corresponding input device is turned ON for the duration of the scan following the scan where the pulse signal is detected. The input device is turned OFF at the END instruction.

■ Operation when input signal is used as pulse catch function

The rising edge of the external input signal (X0) is detected, and the input device is turned ON only during the following scan.

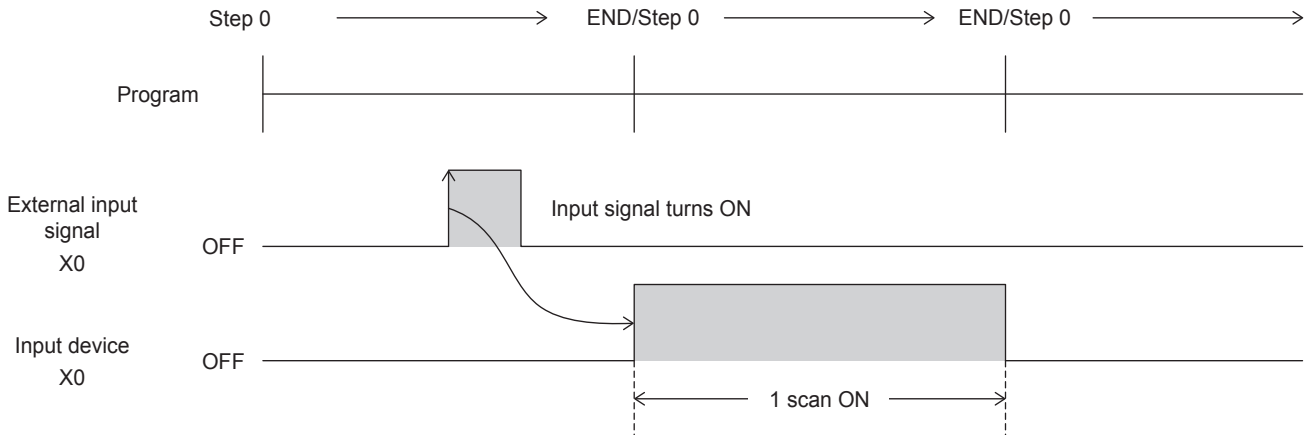

■ Operation when multiple pulses are detected within one scan

The second pulse onwards is ignored. Input pulse signals at intervals of one scan or longer.

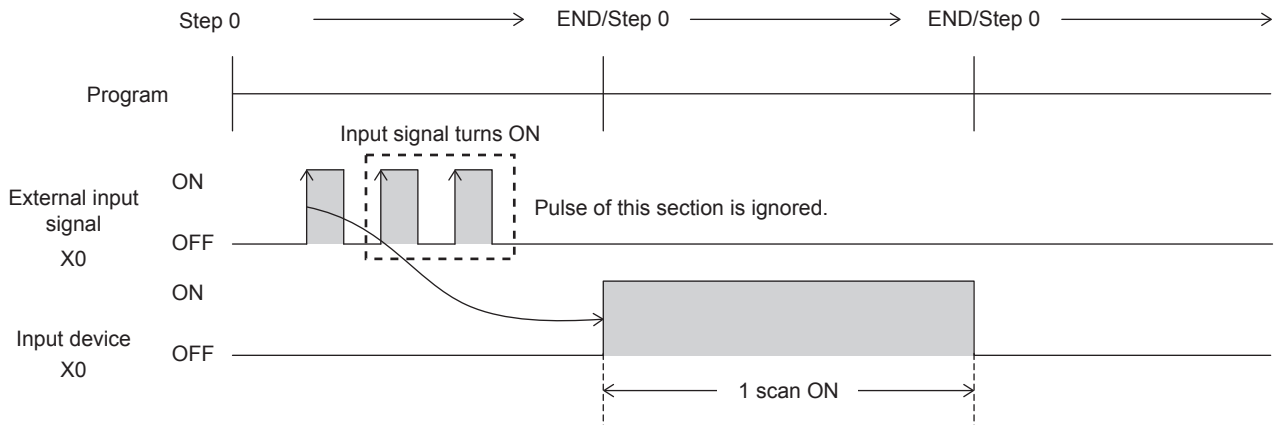

■ Operation when the same pulse is detected for two scans or more

The input device is turned ON for the detected number of scans. Input pulse signals at intervals of one scan or longer.

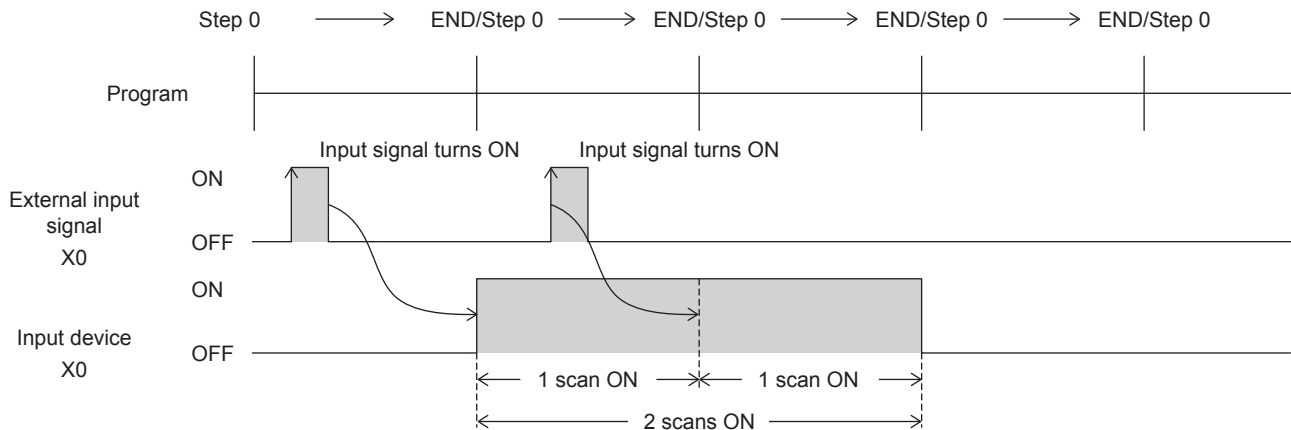

■ Operation when a pulse having an ON width of two scans or more is input

The input device is turned ON for one scan only.

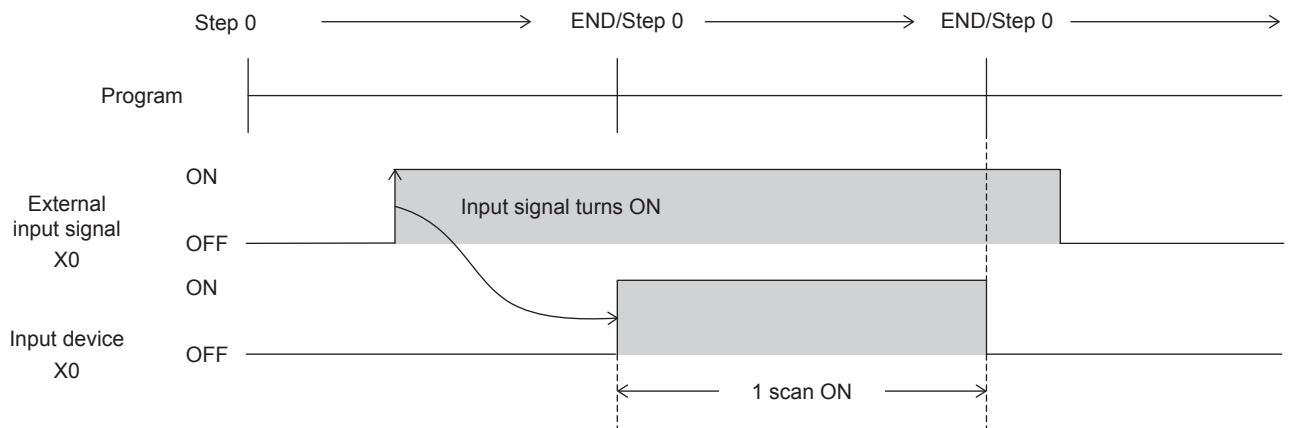

Cautions when using the pulse catch function

- The pulse catch function operates only when "Interrupt (Rising) + Pulse Catch" is set with parameters.
- The pulse catch function can be used on inputs X0 to X17 on the CPU module. Note, however, that these inputs can be used on up to eight channels.

Do not perform the following on inputs (X0 to X17) for which the pulse catch function is selected. Doing so results in the input device not turning ON normally in one scan after the pulse is detected.

- Use of direct device (DX)
- Execution of input refreshing during execution of the REF, RFS instructions, etc.

19.5 FX3-Compatible Pulse Catch Function

This section explains the FX3-compatible pulse catch function.

Outline of FX3-compatible pulse catch function

An FX3-compatible pulse catch function is mounted on the CPU module,

When the input signal X0 to X7 turns OFF→ON, a special relay (SM8170 to SM8177) is immediately set to ON by interrupt processing. Use of these special relays in a normal sequence program enables pulse signals that are incompletely sampled in regular input processing to be caught.

To use the FX3-compatible pulse catch function, pulse catch setting and the input response time must be set with parameters. Functions equivalent to the MELSEC Q/L series pulse catch function are also mounted. For details of functions, refer to  Page 184 Pulse Catch Function.

Point

The pulse catch function and FX3-compatible pulse catch function can be used simultaneously.

Specifications of FX3-compatible pulse catch function

This specifications of the FX3-compatible pulse catch function are explained below.

Performance specifications

FX3-compatible pulse catches can be used on inputs X0 to X7.

■Input response time

Input response times are shown below.

FX5U-32M□, FX5UC-32M□	FX5U-64M□, FX5U-80M□	Input response time
X0 to X5	X0 to X7	5 μs
X6 to X7		100 μs

■Assignment of input numbers and special relays

The assignments of input numbers and special relays are explained below.

Input number	Corresponding special relay
X0	SM8170
X1	SM8171
X2	SM8172
X3	SM8173
X4	SM8174
X5	SM8175
X6	SM8176
X7	SM8177

FX3-compatible pulse catch function execution procedure

The procedure for executing the FX3-compatible pulse catch function is explained below.

1. Check the FX3-compatible pulse catch specifications.

Check specifications such as the input response time and corresponding special relay of the FX3-compatible pulse catch. (☞ Page 188 Specifications of FX3-compatible pulse catch function)

2. Connect the CPU module to the external device.

For details on wiring to external devices, refer to the following manual

📖 MELSEC iQ-F FX5U User's Manual (Hardware)

📖 MELSEC iQ-F FX5UC User's Manual (Hardware)

3. Set the parameters.

Set the pulse catch setting and other parameters. (☞ Page 189 FX3-compatible pulse catch parameters)

4. Create the program.

Create the program for using pulse catch.

5. Run the program.

FX3-compatible pulse catch parameters

This section explains the FX3-compatible pulse catch parameters.

Set the FX3-compatible pulse catch parameters in GX Works3.

Outline of parameters

FX3-compatible pulse catch parameters are pulse catch setting and input response time.

Parameter setting

This section explains how to set FX3-compatible pulse catch parameters.

For input response time, refer to ☞ Page 191 General-purpose Input Functions.

🖱️ Navigation window ⇒ [Parameter] ⇒ [FX5UCPU] ⇒ [Module Parameter] ⇒ [High Speed I/O] ⇒ "Input Function" ⇒ "General/Interrupt/Pulse Catch" ⇒ "Detail Setting"

Window

Item	Setting
General/Interrupt/Pulse Catch Setting	Set the general/interrupt/pulse catch of input terminal.
X0	Interrupt (Rising) 
X1	General-purpose Input
X2	General-purpose Input
X3	General-purpose Input
X4	General-purpose Input
X5	General-purpose Input
X6	General-purpose Input
X7	General-purpose Input
X10	General-purpose Input
X11	General-purpose Input
X12	General-purpose Input
X13	General-purpose Input
X14	General-purpose Input
X15	General-purpose Input
X16	General-purpose Input
X17	General-purpose Input

Displayed items

Item	Description	Setting range	Default
General/Interrupt/Pulse Catch Setting	Set the function to be used. Set to "Interrupt (Rising)" or "Interrupt (Rising) + Pulse Catch".	<ul style="list-style-type: none"> • General-purpose Input • Interrupt (Rising) • Interrupt (Falling) • Interrupt (Rising + Falling) • Interrupt (Rising) + Pulse Catch 	General-purpose Input

Point

Parameters are enabled when the CPU module is powered ON or after a reset.

Operation of FX3-compatible pulse catch function

Operation of the FX3-compatible pulse catch function is explained below.

Operation of FX3-compatible pulse catch function

When the status of the input (X0 to X7) changes OFF→ON after execution of the EI instruction, a special relay (SM8170 to SM8177) is immediately set to ON by interrupt processing. Pulse catch operates even when an input interrupt is also set in duplicate with other functions. Note, however, that the pulse catch must be set with parameters.

Examples of program

When the status of the X0 changes OFF→ON after execution of the EI instruction, SM8170 is immediately set to ON by interrupt processing. To capture input again, turn X2 ON to reset SM8170. (X0 is assumed to be set with parameters.)

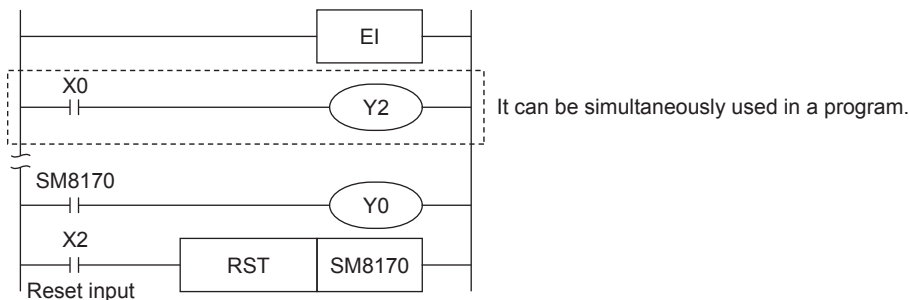

Operation diagram

An operation diagram of the above program example is shown below.

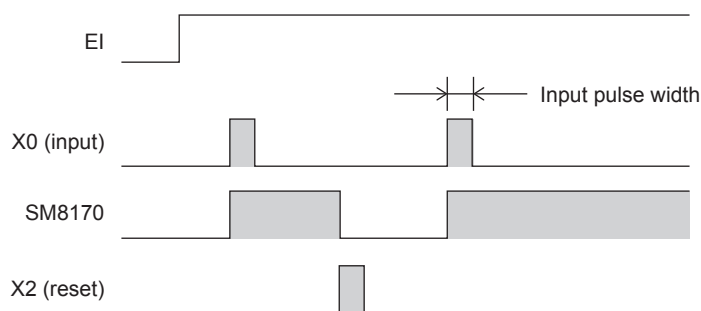

Cautions when using the FX3-compatible pulse catch function

- The FX3-compatible pulse catch function operates only when "Interrupt (Rising)" or "Interrupt (Rising) + Pulse Catch" is set with parameters.
- To capture input again, the special relay that is set must be reset by the program. Accordingly, new input cannot be captured until the special relay that is set is reset.
- The special relays for FX3-compatible pulse catch are cleared at STOP→RUN and a reset.
- The FX3-compatible pulse catch function is executed regardless of the operations of the special relays for disabling interrupts.

19.6 General-purpose Input Functions

The FX5 PLC general-purpose inputs are explained below.

Outline of general-purpose input functions

For general-purpose inputs of the FX5 PLC, the input response time can be set by parameters.

Specifications of general-purpose inputs

Performance specifications

Input response times can be set to general-purpose inputs.

Input response time setting

Input response times that can be set are shown below. The default value is 10 ms.

Input number set value	Input response time set value
X0 to X377	10 μs, 50 μs, 0.1 ms, 0.4 ms, 0.6 ms, 1 ms, 5 ms, 10 ms, 20 ms, 70 ms



The value obtained by adding on the value of the hardware filter is the actual input response time.

Hardware filter value

The delay times of the hardware filter on the CPU module is shown below.

The hardware filter value of I/O modules is 50 μs when ON, and 150 μs when OFF.

Input number		Hardware filter value	
FX5U-32M□, FX5UC-32M□	FX5U-64M□, FX5U-80M□	ON	OFF
X0 to X5	X0 to X7	2.5 μs	2.5 μs
X6 to X17	X10 to X17	30 μs	50 μs
—	X20 or later	50 μs	150 μs

Input response time setting units

The following table lists the units (1 point unit/8 point unit) that can be set for the input response time of each CPU module.

CPU module	X0 to X7	X10 to X17	X20 to X27	X30 to X37	X40 to X47
FX5U-32M□	1 point unit	1 point unit	—	—	—
FX5U-64M□	1 point unit	1 point unit	1 point unit	1 point unit	—
FX5U-80M□	1 point unit	1 point unit	1 point unit	1 point unit	8 points units ^{*1}

*1 When 1 point unit is set for the input response time using GX Works3, X41 to X47 operate with the input response time set to X40.

General-purpose input function parameters

This section explains the general-purpose input parameters.
Set the input response time parameters in GX Works3.

Parameter setting

This section explains how to set the input response time parameters.
Set the input response time.

Navigation window ⇒ [Parameter] ⇒ [FX5UCPU] ⇒ [Module Parameter] ⇒ [Input Response Time]

Window

Item	Setting
X0-X7	Specify the input response time from X0 to X7.
Response Type	High-Speed
X0	10ms
X1	10ms
X2	10ms
X3	10ms
X4	10ms
X5	10ms
X6	10ms
X7	10ms
X10-X17	Specify the input response time from X10 to X17.
Response Type	Normal
X10	10ms
X11	10ms
X12	10ms
X13	10ms
X14	10ms
X15	10ms
X16	10ms
X17	10ms

Displayed items

Item	Description	Setting range	Default
Response Type	Select the input response time between 1 point unit and 8 point unit. High-Speed: Unit of 1 point Normal: Unit of 8 points	<ul style="list-style-type: none"> High-Speed Normal 	—
X0 to X377	Set the input response time.	<ul style="list-style-type: none"> No Setting 10micro-s (μs) 50micro-s (μs) 0.1ms 0.4ms 0.6ms 1ms 5ms 10ms 20ms 70ms 	10ms



Parameters are enabled when the CPU module is powered ON or after a reset.

19.7 PWM Function

This chapter explains the PWM function.

Outline of PWM output

The CPU module has a built-in PWM function, which allows PWM output on up to four channels.

For PWM output, the output channel assignment, pulse/cycle units, output pulse logic, pulse width, cycle, etc. are set using parameters, and the HIOEN instruction is used to start/stop pulse output.

Also, the regular PWM instruction can be used.

PWM output specifications

The PWM output specifications are explained below.

Number of output channels

Up to four channels can be used for PWM output.

Output Y0 to Y7 can be selected for each channel in parameters.



Outputs (Y) assigned for PWM output in parameter settings cannot be used by the positioning function.

Pulse output performance

The cycle and pulse width are shown below.

Output number	Minimum period	Minimum pulse width
Y0 to Y3	5 μ s	2 μ s
Y4 to Y7	400 μ s	200 μ s

Relationship between cycle and pulse width

The relationship between period and pulse width is shown below.

■When positive logic is set

The relationship between the period and pulse width when the output pulse logic at start of pulse output is set to "positive logic" is shown below. (The pulse width is called the "ON width".)

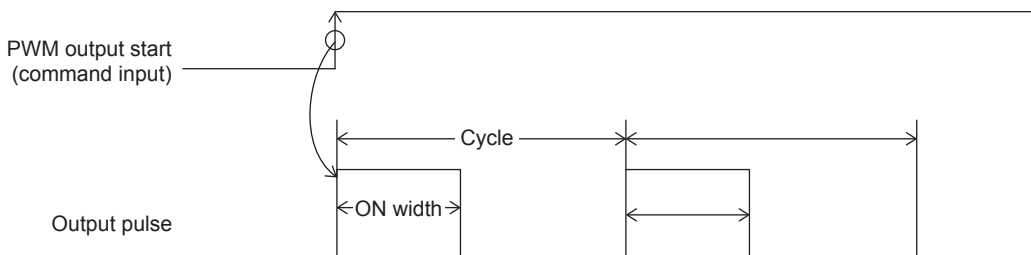

- When positive logic is set, PWM output begins from output ON.)
- Pulse output is stopped at the specified number of pulses.
- Pulse output stops in the output (Y) status of before PWM output was started.

■When negative logic is set

The relationship between the period and pulse width when the output pulse logic at start of pulse output is set to "negative logic" is shown below. (The pulse width is called the "OFF width".)

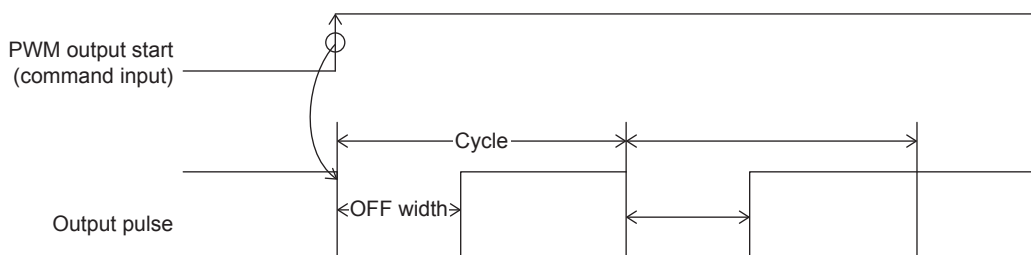

Point

- When negative logic is set, PWM output begins when the output pulse turns OFF.
- Pulse output is stopped at the specified number of pulses.
- Pulse output stops in the output (Y) status of before PWM output was started.

PWM driving method

PWM output is driven by either of the following methods.

■Driven by HIOEN instruction

The logical settings like output destination, cycle, pulse width, output pulse logic, etc. are set in parameters, and the HIOEN instruction is used to execute pulse output. For parameters, refer to [Page 195 PWM output parameters](#).

For the HIOEN instruction, refer to [MELSEC iQ-F FX5 Programming Manual \(Instructions, Standard Functions/Function Blocks\)](#).

■Driven by PWM instruction

The PWM instruction is used to execute pulse output.

For the PWM instruction, refer to [MELSEC iQ-F FX5 Programming Manual \(Instructions, Standard Functions/Function Blocks\)](#).

PWM output function execution procedure

The procedure for executing the PWM output function is explained below.

1. Check the specifications of PWM output.

Check specifications such as pulse output performance of PWM output. ([Page 193 PWM output specifications](#))

2. Connect the CPU module to the external device.

For details on wiring to external devices, refer to the following manual

[MELSEC iQ-F FX5U User's Manual \(Hardware\)](#)

[MELSEC iQ-F FX5UC User's Manual \(Hardware\)](#)

3. Set the parameters.

Set the output destination, cycle, pulse width, output pulse logic, etc. of the PWM in parameters, ([Page 195 PWM output parameters](#))

4. Create the program.

Create the program for using PWM output.

5. Run the program.

PWM output parameters

This section explains the PWM output parameters.
Set the PWM output parameters in GX Works3.

Outline of parameters

PWM output parameters are output destination, pulse width/cycle unit, output pulse logic, pulse width, and period.

Parameter setting

This section explains how to set the PWM output parameters.

Set the output destination, pulse width/cycle unit, output pulse logic, pulse width, period, etc. of the channel to be used.

 Navigation window ⇒ [Parameter] ⇒ [FX5UCPU] ⇒ [Module Parameter] ⇒ [High Speed I/O] ⇒ "Output Function" ⇒ "PWM" ⇒ "Detail Setting"

Window

Item	CH1	CH2	CH3	CH4
Use PWM Output	Set whether to use PWM output or not.			
Use/Not Use	Disable	Disable	Disable	Disable
Output Signal	Set output signal.			
Output Signal	Y0	Y0	Y0	Y0
Pulse Width/Cycle Unit	Set pulse width/cycle unit.			
Pulse Width/Cycle Unit	1ms	1ms	1ms	1ms
Output Pulse Logic	Set output pulse logic.			
Output Pulse Logic	Positive Logic	Positive Logic	Positive Logic	Positive Logic
Pulse Width	Set pulse width.			
Pulse Width	0 ms	0 ms	0 ms	0 ms
Cycle	Set cycle.			
Cycle	0 ms	0 ms	0 ms	0 ms

Displayed items

Item	Description	Setting range	Default
Use PWM Output	Set whether to use PWM output or not.	<ul style="list-style-type: none"> • Disable • Enable 	Enable
Output Signal	Set the output destination device of output signal.	Y0 to Y7	—
Pulse Width/Cycle Unit	Set pulse width/cycle unit.	<ul style="list-style-type: none"> • 1ms • 1micro-s (μs) 	—
Output Pulse Logic	Sets output pulse logic.	<ul style="list-style-type: none"> • Positive Logic • Negative Logic 	—
Pulse Width	Sets the ON/OFF width of the pulse.	<ul style="list-style-type: none"> • When pulse width/period unit is set to 1 ms 1 to 2147483 ms • When pulse width/period unit is set to 1 micro-s (μs) 1 to 2147483647 micro-s (μs) 	—
Cycle	Sets cycle.	<ul style="list-style-type: none"> • When pulse width/cycle unit is set to 1 ms 1 to 2147483 ms • When pulse width/cycle unit is set to 1 micro-s (μs) 1 to 2147483647 micro-s (μs) 	—

Point

The items specified in the parameters are stored in special devices when the CPU module is set from STOP to RUN.

List of Special relays/special registers

The list of special relays/special registers used in PWM output is shown below.

R/W: Read or write

R: Read only

Special relays/ special registers	Function	Description	Default	R/W
SM5300	Operation monitor (CH1)	The operation/stopped status of PWM output on the target channel can be checked. OFF: Stopped ON: In operation	OFF	R
SM5301	Operation monitor (CH2)			
SM5302	Operation monitor (CH3)			
SM5303	Operation monitor (CH4)			
SD5301, SD5300	CH1 number of output pulses	The number of pulses to output are stored.	0	R/W
SD5303, SD5302	CH1 pulse width	The pulse width is stored.	0	R/W
SD5305, SD5304	CH1 period	The period is stored.	0	R/W
SD5307, SD5306	CH1 Number of output pulses current value monitor	The current value of the number of output pulses is stored.	0	R
SD5317, SD5316	CH2 number of output pulses	The number of pulses to output are stored.	0	R/W
SD5319, SD5318	CH2 pulse width	The pulse width is stored.	0	R/W
SD5321, SD5320	CH2 period	The period is stored.	0	R/W
SD5323, SD5322	CH2 Number of output pulses current value monitor	The current value of the number of output pulses is stored.	0	R
SD5333, SD5332	CH3 number of output pulses	The number of pulses to output are stored.	0	R/W
SD5335, SD5334	CH3 pulse width	The pulse width is stored.	0	R/W
SD5337, SD5336	Ch3 period	The period is stored.	0	R/W
SD5339, SD5338	CH3 Number of output pulses current value monitor	The current value of the number of output pulses is stored.	0	R
SD5349, SD5348	CH4 number of output pulses	The number of pulses to output are stored.	0	R/W
SD5351, SD5350	CH4 pulse width	The pulse width is stored.	0	R/W
SD5353, SD5352	CH4 period	The period is stored.	0	R/W
SD5355, SD5354	CH4 Number of output pulses current value monitor	The current value of the number of output pulses is stored.	0	R

Details of special relays/special registers

Details of special relays/special registers used in PWM output are explained below.

Operation monitor

This monitor is a device for monitoring the in operation/stopped status of PWM output.

■Corresponding devices

The device numbers corresponding to each channel are as follows.

CH1	CH2	CH3	CH4
SM5300	SM5301	SM5302	SM5303

■Update timing

The timing of device update is as follows.

ON	OFF
<ul style="list-style-type: none"> • PWM output driven by HIOEN instruction • PWM instruction ON execution 	<ul style="list-style-type: none"> • PWM output stopped by HIOEN instruction • After end of output of the specified number of pulses • PWM instruction OFF execution • Activation contact turned OFF • Power OFF→ON, reset, RUN→STOP/PAUSE

Number of output pulses

The number of output pulses of PWM output is stored.

When "0" is set, output is continued without any limitation.

■Corresponding devices

The device numbers corresponding to each channel are as follows.

CH1	CH2	CH3	CH4
SD5301, SD5300	SD5317, SD5316	SD5333, SD5332	SD5349, SD5348

■Update timing

The timing to reflect the device in operation is as follows.

- When the HCMOV instruction is executed (values updated immediately)
- When the PWM instruction is executed
- END processing

■Clear timing

The timing when the device is cleared is as follows.

- STOP/PAUSE→RUN

Point

- If the number of output pulses written is equal to or smaller than the number of pulses that have already been output, pulse output is stopped after the pulses being currently output are completed.
- If the number of output pulses written is greater than the number of pulses that have already been output, pulse output is stopped after the specified number of pulses are output.
- If the number of output pulses is set to "0" (output without any limitation), the value cannot be changed while pulses are being output.
- The number of output pulses cannot be changed to "0" (output without any limitation) while pulses are being output.

Pulse width

The pulse width of PWM output is stored.

■Corresponding devices

The device numbers corresponding to each channel are as follows.

CH1	CH2	CH3	CH4
SD5303, SD5302	SD5319, SD5318	SD5335, SD5334	SD5351, SD5350

■Update timing

The timing to reflect the device in operation is as follows.

- When the HCMOV instruction is executed (values updated immediately)
- When the PWM instruction is executed
- END processing

■Clear timing

The timing when the device is cleared is as follows.

- STOP/PAUSE→RUN

Point

- The pulse width and cycle can be changed even while pulses are being output.
- The pulse width and cycle are stored in the unit specified by the parameter (ms or μ s).

Period

The period of PWM output is stored.

■Corresponding devices

The device numbers corresponding to each channel are as follows.

CH1	CH2	CH3	CH4
SD5305, SD5304	SD5321, SD5320	SD5337, SD5336	SD5353, SD5352

■Update timing

The timing to reflect the device in operation is as follows.

- When the HCMOV instruction is executed (values updated immediately)
- When the PWM instruction is executed
- END processing

■Clear timing

The timing when the device is cleared is as follows.

- STOP/PAUSE→RUN

Point

- The pulse width and cycle can be changed even while pulses are being output.
- The pulse width and cycle are stored in the unit specified by the parameter (ms or μ s).

Number of output pulses current value monitor

The current value of the number of output pulses of PWM output is stored.

■Corresponding devices

The device numbers corresponding to each channel are as follows.

CH1	CH2	CH3	CH4
SD5307, SD5306	SD5323, SD5322	SD5339, SD5338	SD5355, SD5354

■Update timing

The timing to reflect the device in operation is as follows.

- When the HCMOV instruction is executed (values updated immediately)
- When the PWM instruction is executed
- END processing

■Clear timing

The timing when the device is cleared is as follows.

- Power OFF→ON
- Reset
- STOP/PAUSE→RUN

Point

- If the number of output pulses is set to "0" (output without any limitation), the number of output pulse current value monitor is fixed at "0".
- The number of output pulse current value monitor can be changed even while pulses are being output.

Cautions when using the PWM function

- Set the pulse width to a value 2 μs more and period to a value 5 μs more.
- Set the value so that pulse width \leq period.
- The PWM instruction is not executed when a channel number not selected for PWM output in parameters setting is specified by the PWM instruction.

Examples of program

An example of a program using the PWM function is explained below.

Outline of operation

An example of a program using output Y0 on the CPU module to output one pulse with a delay is explained below.

Parameter setting

This program assumes that parameters are set as follows.

CH2, CH3 and CH4 need not be set.

Item	CH to be used
	CH1
Output destination	Y0
Output pulse logic	Negative logic (Output from OFF)
Pulse width	50 ms
Cycle	60 ms

Program

An operation diagram and program are shown below.

■ Operation diagram

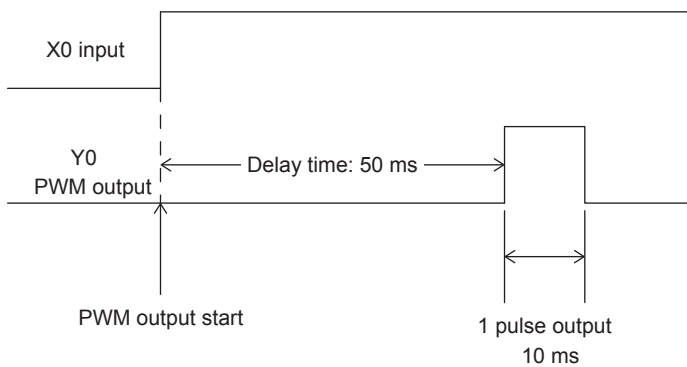

Program

- Example of program for PWM output using the HIOEN instruction

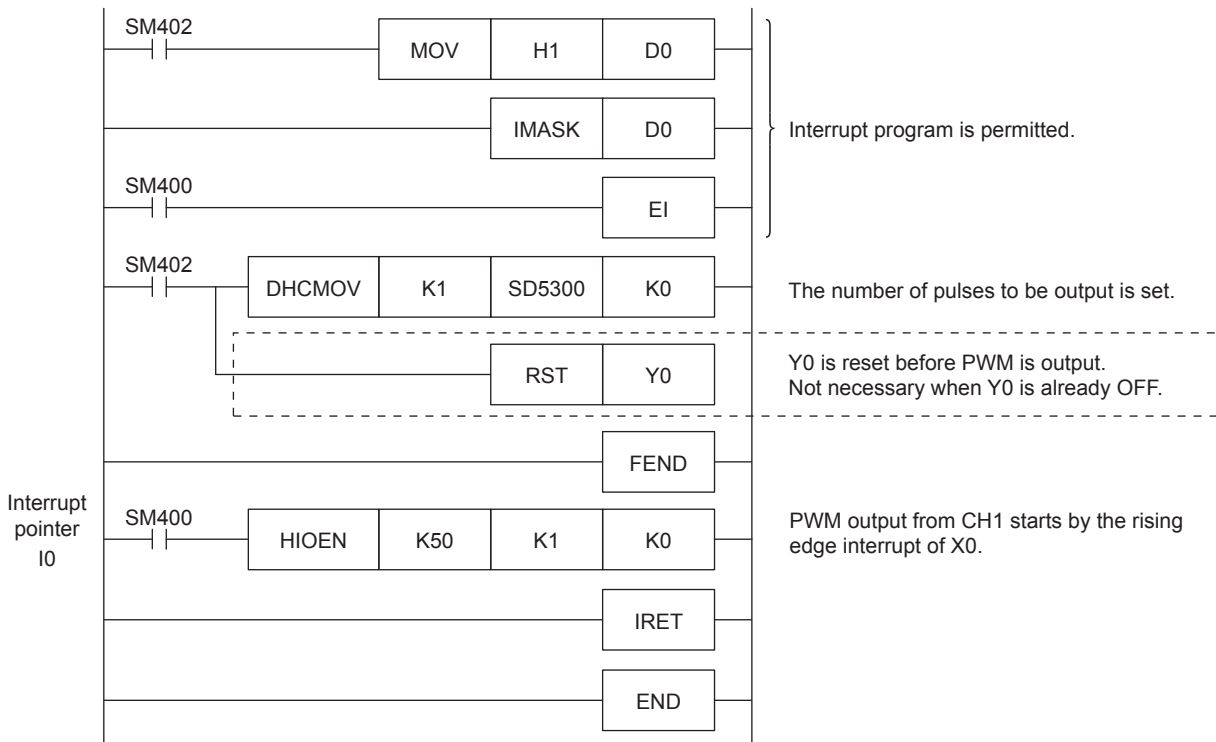

- Example of program for PWM output using the PWM instruction

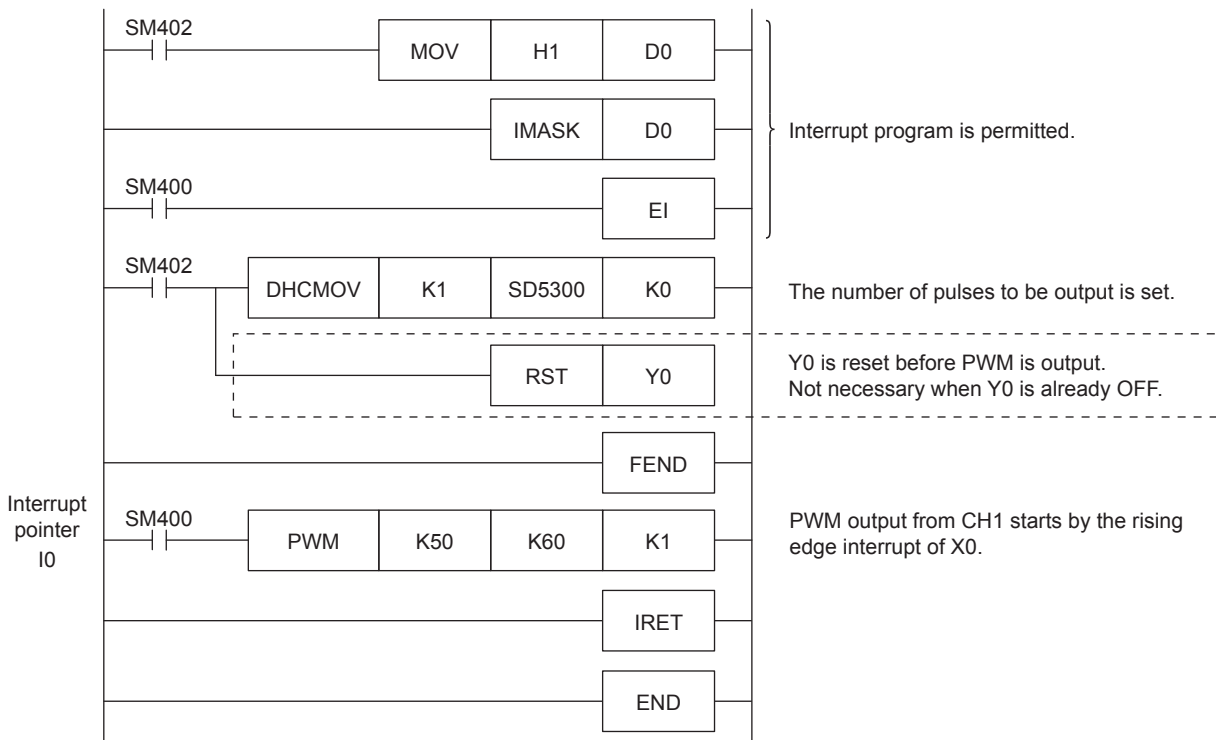

20 BUILT-IN ANALOG FUNCTION

The analog I/O terminal functions built into the FX5U CPU module are explained below.

20.1 Function Outline

There are two lines of analog voltage input and one line of analog voltage output built into the FX5U CPU module.

Functions must be configured using parameters to use the built-in analog circuits.

The values resulting from A/D conversion by the FX5U CPU module are automatically written in special registers for each channel.

By setting values into the special registers in the FX5U CPU module, the signal after D/A conversion is automatically output. For details on the function, refer to the following manual.

 MELSEC iQ-F FX5 User's Manual (Analog Control)

20.2 Analog Input/Output Specifications

Analog input/output specification is shown below.

Analog input specifications

Item	Specifications
No. of analog input points	2 points (2 channels)
Analog input	Voltage 0 to 10 V DC (input resistance 115.7 kΩ)
Digital output	Unsigned 12-bit binary
Input characteristics, max. resolution	Digital output value 0 to 4000
	Max. resolution 2.5 mV
Precision (Precision for the max. digital output value)	Ambient temperature 25 ±5°C Within ±0.5% (±20 digit ^{*1})
	Ambient temperature 0 to 55°C Within ±1.0% (±40 digit ^{*1})
Conversion speed	30 μs /CH (data refreshed every operation cycle)
Absolute max. input	-0.5 V, +15 V
Insulation method	Inside the PLC and the analog input circuit are not insulated. Between input terminals (channels) is not insulated.
No. of occupied input/output points	0 point (does not pertain to the max. No. of input/output points of the PLC.)

*1 "Digit" refers to digital values.

Analog output specifications

Item	Specifications
No. of analog output points	1 point (1 channel)
Digital input	Unsigned 12-bit binary
Analog output	Voltage 0 to 10 V DC (external load resistance 2 k to 1 MΩ)
Output characteristics, max. resolution ^{*1}	Digital input value 0 to 4000
	Max. resolution 2.5 mV
Precision ^{*2} (Precision for the max. analog output value)	Ambient temperature 25 ±5°C Within ±0.5% (±20 digit ^{*3})
	Ambient temperature 0 to 55°C Within ±1.0% (±40 digit ^{*3})
Conversion speed	30 μs (data refreshed every operation cycle)
Insulation method	Inside the PLC and the analog output circuit are not insulated.
No. of occupied input/output points	0 point (does not pertain to the max. No. of input/output points of the PLC.)

*1 There is a dead band near 0 V output, which is an area where some digital input values do not reflect analog output values.

*2 External load resistance is set to 2 kΩ when shipped from the factory. Thus, output voltage will increase somewhat if the resistance is set higher than 2 kΩ. When the resistance is 1 MΩ, output voltage increases by a maximum 2%.

*3 "Digit" refers to digital values.

List of analog input functions

List of Functions		Description
Function to enable/disable A/D conversion		Function to enable or disable A/D conversion per channel. The conversion process time can be reduced by disabling conversion for unused channels.
A/D conversion method	Sampling processing	Method of converting each analog input at END processing to generate the equivalent digital output.
	Count average	Method of averaging the count of A/D conversion values and outputting these average values as the digital signal.
	Time average	Method of averaging the time of A/D conversion values and outputting these average values as the digital signal.
	Moving average	Method of averaging the analog input for a specified count measured at every END process, and outputting these average values as the digital signal.
Function to detect over-scale		Function to detect analog input values that are over a specified range.
Scaling function		Function that converts user-defined maximum and minimum digital values in accordance with a configured scale.
Shift function		Function that adds a specified amount to the A/D conversion value. Fine adjustments during system startup can be easily performed.
Digital clipping function		Function that specifies the maximum A/D conversion value as 4000 and the minimum value as 0 when voltage is input that exceeds the input range.
Function to hold minimum and maximum values		Function that holds the minimum and maximum digital operation values.
Warning output function		Function to output warning when digital operation values exceed the specified range.

List of analog output functions

List of Functions		Description
Function to enable/disable D/A conversion		Function to enable or disable D/A conversion. When analog output is not used, the conversion process time can be reduced by disabling conversion.
Function to enable/disable D/A output		Specifies whether to output the D/A conversion value or output an offset value (HOLD setting value).
Scaling function		Function that converts user-defined maximum and minimum digital values in accordance with a configured scale.
Shift function		Function that adds a specified amount to the digital value. Fine adjustments during system startup can be easily performed.
Function to HOLD/CLEAR the analog output		Sets the digital value before D/A conversion to the previous value or clears the value (0) depending on the operation status of the CPU module (RUN, STOP, and STOP error).
Analog test when the CPU module has stopped		Outputs a user-defined analog value by setting the output enable/disable flag to enabled when the CPU module is stopped, and changing the digital value.
Warning output function		Function to output warning when digital values exceed the specified range.

PART 3

DEVICES/LABELS

This part consists of the following chapters.

21 DEVICES

22 LABELS

21 DEVICES

This chapter explains devices.

21.1 List of Devices

A list of devices is provided below.

Division	Type	Device name	Symbol	Notation
User device	Bit	Input	X	Octal
	Bit	Output	Y	Octal
	Bit	Internal relay	M	Decimal
	Bit	Latch relay	L	Decimal
	Bit	Link relay	B	Hexadecimal number
	Bit	Annunciator	F	Decimal
	Bit	Link special relay	SB	Hexadecimal number
	Bit	Step relay	S	Decimal
	Bit/word	Timer	T (Contact: TS, Coil: TC, Current value: TN)	Decimal
	Bit/word	Retentive timer	ST (Contact: STS, Coil: STC, Current value: STN)	Decimal
	Bit/word	Counter	C (Contact: CS, Coil: CC, Current value: CN)	Decimal
	Bit/Double word	Long counter	LC (Contact: LCS, Coil: LCC, Current value: LCN)	Decimal
	Word	Data register	D	Decimal
	Word	Link register	W	Hexadecimal number
	Word	Link special register	SW	Hexadecimal number
System device	Bit	Special relay	SM	Decimal
	Word	Special register	SD	Decimal
Module access device (U□\G□)	Word	Module access device	G	Decimal
Index register	Word	Index register	Z	Decimal
	Double word	Long index register	LZ	Decimal
File registers	Word	File registers	R	Decimal
Nesting	—	Nesting	N	Decimal
Pointer	—	Pointer	P	Decimal
	—	Interrupt pointer	I	Decimal
Constant	—	Decimal constant	K	Decimal
	—	Hexadecimal constant	H	Hexadecimal number
	—	Real constant	E	—
	—	Character string constant	—	—

Point

Specify code of timer/retentive timer/counter/long counter by T/ST/C/LC if type is determined like instruction when specifying device. If type is not determined, specify by code from among contact, coil or current value according to type. Current value can however also be specified by T/ST/C/LC.

21.2 User Devices

This section explains user devices.

Input (X)

Provides the CPU module with commands and data by external devices such as push buttons, selector switches, limit switches, digital switches, etc.

Push-button switch



Selector switch



Digital switch

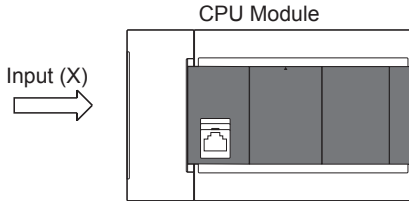
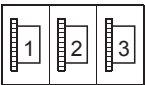

Concept of input

You can think each input point as having a virtual relay Xn built into a single CPU module. The program uses NO/NC contact of Xn.

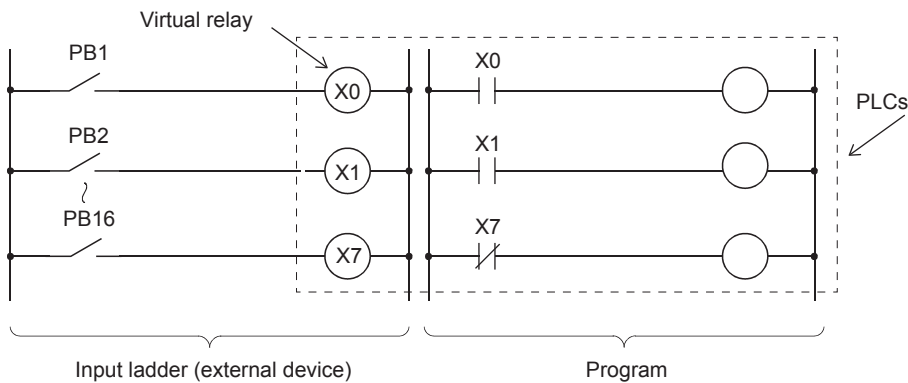

Output (Y)

Outputs program control results to external signal lamps, digital indicators, contactors, solenoids, etc.

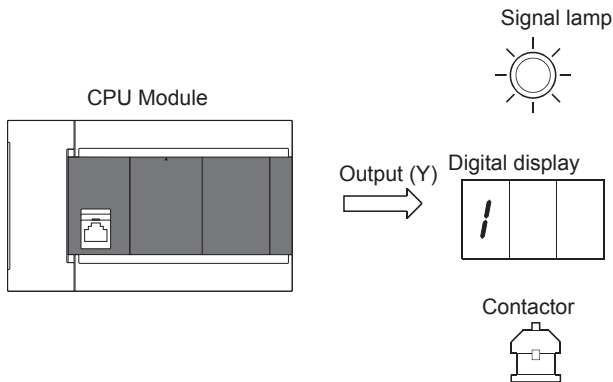

Internal relay (M)

Device intended to be used as an auxiliary relay inside the CPU module. All internal relays are turned OFF by the following operation.

- CPU module power OFF→ON
- Reset
- Latch clear

Latch relay (L)

Auxiliary relay that can latch (backup by battery) in the CPU module. Computation results (ON/OFF information) are latched even when performing the following operations.

- CPU module power OFF→ON
- Reset

Link relay (B)

Device intended to be used as a CPU side device when refreshing bit data between CPU module and network module.

Refreshing network module that uses link relay (B)

Sends/receives data mutually between network module link relays (LB) and link relay (B) in the CPU module. Set refresh range by parameters of the network module. Link relays not used for refresh can be used for other purposes.

Annunciator (F)

Internal relay used for program for detecting equipment errors/faults created by the user. When the annunciator (F) is turned ON, SM62 (Annunciator (F) Detection) turns ON, and the number of annunciator devices that are ON and their numbers are stored from SD62 (Annunciator (F) Detection No.) to SD79 (Annunciator (F) Detection No. Table).

Fault detection program

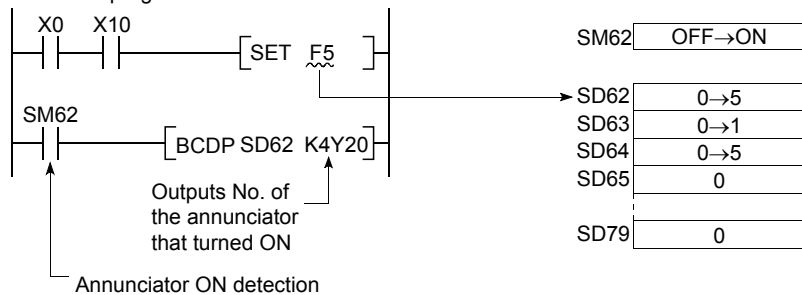

How to turn annunciator (F) ON

Use SET F□ instruction. The annunciator (F) turns ON only during the rise time of input conditions (OFF→ON); the annunciator (F) remains ON even if the input condition is OFF.

Point

- The annunciator (F) can also be turned ON by OUT F□ instruction, but because it is processed every scan, scan time is slower than when using SET F□ instruction.
- If it is turned ON by means other than SET F□ instruction or OUT F□ instruction (e.g. MOV instruction), operation is the same as for internal relay. Thus, in SM62 does not turn ON, and annunciator (F) numbers are not stored in SD62 and SD64 (Annunciator (F) Detection No. table) to SD79.

Processing when annunciator (F) is ON

Data stored in the special register becomes as follows.

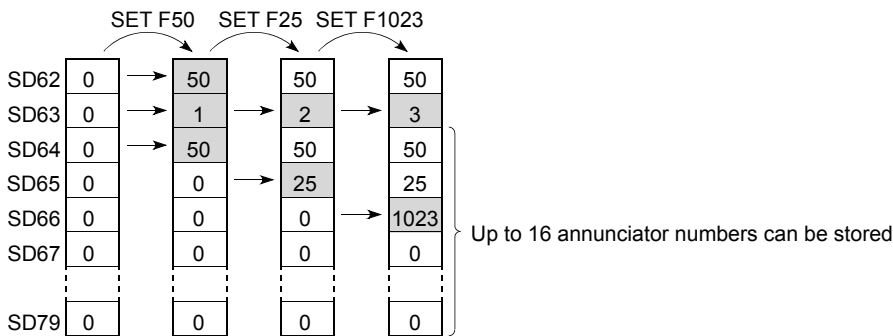

1. Annunciator (F) numbers that are ON are stored in SD64 to SD79 in sequence.
2. Annunciator (F) numbers that are stored in SD64 are stored in SD62.
3. Increments contents of SD63 (Annunciator (F) Detection Number) by +1.

Point

If 17 or more annunciator's are ON, the numbers are not stored in SD64 to SD79.

How to turn annunciator (F) OFF

Annunciators (F) are turned OFF by the following instruction.

Instruction	Application
RST F□ instruction	Used to turn OFF annunciator (F) number set by SET F□ instruction.
BKRST instruction	Used to turn a specified range of annunciator (F) numbers OFF in a batch.

Point

You can turn OFF by OUT F□ as well, but "Processing when annunciator (F) is OFF" described below is not carried out even if annunciator numbers are turned OFF by OUT F□ instruction. If annunciator (F) numbers are turned OFF by OUT F□ instruction, you must execute the RST F□/BKRST instruction given above.

■ Processing when annunciator (F) is OFF

Data stored in the special register becomes as follows.

- Data stored in SD62 to SD79 when RST F□ instruction or BKRST instruction is executed
1. Annunciator (F) numbers specified in the RST F□ instruction or the BKRST instruction are erased, and annunciator (F) numbers stored subsequent to those erased are moved up.
 2. If annunciator (F) numbers stored in SD64 are turned OFF, new annunciator (F) numbers stored in SD64 are stored in SD62.
 3. Decrements contents of SD63 by -1. If SD63 is "0", SM62 is turned OFF.

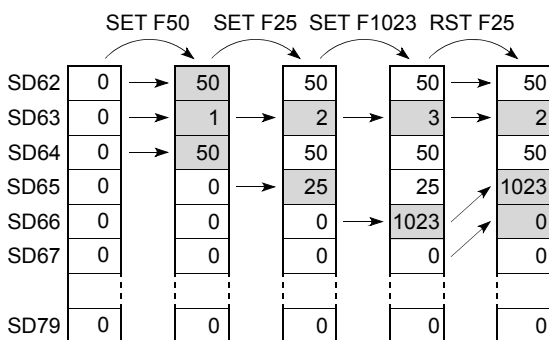

Link special relay (SB)

Communication and error detection status of network modules are output to link special relays within the network. Link special relays (SB) are devices intended to be used as a refresh destination for link special relays within the network. Link special relays not used for refresh can be used for other purposes.

Step relay (S)

Device used with step ladder Instructions. Where step ladder is not used, it can be used for purposes such as auxiliary relay.

Timer (T/ST)

Device whereby measurement starts when the timer coil is turned ON, time up occurs when current value reaches the setting value, and the contact is turned ON. The timer is an addition type counter. When time is up, the current value and setting value are the same value.

Types of timers

There are timers (T) for which current value is maintained in 16 bits, and retentive timers (ST) that maintain the current value even when the coil is turned OFF.*1

*1 Current value of timers (T) becomes "0" when the coil is turned OFF.

■Timer (T)

Measurement starts when the timer's coil is turned ON. Time up occurs when the current value of the timer matches the setting value and the timer's contact is turned ON. When the timer's coil is turned OFF, the current value becomes "0" and the timer's contact is turned OFF.

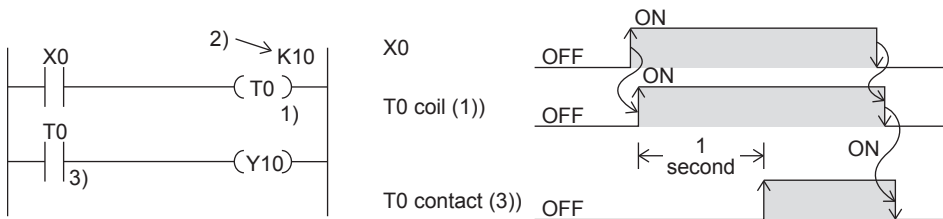

■Retentive timer (ST)

Measures time for which the coil is ON. Measurement starts when the retentive timer's coil is turned ON, and when the current value matches the setting value (time up), the retentive timer's contact is turned ON. The current value and ON/OFF status of the contact are maintained even if the retentive timer's coil is turned OFF. When the coil is turned back ON, measurement resumes from the current value maintained. The current value is cleared and the retentive timer is turned OFF by the RST ST□ instruction.

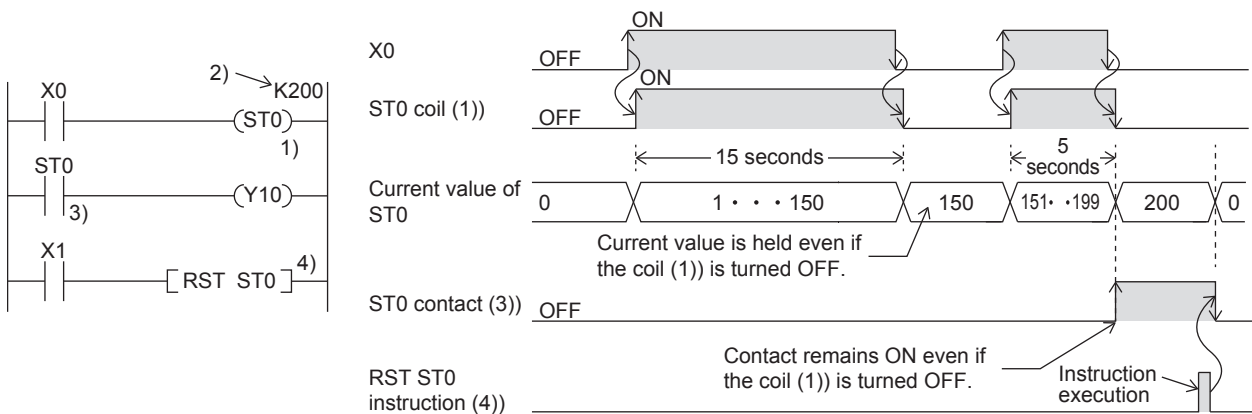

■Low-speed timer/Timer/High-speed timer (T/ST)

Low-speed timers, timers and high-speed timers are the same device. The timer is specified (by instruction) as a low-speed timer, timer, or high-speed timer. If for example, you specify "OUT T0," the timer is a low-speed timer (100 ms); if you specify "OUTH T0," it is a timer (10 ms); if you specify "OUTHHS T0," it is a high-speed timer (1 ms). The same goes for retentive timers.

■Routine timer (T)

The routine timer is a timer (100ms) that can operate even with a program that is not necessarily executed with every scan. Eight timers can be used at the maximum. This timer counts when the OUT T□ instruction, the ANS instruction, or the END instruction is executed.

To use a routine timer, it is necessary to set the parameter. (Page 211 Routine timer setting)

Current value and measurement range of timer

■Timer

The current value range is 0 to 32767.

Timer processing method

The timer's coil is turned ON/OFF, the current value is updated and the contact is turned ON/OFF when timer's coil (OUT T□ instruction) is executed.

The difference between a timer and a routine timer

Described below is the difference between a timer and a routine timer.

Item	Timer	Routine timer
Resolution	100 ms/10 ms /1 ms	100 ms
The timing of counting (count up)	When the OUT T□ instruction or the ANS instruction is executed	<ul style="list-style-type: none">• When the OUT T instruction or the ANS instruction is executed• If the OUT T instruction or the ANS instruction is not executed, the counting starts when the END instruction is executed.
The timing of time up (the operation at the output contact)	When the OUT T□ instruction or the ANS instruction is executed	<ul style="list-style-type: none">• When the OUT T instruction or the ANS instruction is executed• When the END instruction is executed
Device	T, ST	T

Precautions when using timers

Precautions when using timers are as follows.

- Do not specify the same timer coil (OUT T□ instruction) more than once per scan. If you do, the current value of the timer is updated when each respective timer coil is executed, so measurement cannot be performed normally.
- If timer is not executed each scan: You cannot skip a timer coil (OUT T□ instruction) with the CJ instruction, etc., while the timer's (T1 for example) coil is ON. If a timer's coil is skipped, the timer's current value is not updated, so measurement cannot be performed normally. If a timer (T1 for example) exists within a subroutine program, be sure to execute the subroutine coil that includes the T1 coil only once per scan while that timer's coil is ON. If not executed, measurement cannot be performed normally.
- The timer cannot be used in the initial execution type program, fixed scan execution type program, or event execution type program. The timer can be used in standby type programs if the coil of timer (OUT T□ instruction) is executed one time for one scan using a subroutine program.
- The timer cannot be used in interrupt programs. The timer can be used in subroutine programs or FB programs if the coil of timer (OUT T□ instruction) is executed one time for one scan.
- If setting value is "0": The contact is turned ON when the OUT T□ instruction is executed.
- If setting value is modified after time up: The timer remains in time up status and does not operate even if the setting value is raised higher than the current value after time up.

Routine timer setting

The setting of the routine timer is made.

Navigation window ⇒ [Parameter] ⇒ [FX5UCPU] ⇒ [CPU Parameter] ⇒ "Memory/Device Setting" ⇒ "Device/Label Memory Area Setting"

Window

Item	Setting
Device/Label Memory Area Detailed Setting	
Device (high speed) Setting	<Detailed Setting>
Device (Standard) Setting	<Detailed Setting>
Latch type setting of the latch relay (L)	Latch (1)
Latch Label Latch Type	Latch (1)
Latch area of the latch label	Standard Latch Area
To use or not to use the routine timer of timer (T)	Not Use
Start device No. of routine timer of timer (T)	0

21

Displayed items

Item	Description	Setting range	Default
To use or not to use the routine timer of timer (T)	Whether the routine timer is used is set.	<ul style="list-style-type: none"> • Not use • Use 	Not use
Start device No. of routine timer of timer (T)	The initial device of the routine timer is set.	0 to 1023	0

Counter (C/LC)

Device that counts number of rises of input conditions in the program. Counters are addition type counters; they count up when the count value matches the setting value, and the contact is turned ON.

For details on the FX3-compatible high-speed counter, refer to  Page 165 FX3-compatible high-speed counter function.

Counter type

There is counter (C) that maintains the counter value in 16 bits and the long counter (LC) that maintains the counter value in 32 bits. Counter (C) and long counter (LC) are separate devices. You can set number of device points for each.

■Counter (C)

Uses 1 word as 1 point. The counting range is from 0 to 32767.

■Long counter (LC)

Uses 2 words as 1 point. The counting range is from 0 to 4294967295.

Count processing

Count processing is as follows when counter's coil is executed.

■When the OUT C□ instruction/OUT LC□ instruction is executed

The counter's coil is turned ON/OFF, the current value is updated (count value +1) and contact ON/OFF processing is executed.

■Current value update (count value +1)

Current value is updated (count value +1) when counter coil input rises (OFF→ON). Current value is not updated when coil input is OFF, ON, or turned ON→OFF.

[Ladder example]



[Current value update timing]

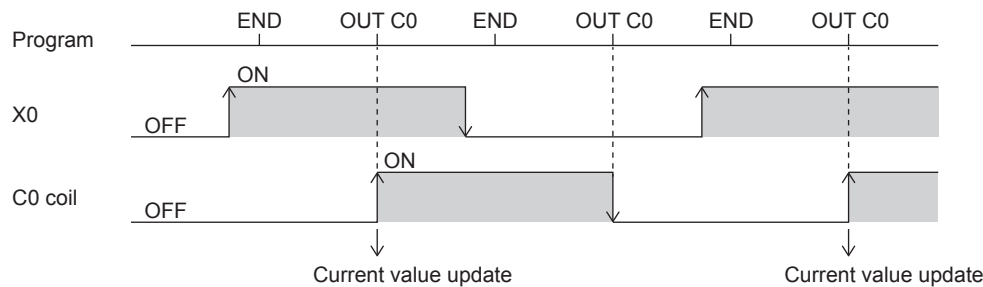

Counter reset

Current value of counters is not cleared even if its coil input is turned OFF. To clear (reset) the current value of the counter and turn the contact OFF, use the RST C□ instruction/RST LC□ instruction. The counter value is cleared and the contact is turned OFF as soon as the RST C□ instruction is executed.

[Ladder example]

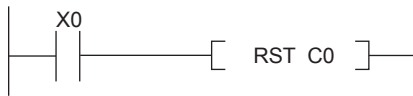

[Counter reset timing]

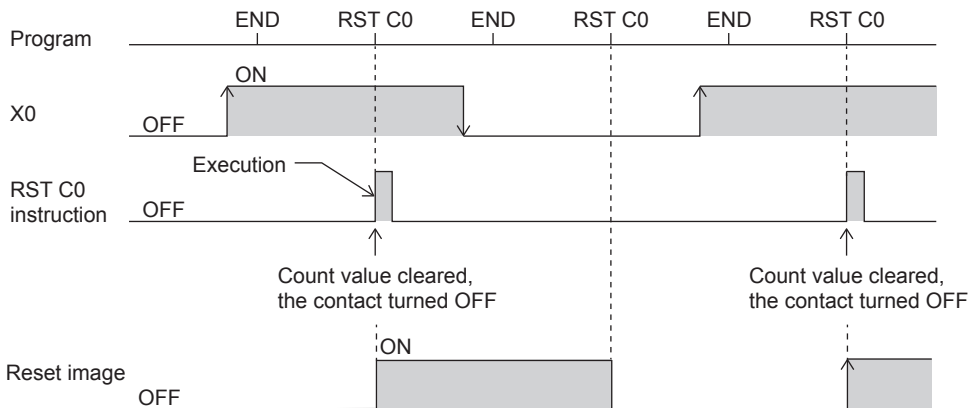

Precautions when performing counter reset

- When the RST C□ instruction is executed, C□ coil is also turned OFF. If the execution conditions for the OUT C□ instruction are ON after the RST C□ instruction is executed, the C□ coil is turned ON when the OUT C□ instruction is executed, and the current value is updated (count value +1).

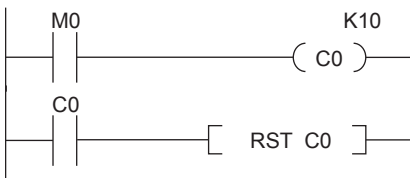

In the example circuit given above, the C0 coil is turned ON by M0 turning OFF→ON, and the current value is updated. When C0 counts up, the C0 contact turns ON, and current value of C0 is cleared by execution of the RST C0 instruction. The C0 coil is also turned OFF at this time. If M0 is ON for the next scan, the C0 coil turns OFF→ON when the OUT C0 instruction is executed, so the current value is updated. (Current value becomes "1".)

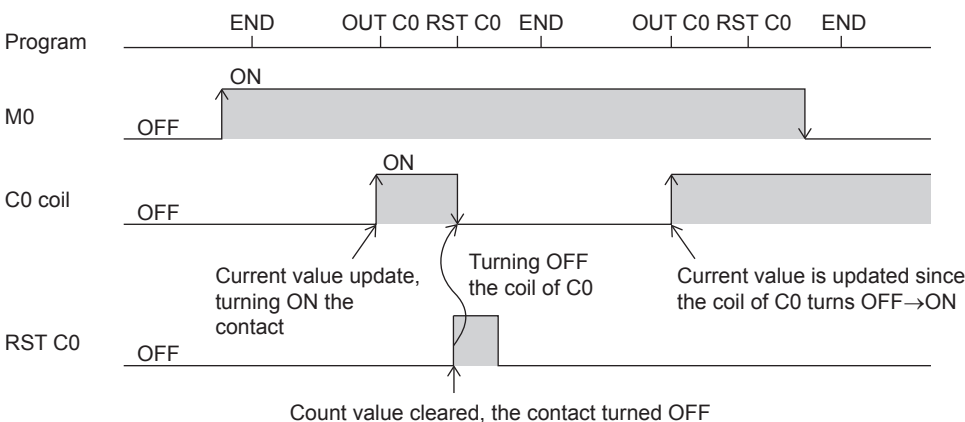

To handle this, arrange so that C0 coil is not turned OFF while OUT C0 instruction execution condition (M0) is ON, by inserting the NC contact execution condition of the OUT C0 instruction in the execution condition of the RST C0 instruction as shown by the following circuit example.

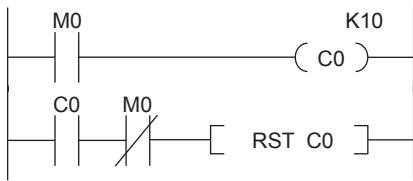

- When a counter is reset by the RST instruction, it cannot count until the RST instruction is set to OFF.

[Program example]

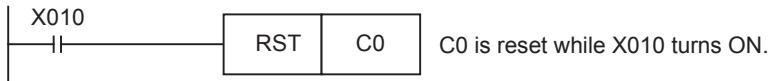

[Timing chart]

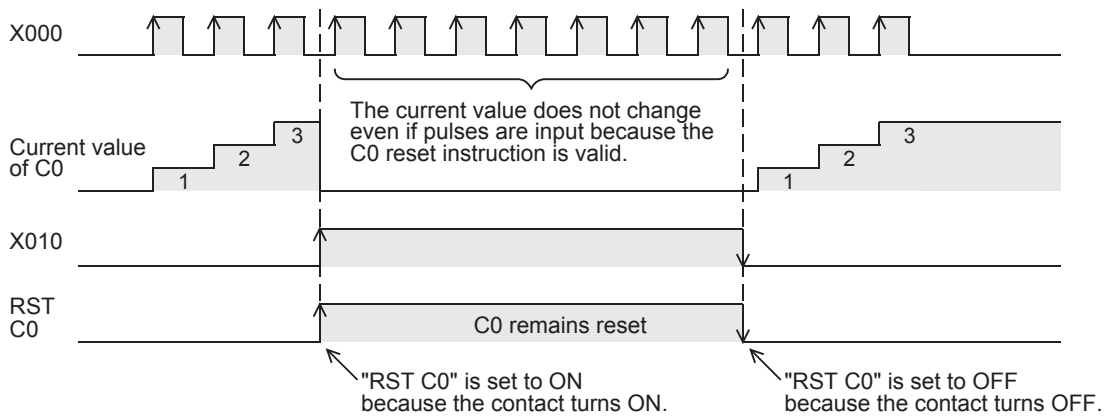

- When the counter is set as a latch device, the current value of a counter, output contact operation, and the reset image are latched.
- If the ZRST instruction is used, the RST image of a counter is reset.

Data register (D)

Device capable of storing numerical data.

Link register (W)

Device intended to be used as a CPU side device when refreshing word data between CPU module and network module.

Refreshing network module that uses link register (W)

Sends/receives data mutually between link registers (LW) in network module and link register (W) in the CPU module. Set refresh range by parameters of the network module. Link registers not used for refresh can be used for other purposes.

Link special register (SW)

Word data such as communication and error detection status information of network modules is output to link special relays within the network. Link special registers (SW) are devices intended to be used as a refresh destination for link special registers within the network. Link special registers not used for refresh can be used for other purposes.

21

21.3 System Devices

System devices are devices for the system. Assignment/capacity are fixed and cannot be changed by the user.

Special relay (SM)

The PLC contains internal relays with fixed specifications, so it cannot be used in the program like a conventional internal relay. It can however be turned ON/OFF to control the CPU module as needed. (☞ Page 224 Special Relay List)

Special register (SD)

The PLC contains internal register with fixed specifications, so it cannot be used in the program like a conventional internal register. Data, however, can be written to control the CPU module as needed. (☞ Page 240 Special Register List)

21.4 Module Access Device

Device that allows you to directly access the buffer memory of intelligent function modules connected to the CPU module from the CPU module.

Specification method

Specified by U [module number of intelligent function modules][buffer memory address].

(Example: U5\G11)

Processing speed

Processing speed of reading/writing by module access device is slightly faster than using FROM/TO instruction. (Example: MOV U2\G11 D0) When reading the buffer memory of a module access device and executing another process by 1 instruction, the processing speed would be approximately the total of processing speed of FROM/TO instruction and processing speed of instruction. (Example: +U2\G11 D0 D10)

Point

If reading/writing data of the buffer memory using module access device at least 2 times in the program, you can speed up processing time by reading/writing at a single place in the program using a FROM/TO instruction.

- Writing using multiple module access devices

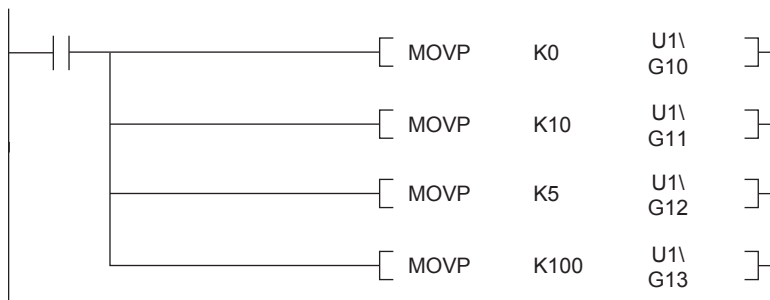

- Writing at single place in program using TO instruction

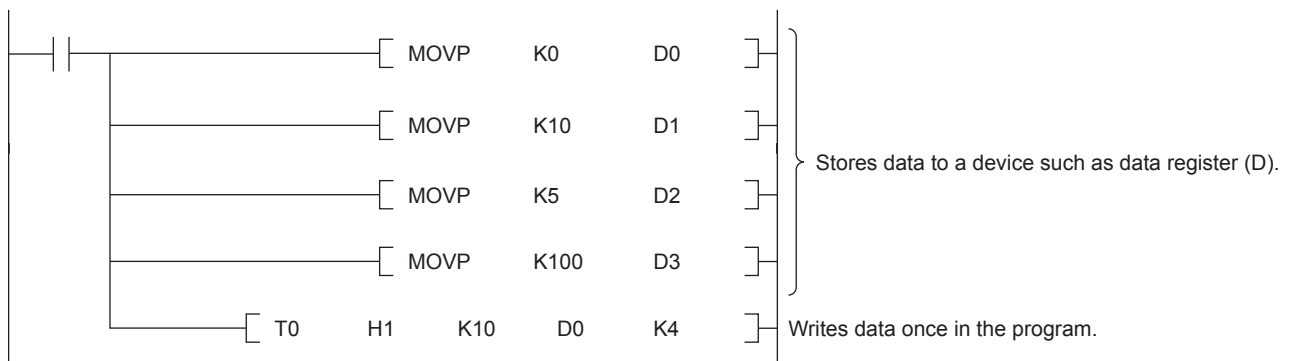

21.5 Index Registers (Z/LZ)

Device used for indexing of devices.

Types of index registers

There are 2 types: the index register (Z) and long index register (LZ)

Index register (Z)

Used for 16-bit index modification.

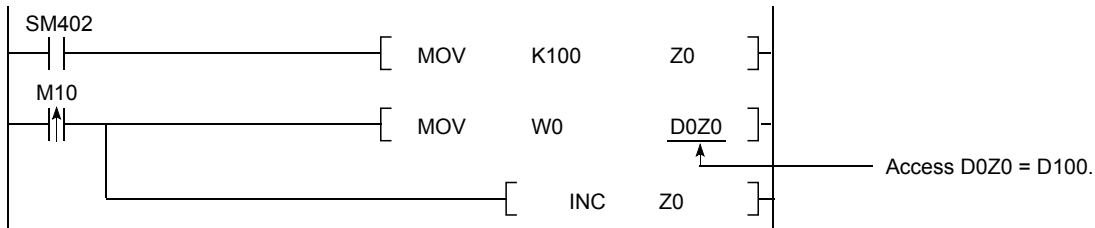

Long index register (LZ)

Used for 32-bit index modification.

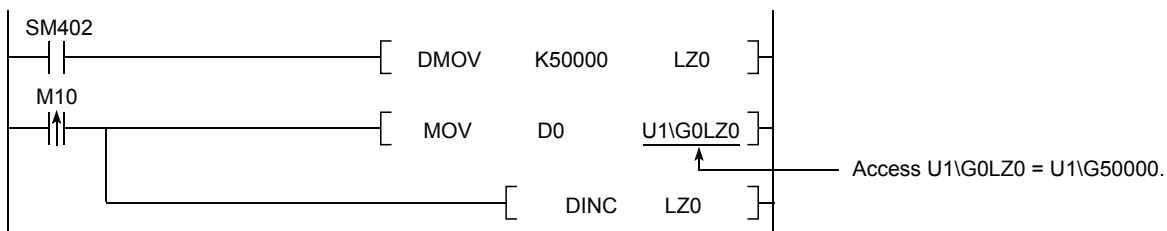

Index register setting

A total of 24 words can be used for index register (Z) and long index register (LZ). The number of points can be changed by parameter.

Navigation window ⇒ [Parameter] ⇒ [FX5UCPU] ⇒ [CPU Parameter] ⇒ "Memory/Device Setting" ⇒ "Index Register Setting"

Window

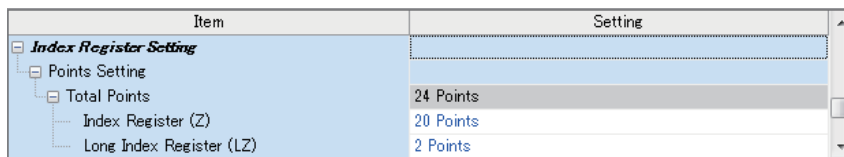

Displayed items

Item	Description	Setting range	Default
Total Points	Show the total number of points for index register and long index register.	—	—
Index Register (Z)	Set the number of points for index registers.	0 to 24 points (2 point unit)	20 points
Long Index Register (LZ)	Set the number of points for long index registers.	0 to 12 points (1 point unit)	2 points

21.6 File Register (R)

Device capable of storing numerical data.

21.7 Nesting (N)

Device for programming operating conditions by nesting using master control instructions (MC/MCR instruction)*1. Operation conditions are specified in ascending order (N0 to N14) from outside the nesting.

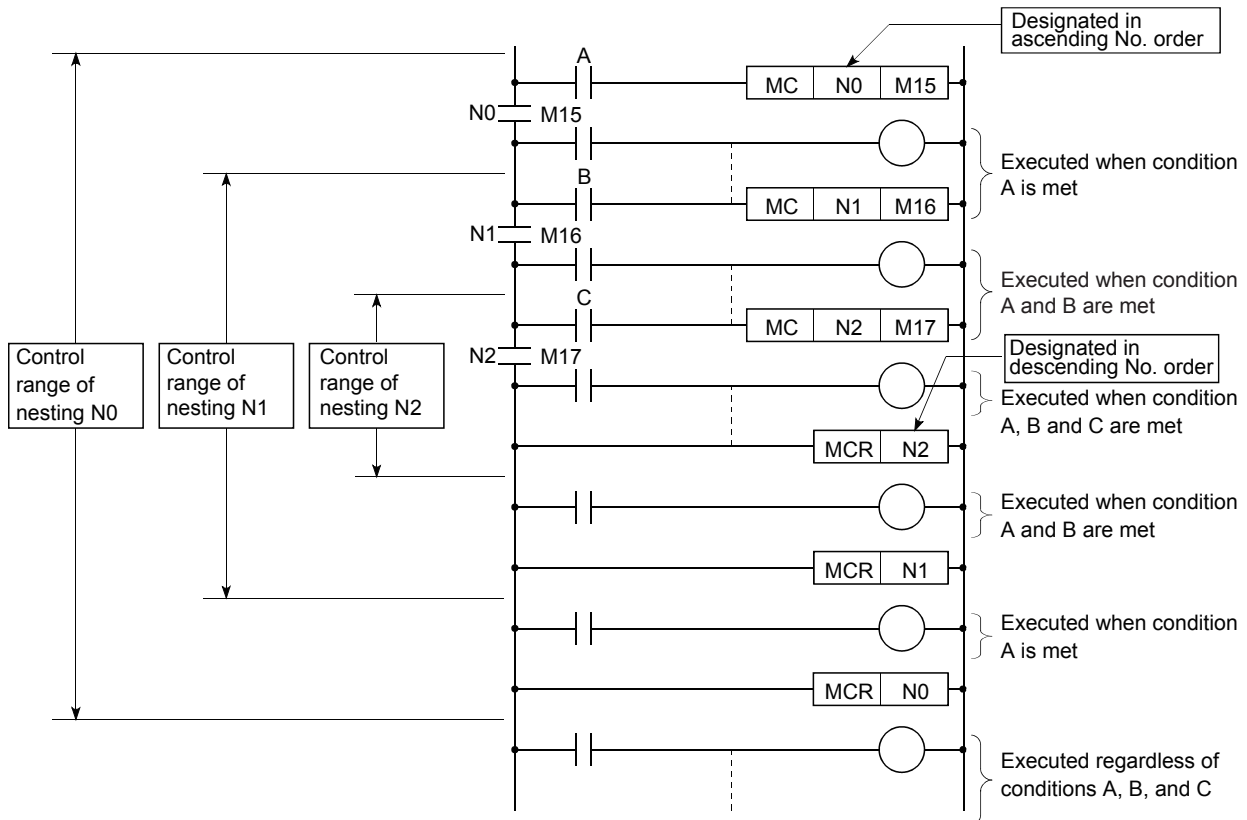

*1 Instruction for creating an efficient circuit switching program by switching common bus of the circuit.

21.8 Pointer (P)

Device used by instructions such as jump instruction (CJ instruction) and subroutine program call instruction (CALL instruction, etc.). Types of pointers are as follows.

Pointer	Description
Global pointers	Pointers that can be referred to from all programs.
Label assignment pointers	Pointers used by assignment to labels. Pointer numbers assigned to labels are automatically determined by engineering tool; the user cannot specify pointer numbers to be assigned.

Pointers are used for the following purposes.

- Specifies label and where to jump to for jump instruction (CJ instruction).
- Specifies label (top of subroutine program) and call destination of subroutine instruction (CALL instruction, etc.).

Global pointers

Pointer for calling subroutine from all programs being run.

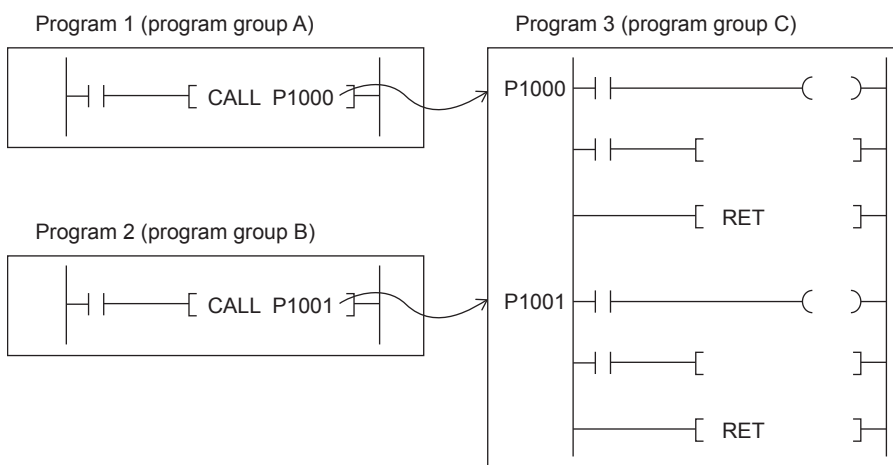

Precautions when using global pointers

- A global pointer of the same pointer number cannot be set as a label for more than one location.
- The initial pointer number for global pointers is fixed to "0".

Label assignment pointers

Pointer assigned to pointer type labels. Pointer for label assignment are automatically assigned to pointer type labels by engineering tool. Pointer numbers of pointers for label assignment cannot be directly specified. By defining pointer type labels, you can specify destination for jump instruction or subroutine program by label instead of pointer such as P0.

21.9 Interrupt Pointer (I)

Device used as label at top of interrupt program. Can be used by all running programs.

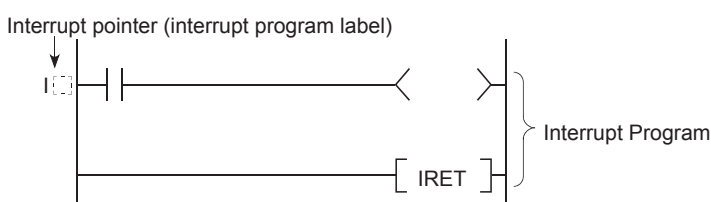

Point

Setting the execution type of program to the event execution type eliminates the need to write (I□) the interrupt pointer. (Page 25 Generation of interrupt by interrupt pointer (I))

Interrupt causes of the interrupt pointer numbers

A list of interrupts is provided below.

Interrupt	Interrupt pointer number	Description
Input interrupt	I0 to I15	interrupt pointer used for input interrupt of CPU module. Up to 8 points can be used.
High-speed comparison match interrupt	I16 to I23	Interrupt pointer used for high-speed comparison match interrupt of CPU module.
Interrupt by internal timer	I28 to I31	Interrupt pointer used for fixed cycle interrupt by internal timer.
Interrupt from module	I50 to I177	interrupt pointer used for interrupt from intelligent function module.

The priority for the interrupt pointer numbers and interrupt factors

The priority for the interrupt pointer numbers and interrupt factors are indicated.

Interrupt pointer number	Interruption cause	Interrupt priority	Interrupt priority order	Remarks
I0	Input interrupt	1 to 3	1	The default value for priority is "2".
I1				
I2				
I3				
I4				
I5				
I6				
I7				
I8				
I9				
I10				
I11				
I12				
I13				
I14				
I15				
I16	High-speed comparison match interrupt	1 to 3	17	The default value for priority is "2".
I17				
I18				
I19				
I20				
I21				
I22				
I23				
I28	Interrupt by internal timer	1 to 3	28	The default value for priority is "2".
I29				
I30				
I31				
I50 to I177	Interrupt from module	2 to 3	29 to 156	The default value for priority is "3". The highest priority rank is I50 and the lowest is I177.

Point

- The interrupt priority is the order which is executed at the time of the multiple interrupt. The lower the numerical value, the higher the interrupt priority.
- The interrupt priority order is the order which is executed when the interrupt factor with the same interrupt priority is generated.

21.10 Constant

This section explains constants.

Decimal constant (K)

Device that specifies decimal data for the program. Specified by K□. (Example: K1234)

The specification range is determined by type of argument data of instruction using a decimal constant.

Argument data type of instruction		Specification range of decimal constants
Data size	Data type name	
16 bits	Word (signed)	K-32768 to K32767
	Word (unsigned)/Bit string (16-bit)	K0 to K65535
32 bits	Double word (signed)	K-2147483648 to K2147483647
	Double word (unsigned)/Bit string (32-bit)	K0 to K4294967295

Hexadecimal constant (H)

Device that specifies hexadecimal data for the program. Specified by H□. (Example: H1234)

When specifying BCD data, specify each digit of hexadecimal number in 0 to 9. The specification range is determined by type of argument data of instruction using a hexadecimal constant. If data size is 16 bits, H0 to HFFFF; if 32 bits, H0 to HFFFFFFFF.

Real constant (E)

Device that specifies real numbers for the program. Specified by E□. (Example: E1.234)

Setting range of real numbers

The setting range of real numbers is explained below.

$$-2^{128} \leq \text{Device} \leq -2^{-126}, 0, 2^{-126} \leq \text{Device} \leq 2^{128}$$

(E-3.40282347+38 to E-1.17549435-38, 0, E1.17549435-38 to E3.40282347+38)

Operation during calculation

■ Operation at overflow and underflow

Operation is as follows if overflow or underflow occurs during calculation.

- Overflow: Error occurs.
- Underflow: Becomes "0" without error occurring.

■ Operation when special value^{*1} is input

If calculation is performed when input data is a special value, an error occurs. If "-0" occurs during calculation, it is treated as "+0"; the calculation result does not become "-0".

*1 Special values are -0, denormalized numbers, non-numbers, ±∞.

Programming expressions

Real numbers can be specified by the following expressions.

- Normal expression: Specify a numeric value as it is. (Example: E10.2345 in the case of 10.2345)
- Scientific notation: Specify a numeric value in the format "numeric value" ×10ⁿ. (Example: E1.234+3 in the case of 1234. "+3" represents "10³".)

Character string constant

Device that specifies character string. Shift JIS code character strings can be used. Character strings end with NULL character (00H). Specify by "character string".

22 LABELS

Label is identifier (character string) that specifies a character string in I/O data or internal processing. When a label is used in programming, a program can be created without being conscious about the device No. ^{*1}

*1 Label and device can be used in mixed manner.



For details on label, refer to the following.

MELSEC iQ-F FX5 Programming Manual (Program Design)

MEMO

APPENDIX

Appendix 1 Special Relay List

Diagnostic information

The special relays for diagnostic information are shown below.

R: Read only, R/W: Read/Write

No.	Name	Description	R/W
SM0	Latest self diagnostics error (including annunciator ON)	OFF: No error ON: Error	R
SM1	Latest self diagnostics error (not including annunciator On)	OFF: No self-diagnosis errors ON: Self-diagnosis error	R
SM50	Error reset	OFF→ON: Error reset request ON→OFF: Error reset completion	R/W
SM51	Battery low latch	OFF: Normal ON: Battery low	R
SM52	Battery low	OFF: Normal ON: Battery low	R
SM53	AC/DC DOWN	OFF: No AC/DC down detection ON: AC/DC down is detected	R
SM56	Instruction execution fault	OFF: Normal ON: Operation error	R
SM61	I/O module verify error	OFF: Normal ON: Error	R
SM62	Annunciator	OFF: Not detected ON: Detected	R
SM80	Detailed information 1: Flag in use	OFF: Not used ON: In use	R
SM112	Detailed information 2: Flag in use	OFF: Not used ON: In use	R

System information

The special relays for system information are shown below.

R: Read only, R/W: Read/Write







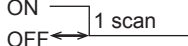
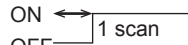

No.	Name	Description	R/W
SM203	STOP contact	OFF: Other than STOP state ON: STOP state	R
SM204	PAUSE contact	OFF: Other than PAUSE state ON: PAUSE state	R
SM210	Clock data set request	OFF→ON: Set Request ON→OFF: Set completed	R/W
SM211	Clock data set error	OFF: No error ON: Error	R
SM213	Clock data read request	OFF: Ignored ON: Read request	R/W

System clock

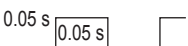
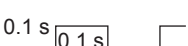
The special relay about system clock is shown below.

R: Read only, R/W: Read/Write

No.	Name	Description	R/W
SM400	Always ON	ON _____ OFF	R

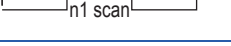
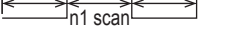
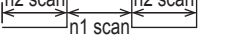
No.	Name	Description	R/W
SM401	Always OFF	ON OFF 	R
SM402	After RUN, ON for one scan only	ON  OFF	R
SM403	After RUN, OFF for one scan only	ON  OFF	R
SM409	0.01 second clock		R
SM410	0.1 second clock		R
SM411	0.2 second clock		R
SM412	1 second clock		R
SM413	2 second clock		R
SM414	2n second clock		R
SM415	2n ms clock		R
SM420	Timing clock output 1		R
SM421	Timing clock output 2		R
SM422	Timing clock output 3		R
SM423	Timing clock output 4		R
SM424	Timing clock output 5		R

Drive information

The special relays for drive information are shown below.

R: Read only, R/W: Read/Write

No.	Name	Description	R/W
SM600	Memory card usable	OFF: Unusable ON: Use enabled	R
SM601	Memory card protect	OFF: Not protected ON: Protected	R
SM603	Memory card insertion	OFF: No drive 2 ON: Drive 2 present	R

No.	Name	Description	R/W
SM605	Memory card interchange protect	OFF: Remove/insert enabled ON: Remove/insert prohibited	R/W
SM606	Memory card disable request	OFF: Clear command ON: Command	R/W
SM607	Memory card disable status	OFF: Not disabled by SD memory card forced stop request ON: Disabled by SD memory card forced stop request	R
SM632	Data memory write error detection	OFF: Write not executed/normal ON: Write error	R
SM633	Data memory writing	OFF: Write not executed ON: Writing	R
SM634	Data memory write count error detection flag	OFF: Overwrite count is less than 20,000 ON: Overwrite count is 20,000 or more	R

Instruction related

The special relays related to instruction execution are shown below.

R: Read only, R/W: Read/Write

No.	Name	Description	R/W
SM700	Carry flag	OFF: Carry OFF ON: Carry ON	R
SM701	Output characters selection	OFF: NULL code output ON: No change	R/W
SM703	Sort order	OFF: Ascending order ON: Descending order	R/W
SM704	Block comparison	OFF: Non-match found ON: All match	R
SM709	DT/TM instruction improper data detection	OFF: Improper data not detected ON: Improper data detected	R/W

FX high-speed input and output

The special relays for FX high-speed input and output are shown below.

R: Read only, R/W: Read/Write

No.	Name	Description	R/W
SM4500	High-speed counter operation (CH1)	OFF: Stopped ON: Operation	R
SM4501	High-speed counter operation (CH2)	OFF: Stopped ON: Operation	R
SM4502	High-speed counter operation (CH3)	OFF: Stopped ON: Operation	R
SM4503	High-speed counter operation (CH4)	OFF: Stopped ON: Operation	R
SM4504	High-speed counter operation (CH5)	OFF: Stopped ON: Operation	R
SM4505	High-speed counter operation (CH6)	OFF: Stopped ON: Operation	R
SM4506	High-speed counter operation (CH7)	OFF: Stopped ON: Operation	R
SM4507	High-speed counter operation (CH8)	OFF: Stopped ON: Operation	R
SM4516	High-speed counter pulse density/Rotation speed measurement (CH1)	OFF: Stopped ON: Measurement	R
SM4517	High-speed counter pulse density/Rotation speed measurement (CH2)	OFF: Stopped ON: Measurement	R
SM4518	High-speed counter pulse density/Rotation speed measurement (CH3)	OFF: Stopped ON: Measurement	R
SM4519	High-speed counter pulse density/Rotation speed measurement (CH4)	OFF: Stopped ON: Measurement	R
SM4520	High-speed counter pulse density/Rotation speed measurement (CH5)	OFF: Stopped ON: Measurement	R

No.	Name	Description	R/W
SM4521	High-speed counter pulse density/Rotation speed measurement (CH6)	OFF: Stopped ON: Measurement	R
SM4522	High-speed counter pulse density/Rotation speed measurement (CH7)	OFF: Stopped ON: Measurement	R
SM4523	High-speed counter pulse density/Rotation speed measurement (CH8)	OFF: Stopped ON: Measurement	R
SM4532	High-speed counter overflow (CH1)	OFF: No error ON: Overflow	R/W
SM4533	High-speed counter overflow (CH2)	OFF: No error ON: Overflow	R/W
SM4534	High-speed counter overflow (CH3)	OFF: No error ON: Overflow	R/W
SM4535	High-speed counter overflow (CH4)	OFF: No error ON: Overflow	R/W
SM4536	High-speed counter overflow (CH5)	OFF: No error ON: Overflow	R/W
SM4537	High-speed counter overflow (CH6)	OFF: No error ON: Overflow	R/W
SM4538	High-speed counter overflow (CH7)	OFF: No error ON: Overflow	R/W
SM4539	High-speed counter overflow (CH8)	OFF: No error ON: Overflow	R/W
SM4548	High-speed counter underflow (CH1)	OFF: No error ON: Underflow	R/W
SM4549	High-speed counter underflow (CH2)	OFF: No error ON: Underflow	R/W
SM4550	High-speed counter underflow (CH3)	OFF: No error ON: Underflow	R/W
SM4551	High-speed counter underflow (CH4)	OFF: No error ON: Underflow	R/W
SM4552	High-speed counter underflow (CH5)	OFF: No error ON: Underflow	R/W
SM4553	High-speed counter underflow (CH6)	OFF: No error ON: Underflow	R/W
SM4554	High-speed counter underflow (CH7)	OFF: No error ON: Underflow	R/W
SM4555	High-speed counter underflow (CH8)	OFF: No error ON: Underflow	R/W
SM4564	High-speed counter count direction monitor (CH1) (1-phase 2-input, 2-phase 2-input)	OFF: Up-counting ON: Down-counting	R
SM4565	High-speed counter count direction monitor (CH2) (1-phase 2-input, 2-phase 2-input)	OFF: Up-counting ON: Down-counting	R
SM4566	High-speed counter count direction monitor (CH3) (1-phase 2-input, 2-phase 2-input)	OFF: Up-counting ON: Down-counting	R
SM4567	High-speed counter count direction monitor (CH4) (1-phase 2-input, 2-phase 2-input)	OFF: Up-counting ON: Down-counting	R
SM4568	High-speed counter count direction monitor (CH5) (1-phase 2-input, 2-phase 2-input)	OFF: Up-counting ON: Down-counting	R
SM4569	High-speed counter count direction monitor (CH6) (1-phase 2-input, 2-phase 2-input)	OFF: Up-counting ON: Down-counting	R
SM4570	High-speed counter count direction monitor (CH7) (1-phase 2-input, 2-phase 2-input)	OFF: Up-counting ON: Down-counting	R
SM4571	High-speed counter count direction monitor (CH8) (1-phase 2-input, 2-phase 2-input)	OFF: Up-counting ON: Down-counting	R
SM4580	High-speed counter count switching (CH1) (1-phase 1-input S/W)	OFF: Up-counting ON: Down-counting	R/W
SM4581	High-speed counter count switching (CH2) (1-phase 1-input S/W)	OFF: Up-counting ON: Down-counting	R/W
SM4582	High-speed counter count switching (CH3) (1-phase 1-input S/W)	OFF: Up-counting ON: Down-counting	R/W

No.	Name	Description	R/W
SM4583	High-speed counter count switching (CH4) (1-phase 1-input S/W)	OFF: Up-counting ON: Down-counting	R/W
SM4584	High-speed counter count switching (CH5) (1-phase 1-input S/W)	OFF: Up-counting ON: Down-counting	R/W
SM4585	High-speed counter count switching (CH6) (1-phase 1-input S/W)	OFF: Up-counting ON: Down-counting	R/W
SM4586	High-speed counter count switching (CH7) (1-phase 1-input S/W)	OFF: Up-counting ON: Down-counting	R/W
SM4587	High-speed counter count switching (CH8) (1-phase 1-input S/W)	OFF: Up-counting ON: Down-counting	R/W
SM4596	High-speed counter preset input logic (CH1)	OFF: Positive logic ON: Negative logic	R/W
SM4597	High-speed counter preset input logic (CH2)	OFF: Positive logic ON: Negative logic	R/W
SM4598	High-speed counter preset input logic (CH3)	OFF: Positive logic ON: Negative logic	R/W
SM4599	High-speed counter preset input logic (CH4)	OFF: Positive logic ON: Negative logic	R/W
SM4600	High-speed counter preset input logic (CH5)	OFF: Positive logic ON: Negative logic	R/W
SM4601	High-speed counter preset input logic (CH6)	OFF: Positive logic ON: Negative logic	R/W
SM4602	High-speed counter preset input logic (CH7)	OFF: Positive logic ON: Negative logic	R/W
SM4603	High-speed counter preset input logic (CH8)	OFF: Positive logic ON: Negative logic	R/W
SM4612	High-speed counter preset input comparison (CH1)	OFF: Disabled ON: Enabled	R/W
SM4613	High-speed counter preset input comparison (CH2)	OFF: Disabled ON: Enabled	R/W
SM4614	High-speed counter preset input comparison (CH3)	OFF: Disabled ON: Enabled	R/W
SM4615	High-speed counter preset input comparison (CH4)	OFF: Disabled ON: Enabled	R/W
SM4616	High-speed counter preset input comparison (CH5)	OFF: Disabled ON: Enabled	R/W
SM4617	High-speed counter preset input comparison (CH6)	OFF: Disabled ON: Enabled	R/W
SM4618	High-speed counter preset input comparison (CH7)	OFF: Disabled ON: Enabled	R/W
SM4619	High-speed counter preset input comparison (CH8)	OFF: Disabled ON: Enabled	R/W
SM4628	High-speed counter enable input logic (CH1)	OFF: Positive logic ON: Negative logic	R/W
SM4629	High-speed counter enable input logic (CH2)	OFF: Positive logic ON: Negative logic	R/W
SM4630	High-speed counter enable input logic (CH3)	OFF: Positive logic ON: Negative logic	R/W
SM4631	High-speed counter enable input logic (CH4)	OFF: Positive logic ON: Negative logic	R/W
SM4632	High-speed counter enable input logic (CH5)	OFF: Positive logic ON: Negative logic	R/W
SM4633	High-speed counter enable input logic (CH6)	OFF: Positive logic ON: Negative logic	R/W
SM4634	High-speed counter enable input logic (CH7)	OFF: Positive logic ON: Negative logic	R/W
SM4635	High-speed counter enable input logic (CH8)	OFF: Positive logic ON: Negative logic	R/W
SM4644	High-speed counter ring length (CH1)	OFF: Disabled ON: Enabled	R/W

No.	Name	Description	R/W
SM4645	High-speed counter ring length (CH2)	OFF: Disabled ON: Enabled	R/W
SM4646	High-speed counter ring length (CH3)	OFF: Disabled ON: Enabled	R/W
SM4647	High-speed counter ring length (CH4)	OFF: Disabled ON: Enabled	R/W
SM4648	High-speed counter ring length (CH5)	OFF: Disabled ON: Enabled	R/W
SM4649	High-speed counter ring length (CH6)	OFF: Disabled ON: Enabled	R/W
SM4650	High-speed counter ring length (CH7)	OFF: Disabled ON: Enabled	R/W
SM4651	High-speed counter ring length (CH8)	OFF: Disabled ON: Enabled	R/W
SM4980	High-speed comparison table (high-speed compare instruction) operation	OFF: Stopped ON: Operation	R
SM4982	High-speed comparison table (high-speed compare instruction) error	OFF: No error ON: Error	R/W
SM5000	Multi-point output high-speed comparison table operation	OFF: Stopped ON: Operation	R
SM5001	Multi-point output high-speed comparison table completion	OFF: Not completed ON: Completion	R/W
SM5020	Pulse width measurement operation (CH1)	OFF: Stopped ON: Operation	R
SM5021	Pulse width measurement operation (CH2)	OFF: Stopped ON: Operation	R
SM5022	Pulse width measurement operation (CH3)	OFF: Stopped ON: Operation	R
SM5023	Pulse width measurement operation (CH4)	OFF: Stopped ON: Operation	R
SM5036	Pulse width measurement rising flag (CH1)	OFF: Cycle measurement not completed ON: Cycle measurement completion	R
SM5037	Pulse width measurement rising flag (CH2)	OFF: Cycle measurement not completed ON: Cycle measurement completion	R
SM5038	Pulse width measurement rising flag (CH3)	OFF: Cycle measurement not completed ON: Cycle measurement completion	R
SM5039	Pulse width measurement rising flag (CH4)	OFF: Cycle measurement not completed ON: Cycle measurement completion	R
SM5052	Pulse width measurement falling flag (CH1)	OFF: Pulse width measurement not completed ON: Pulse width measurement completion	R
SM5053	Pulse width measurement falling flag (CH2)	OFF: Pulse width measurement not completed ON: Pulse width measurement completion	R
SM5054	Pulse width measurement falling flag (CH3)	OFF: Pulse width measurement not completed ON: Pulse width measurement completion	R
SM5055	Pulse width measurement falling flag (CH4)	OFF: Pulse width measurement not completed ON: Pulse width measurement completion	R
SM5068	Pulse width measurement mode (CH1)	OFF: Always measurement mode ON: 1 time measurement mode	R/W
SM5069	Pulse width measurement mode (CH2)	OFF: Always measurement mode ON: 1 time measurement mode	R/W
SM5070	Pulse width measurement mode (CH3)	OFF: Always measurement mode ON: 1 time measurement mode	R/W
SM5071	Pulse width measurement mode (CH4)	OFF: Always measurement mode ON: 1 time measurement mode	R/W
SM5300	PWM function operation (CH1)	OFF: Stopped ON: Operation	R
SM5301	PWM function operation (CH2)	OFF: Stopped ON: Operation	R
SM5302	PWM function operation (CH3)	OFF: Stopped ON: Operation	R

No.	Name	Description	R/W
SM5303	PWM function operation (CH4)	OFF: Stopped ON: Operation	R
SM5500	Built-in positioning instruction activation (axis 1)	OFF: Stopped ON: Operation	R
SM5501	Built-in positioning instruction activation (axis 2)	OFF: Stopped ON: Operation	R
SM5502	Built-in positioning instruction activation (axis 3)	OFF: Stopped ON: Operation	R
SM5503	Built-in positioning instruction activation (axis 4)	OFF: Stopped ON: Operation	R
SM5516	Built-in positioning pulse output monitor (axis 1)	OFF: Stopped ON: Output	R
SM5517	Built-in positioning pulse output monitor (axis 2)	OFF: Stopped ON: Output	R
SM5518	Built-in positioning pulse output monitor (axis 3)	OFF: Stopped ON: Output	R
SM5519	Built-in positioning pulse output monitor (axis 4)	OFF: Stopped ON: Output	R
SM5532	Built-in positioning error (axis 1)	OFF: No error ON: Error	R/W
SM5533	Built-in positioning error (axis 2)	OFF: No error ON: Error	R/W
SM5534	Built-in positioning error (axis 3)	OFF: No error ON: Error	R/W
SM5535	Built-in positioning error (axis 4)	OFF: No error ON: Error	R/W
SM5580	Built-in positioning table shift instructions (axis 1)	OFF: No table shift ON: Table shift start	R/W
SM5581	Built-in positioning table shift instructions (axis 2)	OFF: No table shift ON: Table shift start	R/W
SM5582	Built-in positioning table shift instructions (axis 3)	OFF: No table shift ON: Table shift start	R/W
SM5583	Built-in positioning table shift instructions (axis 4)	OFF: No table shift ON: Table shift start	R/W
SM5596	Built-in positioning remaining distance operation enabled (axis 1)	OFF: Remaining distance operation disabled ON: Remaining distance operation enabled	R/W
SM5597	Built-in positioning remaining distance operation enabled (axis 2)	OFF: Remaining distance operation disabled ON: Remaining distance operation enabled	R/W
SM5598	Built-in positioning remaining distance operation enabled (axis 3)	OFF: Remaining distance operation disabled ON: Remaining distance operation enabled	R/W
SM5599	Built-in positioning remaining distance operation enabled (axis 4)	OFF: Remaining distance operation disabled ON: Remaining distance operation enabled	R/W
SM5612	Built-in positioning remaining distance operation start (axis 1)	OFF: Remaining distance operation standby ON: Remaining distance operation start	R/W
SM5613	Built-in positioning remaining distance operation start (axis 2)	OFF: Remaining distance operation standby ON: Remaining distance operation start	R/W
SM5614	Built-in positioning remaining distance operation start (axis 3)	OFF: Remaining distance operation standby ON: Remaining distance operation start	R/W
SM5615	Built-in positioning remaining distance operation start (axis 4)	OFF: Remaining distance operation standby ON: Remaining distance operation start	R/W
SM5628	Built-in positioning pulse output stop command (axis 1)	OFF: Pulse output is not stopped ON: Pulse output immediate stop	R/W
SM5629	Built-in positioning pulse output stop command (axis 2)	OFF: Pulse output is not stopped ON: Pulse output immediate stop	R/W
SM5630	Built-in positioning pulse output stop command (axis 3)	OFF: Pulse output is not stopped ON: Pulse output immediate stop	R/W
SM5631	Built-in positioning pulse output stop command (axis 4)	OFF: Pulse output is not stopped ON: Pulse output immediate stop	R/W
SM5644	Built-in positioning pulse decelerates stop command (axis 1) (With remaining distance operation)	OFF: Pulse output is not stopped ON: Pulse output decelerates stop	R/W

No.	Name	Description	R/W
SM5645	Built-in positioning pulse decelerates stop command (axis 2) (With remaining distance operation)	OFF: Pulse output is not stopped ON: Pulse output decelerates stop	R/W
SM5646	Built-in positioning pulse decelerates stop command (axis 3) (With remaining distance operation)	OFF: Pulse output is not stopped ON: Pulse output decelerates stop	R/W
SM5647	Built-in positioning pulse decelerates stop command (axis 4) (With remaining distance operation)	OFF: Pulse output is not stopped ON: Pulse output decelerates stop	R/W
SM5660	Built-in positioning forward rotation limit (axis 1)	OFF: Forward rotation limit OFF ON: Forward rotation limit ON	R/W
SM5661	Built-in positioning forward rotation limit (axis 2)	OFF: Forward rotation limit OFF ON: Forward rotation limit ON	R/W
SM5662	Built-in positioning forward rotation limit (axis 3)	OFF: Forward rotation limit OFF ON: Forward rotation limit ON	R/W
SM5663	Built-in positioning forward rotation limit (axis 4)	OFF: Forward rotation limit OFF ON: Forward rotation limit ON	R/W
SM5676	Built-in positioning reverse rotation limit (axis 1)	OFF: Reverse rotation limit OFF ON: Reverse rotation limit ON	R/W
SM5677	Built-in positioning reverse rotation limit (axis 2)	OFF: Reverse rotation limit OFF ON: Reverse rotation limit ON	R/W
SM5678	Built-in positioning reverse rotation limit (axis 3)	OFF: Reverse rotation limit OFF ON: Reverse rotation limit ON	R/W
SM5679	Built-in positioning reverse rotation limit (axis 4)	OFF: Reverse rotation limit OFF ON: Reverse rotation limit ON	R/W
SM5772	Built-in positioning rotational direction (axis 1)	OFF: Forward rotation (Current address increases) ON: Reverse rotation (Current address increases)	R/W
SM5773	Built-in positioning rotational direction (axis 2)	OFF: Forward rotation (Current address increases) ON: Reverse rotation (Current address increases)	R/W
SM5774	Built-in positioning rotational direction (axis 3)	OFF: Forward rotation (Current address increases) ON: Reverse rotation (Current address increases)	R/W
SM5775	Built-in positioning rotational direction (axis 4)	OFF: Forward rotation (Current address increases) ON: Reverse rotation (Current address increases)	R/W
SM5804	Built-in positioning zero return direction (axis 1)	OFF: Zero return start (Reverse rotation direction) ON: Zero return start (Forward rotation direction)	R/W
SM5805	Built-in positioning zero return direction (axis 2)	OFF: Zero return start (Reverse rotation direction) ON: Zero return start (Forward rotation direction)	R/W
SM5806	Built-in positioning zero return direction (axis 3)	OFF: Zero return start (Reverse rotation direction) ON: Zero return start (Forward rotation direction)	R/W
SM5807	Built-in positioning zero return direction (axis 4)	OFF: Zero return start (Reverse rotation direction) ON: Zero return start (Forward rotation direction)	R/W
SM5820	Built-in positioning clear signal function (axis 1)	OFF: Clear signal disabled ON: Clear signal enabled	R/W
SM5821	Built-in positioning clear signal function (axis 2)	OFF: Clear signal disabled ON: Clear signal enabled	R/W
SM5822	Built-in positioning clear signal function (axis 3)	OFF: Clear signal disabled ON: Clear signal enabled	R/W
SM5823	Built-in positioning clear signal function (axis 4)	OFF: Clear signal disabled ON: Clear signal enabled	R/W
SM5868	Built-in positioning zero-point signal count start (axis 1)	OFF: Near point DOG backward end ON: Near point DOG forward end	R/W
SM5869	Built-in positioning zero-point signal count start (axis 2)	OFF: Near point DOG backward end ON: Near point DOG forward end	R/W
SM5870	Built-in positioning zero-point signal count start (axis 3)	OFF: Near point DOG backward end ON: Near point DOG forward end	R/W
SM5871	Built-in positioning zero-point signal count start (axis 4)	OFF: Near point DOG backward end ON: Near point DOG forward end	R/W

Built-in analog

The special relays for built-in analog are shown below.

R: Read only, R/W: Read/Write

No.	Name	Description	R/W
SM6020	CH1 A/D conversion completed flag	OFF: A/D conversion not completed ON: A/D conversion completed	R
SM6021	CH1 A/D conversion enable/disable setting	OFF: A/D conversion enable ON: A/D conversion disable	R/W
SM6022	CH1 Over scaling detection flag	OFF: No over scaling ON: Over Scaling	R
SM6024	CH1 Over scaling over detection setting	OFF: Enable ON: Disable	R/W
SM6025	CH1 Maximum value/minimum value reset completed flag	OFF: Reset not completed ON: Reset completed	R
SM6026	CH1 Maximum value reset request	OFF: No reset request ON: Reset request	R
SM6027	CH1 Minimum value reset request	OFF: No reset request ON: Reset request	R
SM6028	CH1 A/D scaling enable/disable setting	OFF: Enable ON: Disable	R/W
SM6029	CH1 Digital clipping enable/disable setting	OFF: Enable ON: Disable	R/W
SM6031	CH1 Warning output flag (Process alarm upper limit)	OFF: No alarm ON: Alarm	R
SM6032	CH1 Warning output flag (Process alarm lower limit)	OFF: No alarm ON: Alarm	R
SM6033	CH1 Warning output setting (Process alarm)	OFF: Enabled ON: Disabled	R/W
SM6057	CH1 A/D alarm clear request	OFF: No clear request ON: Clear request	R/W
SM6058	CH1 A/D alarm flag	OFF: No alarm ON: Alarm	R
SM6059	CH1 A/D error flag	OFF: No error ON: Error	R
SM6060	CH2 A/D conversion completed flag	OFF: A/D conversion not completed ON: A/D conversion completed	R
SM6061	CH2 A/D conversion enable/disable setting	OFF: A/D conversion enable ON: A/D conversion disable	R/W
SM6062	CH2 Over scaling detection flag	OFF: No over scaling ON: Over scaling	R
SM6064	CH2 Over scaling over detection	OFF: Enable ON: Disable	R/W
SM6065	CH2 Maximum value/minimum value reset completed flag	OFF: Reset not completed ON: Reset completed	R
SM6066	CH2 Maximum value reset request	OFF: No reset request ON: Reset request	R
SM6067	CH2 Minimum value reset request	OFF: No reset request ON: Reset request	R
SM6068	CH2 A/D scaling enable/disable setting	OFF: Enable ON: Disable	R/W
SM6069	CH2 Digital clipping enable/disable setting	OFF: Enable ON: Disable	R/W
SM6071	CH2 Warning output flag (Process alarm upper limit)	OFF: No alarm ON: Alarm	R
SM6072	CH2 Warning output flag (Process alarm lower limit)	OFF: No alarm ON: Alarm	R
SM6073	CH2 Warning output setting (Process alarm)	OFF: Enabled ON: Disabled	R/W
SM6097	CH2 A/D alarm clear request	OFF: No clear request ON: Clear request	R/W

No.	Name	Description	R/W
SM6098	CH2 A/D alarm flag	OFF: No alarm ON: Alarm	R/W
SM6099	CH2 A/D error flag	OFF: No error ON: Error	R/W
SM6180	D/A conversion enable/disable setting	OFF: D/A conversion enable ON: D/A conversion disable	R/W
SM6181	D/A output enable/disable	OFF: Output enable ON: Output disable	R/W
SM6188	Scaling enable/disable setting	OFF: Enable ON: Disable	R/W
SM6191	Warning output upper limit value flag	OFF: No alarm ON: Alarm	R
SM6192	Warning output lower limit value flag	OFF: No alarm ON: Alarm	R
SM6193	Warning output setting	OFF: Disabled ON: Enabled	R/W
SM6217	D/A alarm clear request	OFF: No clear request ON: Clear request	R/W
SM6218	D/A alarm flag	OFF: No alarm ON: Alarm	R
SM6219	D/A error flag	OFF: No error ON: Error	R

FX compatible area

The special relays of FX compatible area are shown below.

R: Read only, R/W: Read/Write

No.	Name	Description	R/W
SM8000	RUN monitor NO contact	OFF: STOP ON: RUN	R
SM8001	RUN monitor NC contact	OFF: RUN ON: STOP	R
SM8002	Initial pulse NO contact	OFF: SM8002 turns off except during 1 scan at the time of RUN ON: SM8002 turns on during 1 scan at the time of RUN	R
SM8003	Initial pulse NC contact	OFF: SM8003 turns on during 1 scan at the time of RUN ON: SM8003 turns off except during 1 scan at the time of RUN	R
SM8004	Error occurrence	OFF: No error ON: Error	R
SM8005	Battery voltage low	OFF: Battery normal ON: Battery voltage low	R
SM8006	Battery error latch	OFF: Battery normal ON: Battery voltage low latch	R
SM8007	Momentary power failure	OFF: No momentary power failure ON: Momentary power failure detected	R
SM8008	Power failure detected	OFF: No momentary power failure ON: During momentary power failure	R
SM8011	10 msec clock pulse	ON and OFF in 10 ms cycles OFF: 5 ms ON: 5 ms	R
SM8012	100 msec clock pulse	ON and OFF in 100 ms cycles OFF: 50 ms ON: 50 ms	R
SM8013	1 sec clock pulse	ON and OFF in 1 sec cycles OFF: 500 ms ON: 500 ms	R
SM8014	1 min clock pulse	ON and OFF in 1 min cycles OFF: 30 s ON: 30 s	R
SM8015	Clock stop and preset	When SM8015 turns ON, the real time clock is stopped. At the edge from ON to OFF, the time from SD8013 to SD8019 is written to the PLC and the clock is started again.	R/W

No.	Name	Description	R/W
SM8016	Time read display is stopped	When SM8016 turns ON, the time display is stopped.	R/W
SM8017	±30 seconds correction	At the edge from OFF to ON, the RTC is set to the nearest minute. (When the second data is from 0 to 29, it is set to 0. When the second data is from 30 to 59, it is set to 0 and the minute data is incremented by "1".)	R/W
SM8019	Real time clock error	When the data stored in special registers is outside the allowable time setting range, this device turns ON.	R
SM8020	Zero	OFF: Zero flag OFF ON: Zero flag ON	R
SM8021	Borrow	OFF: Borrow flag OFF ON: Borrow flag ON	R
SM8022	Carry	OFF: Carry flag OFF ON: Carry flag ON	R
SM8023	Real time clock access error	SM8023 turns ON at the time of RTC access (reading/writing) error occurrence.	R
SM8026	RAMP mode	OFF: Standard mode ON: RAMP mode	R
SM8029	Instruction execution complete	OFF: Instruction execution not complete ON: Instruction execution complete	R
SM8031	Non-latch memory all clear	OFF: No clear ON: Non-latch memory all clear	R
SM8032	Latch memory all clear	OFF: No clear ON: Latch memory all clear	R
SM8033	Memory hold stop	OFF: Clear ON: Hold	R
SM8034	All output disable	OFF: Normal operation ON: All output disable	R
SM8039	Constant scan mode	OFF: Normal operation ON: Constant scan mode	R/W
SM8040	STL transfer disable	OFF: Normal operation ON: Transfer disable	R/W
SM8041	Transfer start	Transfer from initial state is enabled in automatic operation mode	R
SM8042	Start pulse	Pulse output is given in response to a start input	R
SM8043	Zero return complete	Set this in the last state of zero return mode	R/W
SM8044	Zero point condition	Set this when machine zero return is detected	R/W
SM8045	All output reset disable	Disables the 'all output reset' function when the operation mode is changed	R/W
SM8046	STL state ON	ON when SM8047 is ON and any state (S) is active	R/W
SM8047	Enable STL monitoring	SD8040 to SD8047 are enabled when SM8047 is ON	R/W
SM8048	Annunciator ON	ON when SM8049 is ON and any state (S900 to S999) is ON.	R/W
SM8049	Enable annunciator monitoring	SD8049 is enabled when SM8049 is ON.	R/W
SM8050	I00□ disable	OFF: Interrupt enabled ON: Interrupt disabled	R/W
SM8051	I10□ disable	OFF: Interrupt enabled ON: Interrupt disabled	R/W
SM8052	I20□ disable	OFF: Interrupt enabled ON: Interrupt disabled	R/W
SM8053	I30□ disable	OFF: Interrupt enabled ON: Interrupt disabled	R/W
SM8054	I40□ disable	OFF: Interrupt enabled ON: Interrupt disabled	R/W
SM8055	I50□ disable	OFF: Interrupt enabled ON: Interrupt disabled	R/W
SM8056	I60□ disable	OFF: Interrupt enabled ON: Interrupt disabled	R/W
SM8057	I70□ disable	OFF: Interrupt enabled ON: Interrupt disabled	R/W
SM8058	I80□ disable	OFF: Interrupt enabled ON: Interrupt disabled	R/W

No.	Name	Description	R/W
SM8059	I/O disable (Counter interrupt disable)	OFF: Interrupt enabled ON: Interrupt disabled	R/W
SM8063	Serial communication error1 (ch1)	OFF: No error ON: Error	R
SM8067	Operation error	OFF: No error ON: Error	R
SM8068	Operation error latch	OFF: No error ON: Error (latch)	R
SM8090	Block comparison signal	Block comparison signal ON when all comparison results are ON.	R
SM8099	High-speed ring counter	OFF: High-speed ring counter stop ON: High-speed ring counter start	R/W
SM8151	Inverter communication (ch1)	ON during inverter communication.	R
SM8152	Inverter communication error (ch1)	OFF: No error ON: Error	R
SM8153	Inverter communication error latch (ch1)	OFF: No error ON: Error (latch)	R
SM8154	IVBWR instruction error (ch1)	OFF: No error ON: Error	R
SM8156	Inverter communication (ch2)	ON during inverter communication.	R
SM8157	Inverter communication error (ch2)	OFF: No error ON: Error	R
SM8158	Inverter communication error latch (ch2)	OFF: No error ON: Error (latch)	R
SM8159	IVBWR instruction error (ch2)	OFF: No error ON: Error	R
SM8161	8 bit operation mode	OFF: 16 bit operation mode ON: 8 bit operation mode	R/W
SM8168	SMOV data mode	BIN→BCD conversion will not be performed, if a SMOV instruction is executed after turning on SM8168.	R/W
SM8170	X000 pulse catch	Pulse catch ON when X000 is OFF→ON	R/W
SM8171	X001 pulse catch	Pulse catch ON when X001 is OFF→ON	R/W
SM8172	X002 pulse catch	Pulse catch ON when X002 is OFF→ON	R/W
SM8173	X003 pulse catch	Pulse catch ON when X003 is OFF→ON	R/W
SM8174	X004 pulse catch	Pulse catch ON when X004 is OFF→ON	R/W
SM8175	X005 pulse catch	Pulse catch ON when X005 is OFF→ON.	R/W
SM8176	X006 pulse catch	Pulse catch ON when X006 is OFF→ON.	R/W
SM8177	X007 pulse catch	Pulse catch ON when X007 is OFF→ON.	R/W
SM8183	Data communication error (Master station)	OFF: No error ON: Error	R
SM8184	Data communication error (Slave station No.1)	OFF: No error ON: Error	R
SM8185	Data communication error (Slave station No.2)	OFF: No error ON: Error	R
SM8186	Data communication error (Slave station No.3)	OFF: No error ON: Error	R
SM8187	Data communication error (Slave station No.4)	OFF: No error ON: Error	R
SM8188	Data communication error (Slave station No.5)	OFF: No error ON: Error	R
SM8189	Data communication error (Slave station No.6)	OFF: No error ON: Error	R
SM8190	Data communication error (Slave station No.7)	OFF: No error ON: Error	R
SM8191	Data communication in execution	OFF: Data communication in execution ON: Data communication in nonexecution	R
SM8246	LC46 counting direction monitoring	OFF: Down count operation ON: Up count operation	R
SM8247	LC47 counting direction monitoring	OFF: Down count operation ON: Up count operation	R

No.	Name	Description	R/W
SM8248	LC48 counting direction monitoring	OFF: Down count operation ON: Up count operation	R
SM8249	LC49 counting direction monitoring	OFF: Down count operation ON: Up count operation	R
SM8250	LC50 counting direction monitoring	OFF: Down count operation ON: Up count operation	R
SM8251	LC51 counting direction monitoring	OFF: Down count operation ON: Up count operation	R
SM8252	LC52 counting direction monitoring	OFF: Down count operation ON: Up count operation	R
SM8253	LC53 counting direction monitoring	OFF: Down count operation ON: Up count operation	R
SM8254	LC54 counting direction monitoring	OFF: Down count operation ON: Up count operation	R
SM8255	LC55 counting direction monitoring	OFF: Down count operation ON: Up count operation	R
SM8304	Zero	OFF: Zero flag OFF ON: Zero flag ON	R
SM8306	Carry	OFF: Carry flag OFF ON: Carry flag ON	R
SM8329	Instruction execution error	OFF: Instruction execution normal ON: Instruction execution error complete	R
SM8330	Timing clock output 1	DUTY instruction: Timing clock output 1	R
SM8331	Timing clock output 2	DUTY instruction: Timing clock output 2	R
SM8332	Timing clock output 3	DUTY instruction: Timing clock output 3	R
SM8333	Timing clock output 4	DUTY instruction: Timing clock output 4	R
SM8334	Timing clock output 5	DUTY instruction: Timing clock output 5	R
SM8340	Axis 1 pulse output monitor	OFF: Stopped ON: Pulse output	R
SM8348	Axis 1 positioning instruction executing	OFF: Positioning instruction not executing ON: Positioning instruction executing	R
SM8350	Axis 2 pulse output monitor	OFF: Stopped ON: Output	R
SM8358	Axis 2 positioning instruction executing	OFF: Positioning instruction not executing ON: Positioning instruction executing	R
SM8360	Axis 3 pulse output monitor	OFF: Stopped ON: Output	R
SM8368	Axis 3 positioning instruction executing	OFF: Positioning instruction not executing ON: Positioning instruction executing	R
SM8370	Axis 4 pulse output monitor	OFF: Stopped ON: Output	R
SM8378	Axis 4 positioning instruction executing	OFF: Positioning instruction not executing ON: Positioning instruction executing	R
SM8401	RS2 Send wait flag (ch1)/MODBUS request in process (ch1)	ON during send wait or MODBUS communication.	R
SM8402	MODBUS communication error (ch1)	OFF: No error ON: Error	R
SM8403	MODBUS communication error (latched) (ch1)	OFF: No error ON: Error (latch)	R
SM8404	RS2 Carrier detection flag (ch1)/MODBUS communication mode (ch1)	ON when carrier detection or listen only mode	R
SM8405	RS2 Data set ready (DSR) flag (ch1)	OFF: DSR not detected ON: DSR detected	R
SM8408	MODBUS retry (ch1)	OFF: Not retry ON: Retry	R
SM8409	RS2 Time-out check flag (ch1)/MODBUS Timeout (ch1)	ON when time-out occurs.	R
SM8421	RS2 Send wait flag (ch2)/MODBUS request in process (ch2)	ON during send wait or MODBUS communication	R
SM8422	MODBUS communication error (ch2)	OFF: No error ON: Error	R

No.	Name	Description	R/W
SM8423	MODBUS communication error (latched) (ch2)	OFF: No error ON: Error (latch)	R
SM8424	RS2 Carrier detection flag (ch2)/MODBUS communication mode (ch2)	Carrier detection flag or listen only mode ON when operating.	R
SM8425	RS2 Data set ready (DSR) flag (ch2)	OFF: DSR not detected ON: DSR detected	R
SM8428	MODBUS retry (ch2)	OFF: No retry ON: Retry	R
SM8429	RS2 Time-out check flag (ch2)/MODBUS Timeout (ch2)	ON when timeout occurs.	R
SM8438	Serial communication error 2 (ch2)	OFF: No error ON: Error	R
SM8492	IP address storage area write request	If OFF to ON, the IP address setting stored in SD8492 to SD8497 will be written in the IP address storage area.	R/W
SM8493	IP address storage area write completed	<ul style="list-style-type: none"> It turns on, if the write to the IP address storage area is completed. Moreover, it turns on also at the time of the write-in failure. Turns OFF when IP address storage area write request (SM8492) turns from ON to OFF. 	R
SM8494	IP address storage area write error	<ul style="list-style-type: none"> Turns ON when writing to IP address storage area is failed. Turns ON if there is a problem in contents of IP address storage area, when PLC power supply is turned from OFF to ON. Turns OFF when IP address storage area write request (SM8492) turns from ON to OFF. 	R
SM8495	IP address storage area clear request	Contents of IP address storage area are cleared when this device turns from OFF to ON.	R/W
SM8496	IP address storage area clear completed	<ul style="list-style-type: none"> It turns on, if the clear to the IP address storage area is completed. Moreover, it turns on also at the time of the clear-in failure. Turns OFF when IP address storage area clear request (SM8495) turns from ON to OFF. 	R
SM8497	IP address storage area clear error	<ul style="list-style-type: none"> Turns ON when clear to IP address storage area is failed. Turns OFF when IP address storage area clear request (SM8495) turns from ON to OFF. 	R
SM8498	IP address change function enable flag	Turns ON when IP address is changed by IP address change function.	R

Serial communication

The special relays for serial communication are shown below.

R: Read only, R/W: Read/Write

No.	Name	Description	R/W
SM8500	Serial communication error (ch1)	OFF: No error ON: Error	R
SM8510	Serial communication error (ch2)	OFF: No error ON: Error	R
SM8520	Serial communication error (ch3)	OFF: No error ON: Error	R
SM8530	Serial communication error (ch4)	OFF: No error ON: Error	R
SM8560	Data transfer delayed (ch1)	This device remains ON while the PLC is waiting to send.	R
SM8561	Data transfer flag (ch1)	When this device is set to ON, the PLC starts to send.	R
SM8562	Receive completion flag (ch1)	This device turns ON when receiving is completed.	R
SM8563	Carrier detection flag (ch1)	This device turns ON in synchronization with the CD (DCD) signal.	R
SM8564	Data set ready flag (ch1)	This device turns ON in synchronization with the DR (DSR) signal.	R
SM8565	Time-out check flag (ch1)	This device turns ON when data receiving is suspended and the next set of receive data is not given within the time set by the time-out time setting device.	R
SM8570	Data transfer delayed (ch2)	This device remains ON while the PLC is waiting to send.	R
SM8571	Data transfer flag (ch2)	When this device is set to ON, the PLC starts to send.	R
SM8572	Receive completion flag (ch2)	This device turns ON when receiving is completed.	R

No.	Name	Description	R/W
SM8573	Carrier detection flag (ch2)	This device turns ON in synchronization with the CD (DCD) signal.	R
SM8574	Data set ready flag (ch2)	This device turns ON in synchronization with the DR (DSR) signal.	R
SM8575	Time-out check flag (ch2)	This device turns ON when data receiving is suspended and the next set of receive data is not given within the time set by the time-out time setting device.	R
SM8580	Data transfer delayed (ch3)	This device remains ON while the PLC is waiting to send.	R
SM8581	Data transfer flag (ch3)	When this device is set to ON, the PLC starts to send.	R
SM8582	Receive completion flag (ch3)	This device turns ON when receiving is completed.	R
SM8583	Carrier detection flag (ch3)	This device turns ON in synchronization with the CD (DCD) signal.	R
SM8584	Data set ready flag (ch3)	This device turns ON in synchronization with the DR (DSR) signal.	R
SM8585	Time-out check flag (ch3)	This device turns ON when data receiving is suspended and the next set of receive data is not given within the time set by the time-out time setting device.	R
SM8590	Data transfer delayed (ch4)	This device remains ON while the PLC is waiting to send	R
SM8591	Data transfer flag (ch4)	When this device is set to ON, the PLC starts to send	R
SM8592	Receive completion flag (ch4)	This device turns ON when receiving is completed	R
SM8593	Carrier detection flag (ch4)	This device turns ON in synchronization with the CD (DCD) signal	R
SM8594	Data set ready flag (ch4)	This device turns ON in synchronization with the DR (DSR) signal	R
SM8595	Time-out check flag (ch4)	This device turns ON when data receiving is suspended and the next set of receive data is not given within the time set by the time-out time setting device	R
SM8740	Station No. setting SD latch enabled (ch1)	OFF: Latch disabled ON: Latch enabled	R
SM8750	Station No. setting SD latch enabled (ch2)	OFF: Latch disabled ON: Latch enabled	R
SM8760	Station No. setting SD latch enabled (ch3)	OFF: Latch disabled ON: Latch enabled	R
SM8770	Station No. setting SD latch enabled (ch4)	OFF: Latch disabled ON: Latch enabled	R
SM8800	MODBUS RTU communication (ch1)	OFF: Communication stop ON: Communication	R
SM8801	Retry (ch1)	OFF: No retry ON: Retry	R
SM8802	Timeout (ch1)	OFF: No timeout ON: Timeout	R
SM8810	MODBUS RTU communication (ch2)	OFF: Communication stop ON: Communication	R
SM8811	Retry (ch2)	OFF: No retry ON: Retry	R
SM8812	Timeout (ch2)	OFF: Not timeout ON: Timeout	R
SM8820	MODBUS RTU communication (ch3)	OFF: Communication stop ON: Communication	R
SM8821	Retry (ch3)	OFF: No retry ON: Retry	R
SM8822	Timeout (ch3)	OFF: No timeout ON: Timeout	R
SM8830	MODBUS RTU communication (ch4)	OFF: Communication stop ON: Communication	R
SM8831	Retry (ch4)	OFF: No retry ON: Retry	R
SM8832	Timeout (ch4)	OFF: No timeout ON: Timeout	R
SM8861	Host station No. setting SD latch enabled (ch1)	OFF: Latch disabled ON: Latch enabled	R
SM8871	Host station No. setting SD latch enabled (ch2)	OFF: Latch disabled ON: Latch enabled	R
SM8881	Host station No. setting SD latch enabled (ch3)	OFF: Latch disabled ON: Latch enabled	R

No.	Name	Description	R/W
SM8891	Host station No. setting SD latch enabled (ch4)	OFF: Latch disabled ON: Latch enabled	R
SM8920	Inverter communication (ch1)	OFF: No communication ON: Communication	R
SM8921	IVBWR instruction error (ch1)	OFF: No error ON: Error	R
SM8930	Inverter communication (ch2)	OFF: No communication ON: Communication	R
SM8931	IVBWR instruction error (ch2)	OFF: No error ON: Error	R
SM8940	Inverter communication (ch3)	OFF: No communication ON: Communication	R
SM8941	IVBWR instruction error (ch3)	OFF: No error ON: Error	R
SM8950	Inverter communication (ch4)	OFF: No communication ON: Communication	R
SM8951	IVBWR instruction error (ch4)	OFF: No error ON: Error	R
SM9040	Data communication error (Master station)	OFF: No error ON: Error	R
SM9041	Data communication error (Slave station No.1)	OFF: No error ON: Error	R
SM9042	Data communication error (Slave station No.2)	OFF: No error ON: Error	R
SM9043	Data communication error (Slave station No.3)	OFF: No error ON: Error	R
SM9044	Data communication error (Slave station No.4)	OFF: No error ON: Error	R
SM9045	Data communication error (Slave station No.5)	OFF: No error ON: Error	R
SM9046	Data communication error (Slave station No.6)	OFF: No error ON: Error	R
SM9047	Data communication error (Slave station No.7)	OFF: No error ON: Error	R
SM9056	Data communication in execution	OFF: Data communication in execution ON: Data communication in nonexecution	R
SM9080	Station No. setting SD latch enabled	OFF: Latch disabled ON: Latch enabled	R
SM9081	Slave station total number setting SD latch enabled	OFF: Latch disabled ON: Latch enabled	R

Appendix 2 Special Register List

Diagnostic information

The special register for diagnostic information are shown below.

R: Read only, R/W: Read/Write

No.	Name	Description	R/W				
SD0	Latest self diagnostics error code	This register stores the latest self-diagnosis error code.	R				
SD1	Clock time for self diagnosis error occurrence (Year)	This register stores the latest self-diagnosis error time (Year).	R				
SD2	Clock time for self diagnosis error occurrence (Month)	This register stores the latest self-diagnosis error time (Month).	R				
SD3	Clock time for self diagnosis error occurrence (Day)	This register stores the latest self-diagnosis error time (Day).	R				
SD4	Clock time for self diagnosis error occurrence (Hour)	This register stores the latest self-diagnosis error time (Hour).	R				
SD5	Clock time for self diagnosis error occurrence (Minute)	This register stores the latest self-diagnosis error time (Minute).	R				
SD6	Clock time for self diagnosis error occurrence (Second)	This register stores the latest self-diagnosis error time (Second).	R				
SD7	Clock time for self diagnosis error occurrence (Day Week)	This register stores the latest self-diagnosis error time (Day Week).	R				
SD10	Self diagnostics error code 1	This register stores the self-diagnosis error code.	R				
SD11	Self diagnostics error code 2	This register stores the self-diagnosis error code.	R				
SD12	Self diagnostics error code 3	This register stores the self-diagnosis error code.	R				
SD13	Self diagnostics error code 4	This register stores the self-diagnosis error code.	R				
SD14	Self diagnostics error code 5	This register stores the self-diagnosis error code.	R				
SD15	Self diagnostics error code 6	This register stores the self-diagnosis error code.	R				
SD16	Self diagnostics error code 7	This register stores the self-diagnosis error code.	R				
SD17	Self diagnostics error code 8	This register stores the self-diagnosis error code.	R				
SD18	Self diagnostics error code 9	This register stores the self-diagnosis error code.	R				
SD19	Self diagnostics error code 10	This register stores the self-diagnosis error code.	R				
SD20	Self diagnostics error code 11	This register stores the self-diagnosis error code.	R				
SD21	Self diagnostics error code 12	This register stores the self-diagnosis error code.	R				
SD22	Self diagnostics error code 13	This register stores the self-diagnosis error code.	R				
SD23	Self diagnostics error code 14	This register stores the self-diagnosis error code.	R				
SD24	Self diagnostics error code 15	This register stores the self-diagnosis error code.	R				
SD25	Self diagnostics error code 16	This register stores the self-diagnosis error code.	R				
SD53	The number of AC/DC DOWN detections	This register stores the number of times of momentary power failure.	R				
SD61	I/O Module Verify Error Module No.	This register stores the I/O module verify error module No..	R				
SD62	Annunciator (F) Detection No.	This register stores the earliest detected annunciator (F) No..	R				
SD63	Annunciator (F) Detection Number	This register stores the number of annunciator (F) detections.	R				
SD64 to SD79	Annunciator (F) Detection No. table	This register stores the annunciator (F) detection No.	R				
SD80	Detailed information 1 information category	<ul style="list-style-type: none"> Detailed information 1 information category code is stored. <div style="border: 1px solid black; padding: 5px; margin: 5px 0;"> <table style="width: 100%; border-collapse: collapse;"> <tr> <td style="text-align: center; border-right: 1px solid black;">b15 to b8</td> <td style="text-align: center;">b7 to b0</td> </tr> <tr> <td style="text-align: center; border-right: 1px solid black;">Not used (fixed to 0)</td> <td style="text-align: center;">Information category code</td> </tr> </table> </div> <ul style="list-style-type: none"> The following codes are stored into the information category code. 0: N/A 1: Program position information 2: Drive number and file name 4: Parameter information 5: System configuration information 6: Number of times information 7: Time information 	b15 to b8	b7 to b0	Not used (fixed to 0)	Information category code	R
b15 to b8	b7 to b0						
Not used (fixed to 0)	Information category code						

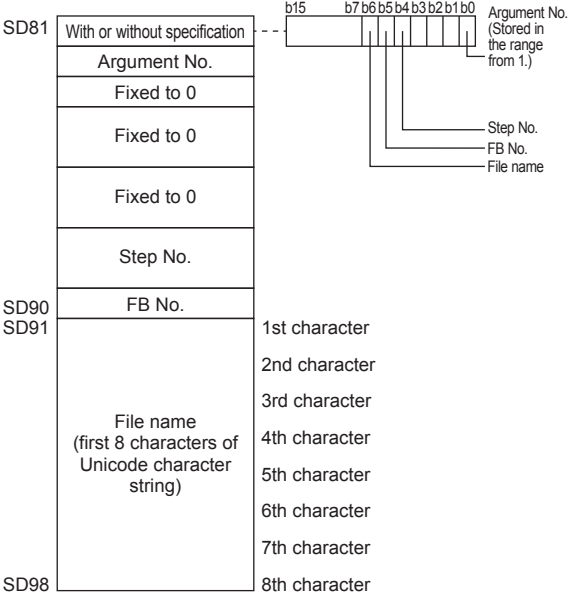
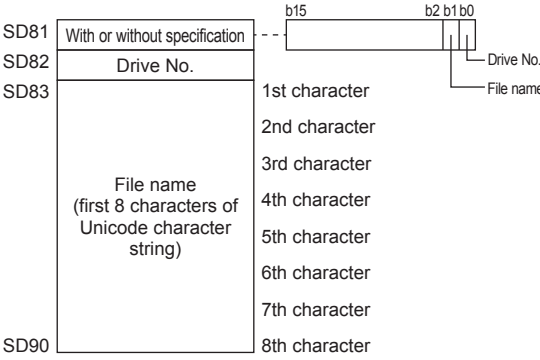
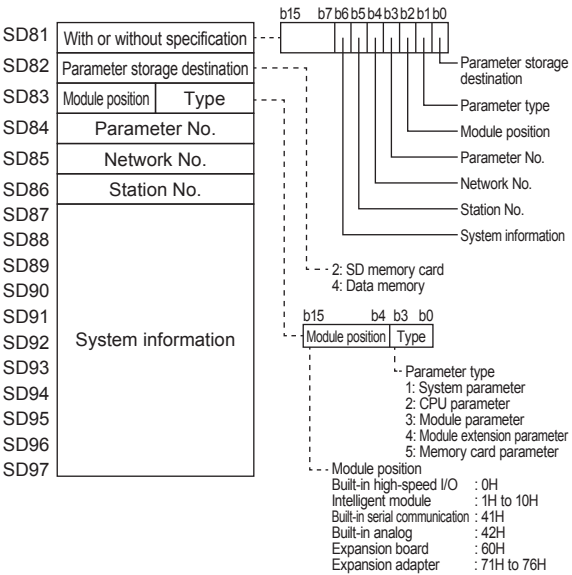
No.	Name	Description	R/W
SD81 to SD111	Detailed information 1	<ul style="list-style-type: none"> Detailed information 1 corresponding to the error code (SD0) is stored. There are six types of information to be stored as shown in the following figures. The type of detailed information 1 can be obtained using SD80 (the value of the "Detailed information 1 information category code" stored in SD80 corresponds to the following figures (1), (2), (4) to (7)). <p>(1) Program location information</p>  <p>(2) Drive number and file name</p>  <p>(4) Parameter information</p>  <p>SD81 With or without specification</p> <p>SD82 Argument No.</p> <p>SD83 Fixed to 0</p> <p>SD84 Fixed to 0</p> <p>SD85 Fixed to 0</p> <p>SD86 Step No.</p> <p>SD87 FB No.</p> <p>SD88 File name</p> <p>SD89 1st character</p> <p>SD90 2nd character</p> <p>SD91 3rd character</p> <p>SD92 4th character</p> <p>SD93 5th character</p> <p>SD94 6th character</p> <p>SD95 7th character</p> <p>SD96 8th character</p> <p>SD97 File name (first 8 characters of Unicode character string)</p> <p>SD81 With or without specification</p> <p>SD82 Drive No.</p> <p>SD83 1st character</p> <p>SD84 2nd character</p> <p>SD85 3rd character</p> <p>SD86 4th character</p> <p>SD87 5th character</p> <p>SD88 6th character</p> <p>SD89 7th character</p> <p>SD90 8th character</p> <p>SD91 File name (first 8 characters of Unicode character string)</p> <p>SD81 With or without specification</p> <p>SD82 Parameter storage destination</p> <p>SD83 Module position Type</p> <p>SD84 Parameter No.</p> <p>SD85 Network No.</p> <p>SD86 Station No.</p> <p>SD87 System information</p> <p>SD88</p> <p>SD89</p> <p>SD90</p> <p>SD91 System information</p> <p>SD92</p> <p>SD93</p> <p>SD94</p> <p>SD95</p> <p>SD96</p> <p>SD97</p> <p>-- 2: SD memory card 4: Data memory</p> <p>-- 1: System parameter 2: CPU parameter 3: Module parameter 4: Module extension parameter 5: Memory card parameter</p> <p>-- Module position Built-in high-speed I/O : 0H Intelligent module : 1H to 10H Built-in serial communication : 41H Built-in analog : 42H Expansion board : 60H Expansion adapter : 71H to 76H</p>	R

No.	Name	Description	R/W
SD81 to SD111	Detailed information 1	<p>(5) System configuration information</p> <p>SD81 With or without specification</p> <p>SD82 Head Y No. ÷ 8 Head X No. ÷ 8</p> <p>SD83 Function No. Module position</p> <p>SD84 Free (Fixed to 0) Intelligent module No.</p> <p>SD85 Network No.</p> <p>SD86 Station No.</p> <p>Legend:</p> <ul style="list-style-type: none"> Module position Built-in high-speed I/O : 0H Built-in serial communication : 41H Built-in analog : 42H Expansion board : 60H Expansion adapter : 71H to 76H Function No. System/Sequence operation : 0 Built-in A/D : 1 Built-in D/A : 2 Built-in positioning, PWM : 10 Built-in high-speed counter, Pulse width measurement: 20 Built-in serial communication : 30 <p>--- Either XY head No. or intelligent module No. is set.</p> <p>(6) Number of times information</p> <p>SD81 With or without specification</p> <p>Number of times (set value) L H</p> <p>SD85 Number of times (actual measurement value) L H</p> <p>(7) Time information</p> <p>SD91 With or without specification</p> <p>SD92 Time (set value) (ms)</p> <p>SD93 Time (set value) (μs)</p> <p>SD94 Time (actual measurement value) (ms)</p> <p>SD95 Time (actual measurement value) (μs)</p>	R
SD112	Detailed information 2 information category	<ul style="list-style-type: none"> Detailed information 2 information category code is stored. <p>b15 to b8 b7 to b0</p> <p>Not used (fixed to 0) Information category code</p> <ul style="list-style-type: none"> The following codes are stored into the information category code. 0: N/A 1: Program position information 2: Drive number and file name 3: Annunciator number 4: Parameter information 5: System configuration information 	R

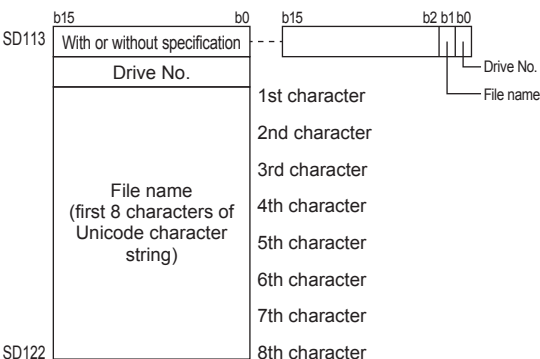
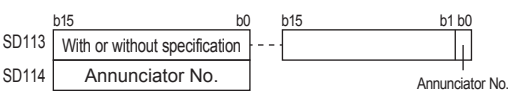
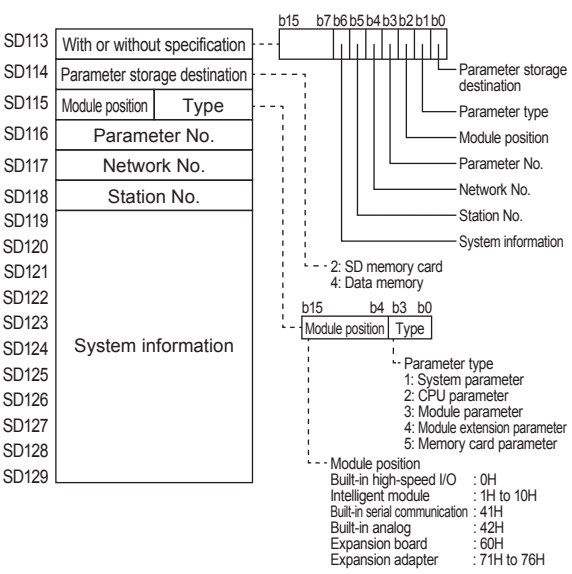
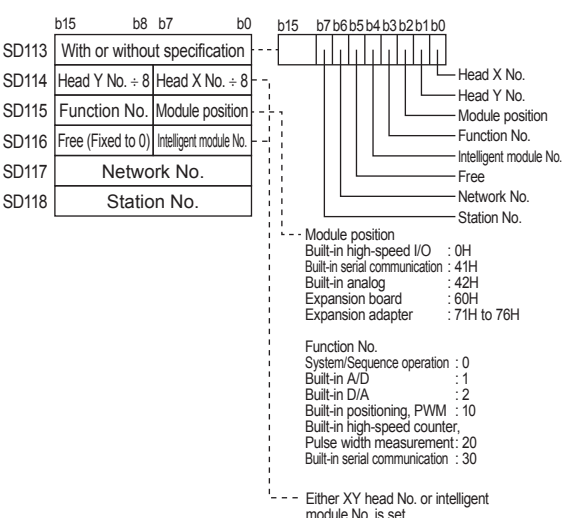
No.	Name	Description	R/W
SD113 to SD143	Detailed information 2	<ul style="list-style-type: none"> Detailed information 2 corresponding to the error code (SD0) is stored. There are four types of information to be stored as shown in the following figures. The type of detailed information 2 can be obtained using SD112 (the value of the "Detailed information 2 information category code" stored in SD112 corresponds to the following figures (2) to (5)). <p>(2) Drive number and file name</p>  <p>(3) Annunciator number</p>  <p>(4) Parameter information</p>  <p>(5) System configuration information</p> 	R

System information

The special registers for system information are shown below.

R: Read only, R/W: Read/Write

No.	Name	Description	R/W
SD200	Switch Status	This register stores the CPU switch status. 0: RUN 1: STOP	R
SD201	LED status	This register stores the LED status.	R
SD203	CPU Status	This register stores the CPU Status. b0: RUN b2: STOP b3: PAUSE	R
SD210	Clock Data (Year)	This register stores the clock data (Year).	R
SD211	Clock Data (Month)	This register stores the clock data (Month).	R
SD212	Clock Data (Day)	This register stores the clock data (Day).	R
SD213	Clock Data (Hour)	This register stores the clock data (Hour).	R
SD214	Clock Data (Minute)	This register stores the clock data (Minute).	R
SD215	Clock Data (Second)	This register stores the clock data (Second).	R
SD216	Clock Data (Day Week)	This register stores the clock data (Day of the Week).	R
SD218	Time zone setting value	The time zone setting value specified in the parameter is stored in increments of minutes.	R
SD250	Loaded Max I/O	This register stores high-order 2 digits of the final I/O number of connected modules +1 in 8-bit binary.	R
SD260	X Device Size [Lower]	This register stores the number of X device points used as 32-bit value.	R
SD261	X Device Size [Upper]		
SD262	Y Device Size [Lower]	This register stores the number of Y device points used as 32-bit value.	R
SD263	Y Device Size [Upper]		
SD264	M Device Size [Lower]	This register stores the number of M device points used as 32-bit value.	R
SD265	M Device Size [Upper]		
SD266	B Device Size [Lower]	This register stores the number of B device points used as 32-bit value.	R
SD267	B Device Size [Upper]		
SD268	SB Device Size [Lower]	This register stores the number of SB device points used as 32-bit value.	R
SD269	SB Device Size [Upper]		
SD270	F Device Size [Lower]	This register stores the number of F device points used as 32-bit value.	R
SD271	F Device Size [Upper]		
SD274	L Device Size [Lower]	This register stores the number of L device points used as 32-bit value.	R
SD275	L Device Size [Upper]		
SD280	D Device Size [Lower]	This register stores the number of D device points used as 32-bit value.	R
SD281	D Device Size [Upper]		
SD282	W Device Size [Lower]	This register stores the number of W device points used as 32-bit value.	R
SD283	W Device Size [Upper]		
SD284	SW Device Size [Lower]	This register stores the number of SW device points used as 32-bit value.	R
SD285	SW Device Size [Upper]		
SD288	T Device Size [Lower]	This register stores the number of T device points used as 32-bit value.	R
SD289	T Device Size [Upper]		
SD290	ST Device Size [Lower]	This register stores the number of ST device points used as 32-bit value.	R
SD291	ST Device Size [Upper]		
SD292	C Device Size [Lower]	This register stores the number of C device points used as 32-bit value.	R
SD293	C Device Size [Upper]		
SD298	LC Device Size [Lower]	This register stores the number of LC device points used as 32-bit value.	R
SD299	LC Device Size [Upper]		
SD300	Z Device Size	This register stores the number of Z device points used.	R
SD302	LZ Device Size	This register stores the number of LZ device points used.	R

No.	Name	Description	R/W
SD304	R Device Size [Lower]	This register stores the number of R device points used as 32-bit value.	R
SD305	R Device Size [Upper]		

System clock

The special registers for system clock are shown below.

R: Read only, R/W: Read/Write

No.	Name	Description	R/W
SD412	One second counter	<ul style="list-style-type: none"> This register is incremented by 1 for each second after the CPU module is set to RUN. A counting cycle from 0 to 32767 to -32768 to 0 is repeated. 	R
SD414	2n second clock setting	<ul style="list-style-type: none"> Stores value n of 2n second clock (Default is 30) Setting can be made between 1 and 32767. 	R/W
SD415	2nms second clock setting	<ul style="list-style-type: none"> Stores value n of 2n ms clock (Default is 30) Setting can be made between 1 and 32767. 	R/W
SD420	Scan counter	<ul style="list-style-type: none"> This register is incremented by 1 each scan after the CPU module is set to RUN. (Not incremented for each scan of an initial execution type program.) A counting cycle from 0 to 32767 to -32768 to 0 is repeated. 	R

Scan information

The special registers for scan information are shown below.

R: Read only, R/W: Read/Write

No.	Name	Description	R/W
SD500	Execution program number	Program number of program currently being executed is stored.	R
SD518	Initial scan time (ms)	This register stores the initial scan time (ms).	R
SD519	Initial scan time (μs)	This register stores the initial scan time (μs).	R
SD520	Current scan time (ms)	This register stores the current scan time (ms).	R
SD521	Current scan time (μs)	This register stores the current scan time (μs).	R
SD522	Minimum scan time (ms)	This register stores the minimum scan time (ms).	R
SD523	Minimum scan time(μs)	This register stores the minimum scan time (μs).	R
SD524	Maximum scan time (ms)	This register stores the maximum scan time (ms).	R
SD525	Maximum scan time (μs)	This register stores the maximum scan time (μs).	R
SD526	END processing time (ms)	This register stores the END processing time (ms).	R
SD527	END processing time (μs)	This register stores the END processing time (μs).	R
SD528	Constant scan waiting time (ms)	This register stores the constant scan wait time (ms).	R
SD529	Constant scan waiting time (μs)	This register stores the constant scan wait time (μs).	R
SD530	Scan program execution time (ms)	This register stores the scan program execution time (ms).	R
SD531	Scan program execution time (μs)	This register stores the scan program execution time (μs).	R

Drive information

The special registers for drive information are shown below.

R: Read only, R/W: Read/Write

No.	Name	Description	R/W
SD600	Memory Card Installation	This register stores the enable/disable classification of the inserted SD card.	R
SD604	SD memory card usage status	This register stores the memory card usage condition.	R
SD606	SD memory card capacity	This register stores the drive 2 storage capacity (unit: 1 K byte). (Free space value after formatting is stored.)	R
SD607	SD memory card capacity	This register stores the drive 2 storage capacity (unit: 1 K byte). (Free space value after formatting is stored.)	R
SD608	SD memory card capacity	This register stores the drive 2 storage capacity (unit: 1 K byte). (Free space value after formatting is stored.)	R

No.	Name	Description	R/W
SD609	SD memory card capacity	This register stores the drive 2 storage capacity (unit: 1 K byte). (Free space value after formatting is stored.)	R
SD610	SD memory card free space capacity	This register stores the free space value in drive 2 (unit: 1 K byte).	R
SD611	SD memory card free space capacity	This register stores the free space value in drive 2 (unit: 1 K byte).	R
SD612	SD memory card free space capacity	This register stores the free space value in drive 2 (unit: 1 K byte).	R
SD613	SD memory card free space capacity	This register stores the free space value in drive 2 (unit: 1 K byte).	R
SD634	Index for the number of data memory write operations	Stores an index for the number of write operations to data memory currently. However, the index does not equal the actual number of write operations.	R
SD635			

Instruction related

The special registers related to instruction execution are shown below.

R: Read only, R/W: Read/Write

No.	Name	Description	R/W
SD757	Current interrupt priority	This register stores the interrupt priority of the interrupt program being executed. 1 to 3: The interrupt priority of interrupt program executed. 0: The interrupt is not executed. (default value)	R
SD758	Interrupt disabling for each priority setting value	This register stores the disable interrupt priority according to the disable interrupt instruction (DI), disable interrupt after the setting priority instruction (DI), and enable interrupt instruction (EI). 1: Disable interrupt priority 1 or less. (Disable interrupt of all priority) (default value) 2: Disable interrupt priority 2 or 3. 3: Disable interrupt priority 3. 0: No priority. (Enable interrupt of all priority)	R

Mask pattern of interrupt pointers

The special registers for the mask pattern of interrupt pointers are shown below.

R: Read only, R/W: Read/Write

No.	Name	Description	R/W
SD1400	Mask pattern I	This register stores the IMASK instruction mask pattern I. b15 to b0: I15 to I0	R/W
SD1401	Mask pattern I	This register stores the IMASK instruction mask pattern I. b15 to b0: I31 to I16	R/W

FX dedicated

The special registers dedicated to FX are shown below.

R: Read only, R/W: Read/Write

No.	Name	Description	R/W
SD4110	Error code 1 details	This register stores the self-diagnosis error code details. • Module position [Low order 8 bit] 0H: Built-in high-speed I/O 41H: Built-in serial communication 42H: Built-in analog 60H: Expansion board 71 to 76H: Expansion adapter • Function No. [Higher order 8 bit] 0: System/Sequence operation 1: Built-in A/D 2: Built-in D/A 10: Built-in positioning, PWM 20: Built-in high-speed counter, Pulse width measurement	R
SD4111	Error code 2 details		
SD4112	Error code 3 details		
SD4113	Error code 4 details		
SD4114	Error code 5 details		
SD4115	Error code 6 details		
SD4116	Error code 7 details		
SD4117	Error code 8 details		
SD4118	Error code 9 details		
SD4119	Error code 10 details		
SD4120	Error code 11 details		
SD4121	Error code 12 details		
SD4122	Error code 13 details		
SD4123	Error code 14 details		

No.	Name	Description	R/W
SD4124	Error code 15 details	This register stores the self-diagnosis error code details.	R
SD4125	Error code 16 details	<ul style="list-style-type: none"> • Module position [Low order 8 bit] 0H: Built-in high-speed I/O 41H: Built-in serial communication 42H: Built-in analog 60H: Expansion board 71 to 76H: Expansion adapter • Function No. [Higher order 8 bit] 0: System/Sequence operation 1: Built-in A/D 2: Built-in D/A 10: Built-in positioning, PWM 20: Built-in high-speed counter, Pulse width measurement 	R
SD4150	Module 1 status information	This register stores the module 1 status information.	R
SD4151	Module 1 error information	This register stores the module 1 error information.	R
SD4152	Module 2 status information	This register stores the module 2 status information.	R
SD4153	Module 2 error information	This register stores the module 2 error information.	R
SD4154	Module 3 status information	This register stores the module 3 status information.	R
SD4155	Module 3 error information	This register stores the module 3 error information.	R
SD4156	Module 4 status information	This register stores the module 4 status information.	R
SD4157	Module 4 error information	This register stores the module 4 error information.	R
SD4158	Module 5 status information	This register stores the module 5 status information.	R
SD4159	Module 5 error information	This register stores the module 5 error information.	R
SD4160	Module 6 status information	This register stores the module 6 status information.	R
SD4161	Module 6 error information	This register stores the module 6 error information.	R
SD4162	Module 7 status information	This register stores the module 7 status information.	R
SD4163	Module 7 error information	This register stores the module 7 error information.	R
SD4164	Module 8 status information	This register stores the module 8 status information.	R
SD4165	Module 8 error information	This register stores the module 8 error information.	R
SD4166	Module 9 status information	This register stores the module 9 status information.	R
SD4167	Module 9 error information	This register stores the module 9 error information.	R
SD4168	Module 10 status information	This register stores the module 10 status information.	R
SD4169	Module 10 error information	This register stores the module 10 error information.	R
SD4170	Module 11 status information	This register stores the module 11 status information.	R
SD4171	Module 11 error information	This register stores the module 11 error information.	R
SD4172	Module 12 status information	This register stores the module 12 status information.	R
SD4173	Module 12 error information	This register stores the module 12 error information.	R
SD4174	Module 13 status information	This register stores the module 13 status information.	R
SD4175	Module 13 error information	This register stores the module 13 error information.	R
SD4176	Module 14 status information	This register stores the module 14 status information.	R
SD4177	Module 14 error information	This register stores the module 14 error information.	R
SD4178	Module 15 status information	This register stores the module 15 status information.	R
SD4179	Module 15 error information	This register stores the module 15 error information.	R
SD4180	Module 16 status information	This register stores the module 16 status information.	R
SD4181	Module 16 error information	This register stores the module 16 error information.	R

FX high-speed input and output

The special registers for FX high-speed input and output are shown below.

R: Read only, R/W: Read/Write

No.	Name	Description	R/W
SD4500	High-speed counter current value [Low-order] (CH1)	This register stores the high-speed counter current value (CH1).	R/W
SD4501	High-speed counter current value [High-order] (CH1)		
SD4502	High-speed counter maximum value [Low-order] (CH1)	This register stores the high-speed counter maximum value (CH1).	R/W
SD4503	High-speed counter maximum value [High-order] (CH1)		

No.	Name	Description	R/W
SD4504	High-speed counter minimum value [Low-order] (CH1)	This register stores the high-speed counter minimum value (CH1).	R/W
SD4505	High-speed counter minimum value [High-order] (CH1)		
SD4506	High-speed counter pulse density [Low-order] (CH1)	This register stores the high-speed counter pulse density (CH1).	R/W
SD4507	High-speed counter pulse density [High-order] (CH1)		
SD4508	High-speed counter rotation speed [Low-order] (CH1)	This register stores the high-speed counter rotation speed (CH1).	R/W
SD4509	High-speed counter rotation speed [High-order] (CH1)		
SD4510	High-speed counter preset control switch (CH1)	This register stores the high-speed counter preset control switch (CH1).	R/W
SD4512	High-speed counter preset value [Low-order] (CH1)	This register stores the high-speed counter preset value (CH1).	R/W
SD4513	High-speed counter preset value [High-order] (CH1)		
SD4514	High-speed counter ring length [Low-order] (CH1)	This register stores the high-speed counter ring length (CH1).	R/W
SD4515	High-speed counter ring length [High-order] (CH1)		
SD4516	High-speed counter measurement-unit time [Low-order] (CH1)	This register stores the high-speed counter measurement-unit time (CH1).	R/W
SD4517	High-speed counter measurement-unit time [High-order] (CH1)		
SD4518	High-speed counter number of pulses per rotation [Low-order] (CH1)	This register stores the high-speed counter number of pulses per rotation (CH1).	R/W
SD4519	High-speed counter number of pulses per rotation [High-order] (CH1)		
SD4530	High-speed counter current value [Low-order] (CH2)	This register stores the high-speed counter current value (CH2).	R/W
SD4531	High-speed counter current value [High-order] (CH2)		
SD4532	High-speed counter maximum value [Low-order] (CH2)	This register stores the high-speed counter maximum value (CH2).	R/W
SD4533	High-speed counter maximum value [High-order] (CH2)		
SD4534	High-speed counter minimum value [Low-order] (CH2)	This register stores the high-speed counter minimum value (CH2).	R/W
SD4535	High-speed counter minimum value [High-order] (CH2)		
SD4536	High-speed counter pulse density [Low-order] (CH2)	This register stores the high-speed counter pulse density (CH2).	R/W
SD4537	High-speed counter pulse density [High-order] (CH2)		
SD4538	High-speed counter rotation speed [Low-order] (CH2)	This register stores the high-speed counter rotation speed (CH2).	R/W
SD4539	High-speed counter rotation speed [High-order] (CH2)		
SD4540	High-speed counter preset control switch (CH2)	This register stores the high-speed counter preset control switch (CH2).	R/W
SD4542	High-speed counter preset value [Low-order] (CH2)	This register stores the high-speed counter preset value (CH2).	R/W
SD4543	High-speed counter preset value [High-order] (CH2)		
SD4544	High-speed counter ring length [Low-order] (CH2)	This register stores the high-speed counter ring length (CH2).	R/W
SD4545	High-speed counter ring length [High-order] (CH2)		
SD4546	High-speed counter measurement-unit time [Low-order] (CH2)	This register stores the high-speed counter measurement-unit time (CH2).	R/W
SD4547	High-speed counter measurement-unit time [High-order] (CH2)		
SD4548	High-speed counter number of pulses per rotation [Low-order] (CH2)	This register stores the high-speed counter number of pulses per rotation (CH2).	R/W
SD4549	High-speed counter number of pulses per rotation [High-order] (CH2)		
SD4560	High-speed counter current value [Low-order] (CH3)	This register stores the high-speed counter current value (CH3).	R/W
SD4561	High-speed counter current value [High-order] (CH3)		
SD4562	High-speed counter maximum value [Low-order] (CH3)	This register stores the high-speed counter maximum value (CH3).	R/W
SD4563	High-speed counter maximum value [High-order] (CH3)		
SD4564	High-speed counter minimum value [Low-order] (CH3)	This register stores the high-speed counter minimum value (CH3).	R/W
SD4565	High-speed counter minimum value [High-order] (CH3)		
SD4566	High-speed counter pulse density [Low-order] (CH3)	This register stores the high-speed counter pulse density (CH3).	R/W
SD4567	High-speed counter pulse density [High-order] (CH3)		
SD4568	High-speed counter rotation speed [Low-order] (CH3)	This register stores the high-speed counter rotation speed (CH3).	R/W
SD4569	High-speed counter rotation speed [High-order] (CH3)		
SD4570	High-speed counter preset control switch (CH3)	This register stores the high-speed counter preset control switch (CH3).	R/W

No.	Name	Description	R/W
SD4572	High-speed counter preset value [Low-order] (CH3)	This register stores the high-speed counter preset value (CH3).	R/W
SD4573	High-speed counter preset value [High-order] (CH3)		
SD4574	High-speed counter ring length [Low-order] (CH3)	This register stores the high-speed counter ring length (CH3).	R/W
SD4575	High-speed counter ring length [High-order] (CH3)		
SD4576	High-speed counter measurement-unit time [Low-order] (CH3)	This register stores the high-speed counter measurement-unit time (CH3).	R/W
SD4577	High-speed counter measurement-unit time [High-order] (CH3)		
SD4578	High-speed counter number of pulses per rotation [Low-order] (CH3)	This register stores the high-speed counter number of pulses per rotation (CH3).	R/W
SD4579	High-speed counter number of pulses per rotation [High-order] (CH3)		
SD4590	High-speed counter current value [Low-order] (CH4)	This register stores the high-speed counter current value (CH4).	R/W
SD4591	High-speed counter current value [High-order] (CH4)		
SD4592	High-speed counter maximum value [Low-order] (CH4)	This register stores the high-speed counter maximum value (CH4).	R/W
SD4593	High-speed counter maximum value [High-order] (CH4)		
SD4594	High-speed counter minimum value [Low-order] (CH4)	This register stores the high-speed counter minimum value (CH4).	R/W
SD4595	High-speed counter minimum value [High-order] (CH4)		
SD4596	High-speed counter pulse density [Low-order] (CH4)	This register stores the high-speed counter pulse density (CH4).	R/W
SD4597	High-speed counter pulse density [High-order] (CH4)		
SD4598	High-speed counter rotation speed [Low-order] (CH4)	This register stores the high-speed counter rotation speed (CH4).	R/W
SD4599	High-speed counter rotation speed [High-order] (CH4)		
SD4600	High-speed counter preset control switch (CH4)	This register stores the high-speed counter preset control switch (CH4).	R/W
SD4602	High-speed counter preset value [Low-order] (CH4)		
SD4603	High-speed counter preset value [High-order] (CH4)	This register stores the high-speed counter preset value (CH4).	R/W
SD4604	High-speed counter ring length [Low-order] (CH4)		
SD4605	High-speed counter ring length [High-order] (CH4)	This register stores the high-speed counter ring length (CH4).	R/W
SD4606	High-speed counter measurement-unit time [Low-order] (CH4)		
SD4607	High-speed counter measurement-unit time [High-order] (CH4)	This register stores the high-speed counter measurement-unit time (CH4).	R/W
SD4608	High-speed counter number of pulses per rotation [Low-order] (CH4)		
SD4609	High-speed counter number of pulses per rotation [High-order] (CH4)	This register stores the high-speed counter number of pulses per rotation (CH4).	R/W
SD4620	High-speed counter current value [Low-order] (CH5)		
SD4621	High-speed counter current value [High-order] (CH5)	This register stores the high-speed counter current value (CH5).	R/W
SD4622	High-speed counter maximum value [Low-order] (CH5)		
SD4623	High-speed counter maximum value [High-order] (CH5)	This register stores the high-speed counter maximum value (CH5).	R/W
SD4624	High-speed counter minimum value [Low-order] (CH5)		
SD4625	High-speed counter minimum value [High-order] (CH5)	This register stores the high-speed counter minimum value (CH5).	R/W
SD4626	High-speed counter pulse density [Low-order] (CH5)		
SD4627	High-speed counter pulse density [High-order] (CH5)	This register stores the high-speed counter pulse density (CH5).	R/W
SD4628	High-speed counter rotation speed [Low-order] (CH5)		
SD4629	High-speed counter rotation speed [High-order] (CH5)	This register stores the high-speed counter rotation speed (CH5).	R/W
SD4630	High-speed counter preset control switch (CH5)		
SD4632	High-speed counter preset value [Low-order] (CH5)	This register stores the high-speed counter preset value (CH5).	R/W
SD4633	High-speed counter preset value [High-order] (CH5)		
SD4634	High-speed counter ring length [Low-order] (CH5)	This register stores the high-speed counter ring length (CH5).	R/W
SD4635	High-speed counter ring length [High-order] (CH5)		
SD4636	High-speed counter measurement-unit time [Low-order] (CH5)	This register stores the high-speed counter measurement-unit time (CH5).	R/W
SD4637	High-speed counter measurement-unit time [High-order] (CH5)		

No.	Name	Description	R/W
SD4638	High-speed counter number of pulses per rotation [Low-order] (CH5)	This register stores the high-speed counter number of pulses per rotation (CH5).	R/W
SD4639	High-speed counter number of pulses per rotation [High-order] (CH5)		
SD4650	High-speed counter current value [Low-order] (CH6)	This register stores the high-speed counter current value (CH6).	R/W
SD4651	High-speed counter current value [High-order] (CH6)		
SD4652	High-speed counter maximum value [Low-order] (CH6)	This register stores the high-speed counter maximum value (CH6).	R/W
SD4653	High-speed counter maximum value [High-order] (CH6)		
SD4654	High-speed counter minimum value [Low-order] (CH6)	This register stores the high-speed counter minimum value (CH6).	R/W
SD4655	High-speed counter minimum value [High-order] (CH6)		
SD4656	High-speed counter pulse density [Low-order] (CH6)	This register stores the high-speed counter pulse density (CH6).	R/W
SD4657	High-speed counter pulse density [High-order] (CH6)		
SD4658	High-speed counter rotation speed [Low-order] (CH6)	This register stores the high-speed counter rotation speed (CH6).	R/W
SD4659	High-speed counter rotation speed [High-order] (CH6)		
SD4660	High-speed counter preset control switch (CH6)	This register stores the high-speed counter preset control switch (CH6).	R/W
SD4662	High-speed counter preset value [Low-order] (CH6)		
SD4663	High-speed counter preset value [High-order] (CH6)	This register stores the high-speed counter preset value (CH6).	R/W
SD4664	High-speed counter ring length [Low-order] (CH6)		
SD4665	High-speed counter ring length [High-order] (CH6)	This register stores the high-speed counter ring length (CH6).	R/W
SD4666	High-speed counter measurement-unit time [Low-order] (CH6)		
SD4667	High-speed counter measurement-unit time [High-order] (CH6)	This register stores the high-speed counter measurement-unit time (CH6).	R/W
SD4668	High-speed counter number of pulses per rotation [Low-order] (CH6)		
SD4669	High-speed counter number of pulses per rotation [High-order] (CH6)	This register stores the high-speed counter number of pulses per rotation (CH6).	R/W
SD4680	High-speed counter current value [Low-order] (CH7)		
SD4681	High-speed counter current value [High-order] (CH7)	This register stores the high-speed counter current value (CH7).	R/W
SD4682	High-speed counter maximum value [Low-order] (CH7)		
SD4683	High-speed counter maximum value [High-order] (CH7)	This register stores the high-speed counter maximum value (CH7).	R/W
SD4684	High-speed counter minimum value [Low-order] (CH7)		
SD4685	High-speed counter minimum value [High-order] (CH7)	This register stores the high-speed counter minimum value (CH7).	R/W
SD4686	High-speed counter pulse density [Low-order] (CH7)		
SD4687	High-speed counter pulse density [High-order] (CH7)	This register stores the high-speed counter pulse density (CH7).	R/W
SD4688	High-speed counter rotation speed [Low-order] (CH7)		
SD4689	High-speed counter rotation speed [High-order] (CH7)	This register stores the high-speed counter rotation speed (CH7).	R/W
SD4690	High-speed counter preset control switch (CH7)		
SD4692	High-speed counter preset value [Low-order] (CH7)	This register stores the high-speed counter preset value (CH7).	R/W
SD4693	High-speed counter preset value [High-order] (CH7)		
SD4694	High-speed counter ring length [Low-order] (CH7)	This register stores the high-speed counter ring length (CH7).	R/W
SD4695	High-speed counter ring length [High-order] (CH7)		
SD4696	High-speed counter measurement-unit time [Low-order] (CH7)	This register stores the high-speed counter measurement-unit time (CH7).	R/W
SD4697	High-speed counter measurement-unit time [High-order] (CH7)		
SD4698	High-speed counter number of pulses per rotation [Low-order] (CH7)	This register stores the high-speed counter number of pulses per rotation (CH7).	R/W
SD4699	High-speed counter number of pulses per rotation [High-order] (CH7)		
SD4710	High-speed counter current value [Low-order] (CH8)	This register stores the high-speed counter current value (CH8).	R/W
SD4711	High-speed counter current value [High-order] (CH8)		
SD4712	High-speed counter maximum value [Low-order] (CH8)	This register stores the high-speed counter maximum value (CH8).	R/W
SD4713	High-speed counter maximum value [High-order] (CH8)		

No.	Name	Description	R/W
SD4714	High-speed counter minimum value [Low-order] (CH8)	This register stores the high-speed counter minimum value (CH8).	R/W
SD4715	High-speed counter minimum value [High-order] (CH8)		
SD4716	High-speed counter pulse density [Low-order] (CH8)	This register stores the high-speed counter pulse density (CH8).	R/W
SD4717	High-speed counter pulse density [High-order] (CH8)		
SD4718	High-speed counter rotation speed [Low-order] (CH8)	This register stores the high-speed counter rotation speed (CH8).	R/W
SD4719	High-speed counter rotation speed [High-order] (CH8)		
SD4720	High-speed counter preset control switch (CH8)	This register stores the high-speed counter preset control switch (CH8).	R/W
SD4722	High-speed counter preset value [Low-order] (CH8)	This register stores the high-speed counter preset value (CH8).	R/W
SD4723	High-speed counter preset value [High-order] (CH8)		
SD4724	High-speed counter ring length [Low-order] (CH8)	This register stores the high-speed counter ring length (CH8).	R/W
SD4725	High-speed counter ring length [High-order] (CH8)		
SD4726	High-speed counter measurement-unit time [Low-order] (CH8)	This register stores the high-speed counter measurement-unit time (CH8).	R/W
SD4727	High-speed counter measurement-unit time [High-order] (CH8)		
SD4728	High-speed counter number of pulses per rotation [Low-order] (CH8)	This register stores the high-speed counter number of pulses per rotation (CH8).	R/W
SD4729	High-speed counter number of pulses per rotation [High-order] (CH8)		
SD4982	High-speed comparison table (high-speed compare instruction) error code	This register stores the high-speed comparison table (high-speed compare instruction) error code.	R/W
SD5000	Multi-point output high-speed comparison table comparison number	This register stores the multi-point output high-speed comparison table comparison number.	R
SD5020	Pulse width measurement rising ring counter value [Low-order] (CH1)	This register stores the pulse width measurement rising ring counter value (CH1).	R/W
SD5021	Pulse width measurement rising ring counter value [High-order] (CH1)		
SD5022	Pulse width measurement falling ring counter value [Low-order] (CH1)	This register stores the pulse width measurement falling ring counter value (CH1).	R/W
SD5023	Pulse width measurement falling ring counter value [High-order] (CH1)		
SD5024	Pulse width measurement latest value [Low-order] (CH1)	This register stores the pulse width measurement latest value (CH1).	R/W
SD5025	Pulse width measurement latest value [High-order] (CH1)		
SD5026	Pulse width measurement maximum value [Low-order] (CH1)	This register stores the pulse width measurement maximum value (CH1).	R/W
SD5027	Pulse width measurement maximum value [High-order] (CH1)		
SD5028	Pulse width measurement minimum value [Low-order] (CH1)	This register stores the pulse width measurement minimum value (CH1).	R/W
SD5029	Pulse width measurement minimum value [High-order] (CH1)		
SD5030	Pulse width measurement cycle latest value [Low-order] (CH1)	This register stores the pulse width measurement cycle latest value (CH1).	R/W
SD5031	Pulse width measurement cycle latest value [High-order] (CH1)		
SD5032	Pulse width measurement cycle maximum value [Low-order] (CH1)	This register stores the pulse width measurement cycle maximum value (CH1).	R/W
SD5033	Pulse width measurement cycle maximum value [High-order] (CH1)		
SD5034	Pulse width measurement cycle minimum value [Low-order] (CH1)	This register stores the pulse width measurement cycle minimum value (CH1).	R/W
SD5035	Pulse width measurement cycle minimum value [High-order] (CH1)		
SD5040	Pulse width measurement rising ring counter value [Low-order] (CH2)	This register stores the pulse width measurement rising ring counter value (CH2).	R/W
SD5041	Pulse width measurement rising ring counter value [High-order] (CH2)		

No.	Name	Description	R/W
SD5042	Pulse width measurement falling ring counter value [Low-order] (CH2)	This register stores the pulse width measurement falling ring counter value (CH2).	R/W
SD5043	Pulse width measurement falling ring counter value [High-order] (CH2)		
SD5044	Pulse width measurement latest value [Low-order] (CH2)	This register stores the pulse width measurement latest value (CH2).	R/W
SD5045	Pulse width measurement latest value [High-order] (CH2)		
SD5046	Pulse width measurement maximum value [Low-order] (CH2)	This register stores the pulse width measurement maximum value (CH2).	R/W
SD5047	Pulse width measurement maximum value [High-order] (CH2)		
SD5048	Pulse width measurement minimum value [Low-order] (CH2)	This register stores the pulse width measurement minimum value (CH2).	R/W
SD5049	Pulse width measurement minimum value [High-order] (CH2)		
SD5050	Pulse width measurement cycle latest value [Low-order] (CH2)	This register stores the pulse width measurement cycle latest value (CH2).	R/W
SD5051	Pulse width measurement cycle latest value [High-order] (CH2)		
SD5052	Pulse width measurement cycle maximum value [Low-order] (CH2)	This register stores the pulse width measurement cycle maximum value (CH2).	R/W
SD5053	Pulse width measurement cycle maximum value [High-order] (CH2)		
SD5054	Pulse width measurement cycle minimum value [Low-order] (CH2)	This register stores the pulse width measurement cycle minimum value (CH2).	R/W
SD5055	Pulse width measurement cycle minimum value [High-order] (CH2)		
SD5060	Pulse width measurement rising ring counter value [Low-order] (CH3)	This register stores the pulse width measurement rising ring counter value (CH3).	R/W
SD5061	Pulse width measurement rising ring counter value [High-order] (CH3)		
SD5062	Pulse width measurement falling ring counter value [Low-order] (CH3)	This register stores the pulse width measurement falling ring counter value (CH3).	R/W
SD5063	Pulse width measurement falling ring counter value [High-order] (CH3)		
SD5064	Pulse width measurement latest value [Low-order] (CH3)	This register stores the pulse width measurement latest value (CH3).	R/W
SD5065	Pulse width measurement latest value [High-order] (CH3)		
SD5066	Pulse width measurement maximum value [Low-order] (CH3)	This register stores the pulse width measurement maximum value (CH3).	R/W
SD5067	Pulse width measurement maximum value [High-order] (CH3)		
SD5068	Pulse width measurement minimum value [Low-order] (CH3)	This register stores the pulse width measurement minimum value (CH3).	R/W
SD5069	Pulse width measurement minimum value [High-order] (CH3)		
SD5070	Pulse width measurement cycle latest value [Low-order] (CH3)	This register stores the pulse width measurement cycle latest value (CH3).	R/W
SD5071	Pulse width measurement cycle latest value [High-order] (CH3)		
SD5072	Pulse width measurement cycle maximum value [Low-order] (CH3)	This register stores the pulse width measurement cycle maximum value (CH3).	R/W
SD5073	Pulse width measurement cycle maximum value [High-order] (CH3)		
SD5074	Pulse width measurement cycle minimum value [Low-order] (CH3)	This register stores the pulse width measurement cycle minimum value (CH3).	R/W
SD5075	Pulse width measurement cycle minimum value [High-order] (CH3)		
SD5080	Pulse width measurement rising ring counter value [Low-order] (CH4)	This register stores the pulse width measurement rising ring counter value (CH4).	R/W
SD5081	Pulse width measurement rising ring counter value [High-order] (CH4)		

No.	Name	Description	R/W
SD5082	Pulse width measurement falling ring counter value [Low-order] (CH4)	This register stores the pulse width measurement falling ring counter value (CH4).	R/W
SD5083	Pulse width measurement falling ring counter value [High-order] (CH4)		
SD5084	Pulse width measurement latest value [Low-order] (CH4)	This register stores the pulse width measurement latest value (CH4).	R/W
SD5085	Pulse width measurement latest value [High-order] (CH4)		
SD5086	Pulse width measurement maximum value [Low-order] (CH4)	This register stores the pulse width measurement maximum value (CH4).	R/W
SD5087	Pulse width measurement maximum value [High-order] (CH4)		
SD5088	Pulse width measurement minimum value [Low-order] (CH4)	This register stores the pulse width measurement minimum value (CH4).	R/W
SD5089	Pulse width measurement minimum value [High-order] (CH4)		
SD5090	Pulse width measurement cycle latest value [Low-order] (CH4)	This register stores the pulse width measurement cycle latest value (CH4).	R/W
SD5091	Pulse width measurement cycle latest value [High-order] (CH4)		
SD5092	Pulse width measurement cycle maximum value [Low-order] (CH4)	This register stores the pulse width measurement cycle maximum value (CH4).	R/W
SD5093	Pulse width measurement cycle maximum value [High-order] (CH4)		
SD5094	Pulse width measurement cycle minimum value [Low-order] (CH4)	This register stores the pulse width measurement cycle minimum value (CH4).	R/W
SD5095	Pulse width measurement cycle minimum value [High-order] (CH4)		
SD5300	PWM pulse output number [Low-order] (CH1)	This register stores the PWM pulse output number (CH1).	R/W
SD5301	PWM pulse output number [High-order] (CH1)		
SD5302	PWM pulse width [Low-order] (CH1)	This register stores the PWM pulse width (CH1).	R/W
SD5303	PWM pulse width [High-order] (CH1)		
SD5304	PWM cycle [Low-order] (CH1)	This register stores the PWM cycle (CH1).	R/W
SD5305	PWM cycle [High-order] (CH1)		
SD5306	PWM Number of output pulses current value monitor [Low-order] (CH1)	This register stores the PWM pulse output number current value (CH1).	R
SD5307	PWM Number of output pulses current value monitor [High-order] (CH1)		
SD5316	PWM pulse output number [Low-order] (CH2)	This register stores the PWM pulse output number (CH2).	R/W
SD5317	PWM pulse output number [High-order] (CH2)		
SD5318	PWM pulse width [Low-order] (CH2)	This register stores the PWM pulse width (CH2).	R/W
SD5319	PWM pulse width [High-order] (CH2)		
SD5320	PWM cycle [Low-order] (CH2)	This register stores the PWM cycle (CH2).	R/W
SD5321	PWM cycle [High-order] (CH2)		
SD5322	PWM Number of output pulses current value monitor [Low-order] (CH2)	This register stores the PWM pulse output number current value (CH2).	R
SD5323	PWM Number of output pulses current value monitor [High-order] (CH2)		
SD5332	PWM pulse output number [Low-order] (CH3)	This register stores the PWM pulse output number (CH3).	R/W
SD5333	PWM pulse output number [High-order] (CH3)		
SD5334	PWM pulse width [Low-order] (CH3)	This register stores the PWM pulse width (CH3).	R/W
SD5335	PWM pulse width [High-order] (CH3)		
SD5336	PWM cycle [Low-order] (CH3)	This register stores the PWM cycle (CH3).	R/W
SD5337	PWM cycle [High-order] (CH3)		
SD5338	PWM Number of output pulses current value monitor [Low-order] (CH3)	This register stores the PWM pulse output number current value (CH3).	R
SD5339	PWM Number of output pulses current value monitor [High-order] (CH3)		

No.	Name	Description	R/W
SD5348	PWM pulse output number [Low-order] (CH4)	This register stores the PWM pulse output number (CH4).	R/W
SD5349	PWM pulse output number [High-order] (CH4)		
SD5350	PWM pulse width [Low-order] (CH4)	This register stores the PWM pulse width (CH4).	R/W
SD5351	PWM pulse width [High-order] (CH4)		
SD5352	PWM cycle [Low-order] (CH4)	This register stores the PWM cycle (CH4).	R/W
SD5353	PWM cycle [High-order] (CH4)		
SD5354	PWM Number of output pulses current value monitor [Low-order] (CH4)	This register stores the PWM pulse output number current value (CH4).	R
SD5355	PWM Number of output pulses current value monitor [High-order] (CH4)		
SD5500	Built-in positioning current address (user unit) [Low-order] (axis 1)	This register stores the current address (user unit) of built-in positioning (axis 1).	R/W
SD5501	Built-in positioning current address (user unit) [High-order] (axis 1)		
SD5502	Built-in positioning current address (pulse unit) [Low-order] (axis 1)	This register stores the current address (pulse unit) of built-in positioning (axis 1).	R/W
SD5503	Built-in positioning current address (pulse unit) [High-order] (axis 1)		
SD5504	Built-in positioning current speed (user unit) [Low-order] (axis 1)	This register stores the current speed of built-in positioning (axis 1).	R
SD5505	Built-in positioning current speed (user unit) [High-order] (axis 1)		
SD5506	Built-in positioning execution table number (axis 1)	This register stores the execution table number of built-in positioning (axis 1).	R
SD5510	Built-in positioning error code (axis 1)	This register stores the error code of built-in positioning (axis 1).	R/W
SD5511	Built-in positioning error table number (axis 1)	This register stores the error table number of built-in positioning (axis 1).	R/W
SD5516	Built-in positioning maximum speed [Low-order] (axis 1)	This register stores the maximum speed of built-in positioning (axis 1).	R/W
SD5517	Built-in positioning maximum speed [High-order] (axis 1)		
SD5518	Built-in positioning bias speed [Low-order] (axis 1)	This register stores the bias speed of built-in positioning (axis 1).	R/W
SD5519	Built-in positioning bias speed [High-order] (axis 1)		
SD5520	Built-in positioning acceleration time (axis 1)	This register stores the acceleration time of built-in positioning (axis 1).	R/W
SD5521	Built-in positioning deceleration time (axis 1)	This register stores the deceleration time of built-in positioning (axis 1).	R/W
SD5526	Built-in positioning zero-return speed [Low-order] (axis 1)	This register stores the zero-return speed of built-in positioning (axis 1).	R/W
SD5527	Built-in positioning zero-return speed [High-order] (axis 1)		
SD5528	Built-in positioning creep speed [Low-order] (axis 1)	This register stores the creep speed of built-in positioning (axis 1).	R/W
SD5529	Built-in positioning creep speed [High-order] (axis 1)		
SD5530	Built-in positioning zero-point address [Low-order] (axis 1)	This register stores the zero-point address of built-in positioning (axis 1).	R/W
SD5531	Built-in positioning zero-point address [High-order] (axis 1)		
SD5532	Built-in positioning number of zero-point signal for zero return	This register stores the number of zero-point signal for zero return of built-in positioning (axis 1).	R/W
SD5533	Built-in positioning zero-return dwell time (axis 1)	This register stores the zero-return dwell time of built-in positioning (axis 1).	R/W
SD5540	Built-in positioning current address (user unit) [Low-order] (axis 2)	This register stores the current address (user unit) of built-in positioning (axis 2).	R/W
SD5541	Built-in positioning current address (user unit) [High-order] (axis 2)		
SD5542	Built-in positioning current address (pulse unit) [Low-order] (axis 2)	This register stores the current address (pulse unit) of built-in positioning (axis 2).	R/W
SD5543	Built-in positioning current address (pulse unit) [High-order] (axis 2)		
SD5544	Built-in positioning current speed (user unit) [Low-order] (axis 2)	This register stores the current speed of built-in positioning (axis 2).	R
SD5545	Built-in positioning current speed (user unit) [High-order] (axis 2)		

No.	Name	Description	R/W
SD5546	Built-in positioning execution table number (axis 2)	This register stores the execution table number of built-in positioning (axis 2).	R
SD5550	Built-in positioning error code (axis 2)	This register stores the error code of built-in positioning (axis 2).	R/W
SD5551	Built-in positioning error table number (axis 2)	This register stores the error table number of built-in positioning (axis 2).	R/W
SD5556	Built-in positioning maximum speed [Low-order] (axis 2)	This register stores the maximum speed of built-in positioning (axis 2).	R/W
SD5557	Built-in positioning maximum speed [High-order] (axis 2)		
SD5558	Built-in positioning bias speed [Low-order] (axis 2)	This register stores the bias speed of built-in positioning (axis 2).	R/W
SD5559	Built-in positioning bias speed [High-order] (axis 2)		
SD5560	Built-in positioning acceleration time (axis 2)	This register stores the acceleration time of built-in positioning (axis 2).	R/W
SD5561	Built-in positioning deceleration time (axis 2)	This register stores the deceleration time of built-in positioning (axis 2).	R/W
SD5566	Built-in positioning zero-return speed [Low-order] (axis 2)	This register stores the zero-return speed of built-in positioning (axis 2).	R/W
SD5567	Built-in positioning zero-return speed [High-order] (axis 2)		
SD5568	Built-in positioning creep speed [Low-order] (axis 2)	This register stores the creep speed of built-in positioning (axis 2).	R/W
SD5569	Built-in positioning creep speed [High-order] (axis 2)		
SD5570	Built-in positioning zero-point address [Low-order] (axis 2)	This register stores the zero-point address of built-in positioning (axis 2).	R/W
SD5571	Built-in positioning zero-point address [High-order] (axis 2)		
SD5572	Built-in positioning number of zero-point signal for zero return (axis 2)	This register stores the number of zero-point signal for zero return of built-in positioning (axis 2).	R/W
SD5573	Built-in positioning zero-return dwell time (axis 2)	This register stores the zero-return dwell time of built-in positioning (axis 2).	R/W
SD5580	Built-in positioning current address (user unit) [Low-order] (axis 3)	This register stores the current address (user unit) of built-in positioning (axis 3).	R/W
SD5581	Built-in positioning current address (user unit) [High-order] (axis 3)		
SD5582	Built-in positioning current address (pulse unit) [Low-order] (axis 3)	This register stores the current address (pulse unit) of built-in positioning (axis 3).	R/W
SD5583	Built-in positioning current address (pulse unit) [High-order] (axis 3)		
SD5584	Built-in positioning current speed (user unit) [Low-order] (axis 3)	This register stores the current speed of built-in positioning (axis 3).	R
SD5585	Built-in positioning current speed (user unit) [High-order] (axis 3)		
SD5586	Built-in positioning execution table number (axis 3)	This register stores the execution table number of built-in positioning (axis 3).	R
SD5590	Built-in positioning error code (axis 3)	This register stores the error code of built-in positioning (axis 3).	R/W
SD5591	Built-in positioning error table number (axis 3)	This register stores the error table number of built-in positioning (axis 3).	R/W
SD5596	Built-in positioning maximum speed [Low-order] (axis 3)	This register stores the maximum speed of built-in positioning (axis 3).	R/W
SD5597	Built-in positioning maximum speed [High-order] (axis 3)		
SD5598	Built-in positioning bias speed [Low-order] (axis 3)	This register stores the bias speed of built-in positioning (axis 3).	R/W
SD5599	Built-in positioning bias speed [High-order] (axis 3)		
SD5600	Built-in positioning acceleration time (axis 3)	This register stores the acceleration time of built-in positioning (axis 3).	R/W
SD5601	Built-in positioning deceleration time (axis 3)	This register stores the deceleration time of built-in positioning (axis 3).	R/W
SD5606	Built-in positioning zero-return speed [Low-order] (axis 3)	This register stores the zero-return speed of built-in positioning (axis 3).	R/W
SD5607	Built-in positioning zero-return speed [High-order] (axis 3)		
SD5608	Built-in positioning creep speed [Low-order] (axis 3)	This register stores the creep speed of built-in positioning (axis 3).	R/W
SD5609	Built-in positioning creep speed [High-order] (axis 3)		
SD5610	Built-in positioning zero-point address [Low-order] (axis 3)	This register stores the zero-point address of built-in positioning (axis 3).	R/W
SD5611	Built-in positioning zero-point address [High-order] (axis 3)		
SD5612	Built-in positioning number of zero-point signal for zero return (axis 3)	This register stores the number of zero-point signal for zero return of built-in positioning (axis 3).	R/W

No.	Name	Description	R/W
SD5613	Built-in positioning zero-return dwell time (axis 3)	This register stores the zero-return dwell time of built-in positioning (axis 3).	R/W
SD5620	Built-in positioning current address (user unit) [Low-order] (axis 4)	This register stores the current address (user unit) of built-in positioning (axis 4).	R/W
SD5621	Built-in positioning current address (user unit) [High-order] (axis 4)		
SD5622	Built-in positioning current address (pulse unit) [Low-order] (axis 4)	This register stores the current address (pulse unit) of built-in positioning (axis 4).	R/W
SD5623	Built-in positioning current address (pulse unit) [High-order] (axis 4)		
SD5624	Built-in positioning current speed (user unit) [Low-order] (axis 4)	This register stores the current speed of built-in positioning (axis 4).	R
SD5625	Built-in positioning current speed (user unit) [High-order] (axis 4)		
SD5626	Built-in positioning execution table number (axis 4)	This register stores the execution table number of built-in positioning (axis 4).	R
SD5630	Built-in positioning error code (axis 4)	This register stores the error code of built-in positioning (axis 4).	R/W
SD5631	Built-in positioning error table number (axis 4)	This register stores the error table number of built-in positioning (axis 4).	R/W
SD5636	Built-in positioning maximum speed [Low-order] (axis 4)	This register stores the maximum speed of built-in positioning (axis 4).	R/W
SD5637	Built-in positioning maximum speed [High-order] (axis 4)		
SD5638	Built-in positioning bias speed [Low-order] (axis 4)	This register stores the bias speed of built-in positioning (axis 4).	R/W
SD5639	Built-in positioning bias speed [High-order] (axis 4)		
SD5640	Built-in positioning acceleration time (axis 4)	This register stores the acceleration time of built-in positioning (axis 4).	R/W
SD5641	Built-in positioning deceleration time (axis 4)	This register stores the deceleration time of built-in positioning (axis 4).	R/W
SD5646	Built-in positioning zero-return speed [Low-order] (axis 4)	This register stores the zero-return speed of built-in positioning (axis 4).	R/W
SD5647	Built-in positioning zero-return speed [High-order] (axis 4)		
SD5648	Built-in positioning creep speed [Low-order] (axis 4)	This register stores the creep speed of built-in positioning (axis 4).	R/W
SD5649	Built-in positioning creep speed [High-order] (axis 4)		
SD5650	Built-in positioning zero-point address [Low-order] (axis 4)	This register stores the zero-point address of built-in positioning (axis 4).	R/W
SD5651	Built-in positioning zero-point address [High-order] (axis 4)		
SD5652	Built-in positioning number of zero-point signal for zero return (axis 4)	This register stores the number of zero-point signal for zero return of built-in positioning (axis 4).	R/W
SD5653	Built-in positioning zero-return dwell time (axis 4)	This register stores the zero-return dwell time of built-in positioning (axis 4).	R/W

Built-in analog

The special registers for built-in analog are shown below.

R: Read only, R/W: Read/Write

No.	Name	Description	R/W
SD6020	CH1 Digital output value	This register stores the digital output value.	R
SD6021	CH1 Digital operation value	This register stores the digital operation value.	R
SD6022	CH1 Analog input voltage monitor	This register stores the analog input voltage value.	R
SD6023	CH1 Averaging process setting	This register stores the averaging process setting.	R/W
SD6024	CH1 Time Average/Frequency Average/Moving Average	This register stores the time average/frequency average/moving average.	R/W
SD6026	CH1 Maximum value	This register stores the maximum value.	R
SD6027	CH1 Minimum value	This register stores the minimum value.	R
SD6028	CH1 Scaling upper limit value	This register stores the scaling upper limit value.	R/W
SD6029	CH1 Scaling lower limit value	This register stores the scaling lower limit value.	R/W
SD6030	CH1 Shifting amount to conversion value	This register stores the shifting amount of conversion value.	R/W
SD6031	CH1 Process alarm upper upper limit value	This register stores the process alarm upper upper limit value.	R/W
SD6032	CH1 Process alarm upper lower limit value	This register stores the process alarm upper lower limit value.	R/W
SD6033	CH1 Process alarm lower upper limit value	This register stores the process alarm lower upper limit value.	R/W

No.	Name	Description	R/W
SD6034	CH1 Process alarm lower lower limit value	This register stores the process alarm lower lower limit value.	R/W
SD6058	CH1 Latest alarm code	This register stores the latest alarm code.	R
SD6059	CH1 Latest error code	This register stores the latest error code.	R
SD6060	Ch2 Digital output value	This register stores the digital output value.	R
SD6061	CH2 Digital operation value	This register stores the digital operation value.	R
SD6062	CH2 Analog input voltage monitor	This register stores the analog input voltage value.	R
SD6063	CH2 Averaging process setting	This register stores the averaging process setting.	R/W
SD6064	CH2 Time Average/Frequency Average/Moving Average	This register stores the time average/frequency average/moving average.	R/W
SD6066	CH2 Maximum value	This register stores the maximum value.	R
SD6067	CH2 Minimum value	This register stores the minimum value.	R
SD6068	CH2 Scaling upper limit value	This register stores the scaling upper limit value.	R/W
SD6069	CH2 Scaling lower limit value	This register stores the scaling lower limit value.	R/W
SD6070	CH2 Shifting amount to conversion value	This register stores the shifting amount of conversion value.	R/W
SD6071	CH2 Process alarm upper upper limit value	This register stores the process alarm upper upper limit value.	R/W
SD6072	CH2 Process alarm upper lower limit value	This register stores the process alarm upper lower limit value.	R/W
SD6073	CH2 Process alarm lower upper limit value	This register stores the process alarm lower upper limit value.	R/W
SD6074	CH2 Process alarm lower lower limit value	This register stores the process alarm lower lower limit value.	R/W
SD6098	CH2 Latest alarm code	This register stores the latest alarm code.	R
SD6099	CH2 Latest error code	This register stores the latest error code.	R
SD6180	Digital input value	This register stores the digital input value.	R/W
SD6181	Digital operation value	This register stores the digital operation value.	R
SD6182	Analog output voltage monitor	This register stores the analog output voltage value.	R
SD6183	HOLD/CLEAR setting	This register stores the HOLD/CLEAR setting.	R/W
SD6184	HOLD setting value	This register stores the HOLD setting value.	R/W
SD6188	Scaling upper limit value	This register stores the scaling upper limit value.	R/W
SD6189	Scaling lower limit value	This register stores the scaling lower limit value.	R/W
SD6190	Input value shift amount	This register stores the input value shift amount.	R/W
SD6191	Warning output upper limit value	This register stores the warning output upper limit value.	R/W
SD6192	Warning output lower limit value	This register stores the warning output lower limit value.	R/W
SD6218	Latest alarm code	This register stores the latest alarm code.	R
SD6219	Latest error code	This register stores the latest error code.	R

FX Compatible area

The special registers for FX compatible area are shown below.

R: Read only, R/W: Read/Write

No.	Name	Description	R/W
SD8000	Watchdog timer	This register stores the watchdog timer.	R/W
SD8001	PLC type and system version	This register stores the PLC type and system version.	R
SD8005	Battery voltage	This register stores the battery voltage.	R
SD8006	Low battery voltage	This register stores the low battery voltage.	R/W
SD8007	Power failure count	This register stores the power failure count.	R
SD8008	Power failure detection period	This register stores the power failure detection period. When the power supply voltage is 200 V AC, the time can be change to 10 to 100 ms.	R/W
SD8010	Current scan time	This register stores the current scan time.	R
SD8011	Minimum scan time	This register stores the minimum scan time.	R
SD8012	Maximum scan time	This register stores the maximum scan time.	R
SD8013	RTC: Seconds	This register stores the seconds data.	R
SD8014	RTC: Minute data	This register stores the minute data.	R
SD8015	RTC: Hour data	This register stores the hour data.	R
SD8016	RTC: Day data	This register stores the day data.	R
SD8017	RTC: Month data	This register stores the month data.	R

No.	Name	Description	R/W
SD8018	RTC: Year data	This register stores the year data.	R
SD8019	RTC: Day of week data	This register stores the day of week data.	R
SD8039	Constant scan duration	This register stores the constant scan duration.	R/W
SD8040	ON state number 1	This register stores the ON state number 1.	R/W
SD8041	ON state number 2	This register stores the ON state number 2.	R/W
SD8042	ON state number 3	This register stores the ON state number 3.	R/W
SD8043	ON state number 4	This register stores the ON state number 4.	R/W
SD8044	ON state number 5	This register stores the ON state number 5.	R/W
SD8045	ON state number 6	This register stores the ON state number 6.	R/W
SD8046	ON state number 7	This register stores the ON state number 7.	R/W
SD8047	ON state number 8	This register stores the ON state number 8.	R/W
SD8049	Lowest active Annunciator	This register stores the lowest active annunciator.	R/W
SD8063	Serial communication error code (ch1)	This register stores the serial communication error code (ch1).	R
SD8067	Operation error	This register stores the error code number of operation error.	R
SD8099	High speed ring counter	This register stores the high speed ring counter count value. (units: 0.1 ms)	R/W
SD8136	PLSY Output number [Low-order]	This register stores the PLSY instruction output pulse number.	R
SD8137	PLSY Output number [High-order]		
SD8140	PLSY Accumulated number of pulses output [Low-order] (axis 1)	This register stores the PLSY instruction accumulated number of pulses output (to axis 1).	R
SD8141	PLSY Accumulated number of pulses output [High-order] (axis 1)		
SD8142	PLSY Accumulated number of pulses output [Low-order] (axis 2)	This register stores the PLSY instruction accumulated number of pulses output (to axis 2).	R
SD8143	PLSY Accumulated number of pulses output [High-order] (axis 2)		
SD8152	Error No. of Inverter communication (ch1)	This register stores the error code of Inverter communication (ch1).	R
SD8154	Error parameter No. of IVBWR (ch1)	This register stores the error parameter No. of IVBWR instruction (ch1).	R
SD8157	Error No. of Inverter communication (ch2)	This register stores the error code of Inverter communication (ch2).	R
SD8159	Error parameter No. of IVBWR (ch2)	This register stores the error parameter No. of IVBWR instruction (ch2).	R
SD8173	Station number	This register stores the station number.	R
SD8174	Total number of slave stations	This register stores the total number of slave stations.	R
SD8175	Refresh range	This register stores the refresh range.	R
SD8201	Current link scan time	This register stores the current link scan time.	R
SD8202	Maximum link scan time	This register stores the maximum link scan time.	R
SD8203	Number of communication error at master station	This register stores the number of communication error at master station.	R
SD8204	Number of communication error at slave station No.1	This register stores the number of communication error at slave station No.1.	R
SD8205	Number of communication error at slave station No.2	This register stores the number of communication error at slave station No.2.	R
SD8206	Number of communication error at slave station No.3	This register stores the number of communication error at slave station No.3.	R
SD8207	Number of communication error at slave station No.4	This register stores the number of communication error at slave station No.4.	R
SD8208	Number of communication error at slave station No.5	This register stores the number of communication error at slave station No.5.	R
SD8209	Number of communication error at slave station No.6	This register stores the number of communication error at slave station No.6.	R
SD8210	Number of communication error at slave station No.7	This register stores the number of communication error at slave station No.7.	R
SD8211	Code of communication error at master station	This register stores the code of communication error at master station.	R

No.	Name	Description	R/W
SD8212	Code of communication error at slave station No.1	This register stores the code of communication error at slave station No.1.	R
SD8213	Code of communication error at slave station No.2	This register stores the code of communication error at slave station No.2.	R
SD8214	Code of communication error at slave station No.3	This register stores the code of communication error at slave station No.3.	R
SD8215	Code of communication error at slave station No.4	This register stores the code of communication error at slave station No.4.	R
SD8216	Code of communication error at slave station No.5	This register stores the code of communication error at slave station No.5.	R
SD8217	Code of communication error at slave station No.6	This register stores the code of communication error at slave station No.6.	R
SD8218	Code of communication error at slave station No.7	This register stores the code of communication error at slave station No.7.	R
SD8230	Number of communication error at master station	This register stores the number of communication error at master station.	R
SD8231	Number of communication error at slave station No.1	This register stores the number of communication error at slave station No.1.	R
SD8232	Number of communication error at slave station No.2	This register stores the number of communication error at slave station No.2.	R
SD8233	Number of communication error at slave station No.3	This register stores the number of communication error at slave station No.3.	R
SD8234	Number of communication error at slave station No.4	This register stores the number of communication error at slave station No.4.	R
SD8235	Number of communication error at slave station No.5	This register stores the number of communication error at slave station No.5.	R
SD8236	Number of communication error at slave station No.6	This register stores the number of communication error at slave station No.6.	R
SD8237	Number of communication error at slave station No.7	This register stores the number of communication error at slave station No.7.	R
SD8310	RND Random number generation [Low-order]	This register stores the RND random number generation data.	R
SD8311	RND Random number generation [High-order]		
SD8330	Counted number of scans for timing clock output 1	This register stores the scan count for timing clock output 1.	R
SD8331	Counted number of scans for timing clock output 2	This register stores the scan count for timing clock output 2.	R
SD8332	Counted number of scans for timing clock output 3	This register stores the scan count for timing clock output 3.	R
SD8333	Counted number of scans for timing clock output 4	This register stores the scan count for timing clock output 4.	R
SD8334	Counted number of scans for timing clock output 5	This register stores the scan count for timing clock output 5.	R
SD8340	Current address [Low-order] (axis 1: pulse units)	This register stores the current address (axis 1: pulse units).	R
SD8341	Current address [High-order] (axis 1: pulse units)		
SD8350	Current address [Low-order] (axis 2: pulse units)	This register stores the current address (axis 2: pulse units).	R
SD8351	Current address [High-order] (axis 2: pulse units)		
SD8360	Current address [Low-order] (axis 3: pulse units)	This register stores the current address (axis 3: pulse units).	R
SD8361	Current address [High-order] (axis 3: pulse units)		
SD8370	Current address [Low-order] (axis 4: pulse units)	This register stores the current address (axis 4: pulse units).	R
SD8371	Current address [High-order] (axis 4: pulse units)		
SD8398	1 ms ring counter [Low-order]	This register stores the 1 ms ring counter.	R
SD8399	1 ms ring counter [High-order]		
SD8402	RS2 amount of remaining data (ch1)/MODBUS communication error code (ch1)	This register stores the amount of remaining data(ch1)/MODBUS communication error code (ch1).	R
SD8403	RS2 receive data points (ch1)/MODBUS communication error details (ch1)	This register stores the receive data points (ch1)/MODBUS communication error details (ch1).	R
SD8405	RS2 communication parameter display (ch1)/MODBUS communication format display (ch1)	This register stores the communication parameter display (ch1)/MODBUS communication format display (ch1).	R
SD8408	MODBUS communication retry times (ch1)	This register stores the MODBUS communication current retry times (ch1).	R
SD8414	RS2 receive sum (received data) (ch1)	This register stores the ch1 receive sum (received data).	R
SD8415	RS2 receive sum (calculated result) (ch1)	This register stores the ch1 receive sum (calculated result) .	R
SD8416	RS2 send sum (ch1)	This register stores the send sum (ch1).	R

No.	Name	Description	R/W
SD8419	Operation mode (ch1)	This register stores the operation mode (ch1).	R
SD8422	RS2 amount of remaining data (ch2)/MODBUS communication error code (ch2)	This register stores the amount of remaining data (ch2)/MODBUS communication error code (ch2).	R
SD8423	RS2 receive data points (ch2)/MODBUS communication error details (ch2)	This register stores the receive data points (ch2)/MODBUS communication error details (ch2).	R
SD8425	RS2 receive sum (calculated result) (ch2)	This register stores the receive sum (calculated result).	R
SD8428	MODBUS communication retry times (ch2)	This register stores the MODBUS communication current retry times (ch2).	R
SD8434	RS2 receive sum (received data) (ch2)	This register stores the ch2 receive sum (received data).	R
SD8435	RS2 receive sum (calculated result) (ch2)	This register stores the ch2 receive sum (calculated result).	R
SD8436	RS2 send sum (ch2)	This register stores the send sum (ch2).	R
SD8438	Serial communication error code (ch2)	This register stores the serial communication error code (ch2).	R
SD8439	Operation mode (ch2)	This register stores the operation mode (ch2).	R
SD8492	IP address setting [Low-order]	This register stores the IP address.	R/W
SD8493	IP address setting [High-order]		
SD8494	Subnet mask setting [Low-order]	This register stores the subnet mask.	R/W
SD8495	Subnet mask setting [High-order]		
SD8496	Default gateway IP address setting [Low-order]	This register stores the default gateway IP address.	R/W
SD8497	Default gateway IP address setting [High-order]		
SD8498	IP address storage area write error code	This register stores error codes if writing to IP address storage area is failed.	R
SD8499	IP address storage area clear error code	This register stores error codes if clear to IP address storage area is failed.	R

Serial communication

The special registers for serial communication are shown below.

R: Read only, R/W: Read/Write

No.	Name	Description	R/W
SD8500	Serial communication error code (ch1)	This register stores the serial communication error code 1 (ch1).	R
SD8501	Serial communication error details (ch1)	This register stores the serial communication error details 1 (ch1).	R
SD8502	Serial communication setting (ch1)	This register stores the serial communication setting (ch1).	R
SD8503	Serial communication operational mode (ch1)	This register stores the serial communication operational mode 1 (ch1).	R
SD8510	Serial communication error code (ch2)	This register stores the serial communication error code 2 (ch2).	R
SD8511	Serial communication error details (ch2)	This register stores the serial communication error details 2 (ch2).	R
SD8512	Serial communication setting (ch2)	This register stores the serial communication setting (ch2).	R
SD8513	Serial communication operational mode (ch2)	This register stores the serial communication operational mode 2 (ch2).	R
SD8520	Serial communication error code (ch3)	This register stores the serial communication error code 3 (ch3).	R
SD8521	Serial communication error details (ch3)	This register stores the serial communication error details 3 (ch3).	R
SD8522	Serial communication setting (ch3)	This register stores the serial communication setting (ch3).	R
SD8523	Serial communication operational mode (ch3)	This register stores the serial communication operational mode 3 (ch3).	R
SD8530	Serial communication error code (ch4)	This register stores the serial communication error code 4 (ch4).	R
SD8531	Serial communication error details (ch4)	This register stores the serial communication error details 4 (ch4).	R
SD8532	Serial communication setting (ch4)	This register stores the serial communication setting (ch4).	R
SD8533	Serial communication operational mode (ch4)	This register stores the serial communication operational mode 4 (ch4).	R
SD8560	Remaining points of send data (ch1)	This register stores the remaining points of send data (ch1).	R
SD8561	Receive data points monitor (ch1)	This register stores the receive data points monitor (ch1).	R
SD8563	Receive sum (received data) (ch1)	This register stores the receive sum (received data) (ch1).	R
SD8564	Receive sum (received result) (ch1)	This register stores the receive sum (received result) (ch1).	R
SD8565	Send sum (ch1)	This register stores the send sum (ch1).	R
SD8570	Remaining points of send data (ch2)	This register stores the remaining points of send data (ch2).	R
SD8571	Receive data points monitor (ch2)	This register stores the receive data points monitor (ch2).	R

No.	Name	Description	R/W
SD8573	Receive sum (received data) (ch2)	This register stores the receive sum (received data) (ch2).	R
SD8574	Receive sum (received result) (ch2)	This register stores the receive sum (received result) (ch2).	R
SD8575	Send sum (ch2)	This register stores the send sum (ch2).	R
SD8580	Remaining points of send data (ch3)	This register stores the remaining points of send data (ch3).	R
SD8581	Receive data points monitor (ch3)	This register stores the receive data points monitor (ch3).	R
SD8583	Receive sum (received data) (ch3)	This register stores the receive sum (received data) (ch3).	R
SD8584	Receive sum (received result) (ch3)	This register stores the receive sum (received result) (ch3).	R
SD8585	Send sum (ch3)	This register stores the send sum (ch3).	R
SD8590	Remaining points of send data (ch4)	This register stores the remaining points of send data (ch4).	R
SD8591	Receive data points monitor (ch4)	This register stores the receive data points monitor (ch4).	R
SD8593	Receive sum (received data) (ch4)	This register stores the receive sum (received data) (ch4).	R
SD8594	Receive sum (received result) (ch4)	This register stores the receive sum (received result) (ch4).	R
SD8595	Send sum (ch4)	This register stores the send sum (ch4).	R
SD8621	Timeout time (ch1)	This register stores the timeout time (ch1).	R
SD8622	8-bit processing mode (ch1)	This register stores the 8-bit processing mode (ch1).	R
SD8623	Header 1 and 2 (ch1)	This register stores the header 1 and 2 (ch1).	R
SD8624	Header 3 and 4 (ch1)	This register stores the header 3 and 4 (ch1).	R
SD8625	Terminator 1 and 2 (ch1)	This register stores the terminator 1 and 2 (ch1).	R
SD8626	Terminator 3 and 4 (ch1)	This register stores the terminator 3 and 4 (ch1).	R
SD8631	Timeout time (ch2)	This register stores the timeout time (ch2).	R
SD8632	8-bit processing mode (ch2)	This register stores the 8-bit processing mode (ch2).	R
SD8633	Header 1 and 2 (ch2)	This register stores the header 1 and 2 (ch2).	R
SD8634	Header 3 and 4 (ch2)	This register stores the header 3 and 4 (ch2).	R
SD8635	Terminator 1 and 2 (ch2)	This register stores the terminator 1 and 2 (ch2).	R
SD8636	Terminator 3 and 4 (ch2)	This register stores the terminator 3 and 4 (ch2).	R
SD8641	Timeout time (ch3)	This register stores the timeout time (ch3).	R
SD8642	8-bit processing mode (ch3)	This register stores the 8-bit processing mode (ch3).	R
SD8643	Header 1 and 2 (ch3)	This register stores the header 1 and 2 (ch3).	R
SD8644	Header 3 and 4 (ch3)	This register stores the header 3 and 4 (ch3).	R
SD8645	Terminator 1 and 2 (ch3)	This register stores the terminator 1 and 2 (ch3).	R
SD8646	Terminator 3 and 4 (ch3)	This register stores the terminator 3 and 4 (ch3).	R
SD8651	Timeout time (ch4)	This register stores the timeout time (ch4).	R
SD8652	8-bit processing mode (ch4)	This register stores the 8-bit processing mode (ch4).	R
SD8653	Header 1 and 2 (ch4)	This register stores the header 1 and 2 (ch4).	R
SD8654	Header 3 and 4 (ch4)	This register stores the header 3 and 4 (ch4).	R
SD8655	Terminator 1 and 2 (ch4)	This register stores the terminator 1 and 2 (ch4).	R
SD8656	Terminator 3 and 4 (ch4)	This register stores the terminator 3 and 4 (ch4).	R
SD8740	Station number setting (ch1)	This register stores the station number setting (ch1).	R/W
SD8741	Message frame and form (ch1)	This register stores the message frame and form (ch1).	R
SD8742	Timeout time (ch1)	This register stores the timeout time (ch1).	R
SD8750	Station number setting (ch2)	This register stores the station number setting (ch2).	R/W
SD8751	Message frame and form (ch2)	This register stores the message frame and form (ch2).	R
SD8752	Timeout time (ch2)	This register stores the timeout time (ch2).	R
SD8760	Station number setting (ch3)	This register stores the station number setting (ch3).	R/W
SD8761	Message frame and form (ch3)	This register stores the message frame and form (ch3).	R
SD8762	Timeout time (ch3)	This register stores the timeout time (ch3).	R
SD8770	Station number setting (ch4)	This register stores the station number setting (ch4).	R/W
SD8771	Message frame and form (ch4)	This register stores the message frame and form (ch4).	R
SD8772	Timeout time (ch4)	This register stores the timeout time (ch4).	R
SD8800	Current retry value (ch1)	This register stores the current retry value (ch1).	R
SD8810	Current retry value (ch2)	This register stores the current retry value (ch2).	R
SD8820	Current retry value (ch3)	This register stores the current retry value (ch3).	R
SD8830	Current retry value (ch4)	This register stores the current retry value (ch4).	R

No.	Name	Description	R/W
SD8860	Communication format (ch1)	This register stores the communication format (ch1).	R
SD8861	Slave node address (ch1)	This register stores the host station number (ch1).	R
SD8862	Slave response timeout (ch1)	This register stores the slave response timeout (ch1).	R
SD8863	Turn around delay (ch1)	This register stores the broadcast delay (ch1).	R
SD8864	Message to message delay (ch1)	This register stores the request to request delay (ch1).	R
SD8865	Number of retries (ch1)	This register stores the number of retries during timeout (ch1).	R
SD8870	Communication format (ch2)	This register stores the communication format (ch2).	R
SD8871	Slave node address (ch2)	This register stores the host station number (ch2).	R
SD8872	Slave response timeout (ch2)	This register stores the slave response timeout (ch2).	R
SD8873	Turn around delay (ch2)	This register stores the broadcast delay (ch12).	R
SD8874	Message to message delay (ch2)	This register stores the request to request delay (ch2).	R
SD8875	Number of retries (ch2)	This register stores the number of retries during timeout (ch2).	R
SD8880	Communication format (ch3)	This register stores the communication format (ch3).	R
SD8881	Slave node address (ch3)	This register stores the host station number (ch3).	R
SD8882	Slave response timeout (ch3)	This register stores the slave response timeout (ch3).	R
SD8883	Turn around delay (ch3)	This register stores the broadcast delay (ch3).	R
SD8884	Message to message delay (ch3)	This register stores the request to request delay (ch3).	R
SD8885	Number of retries (ch3)	This register stores the number of retries during timeout (ch3).	R
SD8890	Communication format (ch4)	This register stores the communication format (ch4).	R
SD8891	Slave node address (ch4)	This register stores the host station number (ch4).	R
SD8892	Slave response timeout (ch4)	This register stores the slave response timeout (ch4).	R
SD8893	Turn around delay (ch4)	This register stores the broadcast delay (ch4).	R
SD8894	Message to message delay (ch4)	This register stores the request to request delay (ch4).	R
SD8895	Number of retries (ch4)	This register stores the number of retries during timeout (ch4).	R
SD8921	IVBWR instruction error parameter number (ch1)	This register stores the IVBWR instruction error parameter number (ch1).	R
SD8931	IVBWR instruction error parameter number (ch2)	This register stores the IVBWR instruction error parameter number (ch2).	R
SD8941	IVBWR instruction error parameter number (ch3)	This register stores the IVBWR instruction error parameter number (ch3).	R
SD8951	IVBWR instruction error parameter number (ch4)	This register stores the IVBWR instruction error parameter number (ch4).	R
SD8981	Response wait time (ch1)	This register stores the response wait time (ch1).	R
SD8991	Response wait time (ch2)	This register stores the response wait time (ch2).	R
SD9001	Response wait time (ch3)	This register stores the response wait time (ch3).	R
SD9011	Response wait time (ch4)	This register stores the response wait time (ch4).	R
SD9040	Station number	This register stores the station number.	R
SD9041	Total number of slave stations	This register stores the total number of slave stations.	R
SD9043	Current link scan time	This register stores the current link scan time.	R
SD9044	Maximum link scan time	This register stores the maximum link scan time.	R
SD9045	Number of communication error at master station	This register stores the number of communication error at master station.	R
SD9046	Number of communication error at slave station No.1	This register stores the number of communication error at slave station No.1.	R
SD9047	Number of communication error at slave station No.2	This register stores the number of communication error at slave station No.2.	R
SD9048	Number of communication error at slave station No.3	This register stores the number of communication error at slave station No.3.	R
SD9049	Number of communication error at slave station No.4	This register stores the number of communication error at slave station No.4.	R
SD9050	Number of communication error at slave station No.5	This register stores the number of communication error at slave station No.5.	R
SD9051	Number of communication error at slave station No.6	This register stores the number of communication error at slave station No.6.	R
SD9052	Number of communication error at slave station No.7	This register stores the number of communication error at slave station No.7.	R

No.	Name	Description	R/W
SD9061	Code of communication error at master station	This register stores the code of communication error at master station.	R
SD9062	Code of communication error at slave station No.1	This register stores the code of communication error at slave station No.1.	R
SD9063	Code of communication error at slave station No.2	This register stores the code of communication error at slave station No.2.	R
SD9064	Code of communication error at slave station No.3	This register stores the code of communication error at slave station No.3.	R
SD9065	Code of communication error at slave station No.4	This register stores the code of communication error at slave station No.4.	R
SD9066	Code of communication error at slave station No.5	This register stores the code of communication error at slave station No.5.	R
SD9067	Code of communication error at slave station No.6	This register stores the code of communication error at slave station No.6.	R
SD9068	Code of communication error at slave station No.7	This register stores the code of communication error at slave station No.7.	R
SD9080	Station number setting	This register stores the station number setting.	R/W
SD9081	Total slave station number setting	This register stores the total slave station number setting.	R/W
SD9082	Refresh range setting	This register stores the refresh range setting.	R
SD9083	Retry count setting	This register stores the retry count setting.	R
SD9084	Communication time-out setting	This register stores the communication time-out setting.	R

Built-in Ethernet

The special registers for built-in Ethernet are shown below.

R: Read only, R/W: Read/Write

No.	Name	Description	R/W
SD10050	Local node IP address [Low-order]	This register stores the local node IP address.	R
SD10051	Local node IP address [High-order]		
SD10060	Subnet mask [Low-order]	This register stores the subnet mask.	R
SD10061	Subnet mask [High-order]		
SD10064	Default gateway IP address [Low-order]	This register stores the default gateway IP address.	R
SD10065	Default gateway IP address [High-order]		
SD10074	Local node MAC address	This register stores the local node MAC address (5 and 6 bytes).	R
SD10075	Local node MAC address	This register stores the local node MAC address (3 and 4 bytes).	R
SD10076	Local node MAC address	This register stores the local node MAC address (1 and 2 bytes).	R
SD10082	Communication speed setting	This register stores the communication speed setting.	R
SD10084	MELSOFT connection TCP port No.	This register stores the MELSOFT connection TCP port No.	R
SD10086	MELSOFT direct connection port No.	This register stores the MELSOFT direct connection port No.	R
SD10130	Connection No.1 latest error code	This register stores the connection No.1 latest error code.	R
SD10131	Connection No.2 latest error code	This register stores the connection No.2 latest error code.	R
SD10132	Connection No.3 latest error code	This register stores the connection No.3 latest error code.	R
SD10133	Connection No.4 latest error code	This register stores the connection No.4 latest error code.	R
SD10134	Connection No.5 latest error code	This register stores the connection No.5 latest error code.	R
SD10135	Connection No.6 latest error code	This register stores the connection No.6 latest error code.	R
SD10136	Connection No.7 latest error code	This register stores the connection No.7 latest error code.	R
SD10137	Connection No.8 latest error code	This register stores the connection No.8 latest error code.	R
SD10270	Remote password lock status connection No. 1 to 8	b0: Connection No.1 b1: Connection No.2 b2: Connection No.3 b3: Connection No.4 b4: Connection No.5 b5: Connection No.6 b6: Connection No.7 b7: Connection No.8 0: Unlock status/remote password setting none 1: Lock status	R

No.	Name	Description	R/W
SD10271	Remote password lock status system port	b2: MELSOFT application communication port (TCP) b3: MELSOFT direct connection 0: Unlock status/remote password setting none 1: Lock status	R
SD10320	Connection 1 continuous unlock failure number of times	This register stores the connection 1 continuous unlock failure number of times.	R
SD10321	Connection 2 continuous unlock failure number of times	This register stores the connection 2 continuous unlock failure number of times.	R
SD10322	Connection 3 continuous unlock failure number of times	This register stores the connection 3 continuous unlock failure number of times.	R
SD10323	Connection 4 continuous unlock failure number of times	This register stores the connection 4 continuous unlock failure number of times.	R
SD10324	Connection 5 continuous unlock failure number of times	This register stores the connection 5 continuous unlock failure number of times.	R
SD10325	Connection 6 continuous unlock failure number of times	This register stores the connection 6 continuous unlock failure number of times.	R
SD10326	Connection 7 continuous unlock failure number of times	This register stores the connection 7 continuous unlock failure number of times.	R
SD10327	Connection 8 continuous unlock failure number of times	This register stores the connection 8 continuous unlock failure number of times.	R
SD10338	MELSOFT communication port (TCP/IP) continuous unlock failure number of times	This register stores the MELSOFT communication port (TCP/IP) continuous unlock failure number of times.	R
SD10340	MELSOFT direct connection continuous unlock failure number of times	This register stores the MELSOFT direct connection continuous unlock failure number of times.	R
SD10680	Open completion signal	b0: Connection No.1 b1: Connection No.2 b2: Connection No.3 b3: Connection No.4 b4: Connection No.5 b5: Connection No.6 b6: Connection No.7 b7: Connection No.8 0: Close/Open not completed 1: Open completed	R
SD10681	Open request signal	b0: Connection No.1 b1: Connection No.2 b2: Connection No.3 b3: Connection No.4 b4: Connection No.5 b5: Connection No.6 b6: Connection No.7 b7: Connection No.8 0: No open request 1: Open request exists	R
SD10682	Socket communications receive status signal	b0: Connection No.1 b1: Connection No.2 b2: Connection No.3 b3: Connection No.4 b4: Connection No.5 b5: Connection No.6 b6: Connection No.7 b7: Connection No.8 0: No data received 1: Data receiving completed	R
SD10692	Predefined protocol ready	0: — 1: Ready	R
SD10710	Predefined protocol setting data error information protocol number	When a protocol setting data error is detected, stores the protocol number where the error was detected.	R
SD10711	Predefined protocol setting data error information setting type	0 is stored if an error is detected in the packet setting or element setting. 1 is stored if an error is detected in the protocol detailed setting.	R
SD10712	Predefined protocol setting data error information packet number	When an error is detected in the protocol setting data, stores the packet number that detected the error.	R
SD10713	Predefined protocol setting data error information Element number	When an error is detected in the protocol setting data, stores the element number where the error was detected.	R

No.	Name	Description	R/W
SD10714	Number of registered predefined protocols	Stores the protocol number of the registered protocol setting data.	R
SD10722	Predefined protocol registration (1 to 16)	Whether protocol setting data is registered or not is stored.	R
SD10723	Predefined protocol registration (17 to 32)		
SD10724	Predefined protocol registration (33 to 48)		
SD10725	Predefined protocol registration (49 to 64)		
SD10740	Connection No.1 protocol execution status	Stores the status of the protocol being executed at connection No.1. 0: Unexecuted 1: Waiting for transmission 2: Sending 3: Waiting for data reception 4: Receiving 5: Execution completed	R
SD10742	Connection No.1 received data verification result (receive packet No.1)	Stores the verification results of receive packet No.1. Element No. where the verification result did not match (b0 to b7) The cause of mismatch (verification result code) (b8 to b15)	R
SD10743	Connection No.1 received data verification result (receive packet No.2)	Stores the verification results of receive packet No.2. Element No. where the verification result did not match (b0 to b7) The cause of mismatch (verification result code) (b8 to b15)	R
SD10744	Connection No.1 received data verification result (receive packet No.3)	Stores the verification results of receive packet No.3. Element No. where the verification result did not match (b0 to b7) The cause of mismatch (verification result code) (b8 to b15)	R
SD10745	Connection No.1 received data verification result (receive packet No.4)	Stores the verification results of receive packet No.4. Element No. where the verification result did not match (b0 to b7) The cause of mismatch (verification result code) (b8 to b15)	R
SD10746	Connection No.1 received data verification result (receive packet No.5)	Stores the verification results of receive packet No.5. Element No. where the verification result did not match (b0 to b7) The cause of mismatch (verification result code) (b8 to b15)	R
SD10747	Connection No.1 received data verification result (receive packet No.6)	Stores the verification results of receive packet No.6. Element No. where the verification result did not match (b0 to b7) The cause of mismatch (verification result code) (b8 to b15)	R
SD10748	Connection No.1 received data verification result (receive packet No.7)	Stores the verification results of receive packet No.7. Element No. where the verification result did not match (b0 to b7) The cause of mismatch (verification result code) (b8 to b15)	R
SD10749	Connection No.1 received data verification result (receive packet No.8)	Stores the verification results of receive packet No.8. Element No. where the verification result did not match (b0 to b7) The cause of mismatch (verification result code) (b8 to b15)	R
SD10750	Connection No.1 received data verification result (receive packet No.9)	Stores the verification results of receive packet No.9. Element No. where the verification result did not match (b0 to b7) The cause of mismatch (verification result code) (b8 to b15)	R
SD10751	Connection No.1 received data verification result (receive packet No.10)	Stores the verification results of receive packet No.10. Element No. where the verification result did not match (b0 to b7) The cause of mismatch (verification result code) (b8 to b15)	R
SD10752	Connection No.1 received data verification result (receive packet No.11)	Stores the verification results of receive packet No.11. Element No. where the verification result did not match (b0 to b7) The cause of mismatch (verification result code) (b8 to b15)	R
SD10753	Connection No.1 received data verification result (receive packet No.12)	Stores the verification results of receive packet No.12. Element No. where the verification result did not match (b0 to b7) The cause of mismatch (verification result code) (b8 to b15)	R
SD10754	Connection No.1 received data verification result (receive packet No.13)	Stores the verification results of receive packet No.13. Element No. where the verification result did not match (b0 to b7) The cause of mismatch (verification result code) (b8 to b15)	R
SD10755	Connection No.1 received data verification result (receive packet No.14)	Stores the verification results of receive packet No.14. Element No. where the verification result did not match (b0 to b7) The cause of mismatch (verification result code) (b8 to b15)	R
SD10756	Connection No.1 received data verification result (receive packet No.15)	Stores the verification results of receive packet No.15. Element No. where the verification result did not match (b0 to b7) The cause of mismatch (verification result code) (b8 to b15)	R
SD10757	Connection No.1 received data verification result (receive packet No.16)	Stores the verification results of receive packet No.16. Element No. where the verification result did not match (b0 to b7) The cause of mismatch (verification result code) (b8 to b15)	R

No.	Name	Description	R/W
SD10758	Connection No.1 protocol execution count	Stores the number of protocol executions in Connection No.1. 0: Protocol not executed 1 to 65535: Number of executions	R
SD10759	Connection No.1 protocol cancellation specification	Cancels the protocol executed in connection No.1. 0: No cancellation instruction 1: Cancellation request (set by user) 2: Cancellation completed (set by system)	R/W
SD10760	Connection No.2 protocol execution status	Stores the status of the protocol being executed at connection No.2. 0: Unexecuted 1: Waiting for transmission 2: Sending 3: Waiting for data reception 4: Receiving 5: Execution completed	R
SD10762	Connection No.2 received data verification result (receive packet No.1)	Stores the verification results of receive packet No.1. Element No. where the verification result did not match (b0 to b7) The cause of mismatch (verification result code) (b8 to b15)	R
SD10763	Connection No.2 received data verification result (receive packet No.2)	Stores the verification results of receive packet No.2. Element No. where the verification result did not match (b0 to b7) The cause of mismatch (verification result code) (b8 to b15)	R
SD10764	Connection No.2 received data verification result (receive packet No.3)	Stores the verification results of receive packet No.3. Element No. where the verification result did not match (b0 to b7) The cause of mismatch (verification result code) (b8 to b15)	R
SD10765	Connection No.2 received data verification result (receive packet No.4)	Stores the verification results of receive packet No.4. Element No. where the verification result did not match (b0 to b7) The cause of mismatch (verification result code) (b8 to b15)	R
SD10766	Connection No.2 received data verification result (receive packet No.5)	Stores the verification results of receive packet No.5. Element No. where the verification result did not match (b0 to b7) The cause of mismatch (verification result code) (b8 to b15)	R
SD10767	Connection No.2 received data verification result (receive packet No.6)	Stores the verification results of receive packet No.6. Element No. where the verification result did not match (b0 to b7) The cause of mismatch (verification result code) (b8 to b15)	R
SD10768	Connection No.2 received data verification result (receive packet No.7)	Stores the verification results of receive packet No.7. Element No. where the verification result did not match (b0 to b7) The cause of mismatch (verification result code) (b8 to b15)	R
SD10769	Connection No.2 received data verification result (receive packet No.8)	Stores the verification results of receive packet No.8. Element No. where the verification result did not match (b0 to b7) The cause of mismatch (verification result code) (b8 to b15)	R
SD10770	Connection No.2 received data verification result (receive packet No.9)	Stores the verification results of receive packet No.9. Element No. where the verification result did not match (b0 to b7) The cause of mismatch (verification result code) (b8 to b15)	R
SD10771	Connection No.2 received data verification result (receive packet No.10)	Stores the verification results of receive packet No.10. Element No. where the verification result did not match (b0 to b7) The cause of mismatch (verification result code) (b8 to b15)	R
SD10772	Connection No.2 received data verification result (receive packet No.11)	Stores the verification results of receive packet No.11. Element No. where the verification result did not match (b0 to b7) The cause of mismatch (verification result code) (b8 to b15)	R
SD10773	Connection No.2 received data verification result (receive packet No.12)	Stores the verification results of receive packet No.12. Element No. where the verification result did not match (b0 to b7) The cause of mismatch (verification result code) (b8 to b15)	R
SD10774	Connection No.2 received data verification result (receive packet No.13)	Stores the verification results of receive packet No.13. Element No. where the verification result did not match (b0 to b7) The cause of mismatch (verification result code) (b8 to b15)	R
SD10775	Connection No.2 received data verification result (receive packet No.14)	Stores the verification results of receive packet No.14. Element No. where the verification result did not match (b0 to b7) The cause of mismatch (verification result code) (b8 to b15)	R
SD10776	Connection No.2 received data verification result (receive packet No.15)	Stores the verification results of receive packet No.15. Element No. where the verification result did not match (b0 to b7) The cause of mismatch (verification result code) (b8 to b15)	R
SD10777	Connection No.2 received data verification result (receive packet No.16)	Stores the verification results of receive packet No.16. Element No. where the verification result did not match (b0 to b7) The cause of mismatch (verification result code) (b8 to b15)	R

No.	Name	Description	R/W
SD10778	Connection No.2 protocol execution count	Stores the number of protocol executions in connection No.2. 0: Protocol not executed 1 to 65535: Number of executions	R
SD10779	Connection No.2 protocol cancellation specification	Cancels the protocol executed in connection No.2. 0: No cancellation instruction 1: Cancellation request (set by user) 2: Cancellation completed (set by system)	R/W
SD10780	Connection No.3 protocol execution status	Stores the status of the protocol being executed at connection No.3. 0: Unexecuted 1: Waiting for transmission 2: Sending 3: Waiting for data reception 4: Receiving 5: Execution completed	R
SD10782	Connection No.3 received data verification result (receive packet No.1)	Stores the verification results of receive packet No.1. Element No. where the verification result did not match (b0 to b7) The cause of mismatch (verification result code) (b8 to b15)	R
SD10783	Connection No.3 received data verification result (receive packet No.2)	Stores the verification results of receive packet No.2. Element No. where the verification result did not match (b0 to b7) The cause of mismatch (verification result code) (b8 to b15)	R
SD10784	Connection No.3 received data verification result (receive packet No.3)	Stores the verification results of receive packet No.3. Element No. where the verification result did not match (b0 to b7) The cause of mismatch (verification result code) (b8 to b15)	R
SD10785	Connection No.3 received data verification result (receive packet No.4)	Stores the verification results of receive packet No.4. Element No. where the verification result did not match (b0 to b7) The cause of mismatch (verification result code) (b8 to b15)	R
SD10786	Connection No.3 received data verification result (receive packet No.5)	Stores the verification results of receive packet No.5. Element No. where the verification result did not match (b0 to b7) The cause of mismatch (verification result code) (b8 to b15)	R
SD10787	Connection No.3 received data verification result (receive packet No.6)	Stores the verification results of receive packet No.6. Element No. where the verification result did not match (b0 to b7) The cause of mismatch (verification result code) (b8 to b15)	R
SD10788	Connection No.3 received data verification result (receive packet No.7)	Stores the verification results of receive packet No.7. Element No. where the verification result did not match (b0 to b7) The cause of mismatch (verification result code) (b8 to b15)	R
SD10789	Connection No.3 received data verification result (receive packet No.8)	Stores the verification results of receive packet No.8. Element No. where the verification result did not match (b0 to b7) The cause of mismatch (verification result code) (b8 to b15)	R
SD10790	Connection No.3 received data verification result (receive packet No.9)	Stores the verification results of receive packet No.9. Element No. where the verification result did not match (b0 to b7) The cause of mismatch (verification result code) (b8 to b15)	R
SD10791	Connection No.3 received data verification result (receive packet No.10)	Stores the verification results of receive packet No.10. Element No. where the verification result did not match (b0 to b7) The cause of mismatch (verification result code) (b8 to b15)	R
SD10792	Connection No.3 received data verification result (receive packet No.11)	Stores the verification results of receive packet No.11. Element No. where the verification result did not match (b0 to b7) The cause of mismatch (verification result code) (b8 to b15)	R
SD10793	Connection No.3 received data verification result (receive packet No.12)	Stores the verification results of receive packet No.12. Element No. where the verification result did not match (b0 to b7) The cause of mismatch (verification result code) (b8 to b15)	R
SD10794	Connection No.3 received data verification result (receive packet No.13)	Stores the verification results of receive packet No.13. Element No. where the verification result did not match (b0 to b7) The cause of mismatch (verification result code) (b8 to b15)	R
SD10795	Connection No.3 received data verification result (receive packet No.14)	Stores the verification results of receive packet No.14. Element No. where the verification result did not match (b0 to b7) The cause of mismatch (verification result code) (b8 to b15)	R
SD10796	Connection No.3 received data verification result (receive packet No.15)	Stores the verification results of receive packet No.15. Element No. where the verification result did not match (b0 to b7) The cause of mismatch (verification result code) (b8 to b15)	R
SD10797	Connection No.3 received data verification result (receive packet No.16)	Stores the verification results of receive packet No.16. Element No. where the verification result did not match (b0 to b7) The cause of mismatch (verification result code) (b8 to b15)	R

No.	Name	Description	R/W
SD10798	Connection No.3 protocol execution count	Stores the number of protocol executions in connection No.3. 0: Protocol not executed 1 to 65535: Number of executions	R
SD10799	Connection No.3 protocol cancellation specification	Cancels the protocol executed in connection No.3. 0: No cancellation instruction 1: Cancellation request (set by user) 2: Cancellation completed (set by system)	R/W
SD10800	Connection No.4 protocol execution status	Stores the status of the protocol being executed at connection No.4. 0: Unexecuted 1: Waiting for transmission 2: Sending 3: Waiting for data reception 4: Receiving 5: Execution completed	R
SD10802	Connection No.4 received data verification result (receive packet No.1)	Stores the verification results of receive packet No.1. Element No. where the verification result did not match (b0 to b7) The cause of mismatch (verification result code) (b8 to b15)	R
SD10803	Connection No.4 received data verification result (receive packet No.2)	Stores the verification results of receive packet No.2. Element No. where the verification result did not match (b0 to b7) The cause of mismatch (verification result code) (b8 to b15)	R
SD10804	Connection No.4 received data verification result (receive packet No.3)	Stores the verification results of receive packet No.3. Element No. where the verification result did not match (b0 to b7) The cause of mismatch (verification result code) (b8 to b15)	R
SD10805	Connection No.4 received data verification result (receive packet No.4)	Stores the verification results of receive packet No.4. Element No. where the verification result did not match (b0 to b7) The cause of mismatch (verification result code) (b8 to b15)	R
SD10806	Connection No.4 received data verification result (receive packet No.5)	Stores the verification results of receive packet No.5. Element No. where the verification result did not match (b0 to b7) The cause of mismatch (verification result code) (b8 to b15)	R
SD10807	Connection No.4 received data verification result (receive packet No.6)	Stores the verification results of receive packet No.6. Element No. where the verification result did not match (b0 to b7) The cause of mismatch (verification result code) (b8 to b15)	R
SD10808	Connection No.4 received data verification result (receive packet No.7)	Stores the verification results of receive packet No.7. Element No. where the verification result did not match (b0 to b7) The cause of mismatch (verification result code) (b8 to b15)	R
SD10809	Connection No.4 received data verification result (receive packet No.8)	Stores the verification results of receive packet No.8. Element No. where the verification result did not match (b0 to b7) The cause of mismatch (verification result code) (b8 to b15)	R
SD10810	Connection No.4 received data verification result (receive packet No.9)	Stores the verification results of receive packet No.9. Element No. where the verification result did not match (b0 to b7) The cause of mismatch (verification result code) (b8 to b15)	R
SD10811	Connection No.4 received data verification result (receive packet No.10)	Stores the verification results of receive packet No.10. Element No. where the verification result did not match (b0 to b7) The cause of mismatch (verification result code) (b8 to b15)	R
SD10812	Connection No.4 received data verification result (receive packet No.11)	Stores the verification results of receive packet No.11. Element No. where the verification result did not match (b0 to b7) The cause of mismatch (verification result code) (b8 to b15)	R
SD10813	Connection No.4 received data verification result (receive packet No.12)	Stores the verification results of receive packet No.12. Element No. where the verification result did not match (b0 to b7) The cause of mismatch (verification result code) (b8 to b15)	R
SD10814	Connection No.4 received data verification result (receive packet No.13)	Stores the verification results of receive packet No.13. Element No. where the verification result did not match (b0 to b7) The cause of mismatch (verification result code) (b8 to b15)	R
SD10815	Connection No.4 received data verification result (receive packet No.14)	Stores the verification results of receive packet No.14. Element No. where the verification result did not match (b0 to b7) The cause of mismatch (verification result code) (b8 to b15)	R
SD10816	Connection No.4 received data verification result (receive packet No.15)	Stores the verification results of receive packet No.15. Element No. where the verification result did not match (b0 to b7) The cause of mismatch (verification result code) (b8 to b15)	R
SD10817	Connection No.4 received data verification result (receive packet No.16)	Stores the verification results of receive packet No.16. Element No. where the verification result did not match (b0 to b7) The cause of mismatch (verification result code) (b8 to b15)	R

No.	Name	Description	R/W
SD10818	Connection No.4 protocol execution count	Stores the number of protocol executions in connection No.4. 0: Protocol not executed 1 to 65535: Number of executions	R
SD10819	Connection No.4 protocol cancellation specification	Cancels the protocol executed in connection No.4. 0: No cancellation instruction 1: Cancellation request (set by user) 2: Cancellation completed (set by system)	R/W
SD10820	Connection No.5 protocol execution status	Stores the status of the protocol being executed at connection No.5. 0: Unexecuted 1: Waiting for transmission 2: Sending 3: Waiting for data reception 4: Receiving 5: Execution completed	R
SD10822	Connection No.5 received data verification result (receive packet No.1)	Stores the verification results of receive packet No.1. Element No. where the verification result did not match (b0 to b7) The cause of mismatch (verification result code) (b8 to b15)	R
SD10823	Connection No.5 received data verification result (receive packet No.2)	Stores the verification results of receive packet No.2. Element No. where the verification result did not match (b0 to b7) The cause of mismatch (verification result code) (b8 to b15)	R
SD10824	Connection No.5 received data verification result (receive packet No.3)	Stores the verification results of receive packet No.3. Element No. where the verification result did not match (b0 to b7) The cause of mismatch (verification result code) (b8 to b15)	R
SD10825	Connection No.5 received data verification result (receive packet No.4)	Stores the verification results of receive packet No.4. Element No. where the verification result did not match (b0 to b7) The cause of mismatch (verification result code) (b8 to b15)	R
SD10826	Connection No.5 received data verification result (receive packet No.5)	Stores the verification results of receive packet No.5. Element No. where the verification result did not match (b0 to b7) The cause of mismatch (verification result code) (b8 to b15)	R
SD10827	Connection No.5 received data verification result (receive packet No.6)	Stores the verification results of receive packet No.6. Element No. where the verification result did not match (b0 to b7) The cause of mismatch (verification result code) (b8 to b15)	R
SD10828	Connection No.5 received data verification result (receive packet No.7)	Stores the verification results of receive packet No.7. Element No. where the verification result did not match (b0 to b7) The cause of mismatch (verification result code) (b8 to b15)	R
SD10829	Connection No.5 received data verification result (receive packet No.8)	Stores the verification results of receive packet No.8. Element No. where the verification result did not match (b0 to b7) The cause of mismatch (verification result code) (b8 to b15)	R
SD10830	Connection No.5 received data verification result (receive packet No.9)	Stores the verification results of receive packet No.9. Element No. where the verification result did not match (b0 to b7) The cause of mismatch (verification result code) (b8 to b15)	R
SD10831	Connection No.5 received data verification result (receive packet No.10)	Stores the verification results of receive packet No.10. Element No. where the verification result did not match (b0 to b7) The cause of mismatch (verification result code) (b8 to b15)	R
SD10832	Connection No.5 received data verification result (receive packet No.11)	Stores the verification results of receive packet No.11. Element No. where the verification result did not match (b0 to b7) The cause of mismatch (verification result code) (b8 to b15)	R
SD10833	Connection No.5 received data verification result (receive packet No.12)	Stores the verification results of receive packet No.12. Element No. where the verification result did not match (b0 to b7) The cause of mismatch (verification result code) (b8 to b15)	R
SD10834	Connection No.5 received data verification result (receive packet No.13)	Stores the verification results of receive packet No.13. Element No. where the verification result did not match (b0 to b7) The cause of mismatch (verification result code) (b8 to b15)	R
SD10835	Connection No.5 received data verification result (receive packet No.14)	Stores the verification results of receive packet No.14. Element No. where the verification result did not match (b0 to b7) The cause of mismatch (verification result code) (b8 to b15)	R
SD10836	Connection No.5 received data verification result (receive packet No.15)	Stores the verification results of receive packet No.15. Element No. where the verification result did not match (b0 to b7) The cause of mismatch (verification result code) (b8 to b15)	R
SD10837	Connection No.5 received data verification result (receive packet No.16)	Stores the verification results of receive packet No.16. Element No. where the verification result did not match (b0 to b7) The cause of mismatch (verification result code) (b8 to b15)	R

No.	Name	Description	R/W
SD10838	Connection No.5 protocol execution count	Stores the number of protocol executions in connection No.5. 0: Protocol not executed 1 to 65535: Number of executions	R
SD10839	Connection No.5 protocol cancellation specification	Cancels the protocol executed in connection No.5. 0: No cancellation instruction 1: Cancellation request (set by user) 2: Cancellation completed (set by system)	R/W
SD10840	Connection No.6 protocol execution status	Stores the status of the protocol being executed at connection No.6. 0: Unexecuted 1: Waiting for transmission 2: Sending 3: Waiting for data reception 4: Receiving 5: Execution completed	R
SD10842	Connection No.6 received data verification result (receive packet No.1)	Stores the verification results of receive packet No.1. Element No. where the verification result did not match (b0 to b7) The cause of mismatch (verification result code) (b8 to b15)	R
SD10843	Connection No.6 received data verification result (receive packet No.2)	Stores the verification results of receive packet No.2. Element No. where the verification result did not match (b0 to b7) The cause of mismatch (verification result code) (b8 to b15)	R
SD10844	Connection No.6 received data verification result (receive packet No.3)	Stores the verification results of receive packet No.3. Element No. where the verification result did not match (b0 to b7) The cause of mismatch (verification result code) (b8 to b15)	R
SD10845	Connection No.6 received data verification result (receive packet No.4)	Stores the verification results of receive packet No.4. Element No. where the verification result did not match (b0 to b7) The cause of mismatch (verification result code) (b8 to b15)	R
SD10846	Connection No.6 received data verification result (receive packet No.5)	Stores the verification results of receive packet No.5. Element No. where the verification result did not match (b0 to b7) The cause of mismatch (verification result code) (b8 to b15)	R
SD10847	Connection No.6 received data verification result (receive packet No.6)	Stores the verification results of receive packet No.6. Element No. where the verification result did not match (b0 to b7) The cause of mismatch (verification result code) (b8 to b15)	R
SD10848	Connection No.6 received data verification result (receive packet No.7)	Stores the verification results of receive packet No.7. Element No. where the verification result did not match (b0 to b7) The cause of mismatch (verification result code) (b8 to b15)	R
SD10849	Connection No.6 received data verification result (receive packet No.8)	Stores the verification results of receive packet No.8. Element No. where the verification result did not match (b0 to b7) The cause of mismatch (verification result code) (b8 to b15)	R
SD10850	Connection No.6 received data verification result (receive packet No.9)	Stores the verification results of receive packet No.9. Element No. where the verification result did not match (b0 to b7) The cause of mismatch (verification result code) (b8 to b15)	R
SD10851	Connection No.6 received data verification result (receive packet No.10)	Stores the verification results of receive packet No.10. Element No. where the verification result did not match (b0 to b7) The cause of mismatch (verification result code) (b8 to b15)	R
SD10852	Connection No.6 received data verification result (receive packet No.11)	Stores the verification results of receive packet No.11. Element No. where the verification result did not match (b0 to b7) The cause of mismatch (verification result code) (b8 to b15)	R
SD10853	Connection No.6 received data verification result (receive packet No.12)	Stores the verification results of receive packet No.12. Element No. where the verification result did not match (b0 to b7) The cause of mismatch (verification result code) (b8 to b15)	R
SD10854	Connection No.6 received data verification result (receive packet No.13)	Stores the verification results of receive packet No.13. Element No. where the verification result did not match (b0 to b7) The cause of mismatch (verification result code) (b8 to b15)	R
SD10855	Connection No.6 received data verification result (receive packet No.14)	Stores the verification results of receive packet No.14. Element No. where the verification result did not match (b0 to b7) The cause of mismatch (verification result code) (b8 to b15)	R
SD10856	Connection No.6 received data verification result (receive packet No.15)	Stores the verification results of receive packet No.15. Element No. where the verification result did not match (b0 to b7) The cause of mismatch (verification result code) (b8 to b15)	R
SD10857	Connection No.6 received data verification result (receive packet No.16)	Stores the verification results of receive packet No.16. Element No. where the verification result did not match (b0 to b7) The cause of mismatch (verification result code) (b8 to b15)	R

No.	Name	Description	R/W
SD10858	Connection No.6 protocol execution count	Stores the number of protocol executions in connection No.6. 0: Protocol not executed 1 to 65535: Number of executions	R
SD10859	Connection No.6 protocol cancellation specification	Cancels the protocol executed in connection No.6. 0: No cancellation instruction 1: Cancellation request (set by user) 2: Cancellation completed (set by system)	R/W
SD10860	Connection No.7 protocol execution status	Stores the status of the protocol being executed at connection No.7. 0: Unexecuted 1: Waiting for transmission 2: Sending 3: Waiting for data reception 4: Receiving 5: Execution completed	R
SD10862	Connection No.7 received data verification result (receive packet No.1)	Stores the verification results of receive packet No.1. Element No. where the verification result did not match (b0 to b7) The cause of mismatch (verification result code) (b8 to b15)	R
SD10863	Connection No.7 received data verification result (receive packet No.2)	Stores the verification results of receive packet No.2. Element No. where the verification result did not match (b0 to b7) The cause of mismatch (verification result code) (b8 to b15)	R
SD10864	Connection No.7 received data verification result (receive packet No.3)	Stores the verification results of receive packet No.3. Element No. where the verification result did not match (b0 to b7) The cause of mismatch (verification result code) (b8 to b15)	R
SD10865	Connection No.7 received data verification result (receive packet No.4)	Stores the verification results of receive packet No.4. Element No. where the verification result did not match (b0 to b7) The cause of mismatch (verification result code) (b8 to b15)	R
SD10866	Connection No.7 received data verification result (receive packet No.5)	Stores the verification results of receive packet No.5. Element No. where the verification result did not match (b0 to b7) The cause of mismatch (verification result code) (b8 to b15)	R
SD10867	Connection No.7 received data verification result (receive packet No.6)	Stores the verification results of receive packet No.6. Element No. where the verification result did not match (b0 to b7) The cause of mismatch (verification result code) (b8 to b15)	R
SD10868	Connection No.7 received data verification result (receive packet No.7)	Stores the verification results of receive packet No.7. Element No. where the verification result did not match (b0 to b7) The cause of mismatch (verification result code) (b8 to b15)	R
SD10869	Connection No.7 received data verification result (receive packet No.8)	Stores the verification results of receive packet No.8. Element No. where the verification result did not match (b0 to b7) The cause of mismatch (verification result code) (b8 to b15)	R
SD10870	Connection No.7 received data verification result (receive packet No.9)	Stores the verification results of receive packet No.9. Element No. where the verification result did not match (b0 to b7) The cause of mismatch (verification result code) (b8 to b15)	R
SD10871	Connection No.7 received data verification result (receive packet No.10)	Stores the verification results of receive packet No.10. Element No. where the verification result did not match (b0 to b7) The cause of mismatch (verification result code) (b8 to b15)	R
SD10872	Connection No.7 received data verification result (receive packet No.11)	Stores the verification results of receive packet No.11. Element No. where the verification result did not match (b0 to b7) The cause of mismatch (verification result code) (b8 to b15)	R
SD10873	Connection No.7 received data verification result (receive packet No.12)	Stores the verification results of receive packet No.12. Element No. where the verification result did not match (b0 to b7) The cause of mismatch (verification result code) (b8 to b15)	R
SD10874	Connection No.7 received data verification result (receive packet No.13)	Stores the verification results of receive packet No.13. Element No. where the verification result did not match (b0 to b7) The cause of mismatch (verification result code) (b8 to b15)	R
SD10875	Connection No.7 received data verification result (receive packet No.14)	Stores the verification results of receive packet No.14. Element No. where the verification result did not match (b0 to b7) The cause of mismatch (verification result code) (b8 to b15)	R
SD10876	Connection No.7 received data verification result (receive packet No.15)	Stores the verification results of receive packet No.15. Element No. where the verification result did not match (b0 to b7) The cause of mismatch (verification result code) (b8 to b15)	R
SD10877	Connection No.7 received data verification result (receive packet No.16)	Stores the verification results of receive packet No.16. Element No. where the verification result did not match (b0 to b7) The cause of mismatch (verification result code) (b8 to b15)	R

No.	Name	Description	R/W
SD10878	Connection No.7 protocol execution count	Stores the number of protocol executions in connection No.7. 0: Protocol not executed 1 to 65535: Number of executions	R
SD10879	Connection No.7 protocol cancellation specification	Cancels the protocol executed in connection No.7. 0: No cancellation instruction 1: Cancellation request (set by user) 2: Cancellation completed (set by system)	R/W
SD10880	Connection No.8 protocol execution status	Stores the status of the protocol being executed at connection No.8. 0: Unexecuted 1: Waiting for transmission 2: Sending 3: Waiting for data reception 4: Receiving 5: Execution completed	R
SD10882	Connection No.8 received data verification result (receive packet No.1)	Stores the verification results of receive packet No.1. Element No. where the verification result did not match (b0 to b7) The cause of mismatch (verification result code) (b8 to b15)	R
SD10883	Connection No.8 received data verification result (receive packet No.2)	Stores the verification results of receive packet No.2. Element No. where the verification result did not match (b0 to b7) The cause of mismatch (verification result code) (b8 to b15)	R
SD10884	Connection No.8 received data verification result (receive packet No.3)	Stores the verification results of receive packet No.3. Element No. where the verification result did not match (b0 to b7) The cause of mismatch (verification result code) (b8 to b15)	R
SD10885	Connection No.8 received data verification result (receive packet No.4)	Stores the verification results of receive packet No.4. Element No. where the verification result did not match (b0 to b7) The cause of mismatch (verification result code) (b8 to b15)	R
SD10886	Connection No.8 received data verification result (receive packet No.5)	Stores the verification results of receive packet No.5. Element No. where the verification result did not match (b0 to b7) The cause of mismatch (verification result code) (b8 to b15)	R
SD10887	Connection No.8 received data verification result (receive packet No.6)	Stores the verification results of receive packet No.6. Element No. where the verification result did not match (b0 to b7) The cause of mismatch (verification result code) (b8 to b15)	R
SD10888	Connection No.8 received data verification result (receive packet No.7)	Stores the verification results of receive packet No.7. Element No. where the verification result did not match (b0 to b7) The cause of mismatch (verification result code) (b8 to b15)	R
SD10889	Connection No.8 received data verification result (receive packet No.8)	Stores the verification results of receive packet No.8. Element No. where the verification result did not match (b0 to b7) The cause of mismatch (verification result code) (b8 to b15)	R
SD10890	Connection No.8 received data verification result (receive packet No.9)	Stores the verification results of receive packet No.9. Element No. where the verification result did not match (b0 to b7) The cause of mismatch (verification result code) (b8 to b15)	R
SD10891	Connection No.8 received data verification result (receive packet No.10)	Stores the verification results of receive packet No.10. Element No. where the verification result did not match (b0 to b7) The cause of mismatch (verification result code) (b8 to b15)	R
SD10892	Connection No.8 received data verification result (receive packet No.11)	Stores the verification results of receive packet No.11. Element No. where the verification result did not match (b0 to b7) The cause of mismatch (verification result code) (b8 to b15)	R
SD10893	Connection No.8 received data verification result (receive packet No.12)	Stores the verification results of receive packet No.12. Element No. where the verification result did not match (b0 to b7) The cause of mismatch (verification result code) (b8 to b15)	R
SD10894	Connection No.8 received data verification result (receive packet No.13)	Stores the verification results of receive packet No.13. Element No. where the verification result did not match (b0 to b7) The cause of mismatch (verification result code) (b8 to b15)	R
SD10895	Connection No.8 received data verification result (receive packet No.14)	Stores the verification results of receive packet No.14. Element No. where the verification result did not match (b0 to b7) The cause of mismatch (verification result code) (b8 to b15)	R
SD10896	Connection No.8 received data verification result (receive packet No.15)	Stores the verification results of receive packet No.15. Element No. where the verification result did not match (b0 to b7) The cause of mismatch (verification result code) (b8 to b15)	R
SD10897	Connection No.8 received data verification result (receive packet No.16)	Stores the verification results of receive packet No.16. Element No. where the verification result did not match (b0 to b7) The cause of mismatch (verification result code) (b8 to b15)	R

No.	Name	Description	R/W
SD10898	Connection No.8 protocol execution count	Stores the number of protocol executions in connection No.8. 0: Protocol not executed 1 to 65535: Number of executions	R
SD10899	Connection No.8 protocol cancellation specification	Cancels the protocol executed in connection No.8. 0: No cancellation instruction 1: Cancellation request (set by user) 2: Cancellation completed (set by system)	R/W

Appendix 3 Error Code

The CPU module stores error code in special register (SD) upon detection of an error using the self-diagnostics function. The error details and cause can be identified by checking the error code. The error code can be checked in either of the following ways.

- Module diagnostics of engineering tool (📖 MELSEC iQ-F FX5 User's Manual (Startup))
- Special register (SD0 (latest self-diagnostics error code), SD10 to SD25 (self-diagnostics error code)) (📖 Page 240 Special Register List)

This section describes errors that may occur in the CPU module and actions to be taken for the errors.

Error code system

All error codes are given in hexadecimal format (4 digits) (16-bit unsigned integer). The following table lists the error detection type and the error code ranges.

Error detection type	Range	Description
Detection by the self-diagnostics function of each module	0001H to 3FFFH	Error code specific to each module, such as self-diagnostics errors
Detected during communication between CPU modules	4000H to 4FFFH	CPU module error
	7000H to 7FFFH	📖 MELSEC iQ-F FX5 User's Manual (Serial Communication) 📖 MELSEC iQ-F FX5 User's Manual (MODBUS Communication)
	C000H to CFFFH	📖 MELSEC iQ-F FX5 User's Manual (Ethernet Communication)

Detailed information

Upon detection of error through self-diagnostics function, the detailed information of the error cause is stored all together. The following detailed information is added to each error code (up to two types of information are stored for each error code. The types differ depending on error code.) Detailed information 1 to 2 of the latest error code(s) can be checked with special register (SD).

Detailed information	Item	Description
Detailed information 1	Error location information*1	Information on the location in a program
	Drive/File information	Information on drive names and file names
	Parameter information	The information for the parameter, such as parameter storage location and parameter type, is indicated.
	System configuration information	The information for the system configuration, such as I/O No is indicated.
	Frequency information	This section describes the information for frequency such as the write frequency into memory.
	Time information	The information for the time is indicated.
Detailed information 2	Drive/File information	Information on drive names and file names
	Annunciator information	Information about annunciators
	Parameter information	The information for the parameter, such as parameter storage location and parameter type, is indicated.
	System configuration information	The information for the system configuration, such as I/O No is indicated.

*1 The step No, which is displayed in the program position information, is the step No that is counted from the head of the file. It might be sometimes different from the step No of the program which is displayed in error jump of engineering tool.

Operation when an error occurs

There are two types of errors: continuation errors and stop errors.

Stop error

If a stop error occurs, the CPU module stops its operation and the operating state will be in STOP. Modules can communicate with the CPU module even after a stop error occurs in the CPU module.

Continuation error

If a continuation error occurs, the CPU module continues its operation. (The operating state will remain the same.)

How to clear errors

Continuation errors can be cleared. (☞ Page 112 Error Clear)

List of error codes

Self-diagnostics error codes of the CPU module (1000H to 3FFFH)

The following table lists the error codes detected by the self-diagnostics function of the CPU module.

Error code	Error name	Error details and cause	Action	Detailed information	Diagnostic timing
1080H	ROM write count error	• The number of writes to the data memory exceeded 20,000 times.	• Replace the CPU module.	Frequency information	At write
1090H	Battery error	• Low battery voltage was detected. An error was also detected in a battery latched (backed) device.	• Check the connection of the battery. • Replace the battery as soon as possible.	—	At END instruction execution
1130H	IP address duplication error	• Overlapping IP addresses were detected.	• Check the IP address.	—	—
1800H	Annunciator ON	• An annunciator that was turned ON by the SET F instruction or OUT F instruction was detected.	• Check the program of that number (annunciator number).	Error location information and annunciator information	At instruction execution
1810H	Operation error	• The channel specified by instructions using communication functions or built-in I/O is already used by other instructions.	• Verify that the channel specified by instructions using communication functions or built-in I/O is not used by other instructions.	Error location information	At instruction execution
1811H	Operation error	• The number of times that applied instructions are used in the program exceeded the specified limit.	• Verify that the number of times that applied instructions are used in the program does not exceed the specified limit.	Error location information	At instruction execution
1900H	Constant scan time error	• The scan time exceeded the constant scan setting value.	• Check and correct the constant scan time setting. Recheck the setting time of the constant scan.	Time information	At END instruction execution
1920H	IP address setting error	• Values such as the IP address setting (SD8492 to SD8497) are outside the set range.	• Recheck the values such as the IP address setting (SD8492 to SD8497).	—	At END instruction execution
1921H	IP address writing/clear request simultaneous detection	• Write request and clear request (M8492 and SM8495) turned from OFF to ON simultaneously.	• Verify that write request and clear request (SM8492 and MS8495) do not turn from OFF to ON simultaneously.	—	At END instruction execution
1930H	Online change error	• An error was detected when writing was executed during RUN.	• Set the CPU module to STOP and write a set of project data.	—	At END instruction execution
1931H	Online change error	• An error was detected when writing was executed during RUN.	• Set the CPU module to STOP and write a set of project data.	—	At END instruction execution
1FE0H	Module configuration error	• The number of I/O points specified in the I/O assignment setting of the parameters is different from that of the module connected.	• Make sure that the parameters are consistent with the connections.	System configuration information	At power-on, at RESET
1FE1H	Module configuration error	• The module position specified in the I/O assignment setting of the parameters is different from that of the module connected.	• Make sure that the parameters are consistent with the connections.	System configuration information	At power-on, at RESET
1FE2H	Module configuration error	• No parameters available for the module connected exist.	• Make sure that the parameters are consistent with the connections.	System configuration information	At power-on, at RESET
1FE3H	Module configuration error	• The module specified in the I/O assignment setting of the parameters is not connected.	• Make sure that the parameters are consistent with the connections.	System configuration information	At power-on, at RESET
1FE4H	Module configuration error	• Parameters for a standard input/output module are set to a high-speed input/output module.	• Make sure that the parameters are consistent with the connections.	System configuration information	At power-on, at RESET

Error code	Error name	Error details and cause	Action	Detailed information	Diagnostic timing
1FE5H	Module configuration error	<ul style="list-style-type: none"> The I/O numbers of the reserved module specified in the I/O assignment setting of the parameters overlap those of other modules. 	<ul style="list-style-type: none"> Make sure that the parameters are consistent with the connections. 	System configuration information	At power-on, at RESET
1FE6H	Module configuration error	<ul style="list-style-type: none"> The I/O method of the input/output module is different. 	<ul style="list-style-type: none"> Make sure that the parameters are consistent with the connections. 	System configuration information	At power-on, at RESET
1FE7H	Module configuration error	<ul style="list-style-type: none"> The type of the CPU module is different. 	<ul style="list-style-type: none"> Make sure that the parameters are consistent with the connections. 	System configuration information	At power-on, at RESET
2003H	Module configuration error	<ul style="list-style-type: none"> The model of the module connected is different from that of the module set in the parameters. 	<ul style="list-style-type: none"> Make sure the model of the module to be set is consistent with the parameters of the module connected. 	System configuration information	At power-on, at RESET
2008H	Module configuration error	<ul style="list-style-type: none"> The total number of I/O points (excluding remote I/O) exceeded 256. 	<ul style="list-style-type: none"> Do not use more than 256 I/O points in programs. 	System configuration information	At power-on, at RESET
2042H	CPU module configuration error	<ul style="list-style-type: none"> The number of input, output, input/output, and intelligent function modules connected is equal to or greater than 17. The number of communication adapters connected is equal to or greater than 3. The number of analog adapters connected is equal to or greater than 5. The number of extension power supply modules connected is equal to or greater than 3. The number of expansion boards connected is equal to or greater than 2. 	<ul style="list-style-type: none"> Use up to 16 input, output, input/output, and intelligent function modules. Use up to 2 communication adapters. Use up to 4 analog adapters. Use up to 2 extension power supply modules. Use up to 1 expansion board. 	System configuration information	At power-on, at RESET
20E0H	Invalid module detection	<ul style="list-style-type: none"> An unsupported module was detected. 	<ul style="list-style-type: none"> Verify that the version of the CPU module is compatible with the module where the error was detected. If the version of the CPU module is correct, there may be a malfunction in the connected module. Replace the connected module. 	System configuration information	At power-on, at RESET
2120H	Memory card error	<ul style="list-style-type: none"> An SD memory card error was detected. The SD memory card may have been removed without the SD memory card disabled. 	<ul style="list-style-type: none"> Check the connection of the SD memory card. If the problem persists, there may be a malfunction in the SD memory card or CPU module. 	Drive/file information	Always
2121H	Memory card error	<ul style="list-style-type: none"> An SD memory card error was detected. The SD memory card may not be correctly formatted. 	<ul style="list-style-type: none"> Format the SD memory card. If the problem persists, there may be a malfunction in the SD memory card or CPU module. 	Drive/file information	Always
2180H	Invalid file	<ul style="list-style-type: none"> An error was found in the data of the file. 	<ul style="list-style-type: none"> Recreate the file. 	Drive/file information	At power-on, at RESET, at STOP → RUN state
21A0H	File specification error	<ul style="list-style-type: none"> The file specified in the parameters does not exist. 	<ul style="list-style-type: none"> Rewrite the project. 	Drive/file information Parameter information	At power-on, at RESET, at STOP → RUN state
2220H	Parameter error	<ul style="list-style-type: none"> The contents of the parameters are corrupted. 	<ul style="list-style-type: none"> Rewrite the project. 	Parameter information	At power-on, at RESET
2221H	Parameter error	<ul style="list-style-type: none"> The parameter set value is out of range. 	<ul style="list-style-type: none"> Modify the parameter set value and rewrite the project. 	Parameter information	At power-on, at RESET
2222H	Parameter error	<ul style="list-style-type: none"> The parameter set value is out of range. 	<ul style="list-style-type: none"> Modify the parameter set value and rewrite the project. 	Parameter information	At power-on, at RESET
2241H	Parameter error (module)	<ul style="list-style-type: none"> The module parameter settings and the target module are different. 	<ul style="list-style-type: none"> Modify the module parameter set value and rewrite the project. 	Parameter information	At power-on, at RESET
2300H	Security key authentication error	<ul style="list-style-type: none"> The security key locking the program does not match the security key written in the CPU module. 	<ul style="list-style-type: none"> Write the correct security key to the CPU module. 	Drive/file information	At power-on, at RESET, at STOP → RUN state

Error code	Error name	Error details and cause	Action	Detailed information	Diagnostic timing
2301H	Security key authentication error	<ul style="list-style-type: none"> The program is locked by the security key, but the security key is not written in the CPU module. 	<ul style="list-style-type: none"> Write the security key to the CPU module. 	Drive/file information	At power-on, at RESET, at STOP → RUN state
2302H	Security key authentication error	<ul style="list-style-type: none"> The security key written in the CPU module is corrupted. 	<ul style="list-style-type: none"> Rewrite the security key to the CPU module. 	—	At power-on, at RESET, at STOP → RUN state
2320H	Remote password setting error	<ul style="list-style-type: none"> A module supporting remote passwords is not connected to the module number specified in the remote password parameter. 	<ul style="list-style-type: none"> Recheck the remote password parameter setting or module configuration. 	System configuration information	At power-on, at RESET
2400H	Module verification error	<ul style="list-style-type: none"> The power of a module connected is OFF or a connection error has been detected. 	<ul style="list-style-type: none"> Verify that the connected module is powered on. Verify that extension cables are correctly connected. Implement anti-noise measures. If there is no problem, there may be a malfunction in the connected module. Replace the connected module. 	System configuration information	Always
2401H	Module verification error	<ul style="list-style-type: none"> A module was connected during operation. 	<ul style="list-style-type: none"> Avoid connecting a module during operation. 	System configuration information	Always
2440H	Module major error	<ul style="list-style-type: none"> The communication procedure with a module failed during initial processing. 	<ul style="list-style-type: none"> Verify that extension cables are correctly connected. Verify that the version of the CPU module is compatible with the module where the error was detected. If the version of the CPU module is correct, there may be a malfunction in the connected module. Replace the connected module. 	System configuration information	At power-on, at RESET
2441H	Module major error	<ul style="list-style-type: none"> The communication procedure with a module failed when an instruction was executed. 	<ul style="list-style-type: none"> Review the program and check the contents of the operands used in the applied instructions. Verify that the specified buffer memory exists in the counterpart equipment. Verify that extension cables are correctly connected. 	Error location information and system configuration information	At instruction execution
2500H	WDT error	<ul style="list-style-type: none"> The initial scan time exceeded the set value of execution monitor time. 	<ul style="list-style-type: none"> Recheck the set value of execution monitor time or program. 	Time information	Always
2501H	WDT error	<ul style="list-style-type: none"> The scan time of the second and subsequent scans exceeded the set value of execution monitor time. 	<ul style="list-style-type: none"> Recheck the set value of execution monitor time or program. 	Time information	Always
2522H	Invalid interrupt	<ul style="list-style-type: none"> An interrupt request was detected from a module that does not have an interrupt pointer specified in the parameters. 	<ul style="list-style-type: none"> Correctly set the interrupt pointer for module interrupt. 	System configuration information	At interrupt occurrence
2801H	Module specification error	<ul style="list-style-type: none"> Verify that the module with the specified module number exists. 	<ul style="list-style-type: none"> Specify the correct module number. 	Error location information and system configuration information	At instruction execution
2820H	Device specification error	<ul style="list-style-type: none"> A device used as an instruction operand is outside the allowable device range. 	<ul style="list-style-type: none"> Check the device range and modify the program. 	Error location information	At power-on, at RESET, at instruction execution
2821H	Device specification error	<ul style="list-style-type: none"> There are duplicate devices used as an instruction operand. 	<ul style="list-style-type: none"> Check the range of devices used by each operand and modify the program. 	Error location information	At instruction execution
2822H	Device specification error	<ul style="list-style-type: none"> A device or modification that cannot be used as an instruction operand is used. 	<ul style="list-style-type: none"> Check the usage of the instruction and modify the program. 	Error location information	At power-on, at RESET

Error code	Error name	Error details and cause	Action	Detailed information	Diagnostic timing
2823H	Device specification error	<ul style="list-style-type: none"> Verify that the specified module has buffer memory. Check the buffer memory range of the specified module. Verify that the size specified from the specified buffer memory number is within the buffer memory range. 	<ul style="list-style-type: none"> Review the program or check the contents of the operands used in applied instructions. Verify that the specified buffer memory exists in the counterpart equipment. 	Error location information	At instruction execution
2840H	File name specification error	<ul style="list-style-type: none"> The program file specified does not exist. 	<ul style="list-style-type: none"> Rewrite the project. 	Error location information	At power-on, at RESET
3000H	Boot function execution error	<ul style="list-style-type: none"> An error was found in the boot file. 	<ul style="list-style-type: none"> Replace the boot file in the SD memory card with the correct file and turn the PLC power ON again. 	Drive/file information	At power-on, at RESET
3001H	Boot function execution error	<ul style="list-style-type: none"> Formatting failed during booting. 	<ul style="list-style-type: none"> Reset the CPU module, and then execute the boot function again. If the same error appears, the hardware of the CPU module may be malfunctioning. Consult your local Mitsubishi Electric representative. 	Drive/file information	At power-on, at RESET
3003H	Boot function execution error	<ul style="list-style-type: none"> A mismatch between the file password 32 of the boot source file and that of the boot destination file was detected during booting. 	<ul style="list-style-type: none"> Check the file password 32 of the boot source file. 	Drive/file information	At power-on, at RESET
3004H	Boot function execution error	<ul style="list-style-type: none"> The capacity of the boot destination data memory becomes insufficient due to booting. 	<ul style="list-style-type: none"> Allow sufficient capacity on the boot destination or recheck the file size of the boot source. 	Drive/file information	At power-on, at RESET
3005H	Boot function execution error	<ul style="list-style-type: none"> A mismatch between the security information of the boot source file and that of the boot destination file was detected during booting. 	<ul style="list-style-type: none"> Check the security information of the boot source file. 	Drive/file information	At power-on, at RESET
3048H	Online change error	<ul style="list-style-type: none"> An error was detected when writing was executed during RUN. 	<ul style="list-style-type: none"> Set the CPU module to STOP and write a set of project data. 	—	At END instruction execution
3049H	Online change error	<ul style="list-style-type: none"> An error was detected when writing was executed during RUN. 	<ul style="list-style-type: none"> Set the CPU module to STOP and write a set of project data. 	—	At END instruction execution
304AH	Online change error	<ul style="list-style-type: none"> An error was detected when writing was executed during RUN. 	<ul style="list-style-type: none"> Set the CPU module to STOP and write a set of project data. 	—	At END instruction execution
304BH	Online change error	<ul style="list-style-type: none"> An error was detected when writing was executed during RUN. 	<ul style="list-style-type: none"> Set the CPU module to STOP and write a set of project data. 	—	At END instruction execution
3050H	System bus error	<ul style="list-style-type: none"> Communication with the module failed due to power discontinuity or the like. 	<ul style="list-style-type: none"> Verify that the connected module is powered on. Verify that extension cables are correctly connected. Verify that the version of the CPU module is compatible with the module where the error was detected. Implement anti-noise measures. If there is no problem, there may be a malfunction in the connected module or in the extension cables. 	System configuration information	At power-on, at RESET
3056H	System bus error	<ul style="list-style-type: none"> A timeout occurred during communication with a connected module when an instruction was executed. 	<ul style="list-style-type: none"> Verify that extension cables are correctly connected. Verify that the version of the CPU module is compatible with the module where the error was detected. Implement anti-noise measures. If there is no problem, there may be a malfunction in the connected module or in the extension cables. 	Error location information and system configuration information	At instruction execution

Error code	Error name	Error details and cause	Action	Detailed information	Diagnostic timing
3057H	System bus error	<ul style="list-style-type: none"> A timeout occurred during communication with a connected module when an instruction was executed. 	<ul style="list-style-type: none"> Verify that extension cables are correctly connected. Verify that the version of the CPU module is compatible with the module where the error was detected. Implement anti-noise measures. If there is no problem, there may be a malfunction in the connected module or in the extension cables. 	System configuration information	At END instruction execution, at interrupt occurrence, at module access
3060H	System bus error	<ul style="list-style-type: none"> A signal error was detected while accessing a connected module when an instruction was executed. 	<ul style="list-style-type: none"> Verify that extension cables are correctly connected. Verify that the version of the CPU module is compatible with the module where the error was detected. Implement anti-noise measures. If there is no problem, there may be a malfunction in the connected module or in the extension cables. 	Error location information	At instruction execution
3061H	System bus error	<ul style="list-style-type: none"> A signal error was detected during system processing. 	<ul style="list-style-type: none"> Verify that extension cables are correctly connected. Verify that the version of the CPU module is compatible with the module where the error was detected. Implement anti-noise measures. If there is no problem, there may be a malfunction in the connected module or in the extension cables. 	System configuration information	At instruction execution
3142H	Program structure error	<ul style="list-style-type: none"> The temporary area was used incorrectly. 	<ul style="list-style-type: none"> Check the detailed information (error location information) of the error by executing module diagnostics using the engineering tool, display the error program (step) by clicking the [Error Jump] button, and check the program. The step number displayed in the error location information is counted from the top of the file. (It may be different from the step number in the program displayed by the jump function.) 	Error location information	At instruction execution
3200H	Program execution error	<ul style="list-style-type: none"> The device/label assignment does not match the device/label assignment in the program. (After the device assignment was changed, only the parameters were written to the CPU module.) 	<ul style="list-style-type: none"> If the index modification setting of the PLC parameter is changed, write the parameter and program file to the CPU module at the same time. 	Drive/file information	At power-on, at RESET
3202H	Program execution error	<ul style="list-style-type: none"> The program file is invalid or the file does not contain a program. 	<ul style="list-style-type: none"> Write the correct program file. 	Drive/file information	At power-on, at RESET
3203H	Program execution error	<ul style="list-style-type: none"> No program file exists. 	<ul style="list-style-type: none"> Write a program file. 	Drive/file information	At power-on, at RESET
3210H	Program execution error	<ul style="list-style-type: none"> A program with more than 64 k steps was written. 	<ul style="list-style-type: none"> Reduce the number of steps in the program. 	—	At power-on, at RESET
3211H	Program execution error	<ul style="list-style-type: none"> An FB program larger than the internal memory capacity was written. 	<ul style="list-style-type: none"> Reduce the number of steps in the FB program. 	—	At power-on, at RESET
3212H	Program execution error	<ul style="list-style-type: none"> No program setting is found in the parameters. 	<ul style="list-style-type: none"> Specify the program to execute in the parameters. 	—	At power-on, at RESET
3213H	Program execution error	<ul style="list-style-type: none"> The parameter set value is out of range. 	<ul style="list-style-type: none"> To use this parameter, a new version of the CPU module is required. Replace the CPU module or perform version upgrade. 	Parameter information	At power-on, at RESET
3302H	Pointer setting error	<ul style="list-style-type: none"> Duplicate pointers are programmed. 	<ul style="list-style-type: none"> Modify the program to not use duplicate pointers in a program. 	Error location information	At power-on, at RESET
3320H	Interrupt pointer setting error	<ul style="list-style-type: none"> Duplicate interrupt pointers are programmed. 	<ul style="list-style-type: none"> Modify the program to not use duplicate interrupt pointers in a program. 	Error location information	At power-on, at RESET
3340H	FOR-NEXT instruction error	<ul style="list-style-type: none"> The relationship between FOR and NEXT instructions is invalid. 	<ul style="list-style-type: none"> Make sure that FOR and NEXT instructions are each executed the same number of times. In addition, check the FOR syntax for any invalid jump instructions. 	Error location information	At END instruction execution

Error code	Error name	Error details and cause	Action	Detailed information	Diagnostic timing
3341H	FOR-NEXT instruction error	• The relationship between FOR and NEXT instructions is invalid.	• Make sure that FOR and NEXT instructions are each executed the same number of times. In addition, check syntax for any invalid jump instructions.	Error location information	At END instruction execution
3342H	FOR-NEXT instruction error	• A BREAK instruction was executed outside the FOR syntax.	• The BREAK instruction must be executed inside the FOR syntax.	Error location information	At instruction execution
3360H	Nesting depth error	• The number of nesting levels of subroutine calls is invalid.	• Make sure that the number of nesting levels is 16 or lower. In addition, check subroutine programs for any invalid jump instructions.	Error location information	At instruction execution
3361H	Nesting depth error	• The number of nesting levels of FOR instructions is invalid.	• Make sure that the number of nesting levels is 16 or lower. In addition, check the FOR syntax for any invalid jump instructions.	Error location information	At instruction execution
3362H	Nesting depth error	• The number of nesting levels of DI instructions is invalid.	• Make sure that the number of nesting levels is 16 or lower. In addition, check the relationship between DI and EI instructions.	Error location information	At instruction execution
3380H	Pointer execution error	• There is no pointer to the jump destination.	• Specify the correct jump destination in the program.	Error location information	At instruction execution
3381H	Pointer execution error	• There is an END, FEND, GOEND, or STOP instruction in a subroutine program.	• The END, FEND, GOEND, and STOP instructions can be executed only in the main routine program.	Error location information	At END instruction execution
3382H	Pointer execution error	• A RET instruction was executed without a CALL or XCALL instruction executed.	• Check where there is any invalid jump to subroutine programs.	Error location information	At instruction execution
33D0H	Temporary area exceeded	• The temporary area was used incorrectly.	• Check the detailed information (error location information) of the error by executing module diagnostics using the engineering tool, display the error program (step) by clicking the [Error Jump] button, and check the program. The step number displayed in the error location information is counted from the top of the file. (It may be different from the step number in the program displayed by the jump function.)	Error location information	At instruction execution
33E0H	Program structure error	• The relationship between LD/LDI/LDP/LDF/LDPI/LDFI and ANB/ORB instructions is invalid.	• Rewrite the program file.	Error location information	At power-on, at RESET
33E1H	Program structure error	• The relationship among MPS, MRD, and MPP is invalid.	• Rewrite the program file.	Error location information	At power-on, at RESET
33E2H	Program structure error	• An instruction that should start from the bus line is not connected to the bus line.	• Rewrite the program file.	Error location information	At power-on, at RESET
33E3H	Program structure error	• The relationship between FOR and NEXT instructions is invalid.	• Modify the program so that the mutual relationship between instructions becomes correct.	Error location information	At power-on, at RESET
33E4H	Program structure error	• The relationship between MC and MCR instructions is invalid.	• Modify the program so that the mutual relationship between instructions becomes correct.	Error location information	At power-on, at RESET
33E5H	Program structure error	• The relationship between STL and RETSTL instructions is invalid.	• Modify the program so that the mutual relationship between instructions becomes correct.	Error location information	At power-on, at RESET
33E6H	Program structure error	• An instruction or interrupt pointer that cannot be used in the main routine program is used.	• Modify the program so that instruction or pointer use becomes correct.	Error location information	At power-on, at RESET
33E7H	Program structure error	• The relationship among a global pointer, interrupt pointer, and return instruction is invalid.	• Modify the program so that the mutual relationship between pointer and return instruction becomes correct.	Error location information	At power-on, at RESET
33F1H	Program structure error	• The program structure of the ST language, FB, and functions is invalid.	• Check the syntax of the ST language, FB, and functions.	Error location information	At END instruction execution, at interrupt occurrence
33F2H	Program structure error	• The program structure of the ST language, FB, and functions is invalid.	• Check the syntax of the ST language, FB, and functions.	Error location information	At instruction execution

Error code	Error name	Error details and cause	Action	Detailed information	Diagnostic timing
33F3H	Program structure error	• More than two STL instructions for the same S number are programmed.	• Recheck the structure of the step ladder.	Error location information	At power-on, at RESET, at STOP → RUN state
3400H	Operation error	• A value of 0 was input as a divisor in an applied instruction.	• Review the data specified as the divisor in the applied instruction.	Error location information	At instruction execution
3401H	Operation error	• Data that cannot be converted was input in an applied instruction.	• Review the data specified in the applied instruction.	Error location information	At instruction execution
3402H	Operation error	• A value of -0, a denormalized number, a non-number, or $\pm\infty$ was input in an applied instruction.	• Review the data specified in the applied instruction.	Error location information	At instruction execution
3403H	Operation error	• An overflow occurred in an applied instruction.	• Review the data specified in the applied instruction.	Error location information	At instruction execution
3405H	Operation error	• Data that is outside the allowable range was input in an applied instruction.	• Review the data specified in the applied instruction.	Error location information	At instruction execution
3406H	Operation error	• The output result is outside the allowable device range in an applied instruction.	• Review the data specified in the applied instruction.	Error location information	At instruction execution
3420H	Operation error	• A module access device is specified to both (s) and (d) in a BMOV instruction.	• Review the device specified in the BMOV instruction.	Error location information	At instruction execution
3500H	Operation error	• A value outside the allowable range was set to the sampling time (TS).	• Check the contents of the parameters.	Error location information	At instruction execution
3502H	Operation error	• A value outside the allowable range was set to the input filter constant (α).	• Check the contents of the parameters.	Error location information	At instruction execution
3503H	Operation error	• A value outside the allowable range was set to the proportional gain (KP).	• Check the contents of the parameters.	Error location information	At instruction execution
3504H	Operation error	• A value outside the allowable range was set to the integral time (TI).	• Check the contents of the parameters.	Error location information	At instruction execution
3505H	Operation error	• A value outside the allowable range was set to the derivative gain (KD).	• Check the contents of the parameters.	Error location information	At instruction execution
3506H	Operation error	• A value outside the allowable range was set to the derivative time (TD).	• Check the contents of the parameters.	Error location information	At instruction execution
350AH	Operation error	• The sampling time is lower than the scan time.	• The operation is continued in the condition "sampling time (TS) = cyclic time (scan time)".	Error location information	At instruction execution
350CH	Operation error	• The variation of measured value is greater than the maximum value or lower than the minimum value.	• The operation is continued with the maximum or minimum value.	Error location information	At instruction execution
350DH	Operation error	• The deviation is greater than the maximum value or lower than the minimum value.	• The operation is continued with the maximum or minimum value.	Error location information	At instruction execution
350EH	Operation error	• The integral result is greater than the maximum value or lower than the minimum value.	• The operation is continued with the maximum or minimum value.	Error location information	At instruction execution
350FH	Operation error	• The derivative value is greater than the maximum value or lower than the minimum value due to the derivative gain (KP).	• The operation is continued with the maximum or minimum value.	Error location information	At instruction execution
3510H	Operation error	• The derivative result is greater than the maximum value or lower than the minimum value.	• The operation is continued with the maximum or minimum value.	Error location information	At instruction execution
3511H	Operation error	• The PID operation result is greater than the maximum value or lower than the minimum value.	• The operation is continued with the maximum or minimum value.	Error location information	At instruction execution
3512H	Operation error	• The output upper limit value is lower than the output lower limit value.	• Calculation is continued with the output upper limit value and output lower limit value transposed.	Error location information	At instruction execution
3513H	Operation error	• The input variation alarm set value or output variation alarm set value is outside the allowable range.	• The operation is continued without alarm output.	Error location information	At instruction execution

Error code	Error name	Error details and cause	Action	Detailed information	Diagnostic timing
3514H	Operation error	<ul style="list-style-type: none"> The auto tuning result in the step response method is abnormal. The deviation at start of auto tuning is 150 or less. The deviation at end of auto tuning is 1/3 or more of the deviation at start of auto tuning. 	<ul style="list-style-type: none"> Check the measured value and target value, and then execute auto tuning again. 	Error location information	At instruction execution
3515H	Operation error	<ul style="list-style-type: none"> The operation direction estimated from the measured value at the start of auto tuning in the step response method was different from the actual operation direction of the output during auto tuning. 	<ul style="list-style-type: none"> Correct the relationship among the target value, output value for auto tuning, and the measured value, and then execute auto tuning again. 	Error location information	At instruction execution
3516H	Operation error	<ul style="list-style-type: none"> Because the set value fluctuated during auto tuning in the step response method, auto tuning was not executed correctly. 	<ul style="list-style-type: none"> Set the sampling time to a value larger than the output change cycle, or set a larger value for the input filter constant. After changing the setting, execute auto tuning again. 	Error location information	At instruction execution
3517H	Operation error	<ul style="list-style-type: none"> The output set value upper limit for auto tuning is lower than the lower limit. 	<ul style="list-style-type: none"> Verify that the target setting contents are correct. 	Error location information	At instruction execution
3518H	Operation error	<ul style="list-style-type: none"> A value outside the allowable range was set to the PV threshold for auto tuning. 	<ul style="list-style-type: none"> Verify that the target setting contents are correct. 	Error location information	At instruction execution
3519H	Operation error	<ul style="list-style-type: none"> Operation is not performed normally because devices occupied by the PID instruction were overwritten. 	<ul style="list-style-type: none"> Ensure that devices occupied by PID instruction are not overwritten in the program. 	Error location information	At instruction execution
351AH	Operation error	<ul style="list-style-type: none"> The auto tuning time is longer than necessary. 	<ul style="list-style-type: none"> Increase the difference (ULV - LLV) between the upper limit and lower limit of the output value for auto tuning, set a smaller value to the input filter constant (α), or set a smaller value to the PV threshold (SHPV) for auto tuning, and then check the result for improvement. 	Error location information	At instruction execution
350BH	Operation error	<ul style="list-style-type: none"> The variation of the measured value is too small compared with the output value. 	<ul style="list-style-type: none"> Multiply the measured value (PV) by "10" so that the variation of the measured value will increase during auto tuning. The operation is continued with KP = 32767. 	Error location information	At instruction execution
350CH	Operation error	<ul style="list-style-type: none"> The auto tuning time is longer than necessary. 	<ul style="list-style-type: none"> Increase the difference (ULV - LLV) between the upper limit and lower limit of the output value for auto tuning, set a smaller value to the input filter constant (α), or set a smaller value to the PV threshold (SHPV) for auto tuning, and then check the result for improvement. The operation is continued with KP = 32767. 	Error location information	At instruction execution
350DH	Operation error	<ul style="list-style-type: none"> The auto tuning time is longer than necessary. 	<ul style="list-style-type: none"> Increase the difference (ULV - LLV) between the upper limit and lower limit of the output value for auto tuning, set a smaller value to the input filter constant (α), or set a smaller value to the PV threshold (SHPV) for auto tuning, and then check the result for improvement. The operation is continued with KP = 32767. 	Error location information	At instruction execution
3580H	Operation error	<ul style="list-style-type: none"> An instruction that cannot be used in an interrupt routine program is used. 	<ul style="list-style-type: none"> Modify the program so that no instruction whose use is disabled by the interrupt routine program is used. 	Error location information	At instruction execution
3581H	Operation error	<ul style="list-style-type: none"> Modules subsequent to the bus conversion module are using an operand that cannot be used. 	<ul style="list-style-type: none"> Modify the program so that no operand whose use is disabled for modules subsequent to the bus conversion module is used. 	Error location information	At instruction execution
3582H	Operation error	<ul style="list-style-type: none"> An instruction that cannot be used in an interrupt routine program is used. 	<ul style="list-style-type: none"> Modify the program so that no instruction whose use is disabled by the interrupt routine program is used. 	Error location information	At instruction execution
3600H	Operation error	<ul style="list-style-type: none"> The channel specified by instructions using communication functions or built-in I/O does not have the appropriate parameter. 	<ul style="list-style-type: none"> Verify that the parameter setting of the channel specified by instructions using communication functions or built-in I/O is correct. 	Error location information	At instruction execution

Error code	Error name	Error details and cause	Action	Detailed information	Diagnostic timing
3611H	CH1 pulse width, period setting error	<ul style="list-style-type: none"> The value of the special register to set the pulse width and cycle of the PWM instruction is abnormal. 	<ul style="list-style-type: none"> Modify the value of the special register and restart PWM. 	Error location information and system configuration information	At END instruction execution
3612H	CH2 pulse width, period setting error	<ul style="list-style-type: none"> The value of the special register to set the pulse width and cycle of the PWM instruction is abnormal. 	<ul style="list-style-type: none"> Modify the value of the special register and restart PWM. 	Error location information and system configuration information	At END instruction execution
3613H	CH3 pulse width, period setting error	<ul style="list-style-type: none"> The value of the special register to set the pulse width and cycle of the PWM instruction is abnormal. 	<ul style="list-style-type: none"> Modify the value of the special register and restart PWM. 	Error location information and system configuration information	At END instruction execution
3614H	CH4 pulse width, period setting error	<ul style="list-style-type: none"> The value of the special register to set the pulse width and cycle of the PWM instruction is abnormal. 	<ul style="list-style-type: none"> Modify the value of the special register and restart PWM. 	Error location information and system configuration information	At END instruction execution
3621H	Axis 1 limit detection error	<ul style="list-style-type: none"> Both the forward and reverse limits were detected at the time of zero return or the limit of the moving direction was detected after the near-point dog was detected. 	<ul style="list-style-type: none"> Recheck the relationship between the near-point dog and limits. 	Error location information and system configuration information	At END instruction execution, at instruction execution
3622H	Axis 2 limit detection error	<ul style="list-style-type: none"> Both the forward and reverse limits were detected at the time of zero return or the limit of the moving direction was detected after the near-point dog was detected. 	<ul style="list-style-type: none"> Recheck the relationship between the near-point dog and limits. 	Error location information and system configuration information	At END instruction execution, at instruction execution
3623H	Axis 3 limit detection error	<ul style="list-style-type: none"> Both the forward and reverse limits were detected at the time of zero return or the limit of the moving direction was detected after the near-point dog was detected. 	<ul style="list-style-type: none"> Recheck the relationship between the near-point dog and limits. 	Error location information and system configuration information	At END instruction execution, at instruction execution
3624H	Axis 4 limit detection error	<ul style="list-style-type: none"> Both the forward and reverse limits were detected at the time of zero return or the limit of the moving direction was detected after the near-point dog was detected. 	<ul style="list-style-type: none"> Recheck the relationship between the near-point dog and limits. 	Error location information and system configuration information	At END instruction execution, at instruction execution
3631H	Axis 1 positioning address error	<ul style="list-style-type: none"> The 32-bit range was exceeded when the unit of the positioning address was converted. The total transfer distance before and after the interrupt of the DVIT instruction or 1-speed positioning with interruption exceeded 7FFFFFFFH. Pulses of 7FFFFFFFH or greater are needed to specify an absolute address. 	<ul style="list-style-type: none"> Start the positioning within specifications. 	Error location information and system configuration information	At END instruction execution, at interrupt occurrence
3632H	Axis 2 positioning address error	<ul style="list-style-type: none"> The 32-bit range was exceeded when the unit of the positioning address was converted. The total transfer distance before and after the interrupt of the DVIT instruction or 1-speed positioning with interruption exceeded 7FFFFFFFH. Pulses of 7FFFFFFFH or greater are needed to specify an absolute address. 	<ul style="list-style-type: none"> Start the positioning within specifications. 	Error location information and system configuration information	At END instruction execution, at interrupt occurrence
3633H	Axis 3 positioning address error	<ul style="list-style-type: none"> The 32-bit range was exceeded when the unit of the positioning address was converted. The total transfer distance before and after the interrupt of the DVIT instruction or 1-speed positioning with interruption exceeded 7FFFFFFFH. Pulses of 7FFFFFFFH or greater are needed to specify an absolute address. 	<ul style="list-style-type: none"> Start the positioning within specifications. 	Error location information and system configuration information	At END instruction execution, at interrupt occurrence

Error code	Error name	Error details and cause	Action	Detailed information	Diagnostic timing
3634H	Axis 4 positioning address error	<ul style="list-style-type: none"> The 32-bit range was exceeded when the unit of the positioning address was converted. The total transfer distance before and after the interrupt of the DVIT instruction or 1-speed positioning with interruption exceeded 7FFFFFFH. Pulses of 7FFFFFFH or greater are needed to specify an absolute address. 	<ul style="list-style-type: none"> Start the positioning within specifications. 	Error location information and system configuration information	At END instruction execution, at interrupt occurrence
3641H	Axis 1 command speed error	<ul style="list-style-type: none"> The 32-bit range was exceeded when the unit of the command speed was converted. 	<ul style="list-style-type: none"> Start the positioning within specifications. 	Error location information and system configuration information	At instruction execution
3642H	Axis 2 command speed error	<ul style="list-style-type: none"> The 32-bit range was exceeded when the unit of the command speed was converted. 	<ul style="list-style-type: none"> Start the positioning within specifications. 	Error location information and system configuration information	At instruction execution
3643H	Axis 3 command speed error	<ul style="list-style-type: none"> The 32-bit range was exceeded when the unit of the command speed was converted. 	<ul style="list-style-type: none"> Start the positioning within specifications. 	Error location information and system configuration information	At instruction execution
3644H	Axis 4 command speed error	<ul style="list-style-type: none"> The 32-bit range was exceeded when the unit of the command speed was converted. 	<ul style="list-style-type: none"> Start the positioning within specifications. 	Error location information and system configuration information	At instruction execution
3651H	Axis 1 error stop (deceleration stop)	<ul style="list-style-type: none"> When pulses were being output or positioning was rising, the PLC decelerated and stopped the pulse output due to the limit of the moving direction or writing during RUN. (The PLSY instruction stops pulse output immediately at both limits.) 	<ul style="list-style-type: none"> Eliminate the error that has caused the stop and restart the positioning. 	Error location information and system configuration information	At END instruction execution, at instruction execution
3652H	Axis 2 error stop (deceleration stop)	<ul style="list-style-type: none"> When pulses were being output or positioning was rising, the PLC decelerated and stopped the pulse output due to the limit of the moving direction or writing during RUN. (The PLSY instruction stops pulse output immediately at both limits.) 	<ul style="list-style-type: none"> Eliminate the error that has caused the stop and restart the positioning. 	Error location information and system configuration information	At END instruction execution, at instruction execution
3653H	Axis 3 error stop (deceleration stop)	<ul style="list-style-type: none"> When pulses were being output or positioning was rising, the PLC decelerated and stopped the pulse output due to the limit of the moving direction or writing during RUN. (The PLSY instruction stops pulse output immediately at both limits.) 	<ul style="list-style-type: none"> Eliminate the error that has caused the stop and restart the positioning. 	Error location information and system configuration information	At END instruction execution, at instruction execution
3654H	Axis 4 error stop (deceleration stop)	<ul style="list-style-type: none"> When pulses were being output or positioning was rising, the PLC decelerated and stopped the pulse output due to the limit of the moving direction or writing during RUN. (The PLSY instruction stops pulse output immediately at both limits.) 	<ul style="list-style-type: none"> Eliminate the error that has caused the stop and restart the positioning. 	Error location information and system configuration information	At END instruction execution, at instruction execution
3661H	Axis 1 error stop (immediately stop)	<ul style="list-style-type: none"> When pulses were being output or positioning was rising, the PLC stopped the pulse output immediately by the pulse stop command or detection of the all outputs disable flag. 	<ul style="list-style-type: none"> Eliminate the error that has caused the stop and restart the positioning. 	Error location information and system configuration information	At END instruction execution, at instruction execution
3662H	Axis 2 error stop (immediately stop)	<ul style="list-style-type: none"> When pulses were being output or positioning was rising, the PLC stopped the pulse output immediately by the pulse stop command or detection of the all outputs disable flag. 	<ul style="list-style-type: none"> Eliminate the error that has caused the stop and restart the positioning. 	Error location information and system configuration information	At END instruction execution, at instruction execution

Error code	Error name	Error details and cause	Action	Detailed information	Diagnostic timing
3663H	Axis 3 error stop (immediately stop)	<ul style="list-style-type: none"> When pulses were being output or positioning was rising, the PLC stopped the pulse output immediately by the pulse stop command or detection of the all outputs disable flag. 	<ul style="list-style-type: none"> Eliminate the error that has caused the stop and restart the positioning. 	Error location information and system configuration information	At END instruction execution, at instruction execution
3664H	Axis 4 error stop (immediately stop)	<ul style="list-style-type: none"> When pulses were being output or positioning was rising, the PLC stopped the pulse output immediately by the pulse stop command or detection of the all outputs disable flag. 	<ul style="list-style-type: none"> Eliminate the error that has caused the stop and restart the positioning. 	Error location information and system configuration information	At END instruction execution, at instruction execution
3671H	Axis 1 positioning table operand error	<ul style="list-style-type: none"> The value of an operand in the table is abnormal. (Other than the positioning address and command speed) 	<ul style="list-style-type: none"> Set the correct value to the table. 	Error location information and system configuration information	At END instruction execution, at interrupt occurrence
3672H	Axis 2 positioning table operand error	<ul style="list-style-type: none"> The value of an operand in the table is abnormal. (Other than the positioning address and command speed) 	<ul style="list-style-type: none"> Set the correct value to the table. 	Error location information and system configuration information	At END instruction execution, at interrupt occurrence
3673H	Axis 3 positioning table operand error	<ul style="list-style-type: none"> The value of an operand in the table is abnormal. (Other than the positioning address and command speed) 	<ul style="list-style-type: none"> Set the correct value to the table. 	Error location information and system configuration information	At END instruction execution, at interrupt occurrence
3674H	Axis 4 positioning table operand error	<ul style="list-style-type: none"> The value of an operand in the table is abnormal. (Other than the positioning address and command speed) 	<ul style="list-style-type: none"> Set the correct value to the table. 	Error location information and system configuration information	At END instruction execution, at interrupt occurrence
3681H	Axis 1 positioning table shift error (table specification)	<ul style="list-style-type: none"> Tables which cannot be used together were specified for continuous operation. The counterpart axis for the interpolation operation table was specified. 	<ul style="list-style-type: none"> Observe the restrictions on table operation. 	Error location information and system configuration information	At END instruction execution, at interrupt occurrence
3682H	Axis 2 positioning table shift error (table specification)	<ul style="list-style-type: none"> Tables which cannot be used together were specified for continuous operation. The counterpart axis for the interpolation operation table was specified. 	<ul style="list-style-type: none"> Observe the restrictions on table operation. 	Error location information and system configuration information	At END instruction execution, at interrupt occurrence
3683H	Axis 3 positioning table shift error (table specification)	<ul style="list-style-type: none"> Tables which cannot be used together were specified for continuous operation. The counterpart axis for the interpolation operation table was specified. 	<ul style="list-style-type: none"> Observe the restrictions on table operation. 	Error location information and system configuration information	At END instruction execution, at interrupt occurrence
3684H	Axis 4 positioning table shift error (table specification)	<ul style="list-style-type: none"> Tables which cannot be used together were specified for continuous operation. The counterpart axis for the interpolation operation table was specified. 	<ul style="list-style-type: none"> Observe the restrictions on table operation. 	Error location information and system configuration information	At END instruction execution, at interrupt occurrence
3691H	Axis 1 positioning table shift error (table shift)	<ul style="list-style-type: none"> Table shift cannot be completed in time because one or more tables shifted per 10 ms. 	<ul style="list-style-type: none"> Set the interval of table shifts to 10 ms or greater. 	Error location information and system configuration information	At interrupt occurrence
3692H	Axis 2 positioning table shift error (table shift)	<ul style="list-style-type: none"> Table shift cannot be completed in time because one or more tables shifted per 10 ms. 	<ul style="list-style-type: none"> Set the interval of table shifts to 10 ms or greater. 	Error location information and system configuration information	At interrupt occurrence
3693H	Axis 3 positioning table shift error (table shift)	<ul style="list-style-type: none"> Table shift cannot be completed in time because one or more tables shifted per 10 ms. 	<ul style="list-style-type: none"> Set the interval of table shifts to 10 ms or greater. 	Error location information and system configuration information	At interrupt occurrence

Error code	Error name	Error details and cause	Action	Detailed information	Diagnostic timing
3694H	Axis 4 positioning table shift error (table shift)	<ul style="list-style-type: none"> Table shift cannot be completed in time because one or more tables shifted per 10 ms. 	<ul style="list-style-type: none"> Set the interval of table shifts to 10 ms or greater. 	Error location information and system configuration information	At interrupt occurrence
36A1H	Axis 1 interpolation operation error (no counterpart axis)	<ul style="list-style-type: none"> The counterpart axis table for the interpolation operation cannot be found. 	<ul style="list-style-type: none"> Set the table of the counterpart axis correctly. 	Error location information and system configuration information	At instruction execution
36A2H	Axis 2 interpolation operation error (no counterpart axis)	<ul style="list-style-type: none"> The counterpart axis table for the interpolation operation cannot be found. 	<ul style="list-style-type: none"> Set the table of the counterpart axis correctly. 	Error location information and system configuration information	At instruction execution
36A3H	Axis 3 interpolation operation error (no counterpart axis)	<ul style="list-style-type: none"> The counterpart axis table for the interpolation operation cannot be found. 	<ul style="list-style-type: none"> Set the table of the counterpart axis correctly. 	Error location information and system configuration information	At instruction execution
36A4H	Axis 4 interpolation operation error (no counterpart axis)	<ul style="list-style-type: none"> The counterpart axis table for the interpolation operation cannot be found. 	<ul style="list-style-type: none"> Set the table of the counterpart axis correctly. 	Error location information and system configuration information	At instruction execution
36B1H	Axis 1 interpolation operation error (reference/ counterpart axis error)	<ul style="list-style-type: none"> Conditions such as limits were satisfied to stop pulses in the reference axis or counterpart axis. Pulses are being output. 	<ul style="list-style-type: none"> Verify that the reference axis and counterpart axis are not in use and the stop conditions are not satisfied. 	Error location information and system configuration information	At instruction execution
36B2H	Axis 2 interpolation operation error (reference/ counterpart axis error)	<ul style="list-style-type: none"> Conditions such as limits were satisfied to stop pulses in the reference axis or counterpart axis. Pulses are being output. 	<ul style="list-style-type: none"> Verify that the reference axis and counterpart axis are not in use and the stop conditions are not satisfied. 	Error location information and system configuration information	At instruction execution
36B3H	Axis 3 interpolation operation error (reference/ counterpart axis error)	<ul style="list-style-type: none"> Conditions such as limits were satisfied to stop pulses in the reference axis or counterpart axis. Pulses are being output. 	<ul style="list-style-type: none"> Verify that the reference axis and counterpart axis are not in use and the stop conditions are not satisfied. 	Error location information and system configuration information	At instruction execution
36B4H	Axis 4 interpolation operation error (reference/ counterpart axis error)	<ul style="list-style-type: none"> Conditions such as limits were satisfied to stop pulses in the reference axis or counterpart axis. Pulses are being output. 	<ul style="list-style-type: none"> Verify that the reference axis and counterpart axis are not in use and the stop conditions are not satisfied. 	Error location information and system configuration information	At instruction execution
36F0H	ABS sum error	<ul style="list-style-type: none"> There is a sum check error in ABS data read from servo. 	<ul style="list-style-type: none"> Check servo wiring and setting. 	Error location information and system configuration information	At instruction execution
3780H	High-speed comparison table maximum excess error	<ul style="list-style-type: none"> The number of high-speed comparison tables registered is greater than the upper limit. 	<ul style="list-style-type: none"> Check the total number of tables in the parameters and tables registered in the comparison match instruction. 	Error location information	At END instruction execution, at instruction execution
3781H	Preset value range outside error	<ul style="list-style-type: none"> The preset value is greater than the ring length set value. 	<ul style="list-style-type: none"> Disable the ring length. Set the preset value within the ring length range. 	Error location information and system configuration information	At instruction execution

Error code	Error name	Error details and cause	Action	Detailed information	Diagnostic timing
3C00H	Hardware failure	• A hardware failure was detected.	• Reset the CPU module and perform RUN. If the same error appears, the hardware of the CPU module may be malfunctioning. Consult your local Mitsubishi Electric representative.	System configuration information	At power-on, at RESET
3C01H	Hardware failure	• A hardware failure was detected.	• Reset the CPU module and perform RUN. If the same error appears, the hardware of the CPU module may be malfunctioning. Consult your local Mitsubishi Electric representative.	System configuration information	At power-on, at RESET
3C02H	Hardware failure	• A hardware failure was detected.	• Reset the CPU module and perform RUN. If the same error appears, the hardware of the CPU module may be malfunctioning. Consult your local Mitsubishi Electric representative.	System configuration information	At power-on, at RESET
3C03H	Hardware failure	• A hardware failure was detected.	• Reset the CPU module and perform RUN. If the same error appears, the hardware of the CPU module may be malfunctioning. Consult your local Mitsubishi Electric representative.	—	At power-on, at RESET
3C0FH	Hardware failure	• A hardware failure was detected.	• Reset the CPU module and perform RUN. If the same error appears, the hardware of the CPU module may be malfunctioning. Consult your local Mitsubishi Electric representative.	—	At power-on, at RESET
3C20H	Memory error	• A memory error was detected.	• Reset the CPU module and perform RUN. If the same error appears, the hardware of the CPU module may be malfunctioning. Consult your local Mitsubishi Electric representative.	—	At power-on, at RESET
3C22H	Memory error	• A memory error was detected.	• Reset the CPU module and perform RUN. If the same error appears, the hardware of the CPU module may be malfunctioning. Consult your local Mitsubishi Electric representative.	—	At power-on, at RESET
3C2FH	Memory error	• A memory error was detected.	• Reset the CPU module and perform RUN. If the same error appears, the hardware of the CPU module may be malfunctioning. Consult your local Mitsubishi Electric representative.	—	At power-on, at RESET
3E20H	Program execution error	• A program larger than the internal memory capacity was written.	• Reset the CPU module and perform RUN. If the same error appears, the hardware of the CPU module may be malfunctioning. Consult your local Mitsubishi Electric representative.	—	At memory card attachment or detachment

Error codes of the CPU module (4000H to 4FFFH)

The following table lists the error codes detected by other causes than the self-diagnostics function of the CPU module.

Error code	Error name	Error details and cause	Action
4000H	Common error	<ul style="list-style-type: none"> Serial communication sum check error. 	<ul style="list-style-type: none"> Connect the serial communication cable correctly. Take measures to reduce noise.
4001H	Common error	<ul style="list-style-type: none"> An unsupported request was executed. 	<ul style="list-style-type: none"> Check the command data of SLMP/MC protocol. Check the CPU module model name selected in the engineering tool. Check the target CPU module model name.
4002H	Common error	<ul style="list-style-type: none"> An unsupported request was executed. 	<ul style="list-style-type: none"> Check the command data of SLMP/MC protocol. Check the CPU module model name selected in the engineering tool. Execute the request again. If the same error code is displayed again, the possible cause is a hardware failure of the CPU module. Please consult your local Mitsubishi representative.
4005H	Common error	<ul style="list-style-type: none"> The volume of data handled according to the specified request is too large. 	<ul style="list-style-type: none"> Check the command data of SLMP/MC protocol.
4006H	Common error	<ul style="list-style-type: none"> Initial communication has failed. 	<ul style="list-style-type: none"> When using serial communication, check with the external device manufacturer for support conditions. When using serial communication, check the CPU module model name selected in the engineering tool. When using Ethernet communication, shift the communication start timing.
4010H	CPU module operation error	<ul style="list-style-type: none"> Since the CPU module is running, the request contents cannot be executed. 	<ul style="list-style-type: none"> Execute after setting the CPU module to STOP status.
4013H	CPU module operation error	<ul style="list-style-type: none"> Since the CPU module is not in a STOP status, the request contents cannot be executed. 	<ul style="list-style-type: none"> Execute after setting the CPU module to STOP status.
4021H	File related error	<ul style="list-style-type: none"> The specified drive (memory) does not exist or there is an error. 	<ul style="list-style-type: none"> Check the specified drive (memory) status. Back up data in the CPU module, and then initialize the memory.
4022H	File related error	<ul style="list-style-type: none"> The file with the specified file name or file No. does not exist. 	<ul style="list-style-type: none"> Check the specified file name and file No.
4025H	File related error	<ul style="list-style-type: none"> The specified file is processing the request from another engineering tool. 	<ul style="list-style-type: none"> Forcibly execute the request. Or, execute the request again after the processing being performed ends.
4027H	File related error	<ul style="list-style-type: none"> The specified range is larger than the file size. 	<ul style="list-style-type: none"> Check the specified range and access within that range.
4029H	File related error	<ul style="list-style-type: none"> The specified file capacity cannot be obtained. 	<ul style="list-style-type: none"> Review the specified file capacity, and execute the request again.
402CH	File related error	<ul style="list-style-type: none"> The requested operation cannot be executed currently. 	<ul style="list-style-type: none"> Execute again after a while.
4030H	Device specification error	<ul style="list-style-type: none"> The specified device name cannot be handled. 	<ul style="list-style-type: none"> Check the specified device name.
4031H	Device specification error	<ul style="list-style-type: none"> The specified device No. is outside the range. The CPU module cannot handle the specified device. 	<ul style="list-style-type: none"> Check the specified device No. Check the device assignment of the CPU module. Check the specified device name.
4040H	Intelligent function module specification error	<ul style="list-style-type: none"> The request contents cannot be executed in the specified intelligent function module. 	<ul style="list-style-type: none"> Check whether the specified module is the intelligent function module having the buffer memory.
4041H	Intelligent function module specification error	<ul style="list-style-type: none"> The access range exceeds the buffer memory range of the specified intelligent function module. 	<ul style="list-style-type: none"> Check the start address and access number of points and access within the range that exists in the intelligent function module.
4042H	Intelligent function module specification error	<ul style="list-style-type: none"> The specified intelligent function module cannot be accessed. 	<ul style="list-style-type: none"> Check that the specified intelligent function module is operating normally. Check the specified module for a hardware fault.
4043H	Intelligent function module specification error	<ul style="list-style-type: none"> The intelligent function module does not exist in the specified position. 	<ul style="list-style-type: none"> Check the I/O number of the specified intelligent function module.

Error code	Error name	Error details and cause	Action
4053H	Protect error	<ul style="list-style-type: none"> An error occurred when writing data to the specified drive (memory). 	<ul style="list-style-type: none"> Check the specified drive (memory). Or, write data again after changing the corresponding drive (memory).
4060H	Online registration error	<ul style="list-style-type: none"> The online debug function is being executed with another engineering tool. 	<ul style="list-style-type: none"> Finish the operation of the other engineering tool and then execute the function again. If the operation of the other engineering tool is on hold, resume and finish the operation of the other engineering tool, and then execute the function again.
4080H	Other errors	<ul style="list-style-type: none"> Request data error. 	<ul style="list-style-type: none"> Check the request data that has been specified.
4081H	Other errors	<ul style="list-style-type: none"> The search target data cannot be detected. 	<ul style="list-style-type: none"> Check the data to be searched.
408BH	Other errors	<ul style="list-style-type: none"> The remote request cannot be executed. 	<ul style="list-style-type: none"> Reexecute after the CPU module is in a status where the remote request can be executed. For remote operation, set the parameter to "Enable remote reset".
4121H	File related error	<ul style="list-style-type: none"> The specified drive (memory) or file does not exist. 	<ul style="list-style-type: none"> Execute again after checking the specified drive (memory) or file.
4122H	File related error	<ul style="list-style-type: none"> The specified drive (memory) or file does not exist. 	<ul style="list-style-type: none"> Execute again after checking the specified drive (memory) or file.
4127H	File related error	<ul style="list-style-type: none"> File password 32 mismatch. 	<ul style="list-style-type: none"> Execute again after checking the file password 32.
4135H	File related error	<ul style="list-style-type: none"> The date/time data of the engineering tool (personal computer) is out of range. 	<ul style="list-style-type: none"> Execute again after checking the clock setting of the engineering tool (personal computer).
4139H	File related error	<ul style="list-style-type: none"> The size of the specified file has exceeded that of the existing file. 	<ul style="list-style-type: none"> Execute again after checking the size of the specified file.
413AH	File related error	<ul style="list-style-type: none"> The specified file has exceeded the already existing file size. 	<ul style="list-style-type: none"> Execute again after checking the size of the specified file.
413BH	File related error	<ul style="list-style-type: none"> The same file was simultaneously accessed from different engineering tools. 	<ul style="list-style-type: none"> Execute again after a while.
413EH	File related error	<ul style="list-style-type: none"> Operation is disabled for the specified drive (memory). 	<ul style="list-style-type: none"> Execute again after changing the target drive (memory).
4171H	CPU module built-in Ethernet port error	<ul style="list-style-type: none"> The port for communication use is in remote password locked status. 	<ul style="list-style-type: none"> Execute communication after unlocking the remote password processing.
4181H	CPU module built-in Ethernet port error	<ul style="list-style-type: none"> Transmission to the receiving modules is unsuccessful. 	<ul style="list-style-type: none"> Check the external device operation. Check the status of the lines, such as cables, hubs and routes, connected to receiving modules. Some line packets may be engaged. Retry to communicate a little while later. The receiving module may have no free space in receive area (TCP window size is small). Check whether the receiving module processes receive data, or whether the CPU module does not send unnecessary data. Check whether the settings of the subnet mask pattern and the default router IP address of the CPU module and the receiving modules are correct, or whether the class of the IP address is correct.
4183H	CPU module built-in Ethernet port error	<ul style="list-style-type: none"> Communication with receiving modules was interrupted. 	<ul style="list-style-type: none"> Check the external device operation. Check the status of the lines such as cables, hubs and routes connected to receiving modules. Error may be generated when connection is forcibly canceled during communication. In that case, there is no issue, so clear the error.
419EH	CPU module built-in Ethernet port error	<ul style="list-style-type: none"> Connection to the module was unsuccessful or interrupted. 	<ul style="list-style-type: none"> Check the external device operation. Check the status of the lines such as cables, hubs and routes connected to receiving modules. Retry to connect a little while later, if the error occurred in communication.
41C5H	File related error	<ul style="list-style-type: none"> The specified file does not exist. 	<ul style="list-style-type: none"> Execute again after checking the file.
41C8H	File related error	<ul style="list-style-type: none"> The size of the specified file has exceeded that of the existing file. 	<ul style="list-style-type: none"> Execute again after checking the size of the specified file. If the error recurs after re-execution, the file information data may be corrupted. Back up data in the CPU module, and then initialize the memory.

Error code	Error name	Error details and cause	Action
41D0H	File related error	<ul style="list-style-type: none"> The specified drive (memory) has no free space. Or, the number of files in the directory of the specified drive (memory) has exceeded the maximum. 	<ul style="list-style-type: none"> Execute again after increasing the free space of the drive (memory). Delete files in the drive (memory), and execute the function again.
41D8H	File related error	<ul style="list-style-type: none"> The specified file is being accessed. 	<ul style="list-style-type: none"> Execute again after a while.
41DFH	File related error	<ul style="list-style-type: none"> The specified drive (memory) is write-protected. 	<ul style="list-style-type: none"> Execute again after canceling the write protect of the specified drive (memory).
41EBH	File related error	<ul style="list-style-type: none"> The file name path is too long. 	<ul style="list-style-type: none"> Execute again after shortening the file name path.
41FEH	File related error	<ul style="list-style-type: none"> The SD memory card has not been inserted. The SD memory card is disabled. The SD memory card is disabled by SM606 (SD memory card forced disable instruction). 	<ul style="list-style-type: none"> Insert the SD memory card. Remove the SD memory card, and insert it again. Cancel the SD memory card forced disable instruction.
4401H	Security function error	<ul style="list-style-type: none"> Read password authentication has failed when required. The file password 32 format is incorrect. 	<ul style="list-style-type: none"> Set the correct read password and perform password authentication. Access the file with the correct method.
4402H	Security function error	<ul style="list-style-type: none"> Write password authentication has failed when required. The file password 32 format is incorrect. 	<ul style="list-style-type: none"> Set the correct write password and perform password authentication. Access the file with the correct method.
4403H	Security function error	<ul style="list-style-type: none"> Both passwords for reading and for writing do not match the previous passwords when trying to change, authenticate, or delete password. 	<ul style="list-style-type: none"> Set correct passwords for both reading and writing, and perform password authentication.
4408H	Security function error	<ul style="list-style-type: none"> File password 32 authentication has failed when required. 	<ul style="list-style-type: none"> Set the correct password and perform password authentication again.
440EH	Security function error	<ul style="list-style-type: none"> The security function was activated and password authentication cannot be performed. Register/cancel file password 32 was attempted on a file set to permanent PLC lock. 	<ul style="list-style-type: none"> Set a correct password and perform password authentication again after a certain period of time. It is necessary to delete the whole project to delete the file set to permanent PLC lock.
4412H	Security function error	<ul style="list-style-type: none"> The security key cannot be registered to the CPU module due to failure of the internal memory where the security key is registered. Or, the security key of the CPU module cannot be deleted. 	<ul style="list-style-type: none"> Hardware failure of the CPU module. Replace the CPU module.
4416H	Security function error	<ul style="list-style-type: none"> Since the CPU module is in lock or unlock operation, the requested processing cannot be performed. 	<ul style="list-style-type: none"> Request the processing after the lock or unlock operation ends.
4422H	Security function error	<ul style="list-style-type: none"> The access target CPU module does not support the security key information stored in the engineering tool. 	<ul style="list-style-type: none"> Change the security key information version of the engineering tool in accordance with the version supported by the target CPU module.
4423H	Security function error	<ul style="list-style-type: none"> The specified target of security key operation is inaccurate. 	<ul style="list-style-type: none"> Set target of security key operation to CPU module.
4B00H	Target module error	<ul style="list-style-type: none"> An error occurred in the access destination or relay station. The specified transfer setup (request destination module number) is invalid. 	<ul style="list-style-type: none"> Take corrective action after checking the error that occurred at the specified access destination or the relay station to the accessed station. Check the transfer setup (request destination module number or PLC number) in the request data of SLMP/MC protocol. Check the stop error, and take action.
4B02H	Target module error	<ul style="list-style-type: none"> The request is not addressed to the CPU module. 	<ul style="list-style-type: none"> Perform operation to a module that can execute the specified function.
4B03H	Target module error	<ul style="list-style-type: none"> The specified route is not supported by the specified CPU module version. The communication target CPU module is not mounted. 	<ul style="list-style-type: none"> Check whether the specified route is supported or not. Check the mounting status of the CPU module. Check the stop error, and take action.

Appendix 4 Parameter List

A parameter list is shown below.

System parameters

Classification-Level 1	Classification-Level 2	Classification-Level 3
I/O Assignment Setting	Model Name	—
	Intelligent Module No.	—
	Serial Communication ch	—
	CPU Module Operation at Error Detection	—

CPU parameters

Classification-Level 1	Classification-Level 2	Classification-Level 3
Name Setting	Title Setting	Title
	Comment Setting	Comment
Operation Related Setting	RUN Contact Setting	RUN
		Contact Operation
	Remote Reset Setting	Remote Reset
	Clock Related Setting	Time Zone
Comment		
Interrupt Settings	Fixed Scan Interval Setting	Interrupt Setting from Internal Timer
	Fixed Scan Execution Mode Setting	Fixed Scan Execution Mode
	Interrupt Priority Setting from Module	Multiple Interrupt
		Interrupt Priority
Service Processing Setting	Device/Label Access Service Processing Setting	Specifying Method
		Setting of Device Initial Value Use Or Not
File Setting	Initial Value Setting	Target Memory
		Global Device Initial Value File Name
		Option Battery Setting
Memory/Device Setting	Device/Label Memory Area Setting	Device/Label Memory Area Capacity Setting
		Device/Label Memory Area Detailed Setting
		Points Setting
	Pointer Setting	Total Points
RAS Setting	Scan Time Monitoring Time (WDT) Setting	Initial Scan
		After 2nd Scan
	Constant Scan Setting	Constant Scan
	Error Detections Setting	Battery Error
		Module Verify Error
	CPU Module Operation Setting at Error Detected	Instruction Execution Error
		Memory Card Error
		Module Verify Error
System Configuration Error		
LED Display Setting	ERROR LED	
	BATTERY LED	
Program Setting	Program Setting	Program Setting
	FB/FUN File Setting	FB/FUN File Setting

Module parameters

Ethernet Port

Classification-Level 1	Classification-Level 2	Classification-Level 3
Basic Settings	Own Node Settings	IP Address
	External Device Configuration	External Device Configuration
Application Settings	Security	Disable Direct Connection with MELSOFT
		Do Not Respond to CPU Module Search

485 Serial Port

■MELSOFT Connection

Classification-Level 1	Classification-Level 2	Classification-Level 3
Basic Settings	Communication Protocol Type	Communication Protocol Type

■Non-Protocol Communication

Classification-Level 1	Classification-Level 2	Classification-Level 3
Basic Settings	Communication Protocol Type	Communication Protocol Type
	Advanced Settings	Data Length
		Parity Bit
		Stop Bit
		Baud Rate
		Header
		Header Setting Value
		Terminator
		Terminator Setting Value
		Control Mode (RS-232C)
		Control Mode (RS-485)
		Sum Check Code
		Control Procedure
Fixed Setting	8 bit Process Mode	8 Bit Processing Mode
	Time-out Period	Time-out Period
SM/SD Setting	Latch Setting	Advanced Settings
		8 Bit Process Mode
		Time-out Period
		Header Setting Value
	Terminator Setting Value	
	FX3 Series Compatibility	SM/SD for Compatible

■MC Protocol

Classification-Level 1	Classification-Level 2	Classification-Level 3
Basic Settings	Communication Protocol Type	Communication Protocol Type
	Advanced Settings	Data Length
		Parity Bit
		Stop Bit
		Baud Rate
		Sum Check Code
Fixed Setting	Station Number	Station Number
	Message Pattern	Message Pattern
	Time-out Period	Time-out Period

Classification-Level 1	Classification-Level 2	Classification-Level 3
SM/SD Setting	Latch Setting	Advanced Settings
		Station Number
		Header Setting Value
		Time-out Period
	FX3 Series Compatibility	SM/SD for Compatible

MODBUS_RTU Communication

Classification-Level 1	Classification-Level 2	Classification-Level 3
Basic Settings	Communication Protocol Type	Communication Protocol Type
	Advanced Settings	Parity Bit
		Stop Bit
		Baud Rate
Fixed Setting	Host Station No.	Host Station No.
	Slave Response Timeout	Slave Response Timeout
	Broadcast Delay	Broadcast Delay
	Message to Message Delay	Message to Message Delay
	Timeout Retry Count Setting	Timeout Retry Count Setting
Modbus Device Assigned	Modbus Device Assigned	Device Assigned
SM/SD Setting	Latch Setting	Advanced Settings
		Host Station No.
		Slave Response Timeout
		Broadcast Delay
		Message to Message Delay
		Timeout Retry Count Setting
	FX3 Series Compatibility	SM/SD for Compatible

Predefined Protocol Support Function

Classification-Level 1	Classification-Level 2	Classification-Level 3
Basic Settings	Communication Protocol Type	Communication Protocol Type
	Advanced Settings	Data Length
		Parity Bit
		Stop Bit
		Baud Rate

Inverter Communication

Classification-Level 1	Classification-Level 2	Classification-Level 3
Basic Settings	Communication Protocol Type	Communication Protocol Type
	Advanced Settings	Data Length
		Parity Bit
		Stop Bit
		Baud Rate
Fixed Setting	Response Waiting Time	Response Waiting Time
SM/SD Setting	Latch Setting	Advanced Settings
		Response Waiting Time
	FX3 Series Compatibility	SM/SD for Compatible

N:N Network

Classification-Level 1	Classification-Level 2	Classification-Level 3
Basic Settings	Communication Protocol Type	Communication Protocol Type
Fixed Setting	Host Station No.	Host Station No.
	Total Number of Local Station	Total Number of Local Station
	Refresh Range	Refresh Range
	Timeout Retry Count Setting	Timeout Retry Count Setting
	Monitoring Time	Monitoring Time

Classification-Level 1	Classification-Level 2	Classification-Level 3
Link Device	Pattern	Pattern
	Link Device Bit	Device
	Link Device Word	Device
SM/SD Setting	Latch Setting	Host Station No.
		Total Number of Local Station
		Refresh Range
		Timeout Retry Count Setting
	Monitoring Time	
	FX3 Series Compatibility	SM/SD for Compatible

High Speed I/O Settings

Classification-Level 1	Classification-Level 2	Classification-Level 3
Input Function	General/Interrupt/Pulse catch	General/Interrupt/Pulse catch
	High Speed Counter	High Speed Counter
	Pulse Width Measurement	Pulse Width Measurement
Output Function	Positioning	Positioning
	PWM	PWM
Input Check	Input Response Time	Input Response Time
	Input Interrupt	Rising
		Falling
		Rising+Falling
	Pulse Catch	Pulse Catch
	High Speed Counter	CH1 to 8
	Pulse Width Measurement	CH1 to 4
	Positioning	External Start Signal Positive Logic (Axis 1 to 4)
		External Start Signal Negative Logic (Axis 1 to 4)
		Interrupt Input Signal 1 High Speed (Axis 1 to 4)
		Interrupt Input Signal 1 Standard Positive Logic (Axis 1 to 4)
		Interrupt Input Signal 1 Standard Negative Logic (Axis 1 to 4)
		Near-point Dog Signal (Axis 1 to 4)
Zero Signal Positive Logic (Axis 1 to 4)		
Zero Signal Negative Logic (Axis 1 to 4)		
Interrupt Input Signal 2 (Axis 1 to 4)		
Output Confirmation	Positioning	Pulse Output (PULSE) (Axis 1 to 4)
		Pulse Output (SIGN) (Axis 1 to 4)
		Pulse Output (CW) (Axis 1 to 4)
		Pulse Output (CCW) (Axis 1 to 4)
		Clear Signal (Axis 1 to 4)
	PWM	CH1 to 4

■ General/Interrupt/Pulse catch

Classification-Level 1	Classification-Level 2	Classification-Level 3
General/Interrupt/Pulse Catch	General/Interrupt/Pulse Catch Setting	X0 to X17

High Speed Counter

Classification-Level 1	Classification-Level 2	Classification-Level 3	
Basic Settings	Use/Do Not Use Counter	Use/Not Use	
	Operation Mode	Operation Mode	
	Pulse Input Mode	Pulse Input Mode	
	Preset Input		Preset Input Enable/Disable
			Input Logic
			Preset Value
			Input Comparison Enable/Disable
	Enable Input		Enable Input Enable/Disable
			Input logic
	Ring Length Setting		Ring Length Enable/Disable
Ring Length			
Measurement Unit Time		Measurement Unit Time	
Pulse No. of per Rotation		Pulse No. of per Rotation	
High Speed Compare Table	Counter CH	—	
	Comparison Type	—	
	Output Destination Device	—	
	Comparison Value 1 Specification Method	—	
	Comparison Value 1 Direct	—	
	Comparison Value 1 Indirect	—	
	Comparison Value 2 Specification Method	—	
	Comparison Value 2 Direct	—	
	Comparison Value 2 Indirect	—	
Multi-point Output High Speed Compare Table	Enable/Disable	—	
	Device	—	
	Comparison Value	—	
	Output Device	—	
	Output Data (HEX)	—	
	Table Data/Counter CH/Output Data/Points	—	
Occupied input (X) Explanation	1-Phase 1 Count (S/W Updown Switch)	CH1 to 8	
	1-Phase 1 Count (H/W Updown Switch)	CH1 to 8	
	1-Phase 2 Input	CH1 to 8	
	2 Phase Counts	CH1 to 8	
Other	Specification method for high speed counter	Specification method for high speed counter	

Pulse Width Measurement

Classification-Level 1	Classification-Level 2	Classification-Level 3
Basic Settings	Use Pulse Width Measurement	Use/Not Use
	Input Signal	Input Signal
	Logical Switch	Logical Switch
	Measurement Mode	Measurement Mode

■Positioning

Classification-Level 1	Classification-Level 2	Classification-Level 3
Basic Settings	Basic Parameters 1	Pulse Output Mode
		Output Device (PULSE/CW)
		Output Device (SIGN/CCW)
		Rotation Direction Setting
		Unit Setting
		Pulse No. of per Rotation
		Movement Amount per Rotation
		Position Data Magnification
	Basic Parameters 2	Interpolation Speed Specified Method
		Max. Speed
		Bias Speed
		Acceleration Time
		Deceleration Time
	Detailed Setting Parameter	External Start Signal Enable/Disable
		External Start Signal Device No.
		External Start Signal Logic
		Interrupt Input Signal 1 Enable/Disable
		Interrupt Input Signal 1 Mode
		Interrupt Input Signal 1 Device No.
		Interrupt Input Signal 1 Logic
		Interrupt Input Signal 2 Logic
	OPR Parameters	OPR Enable/Disable
		OPR Direction
		Starting Point Address
		Clear Signal Output Enable/Disable
		Clear Signal Output Device No.
		OPR Dwell Time
		Near-point Dog Signal Device No.
		Near-point Dog Signal Logic
		Zero Signal Device No.
		Zero Signal Logic
		Zero Signal OPR Zero Signal Counts
		Zero Signal Count Start Time
Positioning Data	Device	—
	Control Method	—
	Axis to be Interpolated	—
	Positioning Address	—
	Command Speed	—
	Dwell Time	—
	Interrupt Input Signal 2 Device No.	—
	Jump Destination Table No.	—
M No. for Jump Condition	—	

■PWM

Classification-Level 1	Classification-Level 2	Classification-Level 3
Basic Settings	Use PWM Output	Use/Not Use
	Output Signal	Output Signal
	Pulse Width/Cycle Unit	Pulse Width/Cycle Unit
	Output Pulse Logic	Output Pulse Logic
	Pulse Width	Pulse Width
	Cycle	Cycle

Input Response Time Setting

Classification-Level 1	Classification-Level 2	Classification-Level 3
Input Response Time	X0 to X377	—

Analog Input Setting

Classification-Level 1	Classification-Level 2	Classification-Level 3
Basic Settings	A/D Conversion Enable/Disable Setting Function	A/D Conversion Enable/Disable Setting
	A/D Conversion Method	Average Processing Specify Time Average Counts Average Moving Average
Application Settings	Warning Output Function	Process Alarm Warning Setting
		Process Alarm Upper Upper Limit Value
		Process Alarm Upper Lower Limit Value
		Process Alarm Lower Upper Limit Value
		Process Alarm Lower Lower Limit Value
	Over Scale Detection	Over Scale Detection Enable/Disable
	Scaling Setting	Scaling Enable/Disable
Scaling Upper Limit Value Scaling Lower Limit Value		
Shift Function	Shift Amount	
Digital Clip Setting	Digital Clip Enable/Disable	

Analog Output Setting

Classification-Level 1	Classification-Level 2	Classification-Level 3
Basic Settings	D/A Conversion Enable/Disable Setting Function	D/A Conversion Enable/Disable Setting
	D/A Output Enable/Disable Setting	D/A Output Enable/Disable Setting
Application Settings	Warning Output Function	Warning Output Setting
		Warning Upper Limit Value
		Warning Lower Limit Value
	Scaling Setting	Scaling Enable/Disable
		Scaling Upper Limit Value
		Scaling Lower Limit Value
	Shift Function	Shifting Amount
Analog Output HOLD/CLEAR Setting	HOLD/CLEAR Setting HOLD Setting Value	

Extended Board Setting

Classification-Level 1	Classification-Level 2	Classification-Level 3
Basic Settings	Extended Board	—
	Communication Protocol Type	—

Memory card parameters

Classification-Level 1	Classification-Level 2	Classification-Level 3
Boot Setting	Boot Setting	Clear the CPU built-in memory before boot
		Boot File Setting

INDEX

A

Annunciator (F) 206

B

Boot operation 104
Built-in analog 201

C

Character string constant 221
Clock function 46
Constant 221
Constant scan 84
Counter (C/LC) 212
CPU parameter 291

D

Data memory 37
Data register (D) 215
Decimal 221
Decimal constant (K) 221
Device initial value 97
Device/label access service processing setting . 107
Device/label memory 37

E

END processing 17
Error code 274
Event execution type program 25
Execution type of program 20

F

File password 32 113
File register (R) 218
Files 39
Fixed scan execution mode 23
Fixed scan execution type program 21
FX3-compatible high-speed counter 165
FX3-compatible pulse catch 188

G

Global pointer 219

H

Hexadecimal 221
Hexadecimal constant (H) 221
High-speed comparison table 132
High-speed counter 114
High-speed counter (normal mode) 124
High-speed counter
(pulse density measurement mode) 126
High-speed counter
(rotational speed measurement mode) 129
High-speed timer 209

I

I/O refresh 17
Index register setting 217
Index registers (Z/LZ) 217
Initial device value 97
Initial execution type program 20
Initial scan time 18
Input (X) 205
Internal relay (M) 206
Interrupt cause 220
Interrupt pointer (I) 219
Interrupt priority 220
Interrupt program 30

L

Label 222
Latch 99
Latch (1) 99
Latch (2) 99
Latch clear 101
Latch relay (L) 206
Link register (W) 215
Link relay (B) 206
Link special register (SW) 215
Link special relay (SB) 208
Low-speed timer 209

M

Memory card parameter 297
Memory configuration 37
Module access device 216
Module parameter 292
Multiple interrupt 53
Multiple point output, high-speed comparison table . 134

N

Nesting (N) 218

O

Online change 50
Output (Y) 205

P

PAUSE 35
PID control 55
Pointer (P) 219
Priority for interrupt cause 220
Pulse catch 184
Pulse width measurement 174
PWM 193

R

Real constant (E) 221
Remote operation 86
Remote PAUSE 88

Remote RESET	89
Remote RUN	86
Remote STOP	86
Retentive timer (ST)	209
Routine timer	209
RUN status	35

S

Scan execution type program	21
Scan monitoring function	44
Scan time	18
Scan time monitoring time setting	44
SD memory card	38
SD memory card forced stop	103
Security function	113
Security key authentication	113
Special register (SD)	215
Special relay (SM)	215
Stand-by type program	28
Step relay (S)	208
STOP status	35
Subroutine program	29
System clock	49
System device	215
System parameter	291

T

Time setting	46
Time zone	48
Timer (T/ST)	209

U

User device	205
-----------------------	-----

W

Watchdog timer	44
--------------------------	----



REVISIONS

Revision date	Revision	Description
October 2014	A	First Edition
January 2015	B	■ Added functions Fixed scan execution type program, Online change, PID control function, FX3-compatible high-speed counter function, Routine timer ■ Added or modified parts Section 1.3, 3.1, 3.2, Chapter 4, 7, 8, 9, 12, 13, 17, Section 19.2, Chapter 20, Section 21.2, Appendix 1, 2, 3, 4

This manual confers no industrial property rights or any rights of any other kind, nor does it confer any patent licenses. Mitsubishi Electric Corporation cannot be held responsible for any problems involving industrial property rights which may occur as a result of using the contents noted in this manual.

© 2014 MITSUBISHI ELECTRIC CORPORATION

WARRANTY

Please confirm the following product warranty details before using this product.

1. Gratis Warranty Term and Gratis Warranty Range

If any faults or defects (hereinafter "Failure") found to be the responsibility of Mitsubishi occurs during use of the product within the gratis warranty term, the product shall be repaired at no cost via the sales representative or Mitsubishi Service Company. However, if repairs are required onsite at domestic or overseas location, expenses to send an engineer will be solely at the customer's discretion. Mitsubishi shall not be held responsible for any re-commissioning, maintenance, or testing on-site that involves replacement of the failed module.

[Gratis Warranty Term]

The gratis warranty term of the product shall be for one year after the date of purchase or delivery to a designated place. Note that after manufacture and shipment from Mitsubishi, the maximum distribution period shall be six (6) months, and the longest gratis warranty term after manufacturing shall be eighteen (18) months. The gratis warranty term of repair parts shall not exceed the gratis warranty term before repairs.

[Gratis Warranty Range]

- 1) The range shall be limited to normal use within the usage state, usage methods and usage environment, etc., which follow the conditions and precautions, etc., given in the instruction manual, user's manual and caution labels on the product.
- 2) Even within the gratis warranty term, repairs shall be charged for in the following cases.
 - a) Failure occurring from inappropriate storage or handling, carelessness or negligence by the user. Failure caused by the user's hardware or software design.
 - b) Failure caused by unapproved modifications, etc., to the product by the user.
 - c) When the Mitsubishi product is assembled into a user's device, Failure that could have been avoided if functions or structures, judged as necessary in the legal safety measures the user's device is subject to or as necessary by industry standards, had been provided.
 - d) Failure that could have been avoided if consumable parts (battery, backlight, fuse, etc.) designated in the instruction manual had been correctly serviced or replaced.
 - e) Relay failure or output contact failure caused by usage beyond the specified life of contact (cycles).
 - f) Failure caused by external irresistible forces such as fires or abnormal voltages, and failure caused by force majeure such as earthquakes, lightning, wind and water damage.
 - g) Failure caused by reasons unpredictable by scientific technology standards at time of shipment from Mitsubishi.
 - h) Any other failure found not to be the responsibility of Mitsubishi or that admitted not to be so by the user.

2. Onerous repair term after discontinuation of production

- 1) Mitsubishi shall accept onerous product repairs for seven (7) years after production of the product is discontinued.
Discontinuation of production shall be notified with Mitsubishi Technical Bulletins, etc.
- 2) Product supply (including repair parts) is not available after production is discontinued.

3. Overseas service

Overseas, repairs shall be accepted by Mitsubishi's local overseas FA Center. Note that the repair conditions at each FA Center may differ.

4. Exclusion of loss in opportunity and secondary loss from warranty liability

Regardless of the gratis warranty term, Mitsubishi shall not be liable for compensation of damages caused by any cause found not to be the responsibility of Mitsubishi, loss in opportunity, lost profits incurred to the user or third person by failure of Mitsubishi products, special damages and secondary damages whether foreseeable or not, compensation for accidents, and compensation for damages to products other than Mitsubishi products, replacement by the user, maintenance of on-site equipment, start-up test run and other tasks.

5. Changes in product specifications

The specifications given in the catalogs, manuals or technical documents are subject to change without prior notice.

6. Product application

- 1) In using the Mitsubishi MELSEC programmable controller, the usage conditions shall be that the application will not lead to a major accident even if any problem or fault should occur in the programmable controller device, and that backup and fail-safe functions are systematically provided outside of the device for any problem or fault.
- 2) The Mitsubishi programmable controller has been designed and manufactured for applications in general industries, etc. Thus, applications in which the public could be affected such as in nuclear power plants and other power plants operated by respective power companies, and applications in which a special quality assurance system is required, such as for railway companies or public service purposes shall be excluded from the programmable controller applications.
In addition, applications in which human life or property that could be greatly affected, such as in aircraft, medical applications, incineration and fuel devices, manned transportation, equipment for recreation and amusement, and safety devices, shall also be excluded from the programmable controller range of applications.
However, in certain cases, some applications may be possible, providing the user consults their local Mitsubishi representative outlining the special requirements of the project, and providing that all parties concerned agree to the special circumstances, solely at the user's discretion.

TRADEMARKS

Microsoft® and Windows® are either registered trademarks or trademarks of Microsoft Corporation in the United States and/or other countries.

Ethernet is a trademark of Xerox Corporation.

MODBUS® is a registered trademark of Schneider Electric SA.

SD logo and SDHC logo are trademarks or registered trademarks of SD-3C, LLC.



The company name and the product name to be described in this manual are the registered trademarks or trademarks of each company.

Manual number: JY997D55401B

Model: FX5-U-OU-E

Model code: 09R537

When exported from Japan, this manual does not require application to the Ministry of Economy, Trade and Industry for service transaction permission.

mitsubishi electric corporation

HEAD OFFICE: TOKYO BUILDING, 2-7-3 MARUNOUCHI, CHIYODA-KU, TOKYO 100-8310, JAPAN
HIMEJI WORKS: 840, CHIYODA MACHI, HIMEJI, JAPAN

Specifications are subject to change without notice.

HEADQUARTERS		EUROPEAN REPRESENTATIVES		EUROPEAN REPRESENTATIVES		EURASIAN REPRESENTATIVES	
Mitsubishi Electric Europe B.V. Gothaer Straße 8 D-40880 Ratingen Phone: +49 (0)2102 / 486-0 Fax: +49 (0)2102 / 486-1120	EUROPE	GEVA Wiener Straße 89 A-2500 Baden Phone: +43 (0)2252 / 85 55 20 Fax: +43 (0)2252 / 488 60	AUSTRIA	Beijer Electronics SIA Ritausmas iela 23 LV-1058 Riga Phone: +371 (0)6 / 784 2280 Fax: +371 (0)6 / 784 2281	LATVIA	TOO Kazpromavtomatika UL. ZHAMBYLA 28, KAZ-100017 Karaganda Phone: +7 7212 / 50 10 00 Fax: +7 7212 / 50 11 50	KAZAKHSTAN
Mitsubishi Electric Europe B.V. Radlická 751/113e Avenir Business Park CZ-158 00 Praha 5 Phone: +420 251 551 470 Fax: +420 251 551 471	CZECH REP.	000 TECHNIKON Prospect Nezavisimosti 177-9 BY-220125 Minsk Phone: +375 (0)17 / 393 1177 Fax: +375 (0)17 / 393 0081	BELARUS	Beijer Electronics UAB Goštautų g. 3 LT-48324 Kaunas Phone: +370 37 262707 Fax: +370 37 455605	LITHUANIA	MIDDLE EAST REPRESENTATIVE	
Mitsubishi Electric Europe B.V. 25, Boulevard des Bouvets F-92741 Nanterre Cedex Phone: +33 (0)1 / 55 68 55 68 Fax: +33 (0)1 / 55 68 57 57	FRANCE	ESCO DRIVES Culliganlaan 3 BE-1831 Diegem Phone: +32 (0)2 / 717 64 60 Fax: +32 (0)2 / 717 64 61	BELGIUM	ALFATRADE Ltd. 99, Paola Hill Malta-Paola PLA 1702 Phone: +356 (0)21 / 697 816 Fax: +356 (0)21 / 697 817	MALTA	GIRIT CELADON Ltd. 12 H'aomanut Street IL-42505 Netanya Phone: +972 (0)9 / 863 39 80 Fax: +972 (0)9 / 885 24 30	ISRAEL
Mitsubishi Electric Europe B.V. Westgate Business Park, Ballymount IRL-Dublin 24 Phone: +353 (0)1 4198800 Fax: +353 (0)1 4198890	IRELAND	KONING & HARTMAN B.V. Woluwelaan 31 BE-1800 Vilvoorde Phone: +32 (0)2 / 257 02 40 Fax: +32 (0)2 / 257 02 49	BELGIUM	INTEHSIS SRL bld. Traian 23/1 MD-2060 Kishinev Phone: +373 (0)22 / 66 4242 Fax: +373 (0)22 / 66 4280	MOLDOVA	CEG LIBAN Cebaco Center/Block A Autostrade DORA Lebanon-Beirut Phone: +961 (0)1 / 240 445 Fax: +961 (0)1 / 240 193	LEBANON
Mitsubishi Electric Europe B.V. Viale Colleoni 7 Palazzo Sirio I-20864 Agrate Brianza (MB) Phone: +39 039 / 60 53 1 Fax: +39 039 / 60 53 312	ITALY	INEA RBT d.o.o. Stegne 11 SI-1000 Ljubljana Phone: +386 (0)1 / 513 8116 Fax: +386 (0)1 / 513 8170	BOSNIA AND HERZEGOVINA	HIFLEX AUTOM. B.V. Wolweverstraat 22 NL-2984 CD Ridderkerk Phone: +31 (0)180 / 46 60 04 Fax: +31 (0)180 / 44 23 55	NETHERLANDS	AFRICAN REPRESENTATIVE	
Mitsubishi Electric Europe B.V. Nijverheidsweg 23a NL-3641RP Mijdrecht Phone: +31 (0) 297250350	NETHERLANDS	AKHNATON 4, Andrei Ljapchev Blvd., PO Box 21 BG-1756 Sofia Phone: +359 (0)2 / 817 6000 Fax: +359 (0)2 / 97 44 06 1	BULGARIA	KONING & HARTMAN B.V. Energieweg 1 NL-2627 AP Delft Phone: +31 (0)15 260 99 06 Fax: +31 (0)15 261 9194	NETHERLANDS	ADROIT TECHNOLOGIES 20 Waterford Office Park 189 Witkoppen Road ZA-Fourways Phone: +27 (0)11 / 658 8100 Fax: +27 (0)11 / 658 8101	SOUTH AFRICA
Mitsubishi Electric Europe B.V. ul. Krakowska 50 PL-32-083 Balice Phone: +48 (0) 12 347 65 00 Fax: +48 (0) 12 347 65 01	POLAND	INEA CR Losinjska 4 a HR-10000 Zagreb Phone: +385 (0)1 / 36 940 - 01/ -02/ -03 Fax: +385 (0)1 / 36 940 - 03	CROATIA	Beijer Electronics AS Postboks 487 NO-3002 Drammen Phone: +47 (0)32 / 24 30 00 Fax: +47 (0)32 / 84 85 77	NORWAY		
Mitsubishi Electric (Russia) LLC 52, bld. 1 Kosmodamianskaya emb. RU-115054 Moscow Phone: +7 495 / 721 2070 Fax: +7 495 / 721 2071	RUSSIA	AutoCont C. S. S.R.O. Kačkova 1853/3 CZ-702 00 Ostrava 2 Phone: +420 595 691 150 Fax: +420 595 691 199	CZECH REPUBLIC	Fonseca S.A. R. João Francisco do Casal 87/89 PT-3801-997 Aveiro, Esqueiroa Phone: +351 (0)234 / 303 900 Fax: +351 (0)234 / 303 910	PORTUGAL		
Mitsubishi Electric Europe B.V. Carretera de Rubi 76-80 Apdo. 420 E-08190 Sant Cugat del Vallés (Barcelona) Phone: +34 (0) 93 / 5653131 Fax: +34 (0) 93 / 5891579	SPAIN	Beijer Electronics A/S Lykkegardsvej 17 DK-4000 Roskilde Phone: +45 (0)46 / 75 76 66 Fax: +45 (0)46 / 75 56 26	DENMARK	SIRIUS TRADING & SERVICES SRL Aleea Lacul Morii Nr. 3 RO-060841 Bucuresti, Sector 6 Phone: +40 (0)21 / 430 40 06 Fax: +40 (0)21 / 430 40 02	ROMANIA		
Mitsubishi Electric Europe B.V. (Scandinavia) Fjellievägen 8 SE-22736 Lund Phone: +46 (0) 8 625 10 00 Fax: +46 (0) 46 39 70 18	SWEDEN	HANS FÖLSGAARD A/S Theilgaardstr. 1 DK-4600 Køge Phone: +45 4320 8600 Fax: +45 4396 8855	DENMARK	INEA SR d.o.o. Ul. Karadjordjeva 12/217 SER-11300 Smederevo Phone: +386 (026) 461 54 01	SERBIA		
Mitsubishi Electric Turkey Elektrik Ürünleri A.Ş. Fabrika Otomasyon Merkezi Şerifali Mahallesi Nutuk Sokak No.5 TR-34775 Ümraniye-İSTANBUL Phone: +90 (0)216 / 526 39 90 Fax: +90 (0)216 / 526 39 95	TURKEY	Beijer Electronics Eesti OÜ Pärnu mnt.160i EE-11317 Tallinn Phone: +372 (0)6 / 51 81 40 Fax: +372 (0)6 / 51 81 49	ESTONIA	SIMAP SK (Západné Slovensko) Jána Derku 1671 SK-911 01 Trenčín Phone: +421 (0)32 743 04 72 Fax: +421 (0)32 743 75 20	SLOVAKIA		
Mitsubishi Electric Europe B.V. Travellers Lane UK-Hatfield, Herts. AL10 8XB Phone: +44 (0)1707 / 28 87 80 Fax: +44 (0)1707 / 27 86 95	UK	Beijer Electronics OY Vanha Nurmijärventie 62 FIN-01670 Vantaa Phone: +358 (0)207 / 463 500 Fax: +358 (0)207 / 463 501	FINLAND	INEA RBT d.o.o. Stegne 11 SI-1000 Ljubljana Phone: +386 (0)1 / 513 8116 Fax: +386 (0)1 / 513 8170	SLOVENIA		
Mitsubishi Electric Europe B.V. Dubai Silicon Oasis United Arab Emirates - Dubai Phone: +971 4 3724716 Fax: +971 4 3724721	UAE	PROVENDOR OY Teljänkatu 8 A3 FIN-28130 Pori Phone: +358 (0) 2 / 522 3300 Fax: +358 (0) 2 / 522 3322	FINLAND	Beijer Electronics Automation AB Box 426 SE-20124 Malmö Phone: +46 (0)40 / 35 86 00 Fax: +46 (0)40 / 93 23 01	SWEDEN		
Mitsubishi Electric Corporation Tokyo Building 2-7-3 Marunouchi, Chiyoda-ku Tokyo 100-8310 Phone: +81 (3) 3218-2111 Fax: +81 (3) 3218-2185	JAPAN	UTECO A.B.E.E. 5, Mavrogenou Str. GR-18542 Piraeus Phone: +30 (0)211 / 1206-900 Fax: +30 (0)211 / 1206-999	GREECE	OMNI RAY AG Im Schörl 5 CH-8600 Dübendorf Phone: +41 (0)44 / 802 28 80 Fax: +41 (0)44 / 802 28 28	SWITZERLAND		
Mitsubishi Electric Automation, Inc. 500 Corporate Woods Parkway Vernon Hills, IL 60061 Phone: +1 (847) 478-2100 Fax: +1 (847) 478-0328	USA	MELTRADE Kft. Fertő utca 14. HU-1107 Budapest Phone: +36 (0)1 / 431-9726 Fax: +36 (0)1 / 431-9727	HUNGARY	OOO "CSC-AUTOMATION" 4-B, M. Raskovoy St. UA-02660 Kiev Phone: +380 (0)44 / 494 33 44 Fax: +380 (0)44 / 494-33-66	UKRAINE		