



**MITSUBISHI**  
PROGRAMMABLE CONTROLLERS  
MELSEC-F

*Changes for the Better*

**USER'S MANUAL**

**FX3U-64DP-M PROFIBUS-DP Master Block**



**FX3U**





# Safety Precautions

(Read these precautions before use.)

Before installation, operation, maintenance or inspection of this product, thoroughly read through and understand this manual and all of the associated manuals. Also, take care to handle the module properly and safely.

This manual classifies the safety precautions into two categories:  **DANGER** and  **CAUTION**.

 <b>DANGER</b>	Indicates that incorrect handling may cause hazardous conditions, resulting in death or severe injury.
 <b>CAUTION</b>	Indicates that incorrect handling may cause hazardous conditions, resulting in medium or slight personal injury or physical damage.

Depending on the circumstances, procedures indicated by  **CAUTION** may also cause severe injury. It is important to follow all precautions for personal safety.

Store this manual in a safe place so that it can be taken out and read whenever necessary. Always forward it to the end user.

## 1. DESIGN PRECAUTIONS



 <b>DANGER</b>	Reference Page
<ul style="list-style-type: none"> <li>• Make sure to have the following safety circuits outside of the PLC to ensure safe system operation even during external power supply problems or PLC failure. Otherwise, malfunctions may cause serious accidents.                             <ol style="list-style-type: none"> <li>1) An emergency stop circuit, a protection circuit, an interlock circuit for opposite movements, such as normal and reverse rotations, and an interlock circuit for preventing damage to the machine at the upper and lower positioning limits should be configured on the outside of the PLC.</li> <li>2) Note that when the PLC CPU detects an error, such as a watchdog timer error, during self-diagnosis, all outputs are turned off. Also, when an error that cannot be detected by the PLC CPU occurs in an input/output control block, output control may be disabled. Design external circuits and mechanisms to ensure safe operations of the machine in such a case.</li> <li>3) Note that when some sort of error occurs in a relay, triac or transistor of the output unit/block, output may be kept on or off. For output signals that may lead to serious accidents, design external circuits and mechanisms to ensure safe operations of the machine.</li> </ol> </li> </ul>	23 26

 <b>CAUTION</b>	Reference Page
<ul style="list-style-type: none"> <li>• Make sure to observe the precautions below to prevent damages to the system due to the abnormal data writing by noise to the PLC:                             <ol style="list-style-type: none"> <li>1) Do not bundle the control line together with or lay it close to the main circuit or power line. As a guideline, lay the control line at least 100mm (3.94") or more away from the main circuit or power line. Noise may cause malfunctions.</li> <li>2) Ground the shield wire with the PLC. Do not ground together with high voltage lines.</li> </ol> </li> <li>• Install module so that excessive force will not be applied to peripheral device connectors. Failure to do so may result in wire damage/breakage or PLC failure.</li> </ul>	23 26 31



# Safety Precautions

(Read these precautions before use.)

## 2. INSTALLATION PRECAUTIONS

 <b>DANGER</b>	Reference Page
<ul style="list-style-type: none"><li>• Make sure to cut off all phases of the power supply externally before attempting installation or wiring work. Failure to do so may cause electric shock.</li></ul>	26
 <b>CAUTION</b>	Reference Page
<ul style="list-style-type: none"><li>• Use the product within the generic environment specifications described in the PLC main unit manual (Hardware Edition). Never use the product in areas with dust, oily smoke, conductive dusts, corrosive gas (salt air, Cl<sub>2</sub>, H<sub>2</sub>S, SO<sub>2</sub>, or NO<sub>2</sub>), flammable gas, vibration or impacts, or exposed to high temperature, condensation, or wind and rain. If the product is used in such conditions, electric shock, fire, malfunction, deterioration or damage may occur.</li><li>• Install the product securely using a DIN rail or mounting screws.</li><li>• Install the product on a flat surface. If the mounting surface is rough, undue force will be applied to the PC board, thereby causing nonconformities.</li><li>• When drilling screw holes or wiring, make sure cutting or wire debris does not enter the ventilation slits. Failure to do so may cause fire, equipment failures or malfunctions.</li><li>• Be sure to remove the dust proof sheet from the PLC's ventilation port when the installation work is completed. Failure to do so may cause fire, equipment failures, and malfunctions.</li><li>• Connect the extension and communication cables securely to their designated connectors. Unsecured connection may cause malfunctions.</li><li>• Do not touch the conductive parts of the product directly to avoid failure or malfunctions.</li></ul>	27

## 3. WIRING PRECAUTIONS

 <b>DANGER</b>	Reference Page
<ul style="list-style-type: none"><li>• Cut off all phases of the power supply externally before installation or wiring work in order to avoid damage to the product or electric shock.</li></ul>	31
 <b>CAUTION</b>	Reference Page
<ul style="list-style-type: none"><li>• When drilling screw holes or wiring, make sure cutting or wire debris does not enter the ventilation slits. Failure to do so may cause fire, equipment failures or malfunctions.</li></ul>	31

# Safety Precautions

(Read these precautions before use.)

## 4. STARTUP AND MAINTENANCE PRECAUTIONS

 <b>DANGER</b>	Reference Page
<ul style="list-style-type: none"><li>• Do not touch any terminal while the PLC's power is on. Doing so may cause electric shock or malfunctions.</li><li>• Before cleaning or retightening terminals, externally cut off all phases of the power supply. Failure to do so may cause electric shock.</li><li>• Before modifying or disrupting the program in operation or running the PLC, carefully read through this manual and the associated manuals and ensure the safety of the operation. An operation error may damage the machinery or cause accidents.</li></ul>	23 97 100 116

 <b>CAUTION</b>	Reference Page
<ul style="list-style-type: none"><li>• Do not disassemble or modify the unit. Doing so may cause fire, equipment failures, or malfunctions. * For repair, contact your local Mitsubishi Electric distributor.</li><li>• Do not drop the product and exert strong impact. Doing so may cause damage.</li><li>• Turn off the power to the PLC before attaching or detaching the peripheral devices. Failure to do so may cause equipment failures or malfunctions.</li></ul>	23 97 100 116

## 5. DISPOSAL PRECAUTIONS

 <b>CAUTION</b>	Reference Page
<ul style="list-style-type: none"><li>• Please contact a certified electronic waste disposal company for the environmentally safe recycling and disposal of your device.</li></ul>	24

## 6. TRANSPORTATION PRECAUTIONS

 <b>CAUTION</b>	Reference Page
<ul style="list-style-type: none"><li>• The PLC is a precision instrument. During transportation, avoid impacts. After transportation, verify the operations of the products.</li></ul>	24



# FX3U-64DP-M PROFIBUS-DP Master Block

## User's Manual

Manual number	JY997D19201
Manual revision	B
Date	4/2006

### Foreword

---

This manual contains text, diagrams and explanations which will guide the reader in the correct installation, safe use and operation of the FX3U-64DP-M and should be read and understood before attempting to install or use the unit.

Store this manual in a safe place so that you can take it out and read it whenever necessary. Always forward it to the end user.

This manual confers no industrial property rights or any rights of any other kind, nor does it confer any patent licenses. Mitsubishi Electric Corporation cannot be held responsible for any problems involving industrial property rights which may occur as a result of using the contents noted in this manual.

## Outline Precautions

---

- This manual provides information for the use of the FX3u-64DP-M. The manual has been written to be used by trained and competent personnel. The definition of such a person or persons is as follows;
  - a) Any engineer who is responsible for the planning, design and construction of automatic equipment using the product associated with this manual should be of a competent nature, trained and qualified to the local and national standards required to fulfill that role. These engineers should be fully aware of all aspects of safety with regards to automated equipment.
  - b) Any commissioning or service engineer must be of a competent nature, trained and qualified to the local and national standards required to fulfill that job. These engineers should also be trained in the use and maintenance of the completed product. This includes being completely familiar with all associated documentation for the said product. All maintenance should be carried out in accordance with established safety practices.
  - c) All operators of the completed equipment should be trained to use that product in a safe and coordinated manner in compliance to established safety practices. The operators should also be familiar with documentation which is connected with the actual operation of the completed equipment.

**Note:** the term 'completed equipment' refers to a third party constructed device which contains or uses the product associated with this manual

- This product has been manufactured as a general-purpose part for general industries, and has not been designed or manufactured to be incorporated in a device or system used in purposes related to human life.
- Before using the product for special purposes such as nuclear power, electric power, aerospace, medicine or passenger movement vehicles, consult with Mitsubishi Electric.
- This product has been manufactured under strict quality control. However when installing the product where major accidents or losses could occur if the product fails, install appropriate backup or failsafe functions in the system.
- When combining this product with other products, please confirm the standard and the code, or regulations with which the user should follow. Moreover, please confirm the compatibility of this product to the system, machine, and apparatus with which the user is using.
- If in doubt at any stage during the installation of the product, always consult a professional electrical engineer who is qualified and trained to the local and national standards. If in doubt about the operation or use, please consult the nearest Mitsubishi Electric distributor.
- Since the examples indicated by this manual, technical bulletin, catalog, etc. are used as a reference, please use it after confirming the function and safety of the equipment and system. Mitsubishi Electric will accept no responsibility for actual use of the product based on these illustrative examples.
- This manual content, specification etc. may be changed without a notice for improvement.
- The information in this manual has been carefully checked and is believed to be accurate; however, if you have noticed a doubtful point, a doubtful error, etc., please contact the nearest Mitsubishi Electric distributor.

## Registration

---

- Microsoft® and Windows® are either registered trademarks or trademarks of Microsoft Corporation in the United States and/or other countries.
- The company and product names described in this manual are the registered trademarks or trademarks of their respective companies.



# Table of Contents

<b>SAFETY PRECAUTIONS</b> .....	<b>i</b>
<b>Applicable Standards</b> .....	<b>7</b>
<b>Location and Usage of Manual</b> .....	<b>8</b>
<b>Associated Manuals</b> .....	<b>9</b>
<b>Generic Terms and Abbreviations</b> .....	<b>10</b>
<b>Reading of the Manual</b> .....	<b>11</b>

---

<b>1. Introduction</b>	<b>12</b>
------------------------	-----------

---

1.1 Features of the FX3U-64DP-M .....	12
1.2 External Dimensions and Each Part Name .....	13
1.2.1 External Dimensions and Each Part Name .....	13
1.2.2 Pin Configuration of PROFIBUS-DP Connector .....	14
1.3 System Configuration .....	14
1.3.1 Applicable PROFIBUS-DP Network .....	14
1.3.2 Applicable PLC .....	17
1.4 Communication Time .....	18
1.4.1 Communication Time .....	18
1.4.2 PROFIBUS (Bus) Cycle Time .....	19
1.5 System Start-up Procedure .....	22

---

<b>2. Specifications</b>	<b>23</b>
--------------------------	-----------

---

2.1 General Specifications .....	24
2.2 Power Supply Specifications .....	24
2.3 Performance Specifications .....	25

---

<b>3. Installation</b>	<b>26</b>
------------------------	-----------

---

3.1 Arrangements .....	28
3.2 Mounting .....	29
3.2.1 Direct Mounting .....	29
3.2.2 DIN Rail Mounting .....	30

---

<b>4. Wiring</b>	<b>31</b>
------------------	-----------

---

4.1 Applicable Cable and Connector .....	31
4.2 PROFIBUS-DP Wiring .....	32
4.3 Grounding .....	32
4.4 Bus Terminator .....	32

---

**5. Mode, Data Communication, Global Control 33**

---

5.1 Cyclic I/O Data Communication .....	33
5.1.1 Mode in Cyclic I/O Data Communication .....	33
5.1.2 Normal Service Mode (Mode 0).....	34
5.1.3 Extended Service Mode (Mode 3).....	35
5.2 Acyclic I/O Data Communication.....	36
5.3 Diagnostic Information .....	37
5.3.1 Slave Diagnostic.....	37
5.3.2 Alarm Message.....	38
5.4 Global Control .....	38
5.4.1 SYNC and UNSYNC Global Control .....	39
5.4.2 FREEZE and UNFREEZE Global Control.....	40

---

**6. Allocation of Buffer Memories (BFMs) 41**

---

6.1 Buffer Memories (BFM) Lists .....	41
6.2 Communication Status [BFM #0] .....	46
6.3 Communication Control Flags [BFM #1] .....	47
6.4 Consistency Handling Error Flags [BFM #2] .....	48
6.5 PROFIBUS Error Flags [BFM #3] .....	49
6.6 Dwell Time Flag / Whole Config Data Exchange Flag [BFM #4].....	49
6.7 Module READY Signal [BFM #5] .....	50
6.8 PROFIBUS (Bus) Cycle Time [BFM #6 to #8].....	50
6.9 Acyclic Slave Communication Deactivation Message Flags [BFM #18 to #21] .....	50
6.10 PROFIBUS Module ID (PNO ID) [BFM #26] .....	51
6.11 Master Reset [BFM #27] .....	51
6.12 Setting Error Flags [BFM #28].....	51
6.13 Master Error Status [BFM #29] .....	52
6.13.1 Master Reset Status Flag [BFM #29 Bit 0] .....	52
6.13.2 Master Hardware Error [BFM #29 Bit 1] .....	52
6.13.3 Slave Parameter Error [BFM #29 Bit 3].....	52
6.13.4 Setting Error Flag [BFM #29 Bit 4].....	53
6.13.5 Consistency Error Flag [BFM #29 Bit 5] .....	53
6.13.6 Acyclic Communication Deactivation Message Flag [BFM #29 Bit 7] .....	53
6.13.7 PROFIBUS Error Flag [BFM #29 Bit 8] .....	53
6.13.8 Slave Diagnosis Available Flag [BFM #29 Bit 9] .....	53
6.13.9 Alarm Message Available Flag [BFM #29 Bit 10] .....	53
6.13.10 No Configuration Available Flag [BFM #29 Bit 11] .....	53
6.13.11 Mode Change Not Possible Flag [BFM #29 Bit 12] .....	54
6.13.12 Diagnosis FIFO Full [BFM #29 Bit 13].....	54
6.13.13 Data Exchange Error [BFM #29 Bit 14] .....	54
6.13.14 Slave Change Address Error [BFM #29 Bit 15].....	54
6.14 Module ID Code [BFM #30].....	54
6.15 PROFIBUS Master Address [BFM #31] .....	54
6.16 PROFIBUS Transmission Speed [BFM #32] .....	55
6.17 Clear Control Flag [BFM #33] .....	55
6.18 PROFIBUS Error Mask Flag [BFM #34].....	56
6.19 Number of Allocated Slaves [BFM #38] .....	56
6.20 Operation Service Mode [BFM #39].....	56
6.21 Data Swap Activate Flag [BFM #73 to #76] .....	57
6.22 Change Slave FDL Address [BFM #81 to #83] .....	57
6.23 Cyclic Input Data .....	58
6.23.1 Cyclic Input Data Consistency Activate/Deactivate Flags [BFM #84 to #87].....	59
6.23.2 Cyclic Input Data Request Flags [BFM #100 to #163].....	59
6.23.3 Cyclic Input Data Area in Normal Service Mode [BFM #350 to #1373].....	60
6.23.4 Cyclic Input Data Area in Extended Service Mode [BFM #350 to #1373] .....	61

6.24 Cyclic Output Data .....	62
6.24.1 Cyclic Output Data Consistency Activate/Deactivate Flags [BFM #92 to #95].....	63
6.24.2 Cyclic Output Data Send Flags [BFM #225 to #288].....	63
6.24.3 Cyclic Output Data Area in Normal Service Mode [BFM #2350 to #3373].....	64
6.24.4 Cyclic Output Data Area in Extended Service Mode [BFM #2350 to #3373] .....	65
6.25 Acyclic Input Data .....	66
6.25.1 Acyclic Input Data Request Flags [BFM #4500 to #4503].....	67
6.25.2 Acyclic Input Data Area [BFM #4520 to #5015].....	67
6.26 Acyclic Output Data.....	68
6.26.1 Acyclic Output Data Send Flags [BFM #4510 to #4513].....	69
6.26.2 Acyclic Output Data Area [BFM #5760 to #6255].....	69
6.27 Master/Slave Internal Slave Parameter Error Flags [BFM #7000 to #7003].....	70
6.28 Master/Slave Internal Slave Parameter Error Data [BFM #7008 to #7071] .....	70
6.29 Slave Diagnostic Information .....	71
6.29.1 Slave Diagnostic Status Flags [BFM #7200 to #7203].....	72
6.29.2 Slave Diagnostic Request [BFM #7208].....	72
6.29.3 Request Slave Number [BFM #7209].....	72
6.29.4 Slave Diagnostic Information Data [BFM #7210 to #7335].....	73
6.30 Diagnostic Information FIFO .....	77
6.30.1 FIFO Diagnostic Request [BFM #7336].....	78
6.30.2 Internal FIFO Counter [BFM #7337].....	78
6.30.3 Diagnostic FIFO Data Area [BFM #7338 to #7463].....	78
6.31 Slave Diagnostic Status Data [BFM #7464 to #7591].....	79
6.32 Alarm Message .....	80
6.32.1 Automatical Acknowledge Setting [BFM #8784 to #8787].....	82
6.32.2 Alarm Acknowledge Status [BFM #8792 to #8795].....	82
6.32.3 Alarm Message Status [BFM #8800 to #8803].....	83
6.32.4 Alarm Message Counter [BFM #8808 to #8871] .....	83
6.32.5 Alarm Message Request [BFM #8933].....	83
6.32.6 Request Slave Number [BFM #8934].....	83
6.32.7 Alarm Message [BFM #8935 to #8969].....	84
6.32.8 Alarm ACK Request [BFM #8970].....	85
6.32.9 Slave Number [BFM #8971] .....	85
6.33 Address Information Area [BFM #9140 to #9267].....	85
6.34 Global Control .....	87
6.34.1 Global Control Area [BFM #9390] .....	87
6.34.2 SYNC and UNSYNC Global Control .....	88
6.34.3 FREEZE and UNFREEZE Global Control .....	89
6.35 Information Dwell Time Setting [BFM #9394].....	90
6.36 Cyclic Slave Status Area [BFM #9399 to #9402] .....	91
6.37 Acyclic Slave Status Area [BFM #9407 to #9410].....	91
6.38 Cyclic Input Data Start Address Area [BFM #9426 to #9489].....	92
6.39 Cyclic Output Data Start Address Area [BFM #9551 to #9614] .....	93
6.40 Number of Configured Slaves [BFM #9676] .....	94
6.41 Slave Number, Slave FDL Address, Slave PNO ID [BFM #9677 to #9868] .....	94
6.42 PROFIBUS Scan Function.....	94
6.42.1 Get DP-Slave List Request [BFM #10052].....	95
6.42.2 Configuration Difference Status [BFM #10053 to #10060].....	95
6.42.3 Scan Slave FDL Address [BFM #10061].....	96
6.42.4 Number of Detected Slave [BFM #10062].....	96
6.42.5 Detected Slave Lists [BFM #10063 to #10443].....	96

---

**7. Setting Parameters and Configuration [GX Configurator-DP] 97**

---

7.1 Master Parameter .....	98
7.2 Bus Parameter .....	99
7.3 Network Configuration.....	99

---

<b>8. Example Program</b>	<b>100</b>
8.1 Example Program 1 .....	100
8.1.1 System Configuration .....	100
8.1.2 Contents of Operation .....	100
8.1.3 Setting Network Configuration and Parameter for Example Program .....	101
8.1.4 Example Program by GX Developer .....	105
8.1.5 Example Program by GX IEC Developer (Ver. 7.00 or later) .....	108
8.2 Example Programs to Read Alarm Message from PROFIBUS-DPV1 Slave (Alarm Model) .....	112
8.2.1 An Example Program by GX Developer .....	112
8.2.2 An Example Program by GX IEC Developer (Ver. 7.00 or later).....	113
8.3 Initializing the Network .....	115
<b>9. Diagnostics</b>	<b>116</b>
9.1 Preliminary Checks .....	116
9.2 Detail Error Check.....	118
<b>Warranty.....</b>	<b>121</b>
<b>Revised History .....</b>	<b>122</b>

---

## Applicable Standards

### Compliance with EC Directive (CE Marking)

This note does not guarantee that an entire mechanical module produced in accordance with the contents of this note will comply with the following standards.

Compliance to EMC and LVD directives for the entire mechanical module should be checked by the user / manufacturer. For more details please contact the local Mitsubishi Electric sales site.

#### 1. Requirement for Compliance with EMC Directive

The following products have shown compliance through direct testing (of the identified standards below) and design analysis (through the creation of a technical construction file) to the European Directive for Electromagnetic Compatibility (89/336/EEC) when used as directed by the appropriate documentation.

**Type:** Programmable Controller (Open Type Equipment)

**Models:** MELSEC FX3U series products, identified here, manufactured from August 1st, 2005. FX3U-64DP-M: PROFIBUS-DP Master Block for FX3U Series Main Processing Units.

Standard		Remark
EN61131-2:2003	Programmable controllers - Equipment requirements and tests	Compliance with all relevant aspects of the standard. <ul style="list-style-type: none"> <li>• Radiated Emissions</li> <li>• Mains Terminal Voltage Emissions</li> <li>• RF immunity</li> <li>• Fast Transients</li> <li>• ESD</li> <li>• Conducted</li> <li>• Surge</li> <li>• Power magnetic fields</li> </ul>

#### Caution for Compliance with EC Directive

- 1) Caution for wiring  
For noise prevention please attach at least 50 mm (1.97") of the twisted-pair cable along the grounding plate to which the ground terminal is connected.  
→ For detail of wiring, refer to Section 4.2
- 2) Installation in Enclosure  
→ For details on installation in Enclosure, refer to FX3U User's Manual - Hardware Edition.

### Certification of UL, cUL Standards

The following product has UL and cUL certification.

**UL, cUL File Number:** E95239

**Models:** FX3U-64DP-M: PROFIBUS-DP Master Block for FX3U Series Main Processing Units.

## Location and Usage of Manual

The FX3u-64DP-M PROFIBUS-DP Master Block is a master (Class 1) for the PROFIBUS-DP network. By connecting the FX3u-64DP-M, the FX3u Series PLC can both read and write data from and to the slaves.

PLC

**FX3u Series PLC**



**For explanations on installation and wiring**

- Hardware Manual (Manual is supplied with product.) Supplied Manual
- User's Manual - Hardware Edition Additional Manual

**For explanations on basic/applied instructions and PLC devices**

- Programming Manual - Basic & Applied Instruction Edition Additional Manual

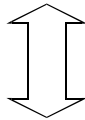

PROFIBUS-DP Master

**FX3u-64DP-M**

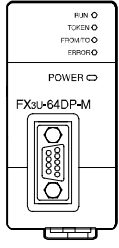

Installation manual is supplied with product.  
For detailed explanation, refer to this user's manual.

**For information on installation and wiring**

- FX3u-64DP-M Installation Manual (Manual is supplied with product.) Supplied Manual

**For detailed explanation**

- FX3u-64DP-M User's Manual Additional Manual

**This manual** This manual contains explanations on wiring, installation, specification and allocation BFM's, etc. of the FX3u-64DP-M PROFIBUS-DP Master Block.

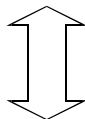

PROFIBUS-DP Slave

Obtain the manual of the slaves on the PROFIBUS-DP network. These manuals are necessary for your system.

**Slave of FX Series**

**FX2N-32DP-IF / FX0N-32NT-DP**

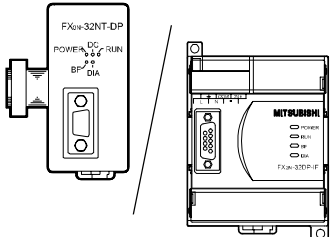

Hardware manual is supplied with product.  
For detailed explanation, refer to user's manual.

**For explanation on installation and wiring**

- Hardware Manual (Manual is supplied with product.) Supplied Manual

**For detailed explanation**

- User's Manual Additional Manual

---

**Other Slave**

Obtain the manual of the slaves on the PROFIBUS-DP network. These manuals are necessary for your system.

## Associated Manuals

For detailed explanation of FX3U-64DP-M, refer to this manual.

For the hardware information and instruction on the PLC main unit, other special function unit/block, etc., refer to its respective manual.

For acquiring required manuals, contact the distributor from who you have purchased the product.

⊙ Refer to these manuals

○ Refer to the manual required depending on the equipment used

△ For detail explanation, refer to an additional manual

		Manual Name	Manual Number	Description	Model Code
<b>Manual for the Main Module</b>					
<b>FX3U Series PLCs Main Unit</b>					
△	Supplied Manual	FX3U Series Hardware Manual	JY997D18801	Describes FX3U Series PLC specification for I/O, wiring and installation extracted from the FX3U User's Manual - Hardware Edition. For details, refer to FX3U Series User's Manual - Hardware Edition.	-
⊙	Additional Manual	FX3U Series User's Manual - Hardware Edition	JY997D16501	Describes FX3U Series PLC specification details for I/O, wiring, installation and maintenance.	09R516
<b>Programming for FX3U/FX3UC Series</b>					
⊙	Additional Manual	FX3U / FX3UC Series Programming Manual - Basic & Applied Instruction Edition	JY997D16601	Describes PLC programming for basic/applied instructions and devices.	09R517
<b>Manual for the PROFIBUS-DP Master Block, Interface Block</b>					
<b>PROFIBUS-DP Master Block</b>					
△	Supplied Manual	FX3U-64DP-M Installation Manual	JY997D19901	Describes FX3U-64DP-M PROFIBUS-DP Master Block specification for wiring and installation extracted from the FX3U-64DP-M User's Manual. For details, refer to FX3U-64DP-M User's Manual.	-
⊙	Additional Manual	FX3U-64DP-M User's Manual	JY997D19201	Describes FX3U-64DP-M PROFIBUS-DP Master Block specification details for wiring, installation and allocation BFM's, etc.	-
<b>PROFIBUS-DP Interface Block</b>					
○	Supplied Manual	FX0N-32NT-DP User's Manual	JY992D61401	Describes FX0N-32NT-DP PROFIBUS-DP Interface Unit specification details for wiring, installation and allocation BFM's, etc.	-
△	Supplied Manual	FX2N-32DP-IF Hardware Manual	JY992D77101	Describes FX2N-32DP-IF PROFIBUS-DP Interface Unit specification for wiring and installation extracted from the FX2N-32DP-IF User's Manual. For details, refer to FX2N-32DP-IF User's Manual.	-
○	Additional Manual	FX2N-32DP-IF User's Manual	JY992D79401	Describes FX2N-32DP-IF PROFIBUS-DP Interface Unit specification details for wiring, installation and allocation BFM's, etc.	-
<b>Configuration Software</b>					
⊙		GX Cofigurator-DP Configuration System for Open Networks Software Manual	-	Describes operation details of GX Cofigurator-DP Configuration System for Networks Software.	-

## Generic Terms and Abbreviations

Generic Name and Abbreviation	Description
<b>PLCs</b>	
FX3U Series	Generic name of the FX3U Series
Main unit	Abbreviated name of the FX3U Series PLC main unit
FX2N Series	Generic name of the FX2N Series
FX0N Series	Generic name of the FX0N Series
Expansion board	Generic name of the FX3U Series expansion board
Special adapter	Generic name of the FX3U Series special adapter
Special function units/block	Generic name of the FX0N/FX2N Series FX3UC Series special function block, and FX2N Series special function unit
Extension unit/block	Generic name of I/O Extension block and powered extension unit
I/O Extension block	Generic name of FX2N Series extension block
Powered extension unit	Generic name of FX2N Series powered extension unit
<b>PROFIBUS-DP Network</b>	
PROFIBUS-DP network	Abbreviated name of the PROFIBUS-DP network
DP-Master	Generic name of the PROFIBUS-DP master module (include FX3U-64DP-M)
64DP-M	Abbreviated name of FX3U-64DP-M PROFIBUS-DP master block
DP-Slave	Generic name of the PROFIBUS-DP slave module
32DP-IF	Abbreviated name of FX2N-32DP-IF PROFIBUS-DP interface block
32NT-DP	Abbreviated name of FX0N-32NT-DP PROFIBUS-DP interface block
GX Configurator-DP	Generic name of configuration system for open networks software Version 7.00A or later.
<b>Programming Tools</b>	
Programming tool	Generic name of the programming software and handy programming panel
Programming software	Generic name of the following programming software GX Developer, FX-PCS/WIN(-E)
GX Developer	Generic name of programming software packages SW□D5C-GPPW-J and SW□D5C-GPPW-E
GX IEC Developer	Generic name of programming software, GX IEC Developer Ver.7.00 or later
FX-PCS/WIN(-E)	Generic name of programming software packages FX-PCS/WIN and FX-PCS/WIN-E
Handy programming panel (HPP)	Generic name of the following models FX-20P(-E), FX-10P(-E)
RS-232/RS-422 conversion interface	Generic name of the following models FX-232AW, FX-232AWC, FX-232AWC-H
USB/RS-422 conversion interface	Abbreviated name of the FX-USB-AW USB/RS-422 Conversion Interface
<b>Manuals</b>	
Programming Manual	Abbreviated name of FX3U / FX3UC Series Programming Manual - Basic & Applied Instruction Edition
FX3U PLC Hardware Edition	Abbreviated name of FX3U Series User's Manual - Hardware Edition
Analog Control Edition	Abbreviated name of FX3U / FX3UC Series User's Manual - Analog Control Edition
Positioning Control Edition	Abbreviated name of FX3U / FX3UC Series User's Manual - Positioning Control Edition
Data Communication Edition	Abbreviated name of FX Series User's Manual - Data Communication Edition
GX Configurator-DP Software Manual	Abbreviated name of GX Configurator-DP Configuration System for Open Networks Software Manual



# Reading of the Manual

**Shows the manual title.**

This area shows the manual title for the page currently opened.

**Shows the title of the chapter and the title of the section.**

This area shows the title of the chapter and the title of the section for the page currently opened.

**Indexes the chapter number.**

The right side of each page indexes the chapter number for the page currently opened.

FX3u-64DP-M Profibus-DP Master Block  
User's Manual
3 Installation  
3.2 Mounting

**3.2 Mounting**

The 64DP-M can be mounted on a DIN rail (DIN46227) or mounted directly using screws.

**3.2.1 Direct Mounting**

The 64DP-M can be mounted with M4 screws by using the direct mounting holes. The 64DP-M mounting hole pitches are shown below.

→ For detail, refer to FX3u PLC Hardware Edition

**Point**

- Mounting screw: M4 screw.
- An interval space between each unit of 1 to 2 mm (0.04" to 0.08") is necessary.
- Mount the main unit, I/O extension units/blocks, and special function units/blocks which are installed on the left side of 64DP-M first.

**Direct Mounting Procedure**

- 1) Make mounting holes in the mounting surface referring to the above diagram.
- 2) Fit the 64DP-M (right fig. A) based on the holes, and secure it with M4 screws (right fig. B).

- 3) Connect extension cable (right fig. C) to the main unit, I/O extension unit/block, or special function unit/block to the left side.

→ For extension cable connection procedure, refer to FX3u PLC Hardware Edition

25

1	Introduction
2	Specifications
3	Installation
4	Wiring
5	Mode, Data Comm., Serial Comm.
6	Allocation of Buffer Memories
7	Setting Parameters and Configuration
8	Example Program
9	Diagnostics

**Shows the reference.**

The mark of " → " is expressing the reference destination and the reference manual.

# 1. Introduction

## 1.1 Features of the FX3U-64DP-M

The FX3U-64DP-M PROFIBUS-DP Master Block (hereafter called "64DP-M") is a master (Class 1) for the PROFIBUS-DP network. The FX3U Series PLC, when connected to the 64DP-M can read input data from the DP-Slaves, and write output data to the DP-Slaves. Only one 64DP-M can be connected directly to the FX3U series PLC's extension port, or to any other extension unit / block's right side extension port.

### 1. Controlled maximum slaves:

A 64DP-M can control a maximum of 64 slaves using repeaters on the PROFIBUS-DP network.

→ **For system configuration of the PROFIBUS-DP network, refer to Section 1.3**

### 2. Communication data and message:

The 64DP-M communicates the following I/O data and messages from/to DP-Slaves on the PROFIBUS-DP network.

→ **For details, refer to Chapter 5 and 7**

- Cyclic I/O data
- Acyclic I/O data
- Diagnostic messages  
Diagnostic messages from DP-Slaves can be stacked to a maximum of 64 entries.
- Alarm Messages of alarm model

### 3. Global control:

The 64DP-M supports SYNC global control, UNSYNC global control, FREEZE global control and UNFREEZE global control.

→ **For details, refer to Chapter 5 and 7**

### 4. Configuration setting:

Configuration of the 64DP-M can be set easily by GX Configurator-DP Configuration System for Open Networks Software (Ver. 7.00A or more). For GX Configurator-DP Configuration System for Open Networks Software (hereafter called "GX Configurator-DP"), refer to the following manual.

→ **Refer to Chapter 6 and 8**

→ **For operation details on software, GX Configurator-DP Software Manual**

### 5. Communication:

The 64DP-M supports 9.6k, 19.2k, 93.75k, 187.5k, 500k, 1.5M, 3M, 6M and 12Mbps.

The 64DP-M can be connected to a PROFIBUS-DP network by a standard 9-pin D-SUB connector and shielded twisted pair PROFIBUS cable complying with EN50170.

→ **For wiring, refer to Chapter 4**

→ **For parameter setting, refer to Chapter 6**

## 1.2 External Dimensions and Each Part Name

### 1.2.1 External Dimensions and Each Part Name

Dimensions: mm (inches) MASS (Weight): Approx. 0.2kg (0.44 lbs)  
Accessory: Special block No. label

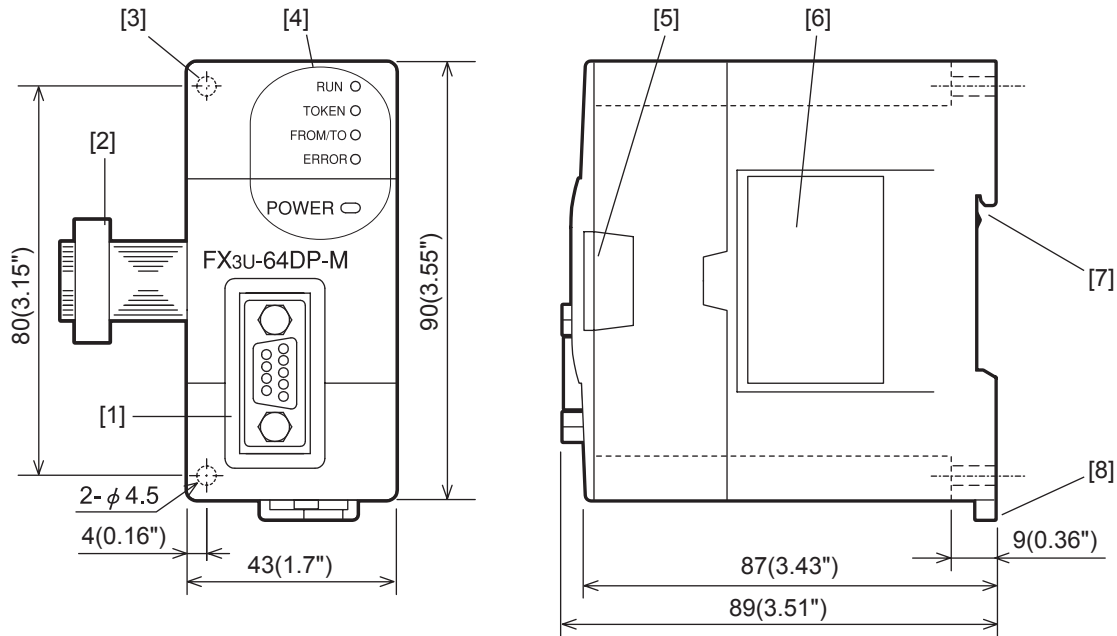

- [1] PROFIBUS-DP port (9-pin D-SUB Connector: #4-40unc inch screw thread)
- [2] Extension cable
- [3] Direct mounting hole: 2- $\phi$ 4.5 (0.18"), mounting screw: M4 screw
- [4] Status LEDs

LED Name	Color	Description	
RUN	Green	Lit	During normal operation. 64DP-M is in RUN mode, all DP-Slaves exchange data in Data Exchange mode.
		Flicker	Not all configured DP-Slaves are in data exchange. → <b>For details, refer to Section 9.1</b>
		Unlit	64DP-M is in STOP mode, or an error has occurred. → <b>For diagnostic details, refer to Section 9.1</b>
TOKEN	Green	Lit when token is maintained.	
FROM/TO	Green	Lit	PLC access to 64DP-M by FROM/TO instruction.
		Unlit	PLC does not access to 64DP-M by FROM/TO instruction.
ERROR	Red	Lit	Hardware error has occurred. → <b>For diagnostic details, refer to Section 9.1 and 9.2</b>
		Flicker	An error or problem has occurred. → <b>For diagnostic details, refer to Section 9.1 and 9.2</b>
		Unlit	During normal operation.
POWER	Green	Lit while 24V DC power is properly supplied from main unit. → <b>For other LED status, refer to Section 9.1</b>	

- [5] Extension port under the top cover
- [6] Name plate
- [7] DIN rail mounting groove (DIN rail: DIN46277)
- [8] DIN rail mounting hook

### 1.2.2 Pin Configuration of PROFIBUS-DP Connector

The connector is a 9-pin D-SUB (#4-40unc inch screw thread) type, with the pin configuration shown below.

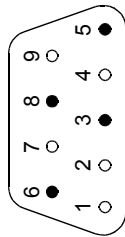

● Assigned  
○ Not assigned

Pin No.	Signal Name	Meaning
3	RXD/TXD-P	Receive/transmit-Data-P
5	DGND	Data Ground
6	VP	Voltage-Plus (5V, 90mA)
8	RXD/TXD-N	Receive/transmit-Data-N
1, 2, 4, 7, 9	NC	Pin not assigned

## 1.3 System Configuration

### 1.3.1 Applicable PROFIBUS-DP Network

- The maximum number of DP-Slaves that can be connected to a 64DP-M is 64.
- Number of units that can be connected for 1 segment  
DP-Masters + DP-Slaves + repeaters  $\leq$  32 units
- Number of units that can be connected to the entire network using repeaters.  
DP-Masters + DP-Slaves  $\leq$  126 units
- Communications can be conducted via a maximum of 3 repeaters from an arbitrary DP-Master or arbitrary DP-Slave to an arbitrary DP-Master or arbitrary DP-Slave. However, the whole network can contain more than 3 repeaters. (See note below.)

#### 1. Connecting 1 Master (Class 1) on the PROFIBUS-DP network.

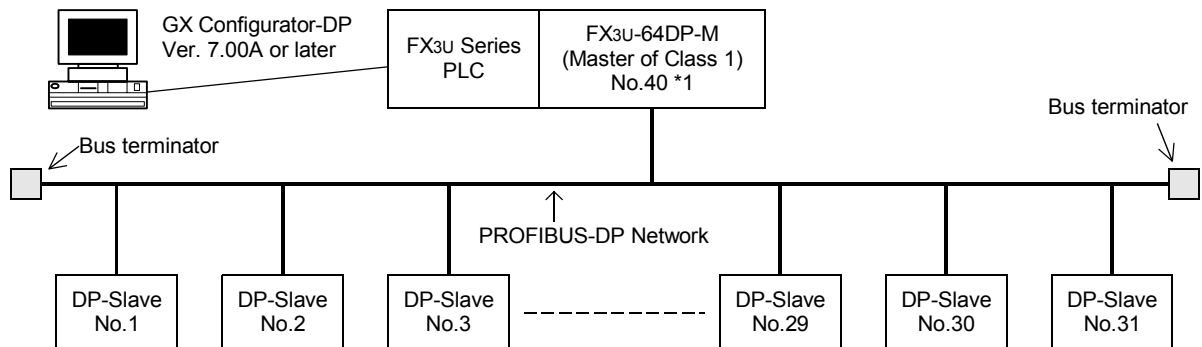

- \*1. In this system configuration, the 64DP-M can connect a maximum of 31 slaves. As the total units (DP-Masters + DP-Slaves + repeaters) is 32 units when PROFIBUS-DP network is 1 segment.

**2. Connecting 1 Master (Class 1) and 1 repeater on the PROFIBUS -DP network.**

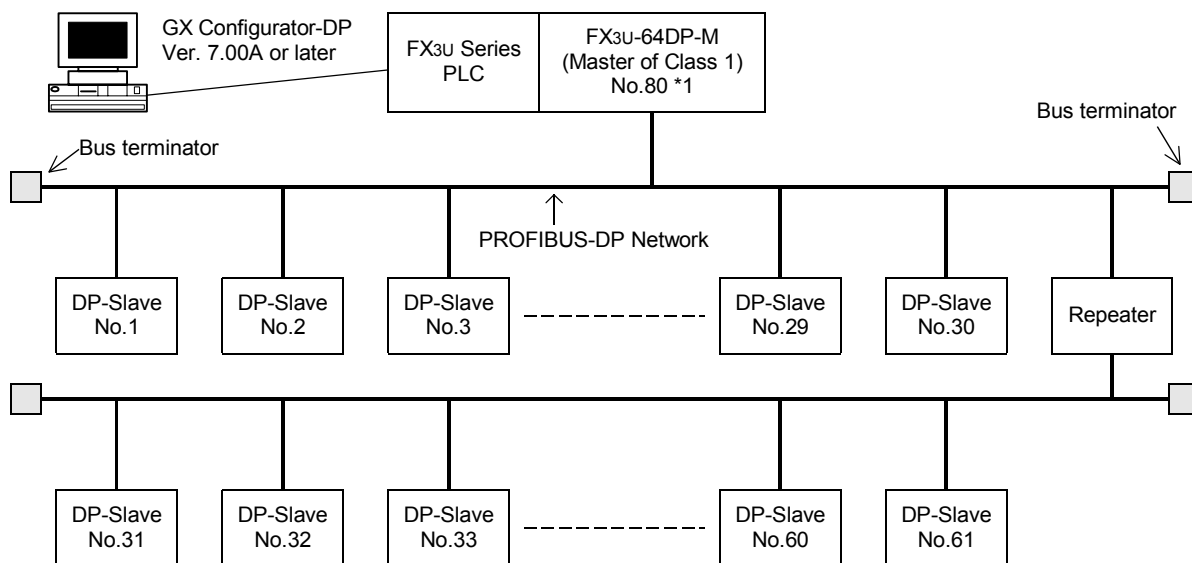

\*1. In this system configuration, the 64DP-M can connect a maximum of 61 slaves, as a repeater is used.

**3. Connecting 1 Master (Class 1) and 3 repeaters on the PROFIBUS -DP network.**

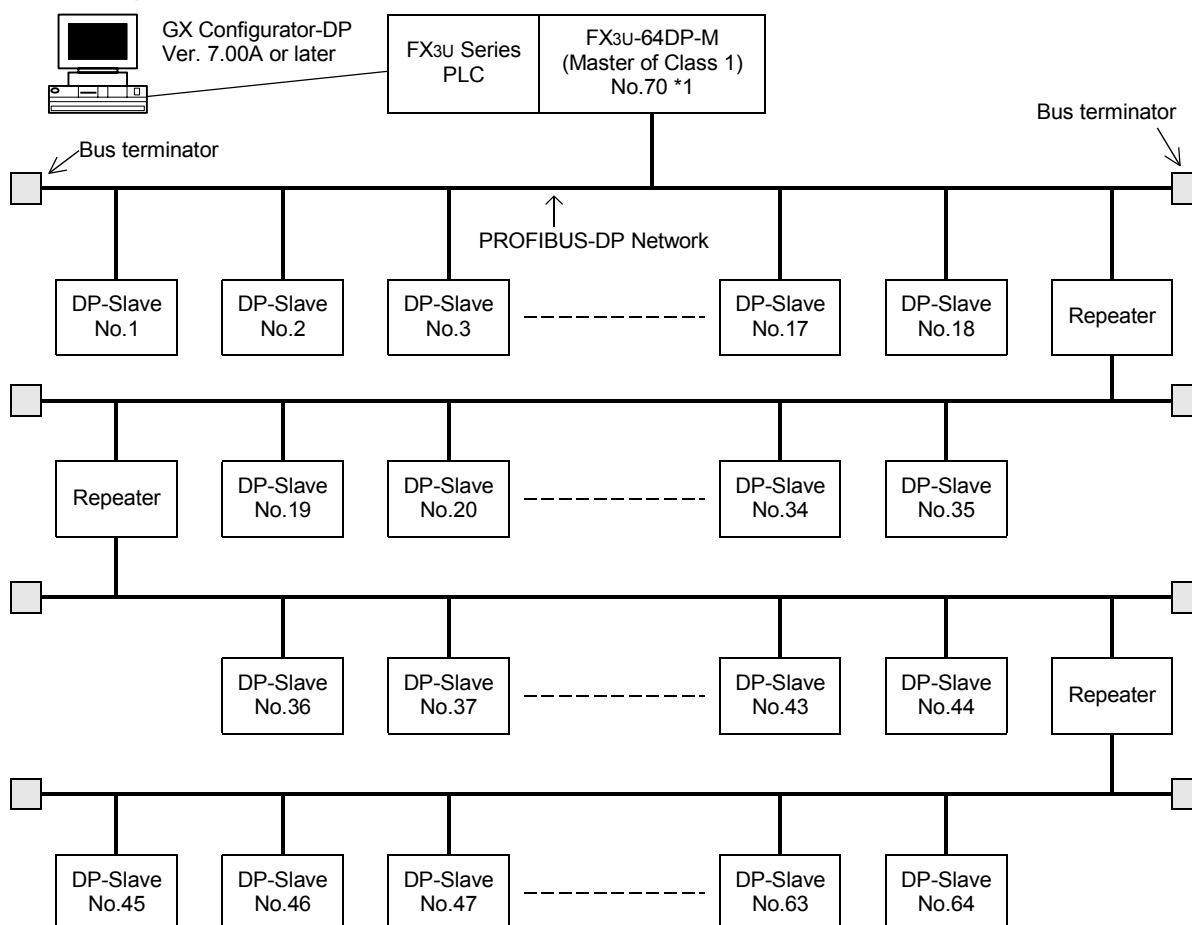

\*1. Communications can be conducted via a maximum of 3 repeaters from an arbitrary DP-Master or arbitrary DP-Slave to an arbitrary DP-Master or arbitrary DP-Slave. However, the whole network can contain more than 3 repeaters.

1	Introduction
2	Specifications
3	Installation
4	Wiring
5	Mode-Data Comms., Global Control
6	Allocation of Buffer Memories (BFMs)
7	Setting Parameters and Configuration
8	Example Program
9	Diagnostics

**4. Connecting 126 stations (3 Masters + 60 Slaves or more) on the PROFIBUS-DP network.**

→ Please see NOTE on the next page

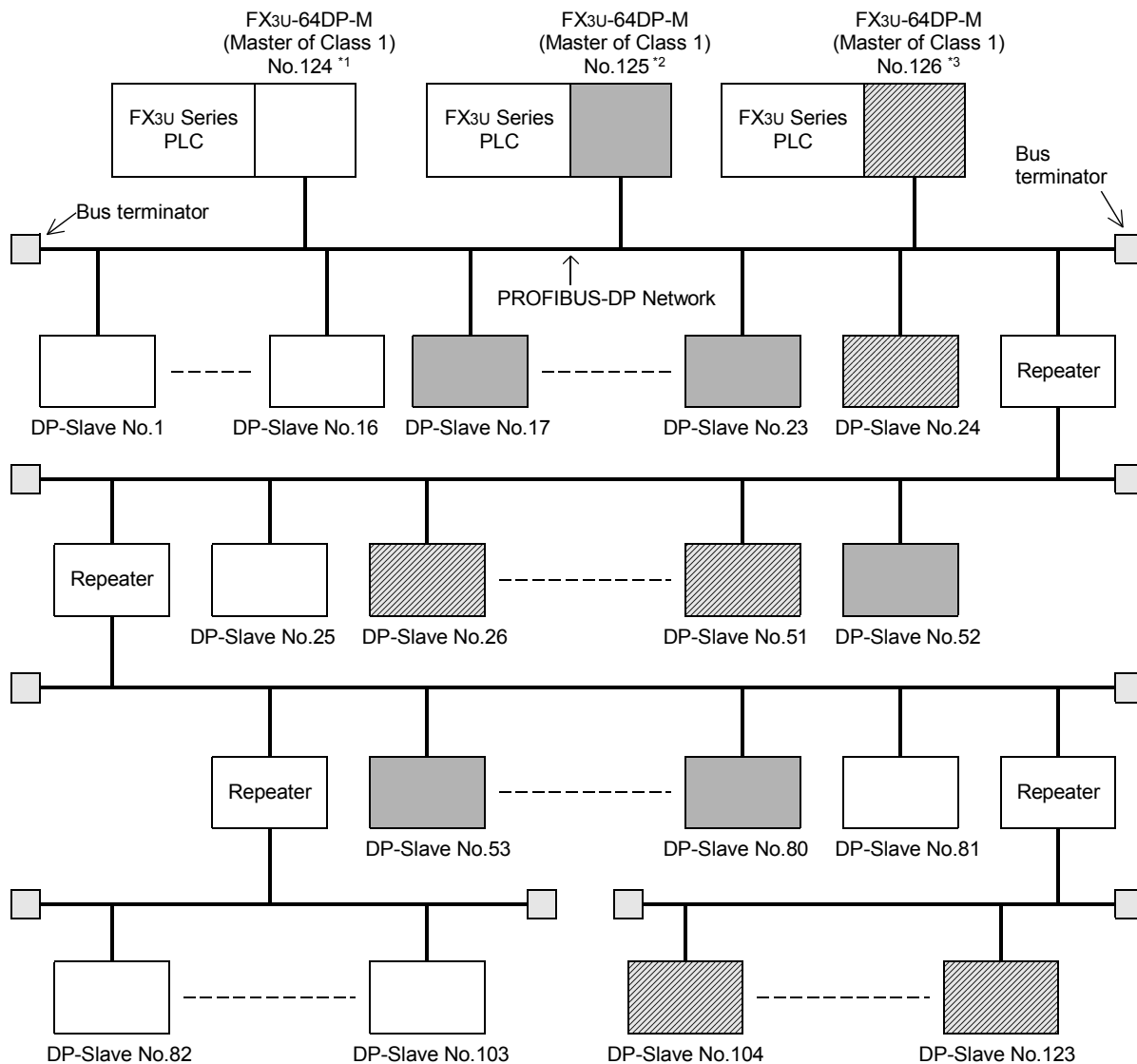

\*1. This 64DP -M has a total of 40 slaves (No.1 to 16, 25, 81 to 103).

\*2. This 64DP-M has a total of 36 slaves (No.17 to 23, 52 to 80)

\*3. This 64DP-M has a total of 47 slaves (No.24, 26 to 51, 104 to 123)

**Note**

In the multiple master network, when reconnecting a PROFIBUS cable to a DP-Master that is exchanging data at allowed baud rate, the other DP-masters may stop the communication, and the slave outputs may be turned OFF. To avoid this, connect the master PROFIBUS cable securely.  
In addition, the following value must be set in a Multi master network:

		All DP-Master (64DP-M) Settings
Master parameter	Minimum Slave Interval	Sum of PROFIBUS (bus) cycle time of all DP-Masters. For multi master networks the calculation of Minimum Slave Interval (MSI) must be done by customer. The setup must be the same for all DP-Masters.
	Transmission Speed	Transmission speed must be the same for all DP-Master.
	Watchdog	Checked
	Slave Watchdog	Set the slave watchdog timer setting value to larger than $(TTR \times G)/TS$ . TTR: Target token rotation time (Unit: Bit Time) G: Gap update factor TS: Transmission Speed (Unit: bps)
Bus parameter	TTR	This setting value is the same as Minimum Slave Interval.
	HSA	Highest station address of the whole PROFIBUS Network
BFM #34 Bit 1		ON

**1.3.2 Applicable PLC**

For setting up a system, only one 64DP-M can be connected directly to the FX3U series PLC's extension port, or to any other extension unit / block's right side extension port.  
The 64DP-M occupies 8 points of I/O on the FX3U's expansion bus. The 8 points can be allocated from either inputs or outputs. The maximum I/O for a FX3U system is 256 I/O.

PLC Type	Version
FX3U series PLC	Ver. 2.21 or later

**Note**

When connecting two 64DP-M or more to FX3U PLC, a hardware error will occur in the FX3U PLC main unit (Error code: K6107).

1	Introduction
2	Specifications
3	Installation
4	Wiring
5	Mode Data Comms., Global Control
6	Allocation of Buffer Memories (BFMs)
7	Setting Parameters and Configuration
8	Example Program
9	Diagnostics

## 1.4 Communication Time

### 1.4.1 Communication Time

The communication time is the data exchange time between the FX3U series PLC and DP-Slaves. The expression below gives this communication time.

Communication time = Total PROFIBUS (bus) cycle time<sup>\*1</sup> for each DP-Slave + (2 × Scan time<sup>\*2</sup>)

- \*1. The PROFIBUS (bus) cycle time is a data update cycle time between the 64DP-M and DP-Slaves. The BFM #6 to #8 show the PROFIBUS (bus) cycle time.  
→ **To obtain the PROFIBUS (Bus) Cycle Time, refer to Subsection 1.4.2 and Section 6.8**
- \*2. D8010 to D 8012 show the scan time of the PLC.

#### Note

The PROFIBUS cycle time and FROM/TO instruction operates asynchronously. If data is written to the 64DP-M in the PROFIBUS cycle time, this data will move to the system area on the next PROFIBUS cycle time.

#### Reference

The FROM/TO Execution Time<sup>\*1</sup> varies as follows, depending on the data amount to be transferred.

- \*1. This table is also applicable to the other instructions accessing the 64DP-M BFMs.

#### FROM/TO Execution Time details

FNC No.	Instruction	Execution time in ON status (μs)		Execution time in OFF status (μs)		Note
		16-bit instruction	32-bit instruction	16-bit instruction	32-bit instruction	
FX3U-64DP-M						
78	FROM	15 + 275n	15 + 390n	0.585	1.105	BFM#350 to #1373
79	TO	15 + 345n	15 + 490n	0.585	1.105	BFM#2350 to #3373

n: The number of transferred data

#### Note

- The execution times above are approximate values for the FX3U-64DP-M.
- The FROM/TO Execution Time varies depending on each special function block.
- It is not necessary to check the all DP-Slaves' cyclic I/O data in a single PROFIBUS Cycle Time.



## 1.4.2 PROFIBUS (Bus) Cycle Time

The figure in the next page explains the PROFIBUS (bus) cycle time for one DP-master. In this example there are 3 slaves. The PROFIBUS (bus) cycle time needs to be as follows:

$$\text{PROFIBUS (bus) cycle time} = \text{the higher value of [MSI] or } \left[ \sum_{i=1}^{\text{Number of slaves}} \{ \text{Pt (DP-Slave (i))} + \text{Tsd}i \text{ (M)} \} + \text{Lr} \right]$$

→ The BFM#s #6 to #8 show the details on PROFIBUS (Bus) Cycle Time, refer to Section 6.8

Explanation of MSI, Pt (DP-Slave (i)), Treq (i), Max Tsd*r* (i), Tres (i), Tsd*i* (M), Lr see following table.

Wording	Description										
Pt (DP-Slave (i))	The polling time of the DP-Slave = Treq (i) + Max Tsd <i>r</i> (i) + Tres (i)										
Treq (i)	The request transmission time of the DP-Slave = {(number of output bytes to this DP-Slave + 9) × 11} / transmission speed										
Max tsd <i>r</i> (i)	Response time of the DP-slave = (This value is recorded in this DP-Slave GSD file) / transmission speed										
Tres (i)	Response transmission time of the DP-slave = {(Number of input bytes from this DP-Slave + 9) × 11} / transmission speed										
Tsd <i>i</i> (M)	Processing time of DP-master request/response = (This value from the following table) / transmission speed										
	<table border="1"> <thead> <tr> <th>Transmission Speed [bps]</th> <th>Value for Tsd<i>i</i> (M) calculation</th> </tr> </thead> <tbody> <tr> <td>9.6k</td> <td>10</td> </tr> <tr> <td>19.2k, 93.75k</td> <td>15</td> </tr> <tr> <td>187.5k, 500k</td> <td>80</td> </tr> <tr> <td>1.5M, 3M, 6M, 12M</td> <td>150</td> </tr> </tbody> </table>	Transmission Speed [bps]	Value for Tsd <i>i</i> (M) calculation	9.6k	10	19.2k, 93.75k	15	187.5k, 500k	80	1.5M, 3M, 6M, 12M	150
	Transmission Speed [bps]	Value for Tsd <i>i</i> (M) calculation									
	9.6k	10									
	19.2k, 93.75k	15									
187.5k, 500k	80										
1.5M, 3M, 6M, 12M	150										
Lr	Data refresh time = Max. 8 ms + 0.1 ms × number of DP-slaves										
MSI	Minimum slave interval is set in the configuration software (GX Configurator-DP).										

1

Introduction

2

Specifications

3

Installation

4

Wiring

5

Mode-  
Data Comms.,  
Global Control

6

Allocation of  
Buffer Memories  
(BFMs)

7

Setting  
Parameters and  
Configuration

8

Example  
Program

9

Diagnostics

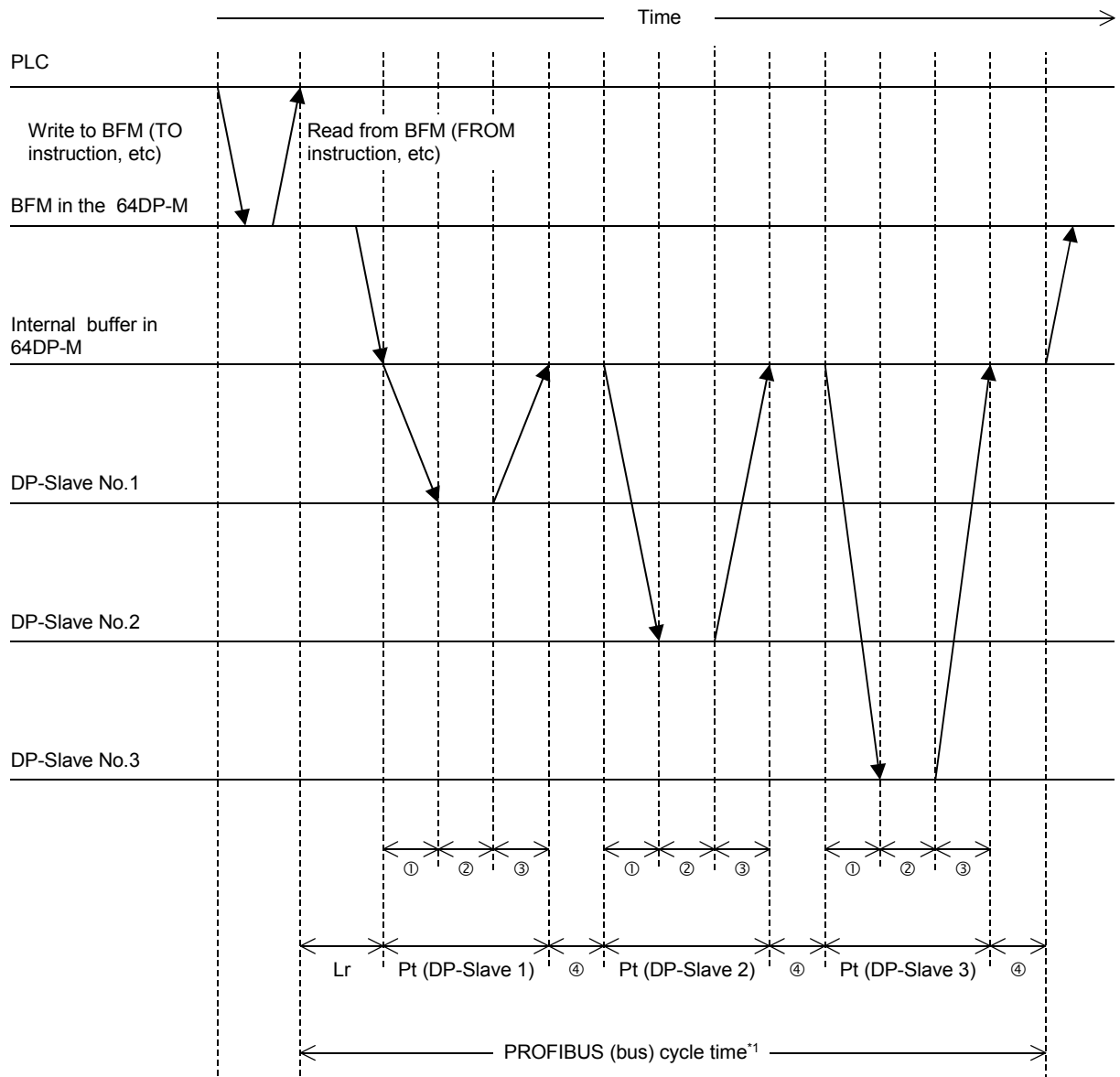

- ① This time is "Treq" for each DP-slave.
- ② This time is "Maximum Tsdr" for each DP-slave.
- ③ This time is "Tres" for each DP-slave.
- ④ This time is Tsd(M)

\*1. The PROFIBUS Cycle Time needs to be the larger value obtained from the expression in the previous page, or the MSI. The MSI (Minimum Slave Interval) is the value set by GX Configurator-DP.

**Note**

The instructions to access BFMs (FROM/TO instruction, etc.) and the PROFIBUS (bus) cycle are asynchronous. BFM #6 shows the precise cycle time to exchange data after the dwell time expires.

→ For details on the PROFIBUS (Bus) Cycle Time BFM #6 to #8, refer to Section 6.8

**Reference**

The PROFIBUS (bus) Cycle Time variance depends primarily on the number of DP-Slaves and the number of I/O data bytes.

**PROFIBUS Cycle Time measurement**

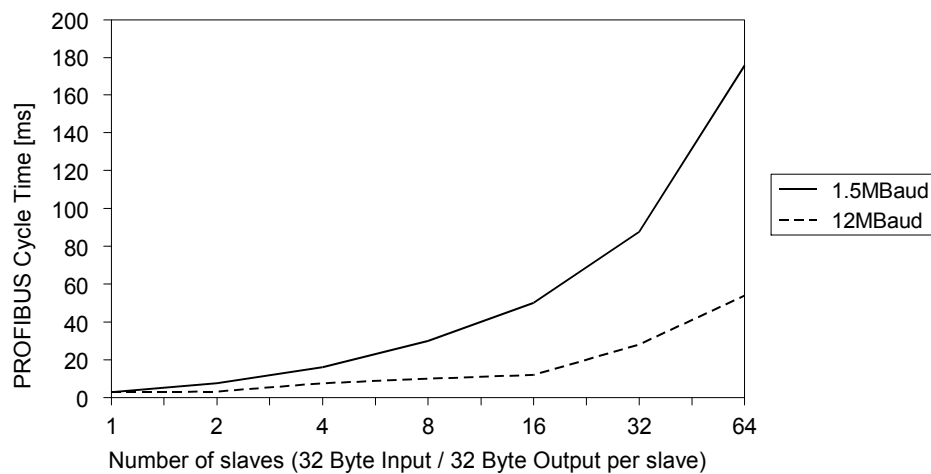

<b>1</b>	Introduction
<b>2</b>	Specifications
<b>3</b>	Installation
<b>4</b>	Wiring
<b>5</b>	Mode-Data Comms., Global Control
<b>6</b>	Allocation of Buffer Memories (BF-Ms)
<b>7</b>	Setting Parameters and Configuration
<b>8</b>	Example Program
<b>9</b>	Diagnostics

## 1.5 System Start-up Procedure

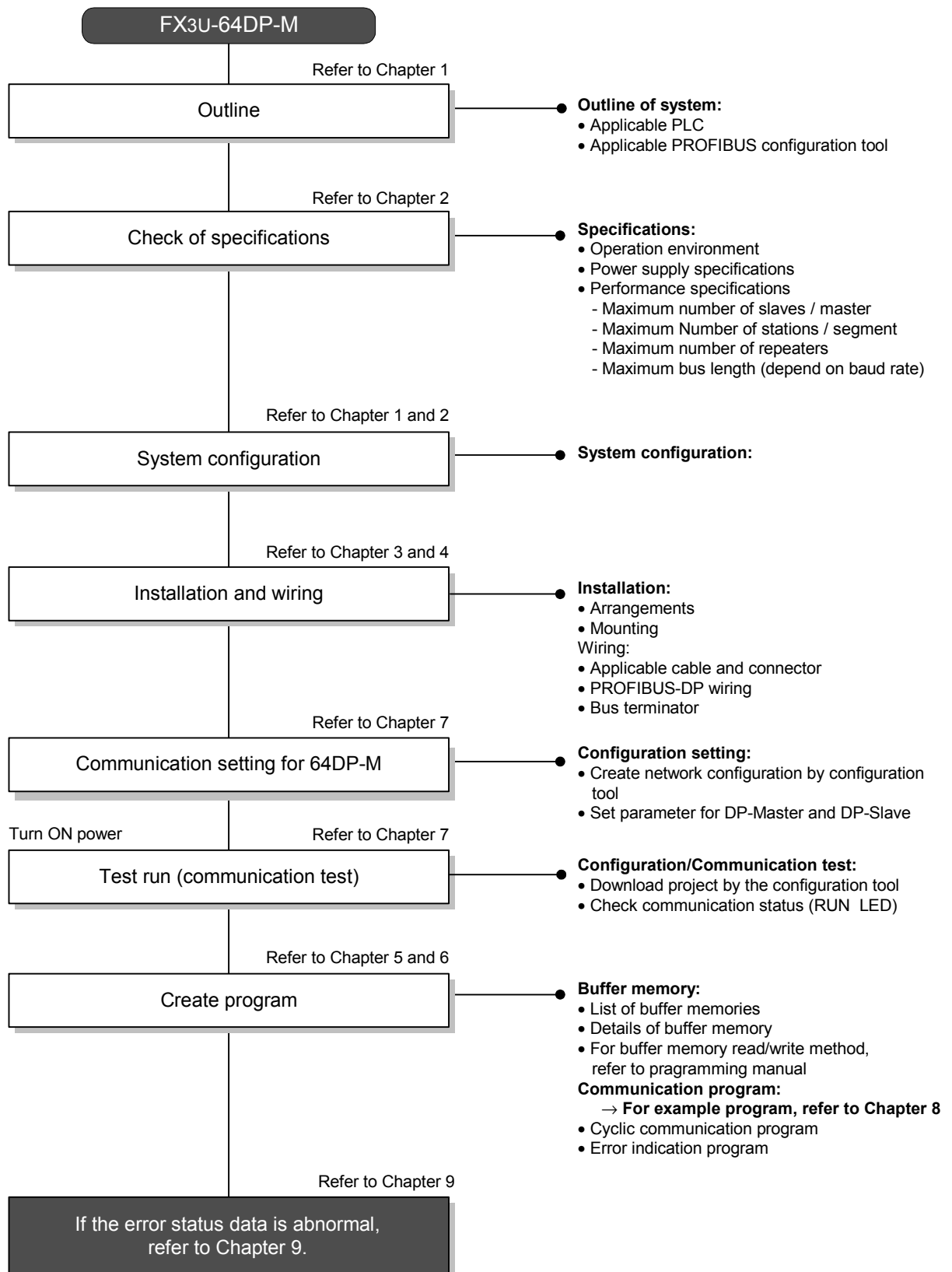

## 2. Specifications

### DESIGN PRECAUTIONS



- Make sure to have the following safety circuits outside of the PLC to ensure safe system operation even during external power supply problems or PLC failure. Otherwise, malfunctions may cause serious accidents.
  - 1) An emergency stop circuit, a protection circuit, an interlock circuit for opposite movements, such as normal and reverse rotations, and an interlock circuit for preventing damage to the machine at the upper and lower positioning limits should be configured on the outside of the PLC.
  - 2) Note that when the PLC CPU detects an error, such as a watchdog timer error, during self-diagnosis, all outputs are turned off. Also, when an error that cannot be detected by the PLC CPU occurs in an input/output control block, output control may be disabled. Design external circuits and mechanisms to ensure safe operations of the machine in such a case.
  - 3) Note that when some sort of error occurs in a relay, triac or transistor of the output unit/block, output may be kept on or off. For output signals that may lead to serious accidents, design external circuits and mechanisms to ensure safe operations of the machine.

### DESIGN PRECAUTIONS



- Make sure to observe the precautions below to prevent damages to the system due to the abnormal data writing by noise to the PLC:
  - 1) Do not bundle the control line together with or lay it close to the main circuit or power line. As a guideline, lay the control line at least 100mm (3.94") or more away from the main circuit or power line. Noise may cause malfunctions.
  - 2) Ground the shield wire with the PLC. Do not ground together with high voltage lines.
- Install module so that excessive force will not be applied to peripheral device connectors. Failure to do so may result in wire damage/breakage or PLC failure.

### STARTUP AND MAINTENANCE PRECAUTIONS



- Do not touch any terminal while the PLC's power is on. Doing so may cause electric shock or malfunctions.
- Before cleaning or retightening terminals, externally cut off all phases of the power supply. Failure to do so may cause electric shock.
- Before modifying or disrupting the program in operation or running the PLC, carefully read through this manual and the associated manuals and ensure the safety of the operation. An operation error may damage the machinery or cause accidents.

### STARTUP AND MAINTENANCE PRECAUTIONS



- Do not disassemble or modify the unit. Doing so may cause fire, equipment failures, or malfunctions. \* For repair, contact your local Mitsubishi Electric distributor.
- Do not drop the product and exert strong impact. Doing so may cause damage.
- Turn off the power to the PLC before attaching or detaching the peripheral devices. Failure to do so may cause equipment failures or malfunctions.

1

Introduction

2

Specifications

3

Installation

4

Wiring

5

Mode-Data Comms., Global Control

6

Allocation of Buffer Memories (BF-Ms)

7

Setting Parameters and Configuration

8

Example Program

9

Diagnostics

**DISPOSAL PRECAUTIONS**



- Please contact a certified electronic waste disposal company for the environmentally safe recycling and disposal of your device.

**TRANSPORT AND STORAGE PRECAUTIONS**



- The PLC is a precision instrument. During transportation, avoid impacts. After transportation, verify the operations of the products.

## 2.1 General Specifications

For the general specification, refer to the manual of the PLC main unit.  
The items other than the following are equivalent to those of the PLC main unit.  
However, please don't perform any dielectric withstand voltage tests and insulation resistance tests to this product.

→ Refer to FX3U PLC Hardware Edition

Item	Specifications	
Withstand voltage	500 V AC for 1 min	Conformance to JEM-1021
Insulation resistance	5 MΩ or more by 500 V DC Megger	Between communication connector frame and ground terminal of PLC main unit

## 2.2 Power Supply Specifications

Items	Description
Internal Power Supply	155 mA at 24V DC is supplied from the internal power supply (service power supply) in main unit via extension cable.

## 2.3 Performance Specifications

Item		Specifications	
Transmission Type		Bus network	
Unit Type		PROFIBUS-DP master Class 1	
Transmission Data (Maximum Exchanged Data Length)		Normal service mode: 32 byte/slave Extended service mode (default): 244 byte/slave	
Maximum Number of FX3u-64DP-M at one PLC		1 unit	
Maximum Number of FX3u-64DP-M at one PROFIBUS-DP Network		3 units In case of multi master configuration, all master stations must be FX3u-64DP-M.	
Maximum Number of Repeaters / Communication Path		3 units	
Maximum Number of Stations / Segment		32 stations	
Maximum Number of Slaves / Master		64 slaves	
No. of Connectable Nodes		31, 61 (1), 91 (2), 121 (3)	
Supported Transmission Speed (bps) and Bus Length	9.6k, 19.2k, 93.75k	1,200 m (3,937') / segment	→ Refer to Note 1
	187.5k	1,000 m (3,281') / segment	
	500k	400 m (1,312') / segment	
	1.5 M	200 m (656') / segment	
	3M, 6M, 12M	100 m (328') / segment	
PNO ID		"F364" hex	
Connector	PROFIBUS-DP Network	Port for PROFIBUS-DP network (9 pin D-SUB Connector)	
Global Control		Synchronization, unsynchronization, freeze and unfreeze modes are supported.	
Terminal Resistor		Not built in.	
Number of occupied I/O points		8 points taken from the PLC extension bus (can be either input or output)	
Applicable PLC		FX3U Series PLC	
LED indicators	POWER LED	Lit when 24V DC power is supplied from the PLC or external power supply. → For other LED status, refer to Section 9.1	
	RUN LED	Lit: During normal operation → For other LED status, refer to Section 9.1	
	FROM/TO LED	Lit when a FROM/TO instruction from the PLC is in operation.	
	TOKEN LED	Lit when token is maintained.	
	ERROR LED	Unlit: During normal operation. → For other LED status, refer to Section 9.1 and 9.2	

### Note 1

Length that the bus can be expanded by using repeaters.

Maximum Bus Length = (No. of repeaters + 1) × (Bus Length / segment)

Transmission Speed (bps)	Maximum Bus Length			
	No repeater	1 repeater	2 repeaters	3 repeaters
9.6k, 19.2k, 93.75k	1,200 m (3,937')	2,400 m (7,874')	3,600 m (11,811')	4,800 m (15,748')
187.5k	1,000 m (3,281')	2,000 m (6,562')	3,000 (9,843')	4,000 m (13,123')
500k	400 m (1,312')	800 m (2,625')	1,200 m (3,937')	1,600 m (5,249')
1.5 M	200 m (656')	400 m (1,312')	600 m (1,969')	800 m (2,625')
3M, 6M, 12M	100 m (328')	200 m (656')	300 m (984')	400 m (1,312')

1

Introduction

2

Specifications

3

Installation

4

Wiring

5

Mode-  
Data Comms.,  
Global Control

6

Allocation of  
Buffer Memories  
(BFMs)

7

Setting  
Parameters and  
Configuration

8

Example  
Program

9

Diagnostics

## 3. Installation

### DESIGN PRECAUTIONS



## DANGER

- Make sure to have the following safety circuits outside of the PLC to ensure safe system operation even during external power supply problems or PLC failure.  
Otherwise, malfunctions may cause serious accidents.
  - 1) An emergency stop circuit, a protection circuit, an interlock circuit for opposite movements, such as normal and reverse rotations, and an interlock circuit for preventing damage to the machine at the upper and lower positioning limits should be configured on the outside of the PLC.
  - 2) Note that when the PLC CPU detects an error, such as a watchdog timer error, during self-diagnosis, all outputs are turned off. Also, when an error that cannot be detected by the PLC CPU occurs in an input/output control block, output control may be disabled.  
Design external circuits and mechanisms to ensure safe operations of the machine in such a case.
  - 3) Note that when some sort of error occurs in a relay, triac or transistor of the output unit/block, output may be kept on or off.  
For output signals that may lead to serious accidents, design external circuits and mechanisms to ensure safe operations of the machine.

### DESIGN PRECAUTIONS



## CAUTION

- Make sure to observe the precautions below to prevent damages to the system due to the abnormal data writing by noise to the PLC:
  - 1) Do not bundle the control line together with or lay it close to the main circuit or power line. As a guideline, lay the control line at least 100mm (3.94") or more away from the main circuit or power line. Noise may cause malfunctions.
  - 2) Ground the shield wire with the PLC. Do not ground together with high voltage lines.
- Install module so that excessive force will not be applied to peripheral device connectors. Failure to do so may result in wire damage/breakage or PLC failure.

### INSTALLATION PRECAUTIONS



## DANGER

- Make sure to cut off all phases of the power supply externally before attempting installation or wiring work.  
Failure to do so may cause electric shock.



**INSTALLATION PRECAUTIONS**



**CAUTION**

- Use the product within the generic environment specifications described in the PLC main unit manual (Hardware Edition).  
Never use the product in areas with dust, oily smoke, conductive dusts, corrosive gas (salt air, Cl<sub>2</sub>, H<sub>2</sub>S, SO<sub>2</sub>, or NO<sub>2</sub>), flammable gas, vibration or impacts, or exposed to high temperature, condensation, or wind and rain. If the product is used in such conditions, electric shock, fire, malfunction, deterioration or damage may occur.
- Install the product securely using a DIN rail or mounting screws.
- Install the product on a flat surface.  
If the mounting surface is rough, undue force will be applied to the PC board, thereby causing nonconformities.
- When drilling screw holes or wiring, make sure cutting or wire debris does not enter the ventilation slits. Failure to do so may cause fire, equipment failures or malfunctions.
- Be sure to remove the dust proof sheet from the PLC's ventilation port when the installation work is completed. Failure to do so may cause fires, equipment failures, and malfunctions.
- Connect the extension and communication cables securely to their designated connectors. Unsecured connection may cause malfunctions.
- Do not touch the conductive parts of the product directly to avoid failure or malfunction.

1

Introduction

2

Specifications

3

Installation

4

Wiring

5

Mode-  
Data Comms.,  
Global Control

6

Allocation of  
Buffer Memories  
(BF-Ms)

7

Setting  
Parameters and  
Configuration

8

Example  
Program

9

Diagnostics

### 3.1 Arrangements

The 64DP-M connects on the right side of an FX3U series main unit or extension units/blocks (including special function units/blocks).

However, PLC can connect extension equipment to both the right and left-hand sides. When planning to add additional extension equipment in the future, please keep the appropriate space available on both sides of the main unit.

For further information of installation arrangements, refer to the following manual.

→ **FX3U PLC Hardware Edition**

#### Note

- Keep a space of 50 mm (1.97") or more between the unit main body and other devices and structures. Install the unit as far from high-voltage lines, high-voltage devices and power equipment as possible.

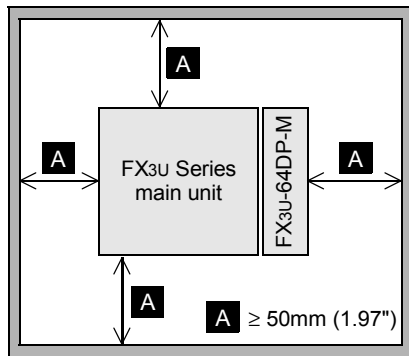

- To prevent temperature rise, do not install the PLC on a floor or a ceiling or in the vertical direction. Install it horizontally on a wall as shown below.

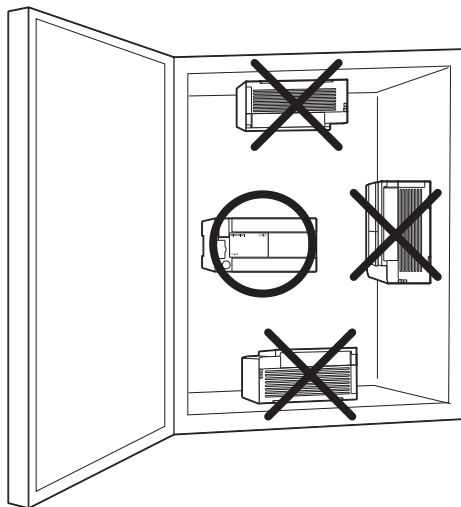

- Arrange the extension cable in such a way that the left connectors of the I/O extension units/blocks or special extension units/blocks are connected on the side closer to the main unit.

## 3.2 Mounting

The 64DP-M can be mounted on a DIN rail (DIN46227) or mounted directly using screws.

### 3.2.1 Direct Mounting

The 64DP-M can be mounted with M4 screws by using the direct mounting holes. The 64DP-M mounting hole pitches are shown below.

→ For details, refer to FX3U PLC Hardware Edition

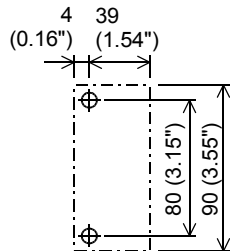

#### Point

- Mounting screw: M4 screw.
- An interval space between each unit of 1 to 2 mm (0.04" to 0.08") is necessary.
- Mount the main unit, I/O extension units/blocks, and special function units/blocks which are installed on the left side of 64DP-M first.

#### Direct Mounting Procedure

- 1) Make mounting holes in the mounting surface referring to the above diagram.
- 2) Fit the 64DP-M (right fig. A) based on the holes, and secure it with M4 screws (right fig. B).

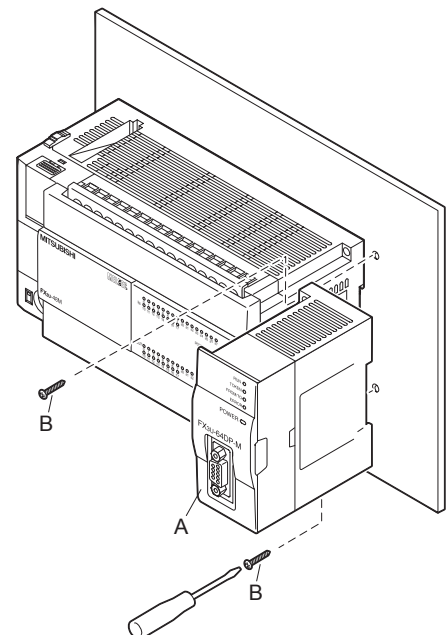

- 3) Connect extension cable (right fig. C) to the main unit, I/O extension unit/block, or special function unit/block to the left side.

→ For extension cable connection procedure, refer to FX3U PLC Hardware Edition

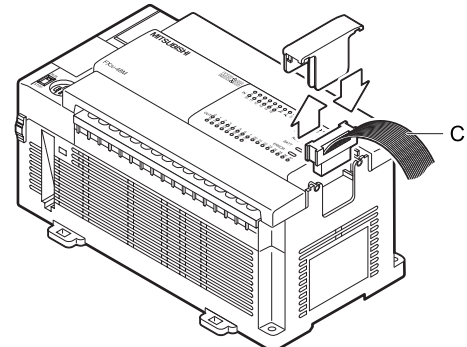

1

Introduction

2

Specifications

3

Installation

4

Wiring

5

Mode-Data Comms., Global Control

6

Allocation of Buffer Memories (BF-Ms)

7

Setting Parameters and Configuration

8

Example Program

9

Diagnostics

### 3.2.2 DIN Rail Mounting

The 64DP-M can be mounted on a DIN rail (DIN46227, 35mm width).

→ For details, refer to FX3U PLC Hardware Edition

#### Note

- DIN rail uses DIN 46227 (35mm width).
- An interval space between each unit of 1 to 2 mm (0.04" to 0.08") is necessary.
- Mount the main unit, I/O extension units/blocks, and special function units/blocks which are installed in the left side of 64DP-M first.

#### DIN Rail Mounting Procedure

- 1) Fit the upper edge of the DIN rail mounting groove (right fig. A) onto the DIN rail.
- 2) Push the product onto the DIN rail.

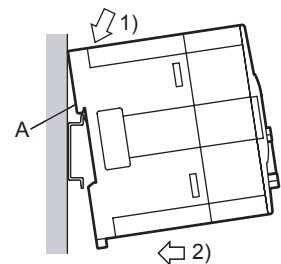

- 3) Connect extension cable (right fig.B) to the main unit, I/O extension unit/block, or special function unit/block to the left side.

→ For extension cable connection procedure, refer to FX3U PLC Hardware Edition

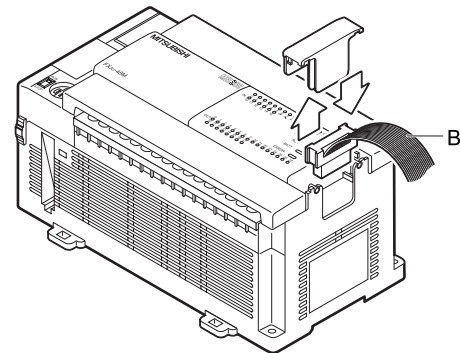

#### Removing Procedure from DIN Rail

- 1) Disconnect the PROFIBUS-DP communication cable and extension cables.
- 2) Insert the tip of a screwdriver into the hole of the DIN rail mounting hook (right fig. A).
- 3) Using a screwdriver as shown in the figure to the right, the DIN rail mounting hook (right fig. A) is pulled out.
- 4) Remove the product from the DIN rail (right fig. B).

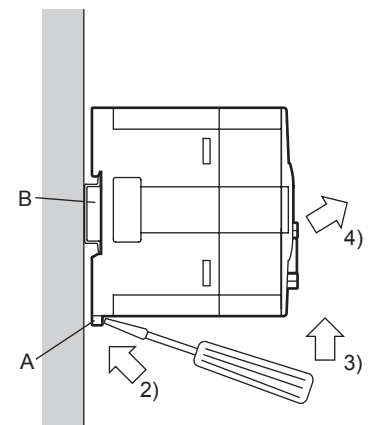

## 4. Wiring

### DESIGN PRECAUTIONS



### CAUTION

- Make sure to observe the precautions below to prevent damages to the system due to the abnormal data writing by noise to the PLC:
  - 1) Do not bundle the control line together with or lay it close to the main circuit or power line. As a guideline, lay the control line at least 100mm (3.94") or more away from the main circuit or power line. Noise may cause malfunctions.
  - 2) Ground the shield wire with the PLC. Do not ground together with high voltage lines.
- Install module so that excessive force will not be applied to peripheral device connectors. Failure to do so may result in wire damage/breakage or PLC failure.

### WIRING PRECAUTIONS



### DANGER

- Cut off all phases of the power supply externally before installation or wiring work in order to avoid damage to the product or electric shock.

### WIRING PRECAUTIONS



### CAUTION

- When drilling screw holes or wiring, make sure cutting or wire debris does not enter the ventilation slits. Failure to do so may cause fire, equipment failures or malfunctions.

### 4.1 Applicable Cable and Connector

The following table shows the applicable cable and connector for a PROFIBUS-DP network.

Item	Description
PROFIBUS-DP network cable	Shielded twisted-pair PROFIBUS cable complying with EN50170
Connector	Applicable only to PROFIBUS connector (9-pin D-SUB Connector: #4-40unc inch screw thread) → <b>For PROFIBUS connectors, see the PROFIBUS connector manual</b>

1

Introduction

2

Specifications

3

Installation

4

Wiring

5

Mode-Data Comms., Global Control

6

Allocation of Buffer Memories (BF-Ms)

7

Setting Parameters and Configuration

8

Example Program

9

Diagnostics

## 4.2 PROFIBUS-DP Wiring

To connect the 64DP-M to a PROFIBUS-DP network, use only the PROFIBUS connector and shielded twisted-pair PROFIBUS cable complying with EN50170.

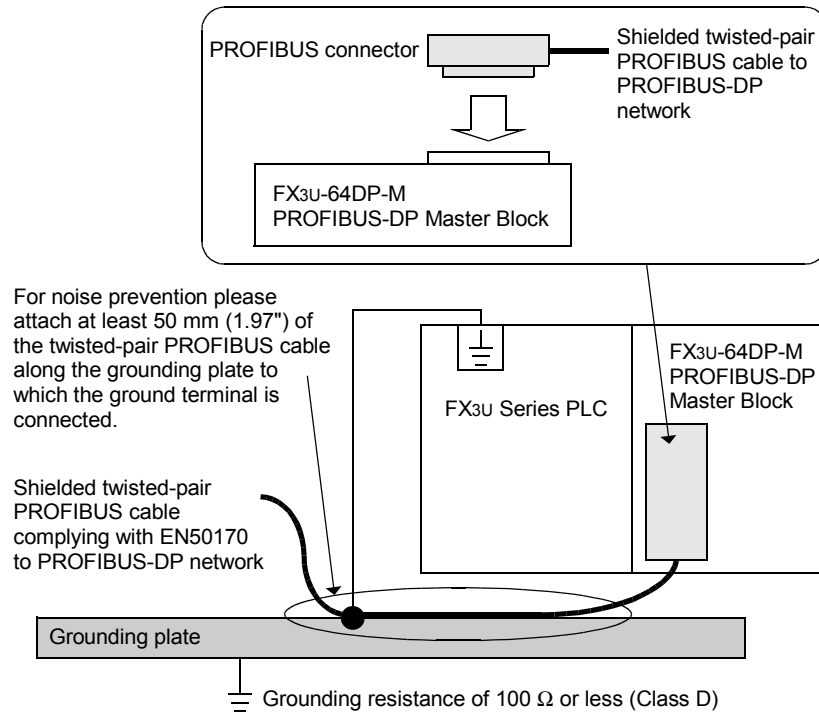

## 4.3 Grounding

Grounding should be performed as stated below.

- The grounding resistance should be 100 $\Omega$  or less.
- Independent grounding should be performed for best results. When independent grounding is not performed, perform "shared grounding" of the following figure.

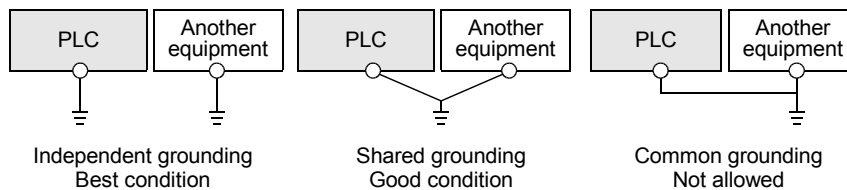

- The grounding wire size should be AWG 14 (2 mm<sup>2</sup>) or larger.
- The grounding point should be close to the PLC, and all grounding wire should be as short as possible.

## 4.4 Bus Terminator

The units at each end of the PROFIBUS-DP network must have a bus terminator. This will either be in the DP-Master or DP-Slave unit or in the PROFIBUS connector.

However, the 64DP-M does not have a terminating resistance built-in.

## 5. Mode, Data Communication, Global Control

### 5.1 Cyclic I/O Data Communication

Cyclic I/O Data Communication is used for periodic data communication (e.g. I/O, analog input value, etc.) between 64DP-M and DP-Slaves. The 64DP-M can exchange data to DP-Slaves without using the Data Consistency Mode in cyclic I/O data communication when I/O data is 16 bit or less.

However, the 64DP-M has to use the Data Consistency Mode to exchange data to DP-Slaves when I/O data is more than 16 bit. Therefore, it shows by Cyclic I/O Data Consistency Activate/Deactivate flags in BFM #84 to #87 and #92 to #95 whether Data Consistency Mode is necessary or not. This flag is set by each DP-Slave Parameter Setting on GX Configurator-DP. (Depending on the DP-Slave, it may be set up automatically.)

- For allocation of flags, refer to Section 6.4, 6.23, and 6.24
- For details on Cyclic Input Data Area, refer to Section 6.23
- For details on Cyclic Output Data Area, refer to Section 6.24

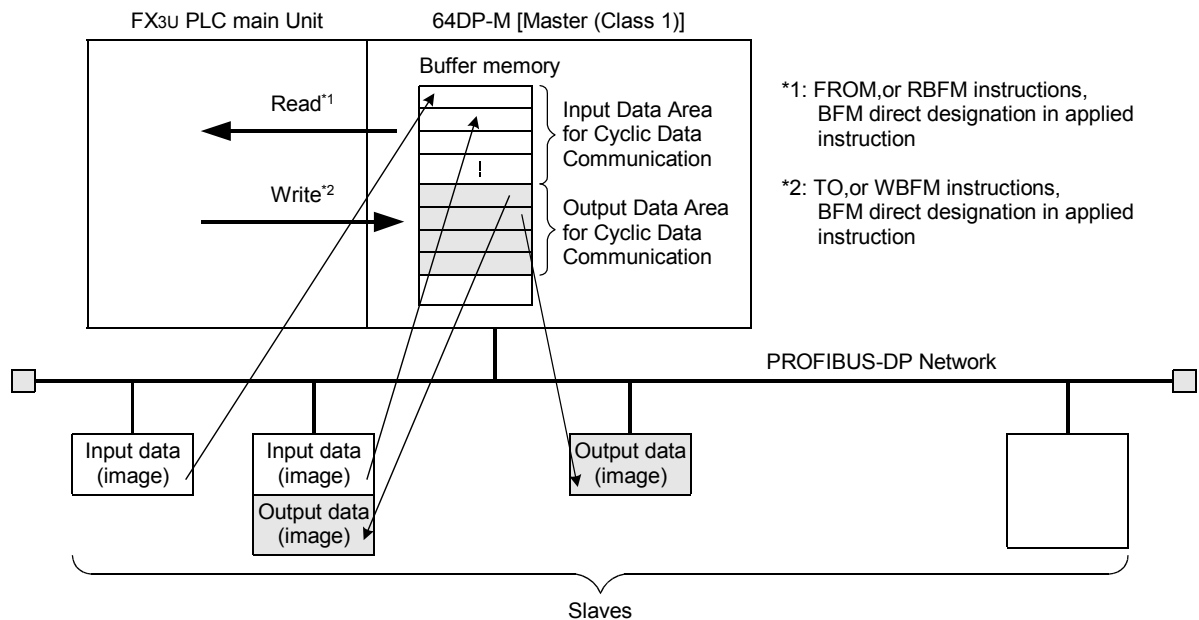

#### 5.1.1 Mode in Cyclic I/O Data Communication

The 64DP-M has Normal Service Mode (mode 0) and Extended Service Mode (mode 3) in cyclic I/O data communication, decided by BFM #39. In cyclic I/O data communication, the maximum exchanged data length to DP-Slave is decided by this mode setting.

For the maximum exchanged data length, refer to the following table. Moreover, the mode setting can be checked by value in BFM #39.

→ For mode setting [BFM #39], refer to Section 6.21

BFM #39 Value	Setting Mode	Maximum Exchanged Data Length
K0	Normal Service Mode (mode 0)	Maximum 32 byte/slave 64DP-M can exchange 32 bytes (16 words) of cyclic I/O data to every DP-Slave.
K3	Extended Service Mode (mode 3)	Maximum 244 byte/slave 64DP-M can exchange 0 to 244 bytes of cyclic I/O data to each DP-Slave. However, the total cyclic I/O data for all the DP-Slaves has a maximum of 2048/2048 bytes.

- 1 Introduction
- 2 Specifications
- 3 Installation
- 4 Wiring
- 5 Mode, Data Comms., Global Control
- 6 Allocation of Buffer Memories (BFMs)
- 7 Setting Parameters and Configuration
- 8 Example Program
- 9 Diagnostics

### 5.1.2 Normal Service Mode (Mode 0)

64DP-M can exchange 32 bytes (16 words) of cyclic I/O data to every DP-Slave as follows.

- For Cyclic Input Data Area, refer to Section 6.23
- For Cyclic Output Data Area, refer to Section 6.24

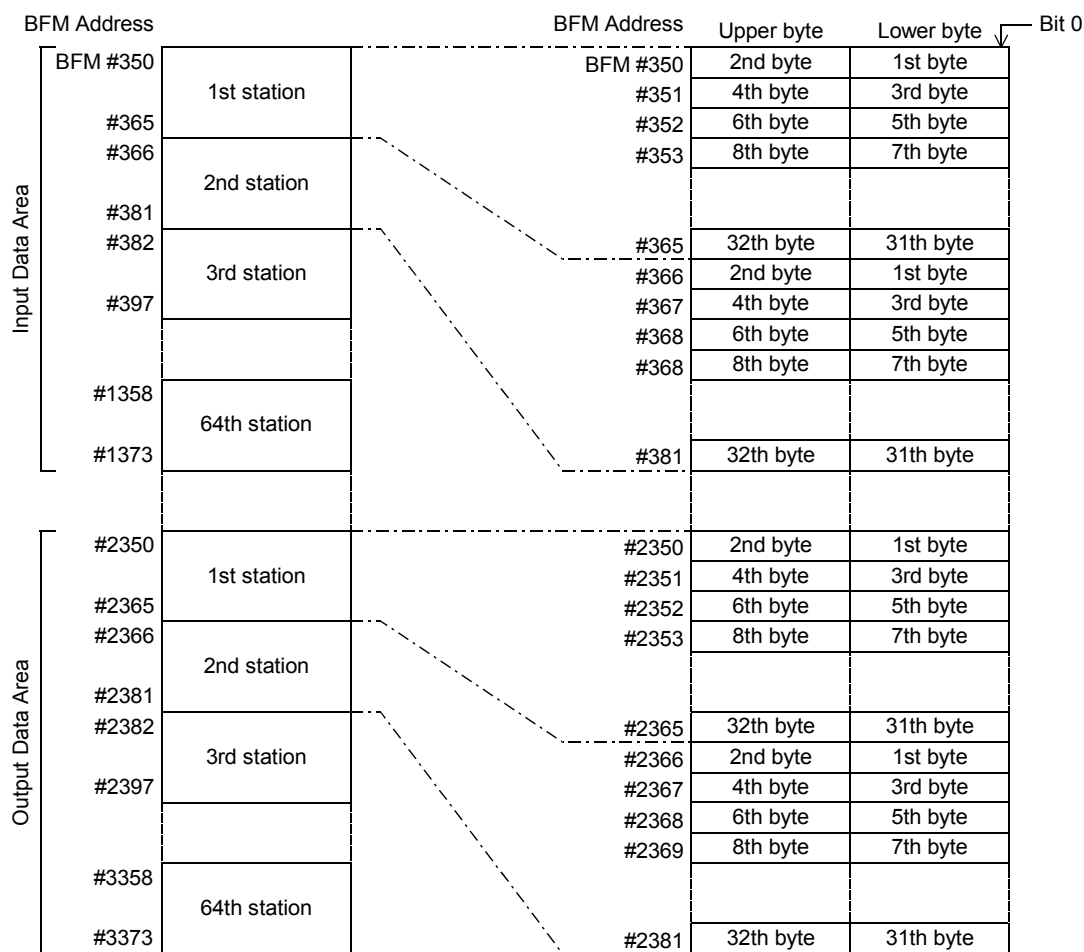



### 5.1.3 Extended Service Mode (Mode 3)

64DP-M can exchange 0 to 244 bytes of I/O data to each DP-Slave. The I/O data length of each DP-Slave is assigned according to the parameter file set in the GX Configurator-DP.

However, total I/O data for all the DP-Slaves has a maximum of 2048/2048 bytes.

→ For Cyclic Input Data Area, refer to Section 6.23

→ For Cyclic Output Data Area, refer to Section 6.24

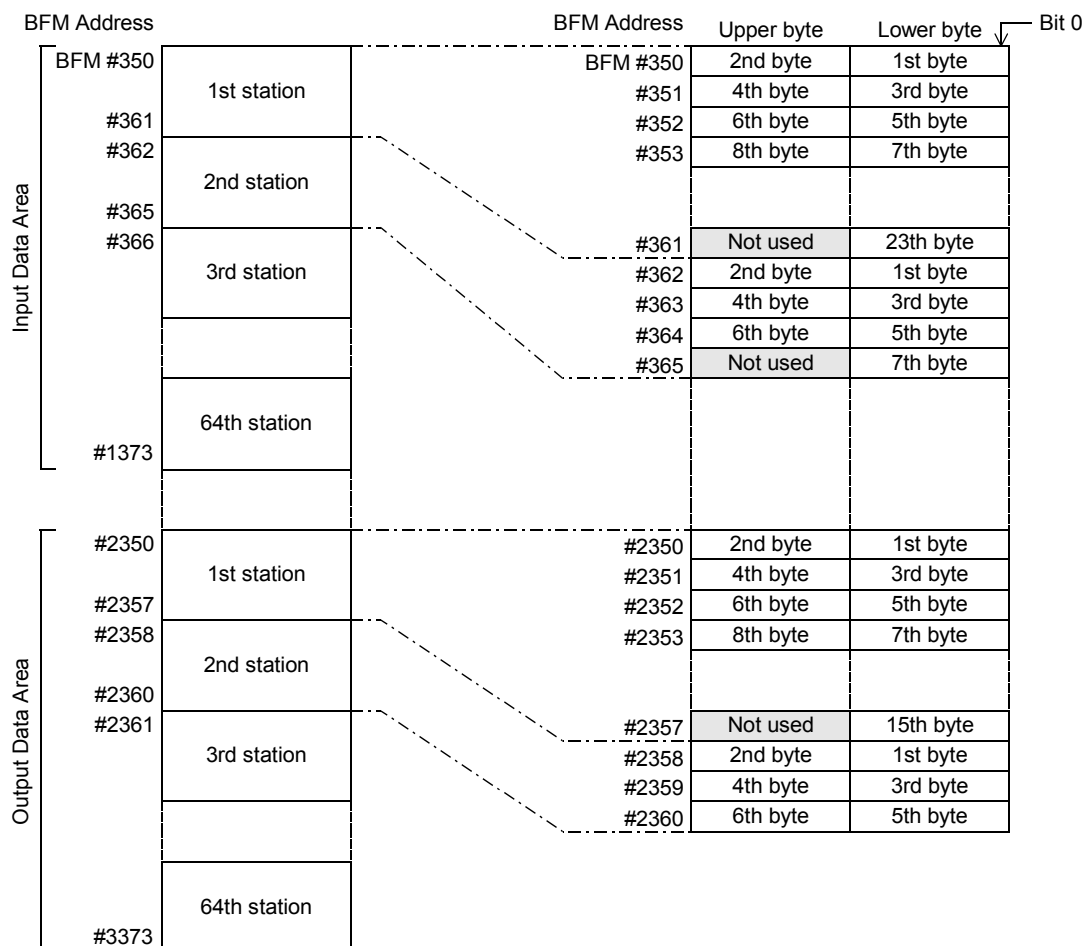

1	Introduction
2	Specifications
3	Installation
4	Wiring
5	Mode-Data Comms., Global Control
6	Allocation of Buffer Memories (BFMs)
7	Setting Parameters and Configuration
8	Example Program
9	Diagnostics

## 5.2 Acyclic I/O Data Communication

The acyclic communication can be used for setting and change the DP-Slave parameter during cyclic communication. The I/O data channel consists of 244 byte. Acyclic data communication has lower communicative priority than cyclic data communication.

The 64DP-M has 4 data areas for each acyclic I/O communication.

- For allocation of flags, refer to Section 6.4, 6.9, 6.25, and 6.26
- For details on Acyclic Input Data Area, refer to Section 6.25
- For details on Acyclic Output Data Area, refer to Section 6.26

### Point

Acyclic I/O Data Communication can only be used in RUN (BFM #0 = K1), Clear (BFM #0 = K3) or AutoClear (BFM #0 = K4) mode.

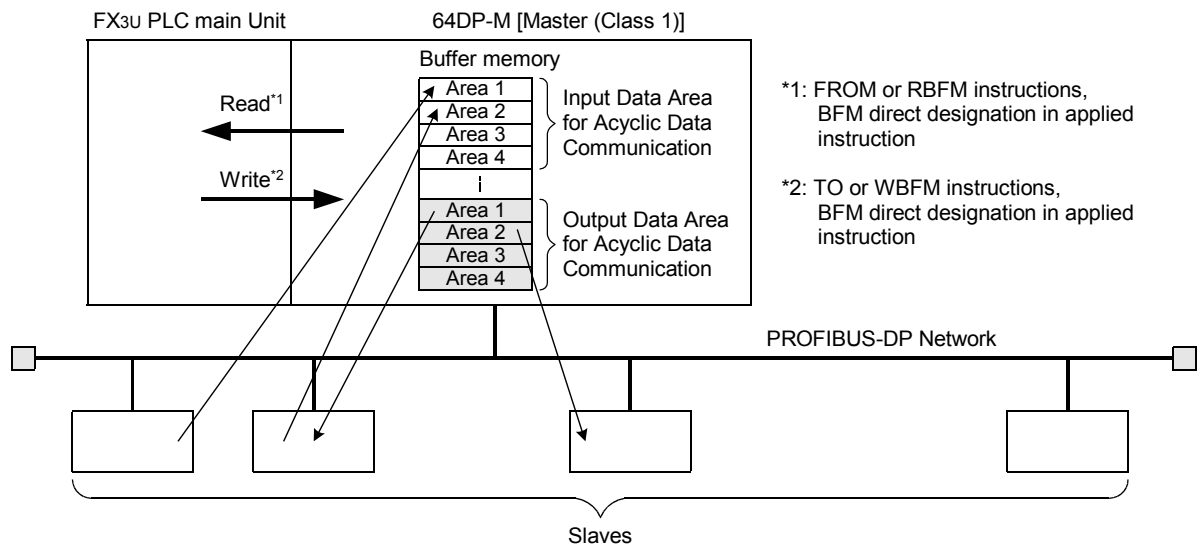

## 5.3 Diagnostic Information

### 5.3.1 Slave Diagnostic

The 64DP-M can stack the Slave Diagnostic Information to a maximum of 64 entries in the Internal Diagnostic FIFO Area for all DP-Slaves. Moreover, 64DP-M can read the current Slave Diagnostic Information from a single specified DP-Slave.

#### 1. Direct read the current Slave Diagnostic Information

The 64DP-M can directly read the current Slave Diagnostic Information from the selected DP-Slave by BFM #7209, BFM #7210 to #7335.

→ For allocation of flags, refer to Section 6.4, 6.13, and 6.29

→ For details on Slave Diagnostic Information Data, refer to Section 6.29

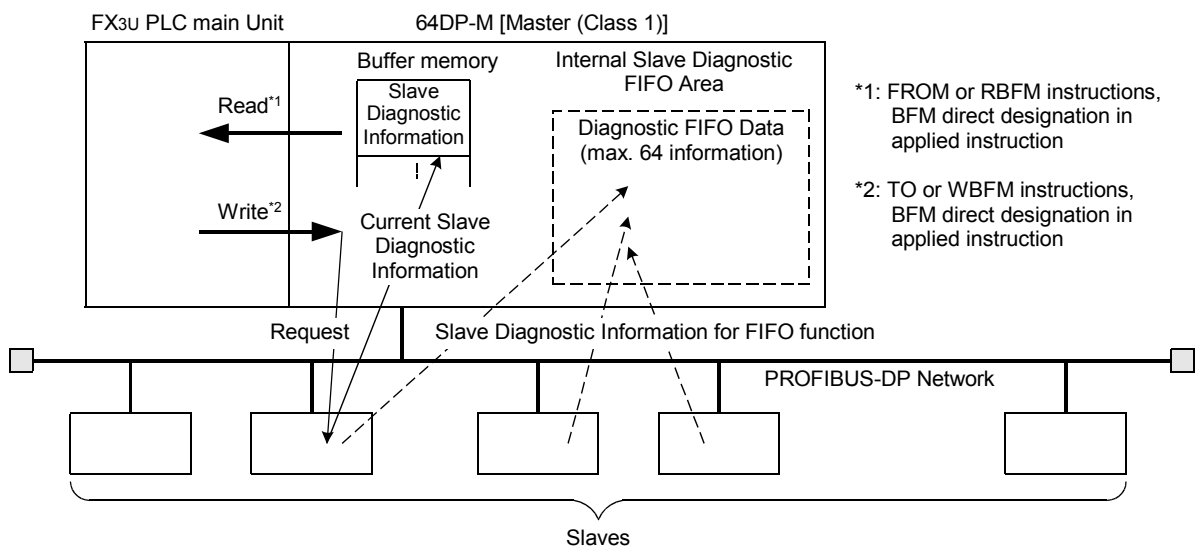

#### Point

This function can only be used in RUN (BFM #0 = K1), Clear (BFM #0 = K3) or AutoClear (BFM #0 = K4) mode.

#### 2. Slave Diagnostic FIFO (History)

The 64DP-M can stack the Slave Diagnostic Information to a maximum of 64 entries in the Internal Diagnostic FIFO Area for all DP-Slaves. The Slave Diagnostic Information, which enters this Internal Diagnostic FIFO Area can be read (stored) in BFM #7338 to #7463 as history by the FIFO function.

Moreover, after stocking up to 64 Slave Diagnostic Information in Internal Diagnostic FIFO Area, the new Slave Diagnostic Information is not stocked (will be ignored).

→ For allocation of flags, refer to Section 6.4, 6.13, and 6.30

→ For details on Slave Diagnostic Information FIFO, refer to Section 6.30

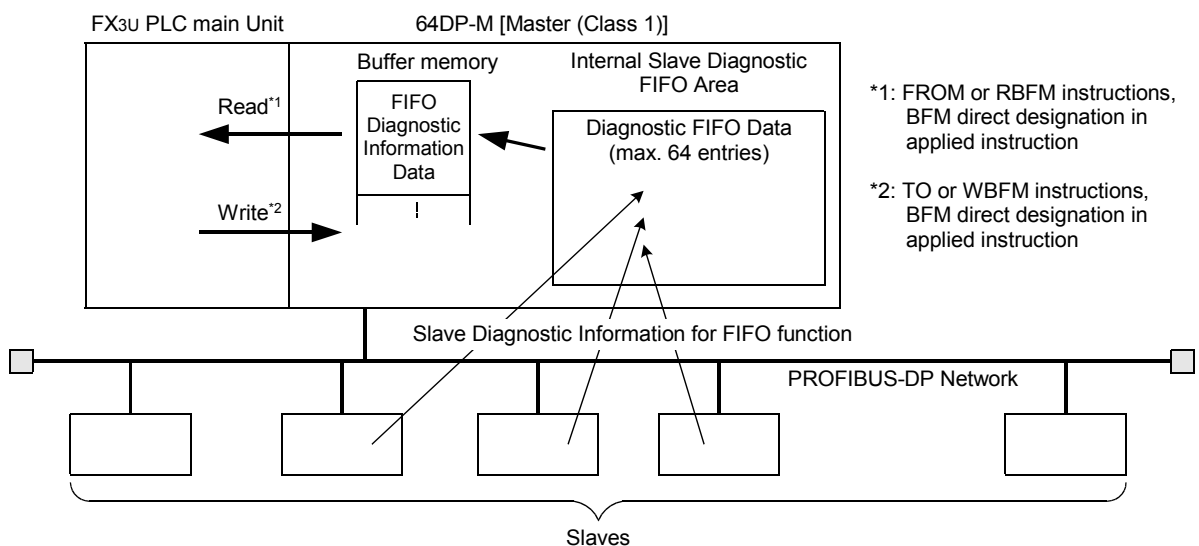

1	Introduction
2	Specifications
3	Installation
4	Wiring
5	Mode-Data Comms., Global Control
6	Allocation of Buffer Memories (BFMs)
7	Setting Parameters and Configuration
8	Example Program
9	Diagnostics

### 5.3.2 Alarm Message

The 64DP-M can handle Alarm Messages from the PROFIBUS-DPV1 slaves (alarm model). When receiving an Alarm Message from the DP-Slave, 64DP-M should acknowledge receiving from the DP-Slave. If 64DP-M does not acknowledge, the DP-Slave can not send a new alarm message.

**Note**

This function can only be used in RUN (BFM #0 = K1), Clear (BFM #0 = K3) or AutoClear (BFM #0 = K4) mode.  
 → For allocation of flags, refer to Section 6.4, 6.13, and 6.32  
 → For details on Alarm Message, refer to Section 6.32

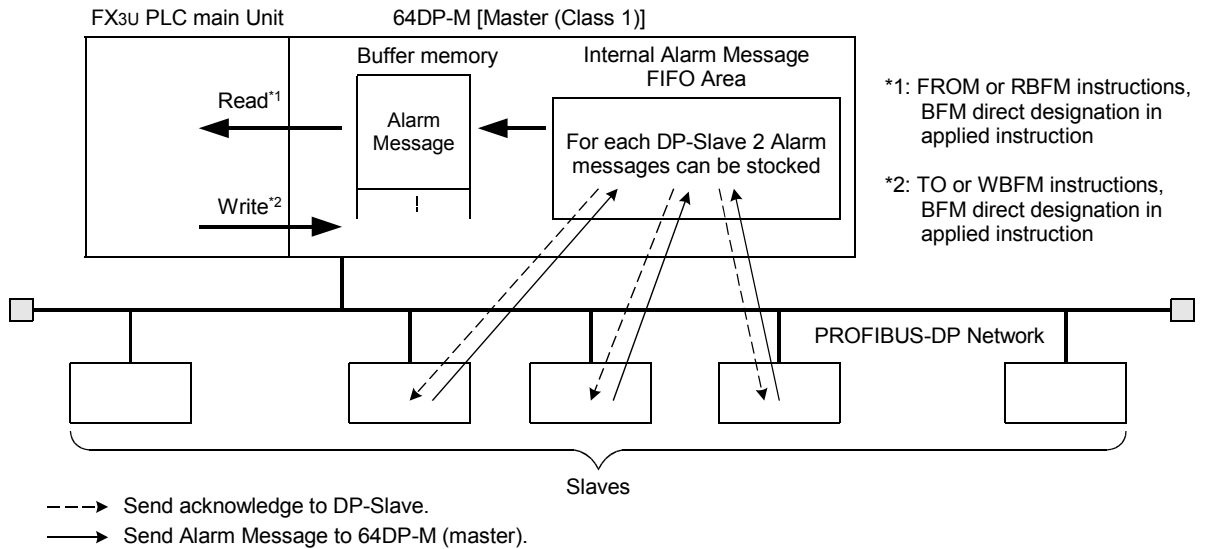

### 5.4 Global Control

The 64DP-M supports SYNC/UNSYNC and FREEZE/UNFREEZE Global Control Service. The 64DP-M is normally set as UNSYNC and UNFREEZE in Global Control Mode.

→ For allocation of setting error flags, refer to Section 6.12  
 → For details on Global Control Area, refer to Section 6.34

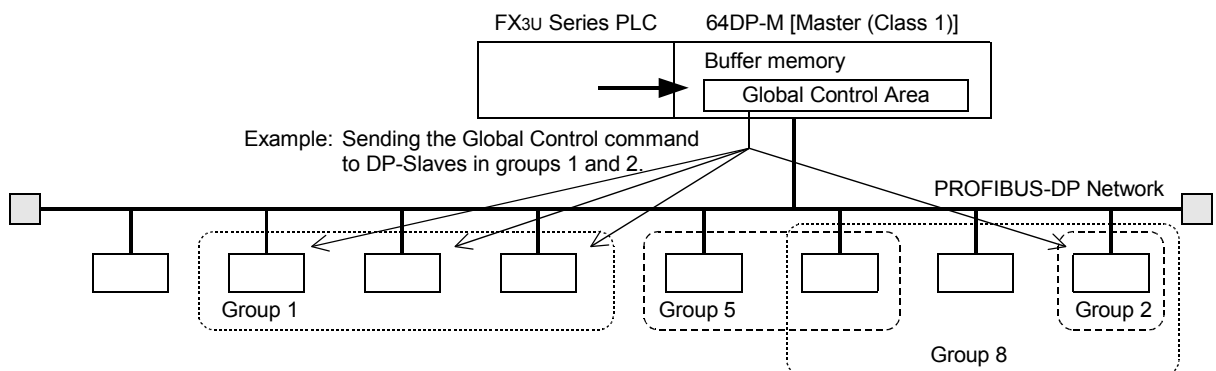

### 5.4.1 SYNC and UNSYNC Global Control

The SYNC/UNSYNC Global Control controls the output data communication from the 64DP-M to the DP-Slave.

→ For details on Global Control, refer to Section 6.34  
→ For Cyclic Output Data, refer to Section 5.1 and 6.34.1

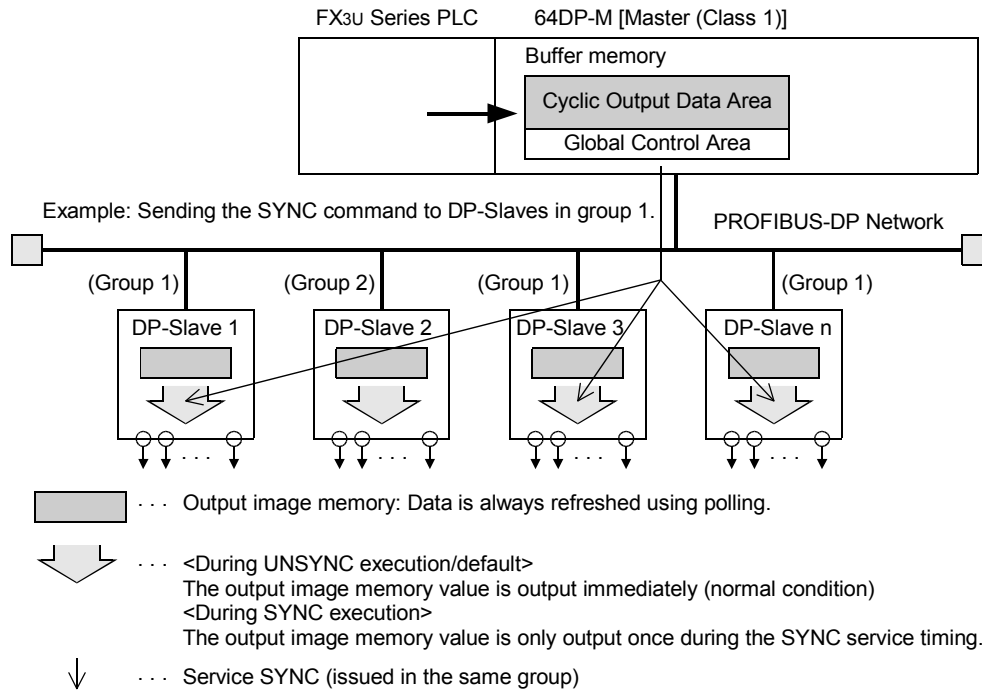

- 1) SYNC Global Control command  
In SYNC mode, the output data sent to DP-Slaves in the group specified by BFM #9390 is not immediately written to the actual physical outputs of the DP-Slave. The output data are stored inside the DP-Slaves until the next SYNC/UNSYNC Global Control command is sent, then the output data of those DP-Slaves are updated. The first SYNC command sent to the DP-Slaves will switch them into SYNC mode.
- 2) UNSYNC Global Control command  
When sending an UNSYNC Global Control command to a DP-Slave which is in SYNC mode, the DP-Slave will be released from SYNC mode and will update the output data continuously.  
By specifying a group of DP-Slaves in BFM #9390, the UNSYNC command is sent to arbitrary DP-Slaves, similar to the SYNC command.

#### Note

When using the SYNC Global Control command, output data (sent to the DP-Slave) is not refreshed until the next SYNC or UNSYNC global command is sent to the DP-Slave. That is, even if new data is written to the Output Data Area (BFM #2350 to #3373) by TO instructions, etc., it is not refreshed until the following SYNC or UNSYNC global command is issued from the PROFIBUS-DP in SYNC Global Control Mode.

### 5.4.2 FREEZE and UNFREEZE Global Control

The FREEZE/UNFREEZE Global Control controls the input data communication from the DP-Slave to the 64DP-M.

→ For details on Global Control, refer to Section 6.34  
→ For Cyclic Input Data, refer to Section 5.1 and 6.23

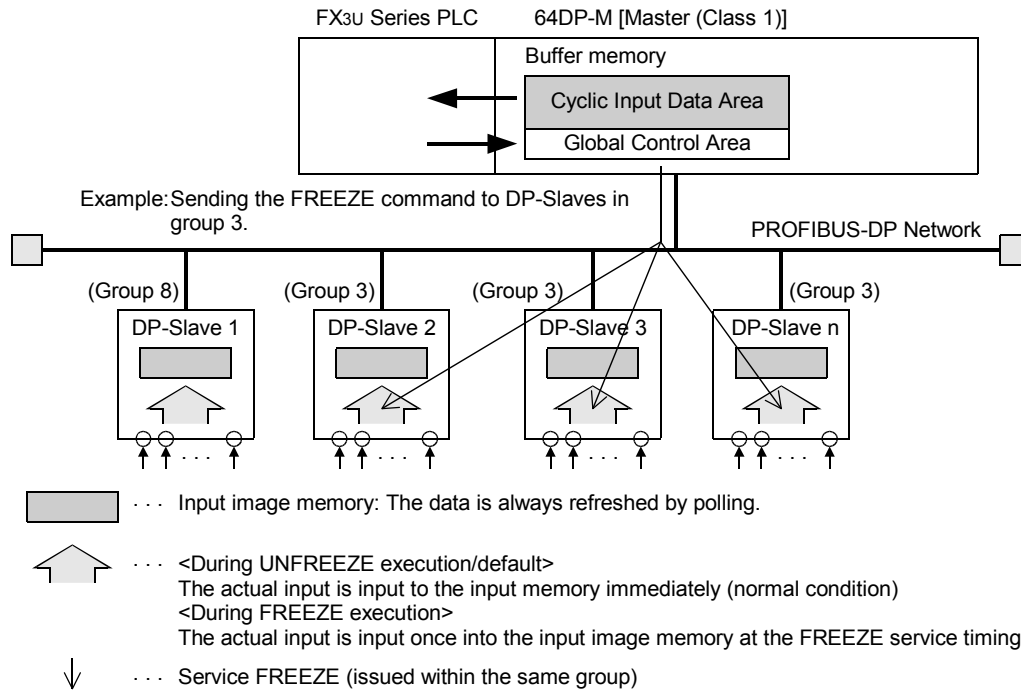

- 1) FREEZE Global Control command  
In Freeze mode, the input data of DP-Slaves in the group specified by BFM #9390 is set to freeze (no cyclical refresh of input data).  
Only after sending another FREEZE/UNFREEZE Global Control command to the DP-Slaves, the input data to the 64DP-M is updated.
- 2) UNFREEZE Global Control command  
When sending an UNFREEZE Global Control command to a DP-Slave which is in FREEZE mode, the DP-Slave will be released from FREEZE mode and update the input data continuously.  
By specifying a group of DP-Slaves in BFM #9390, the UNFREEZE command can be performed on arbitrary DP-Slaves, similar to the FREEZE command.

#### Note

When using FREEZE Global Control command, input data (received from DP-Slave) is not refreshed until next FREEZE or UNFREEZE global command is send to the DP-Slave.  
That is, even if the input (receive) data from the DP-Slave reads the Input Data Area (BFM #350 to #1373) by FROM instructions, etc., this is not refreshed until the following FREEZE or UNFREEZE global command is issued from the PROFIBUS-DP in FREEZE Global Control Mode.

## 6. Allocation of Buffer Memories (BFMs)

### 6.1 Buffer Memories (BFM) Lists

BFM No.	Description	BFMs Access		Reference
		read	write	
BFM #0	Communication Status	✓	-	6.2
BFM #1	Communication Control Flags	✓	✓	6.3
BFM #2	Consistency Handling Error Flags	✓	✓	6.4
BFM #3	PROFIBUS Error Flags	✓	✓	6.5
BFM #4	Dwell Time Flag / Whole Config Data Exchange Flag	✓	✓	6.6
BFM #5	Module READY Signal	✓	-	6.7
BFM #6	Current PROFIBUS (bus) cycle time for cyclic data exchange	✓	-	6.8
BFM #7	Min. PROFIBUS (bus) cycle time for cyclic data exchange	✓	-	
BFM #8	Max. PROFIBUS (bus) cycle time for cyclic data exchange	✓	-	
BFM #9 to BFM #17	Not used	-	-	-
BFM #18 to BFM #21	Acyclic Slave Communication Deactivation Message Flags	✓	✓	6.9
BFM #22 to BFM #25	Not used	-	-	-
BFM #26	PROFIBUS Module ID: PNO-Nr. F364 Hex	✓	-	6.10
BFM #27	Master Reset	✓	✓	6.11
BFM #28	Setting Error Flags	✓	✓	6.12
BFM #29	Master Error Status	✓	✓	6.13
BFM #30	Module ID Code: K7140	✓	-	6.14
BFM #31	PROFIBUS Master Address	✓	-	6.15
BFM #32	PROFIBUS Transmission Speed	✓	-	6.16
BFM #33	Clear Control Flag	✓	✓	6.17
BFM #34	PROFIBUS Error Mask Flag	✓	✓	6.18
BFM #35 to BFM #37	Not used	-	-	-
BFM #38	Number of Allocated Slaves	✓	-	6.19
BFM #39	Operation Service Mode	✓	✓	6.20
BFM #40 to BFM #72	Not used	-	-	-
BFM #73 to BFM #76	Data Swap Activate Flag	✓	✓	6.21
BFM #77 to BFM #80	Not used	-	-	-
BFM #81	Change Slave FDL Address Flag	This BFM is used to change the Slave FDL address	✓	6.22
BFM #82	Old Slave FDL address		✓	
BFM #83	New Slave FDL address		✓	
BFM #84 to BFM #87	Cyclic Input Data Consistency Activate/Deactivate Flags	✓	✓	6.23.1
BFM #88 to BFM #91	Not used	-	-	-
BFM #92 to BFM #95	Cyclic Output Data Consistency Activate/Deactivate Flags	✓	✓	6.24.1

1

Introduction

2

Specifications

3

Installation

4

Wiring

5

Mode-  
Data Comms.,  
Global Control

6

Allocation of  
Buffer Memories  
(BFMs)

7

Setting  
Parameters and  
Configuration

8

Example  
Program

9

Diagnostics

BFM No.	Description		BFMs Access		Reference
			read	write	
BFM #96 to BFM #99	Not used		-	-	-
BFM #100 to BFM #163	Cyclic Input Data Request Flags	This flag is used to exchange the cyclic input data of more than 16 bits to DP-Slaves.	✓	✓	6.23.2
BFM #164 to BFM #224	Not used		-	-	-
BFM #225 to BFM #288	Cyclic Output Data Send Flags	This flag is used to exchange the cyclic output data of more than 16 bits to DP-Slaves.	✓	✓	6.24.2
BFM #289 to BFM #349	Not used		-	-	-
BFM #350 to BFM #1373	Cyclic Input Data Area	<p>Reads input data of cyclic communication from this area.</p> <ul style="list-style-type: none"> <li>• Normal Service Mode (Mode 0): 32 bytes/slave</li> <li>• Extended Service Mode (Mode 3): Maximum 244 bytes/slave, total 2048 bytes for all DP-Slaves</li> </ul>	✓		6.23.3
BFM #1374 to BFM #2349	Not used		-	-	-
BFM #2350 to BFM #3373	Cyclic Output Data Area	<p>Writes output data of cyclic communication to this area.</p> <ul style="list-style-type: none"> <li>• Normal Service Mode (Mode 0): 32 bytes/slave</li> <li>• Extended Service Mode (Mode 3): Maximum 244 bytes/slave, total 2048 bytes for all DP-Slaves</li> </ul>	✓	✓	6.24.3
BFM #3374 to BFM #4499	Not used		-	-	-
BFM #4500 to BFM #4503	Acyclic Input Data Request Flags	This flag is used to exchange the Acyclic Input Data for each acyclic DP-Slave channel.	✓	✓	6.25.1
BFM #4504 to BFM #4509	Not used		-	-	-
BFM #4510 to BFM #4513	Acyclic Output Data Send Flags	This flag is used to exchange the Acyclic Output Data for each acyclic DP-Slave channel.	✓	✓	6.26.1
BFM #4514 to BFM #4519	Not used		-	-	-
BFM #4520 to BFM #5015	Acyclic Input Data Area	<p>Reads input data of Acyclic Communication for each acyclic DP-Slave channel from this area.</p> <p>4 acyclic DP-Slave channel, maximum 240 (248) bytes/channel</p>	✓	✓	6.25.2
BFM #5016 to BFM #5759	Not used		-	-	-
BFM #5760 to BFM #6255	Acyclic Output Data Area	<p>Writes output data of Acyclic Communication for each acyclic DP-Slave channel to this area.</p> <p>4 acyclic DP-Slave channel, maximum 240 (248) bytes/channel</p>	✓	✓	6.26.2
BFM #6256 to BFM #6999	Not used		-	-	-



BFM No.	Description		BFMs Access		Reference
			read	write	
BFM #7000 to BFM #7003	Master/Slave Internal Parameter Error Flags	ON when Master/Slave Internal Parameter Error occurs during DP-Slave's initialization.	✓	✓	6.27
BFM #7004 to BFM #7007	Not used		-	-	-
BFM #7008 to BFM #7071	Master/Slave Internal Parameter Error Data	Checks this error data, when Master/Slave Internal Parameter Error occurs.	✓	✓	6.28
BFM #7072 to BFM #7199	Not used		-	-	-
BFM #7200 to BFM #7203	Slave Diagnostic Status Flags	ON when receiving the Slave Diagnostic Information from DP-Slave.	✓	✓	6.29.1
BFM #7204 to BFM #7207	Not used		-	-	-
BFM #7208	Slave Diagnostic Request	Sets to ON when storing the current Slave Diagnostic Information of specified DP-Slave by BFM #7209 to BFM #7210 to #7335.	✓	✓	6.29.2
BFM #7209	Slave Number	Writes to Slave number which stores the current Slave Diagnostic Information to BFM #7210 to #7335.	✓	✓	6.29.3
BFM #7210 to BFM #7335	Slave Diagnostic Information Data	Read the current Slave Diagnostic Information from this area.	✓	-	6.29.4
BFM #7336	FIFO Diagnostic Request	Sets to ON when storing the FIFO Slave Diagnostic Information of specified DP-Slave to BFM #7338 to #7463.	✓	✓	6.30.1
BFM #7337	Internal FIFO Counter	This value is number of stocked Slave Diagnostic Information in Internal Diagnostic FIFO Area. 64DP-M can stock up to 64 information in Internal Diagnostic FIFO Area.	✓	-	6.30.2
BFM #7338 to BFM #7463	Diagnostic FIFO Data Area	Reads the FIFO Slave Diagnostic Information from this area.	✓	-	6.30.3
BFM #7464 to BFM #7591	Slave Diagnostic Status Data	Shows an overview of each DP-Slave over the PROFIBUS diagnosis.	✓	-	6.31
BFM #7592 to BFM #8783	Not used		-	-	-
BFM #8784 to BFM #8787	Automatic Acknowledge Setting	Sets this flag when using Automatic Acknowledge Function for Alarm Message. Default setting: PROFIBUS-DP V1 slave = 1	✓	✓	6.32.1
BFM #8788 to BFM #8791	Not used		-	-	-
BFM #8792 to BFM #8795	Alarm Acknowledge Status	Shows the Alarm Acknowledge status when not using Automatic Acknowledge Function. ON when a receiving Alarm was read by the PLC program but not yet Acknowledge.	✓	-	6.32.2
BFM #8796 to BFM #8799	Not used		-	-	-

1	Introduction
2	Specifications
3	Installation
4	Wiring
5	Mode-Data Comms., Global Control
6	Allocation of Buffer Memories (BFMs)
7	Setting Parameters and Configuration
8	Example Program
9	Diagnostics

BFM No.	Description		BFMs Access		Reference
			read	write	
BFM #8800 to BFM #8803	Alarm Message Status	Shows Alarm Message Status when using Automatic Acknowledge Function. ON when receiving Alarm Message from DP-Slave.	✓	✓	6.32.3
BFM #8804 to BFM #8807	Not used		-	-	-
BFM #8808 to BFM #8871	Alarm Message Counter	Shows the number of stocked Alarm Messages for each DP-Slave when not using Automatic Acknowledge Function. 64DP-M can stock up to 2 Alarm Messages in Internal Alarm Message FIFO Area.	✓	-	6.32.4
BFM #8872 to BFM #8932	Not used		-	-	-
BFM #8933	Alarm Message Request	Sets to ON when storing the Alarm Message of specified DP-Slave by BFM #8934 to BFM #8935 to #8969.	✓	✓	6.32.5
BFM #8934	Request Slave Number	Write to slave number for storing the Alarm Message to BFM #8935 to #8969.	✓	✓	6.32.6
BFM #8935 to BFM #8969	Alarm Message	Read the Alarm Message from this area.	✓	-	6.32.7
BFM #8970	Alarm ACK Request	Sets to ON when sending the Acknowledge for Alarm Message to specified DP-Slave by BFM #8971.	✓	✓	6.32.8
BFM #8971	Slave Number	Writes the slave number which sends Acknowledge for Alarm Message.	✓	✓	6.32.9
BFM #8972 to BFM #9139	Not used		-	-	-
BFM #9140 to BFM #9267	Address Information Area	Shows the Slave FDL address and I/O data length of each project DP-Slave.	✓	-	6.33
BFM #9328 to BFM #9389	Not used		-	-	-
BFM #9390	Global Control Area	Writes the Global Control Command and groups when issuing Global Control Command.	✓	✓	6.34.1
BFM #9391 to BFM #9393	Not used		-	-	-
BFM #9394	Information Dwell Time Setting	Writes the dwell time (in 1 second steps) which does not detect Diagnostic Information after exchange start. Default: K4 (4 sec)	✓	✓	6.35
BFM #9395 to BFM #9398	Not used		-	-	-
BFM #9399 to BFM #9402	Cyclic Slave Status Area	The status flag of corresponding DP-Slave is ON when the I/O data via cyclic communication exchanges.	✓	-	6.36
BFM #9403 to BFM #9406	Not used		-	-	-

BFM No.	Description		BFMs Access		Reference
			read	write	
BFM #9407 to BFM #9410	Acyclic Slave Status Area	The status flag of the corresponding DP-Slave is ON when the I/O data is being exchanged via Acyclic Communication Exchange.	✓	-	6.37
BFM #9411 to BFM #9425	Not used		-	-	-
BFM #9426 to BFM #9489	Cyclic Input Data Start Address Area	Shows the starting address of cyclic input data for each DP-Slave.	✓	-	6.38
BFM #9490 to BFM #9550	Not used		-	-	-
BFM #9551 to BFM #9614	Cyclic Output Data Start Address Area	Shows the starting address of cyclic output data for each DP-Slave.	✓	-	6.39
BFM #9615 to BFM #9675	Not used		-	-	-
BFM #9676	Number of Configured Slaves	Shows the total number of configured DP-Slaves.	✓	-	6.40
BFM #9677 to BFM #9868	Slave Number, Slave FDL Address, Slave PNO ID	Shows the Slave Number, Slave FDL address and PNO-ID of each projected DP-Slave.	✓	-	6.41
BFM #9869 to BFM #10051	Not used		-	-	-
BFM #10052	Get Slave List Request	Set to ON when using the PROFIBUS Scan Function in all modes except Cyclic Exchange Mode. Lists the following detected DP-Slave information on PROFIBUS-DP network when using this function. <ul style="list-style-type: none"> <li>• Configuration difference list</li> <li>• Total number of detected DP-Slave</li> <li>• Slave Number, Slave FDL address and PNO-ID of each detected DP-Slave</li> </ul>	✓	✓	6.42.1
BFM #10053 to BFM #10060	Configuration Difference Satus	The status flag of the corresponding DP-Slave is ON when discrepancies exist between the projected configuration and the detected configuration.	✓	-	6.42.2
BFM #10061	Scan Slave FDL Address	Shows the current scanned address. After the scan, this value is set to 0. May not show it because speed scanning is faster in high baud rate setting.	✓	-	6.42.3
BFM #10062	Number of Detected Slave	Shows total number of detected DP-Slaves.	✓	-	6.42.4
BFM #10063 to BFM #10443	Detected Slave List	Shows the Slave Number, Slave FDL address and PNO-ID of each detected DP-Slave.	✓	-	6.42.5
After BFM #10444	Not used		-	-	-

**Caution**

Do not access the buffer memory that is marked as "Not used" (Ex. BFM #9 to #17, #22 to #25, #35 to #37, #40 to #72, etc.) by FROM/TO instructions. There is a possibility to cause abnormal behavior to the operation of the 64DP-M if accessing these buffer memories.

1	Introduction
2	Specifications
3	Installation
4	Wiring
5	Mode-Data Comms., Global Control
6	Allocation of Buffer Memories (BFMs)
7	Setting Parameters and Configuration
8	Example Program
9	Diagnostics

## 6.2 Communication Status [BFM #0]

**BFM Access: Read Only**

Communication status on PROFIBUS-DP network shows by the following value in BFM #0.

Value	Description
K0	64DP-M is in STOP mode.
K1	64DP-M is in RUN mode. 64DP-M can exchange data to DP-Slaves in this RUN mode.
K2	64DP-M is in Offline mode. There is no communication and no Token on the PROFIBUS-DP network.
K3	64DP-M is in Clear mode. 64DP-M only reads Input data.
K4	64DP-M is in AutoClear mode. 64DP-M only reads Input data. 64DP-M changes in this mode when "Error Action Flag" is set up by GX Configurator-DP and communication problem occurs on PROFIBUS-DP network.

## 6.3 Communication Control Flags [BFM #1]

**BFM Access: Read / Write**

The Communication Control Flags are allocated as described in the following table.

→ For details on the startup procedure, refer to the next page

Bit No.	Name	Description
Bit 0	Data Exchange Start Request Flag	The Data Exchange Start Request Flag is used for exchanging data between the 64DP-M and the DP-Slaves on the PROFIBUS-DP network. If this Bit is set to ON, the PROFIBUS Mode changes from STOP mode to RUN mode. Before turning this bit ON, the 64DP-M must be in STOP mode, Clear or AutoClear mode (BFM #0). Changing this Bit from ON to OFF sets the PROFIBUS Mode from RUN mode to STOP mode. If the PLC is switched from RUN to STOP mode or if the PLC has a PROG error or CPU error, the 64DP-M will automatically be set to STOP mode.
Bit 1 to 15	Not used	

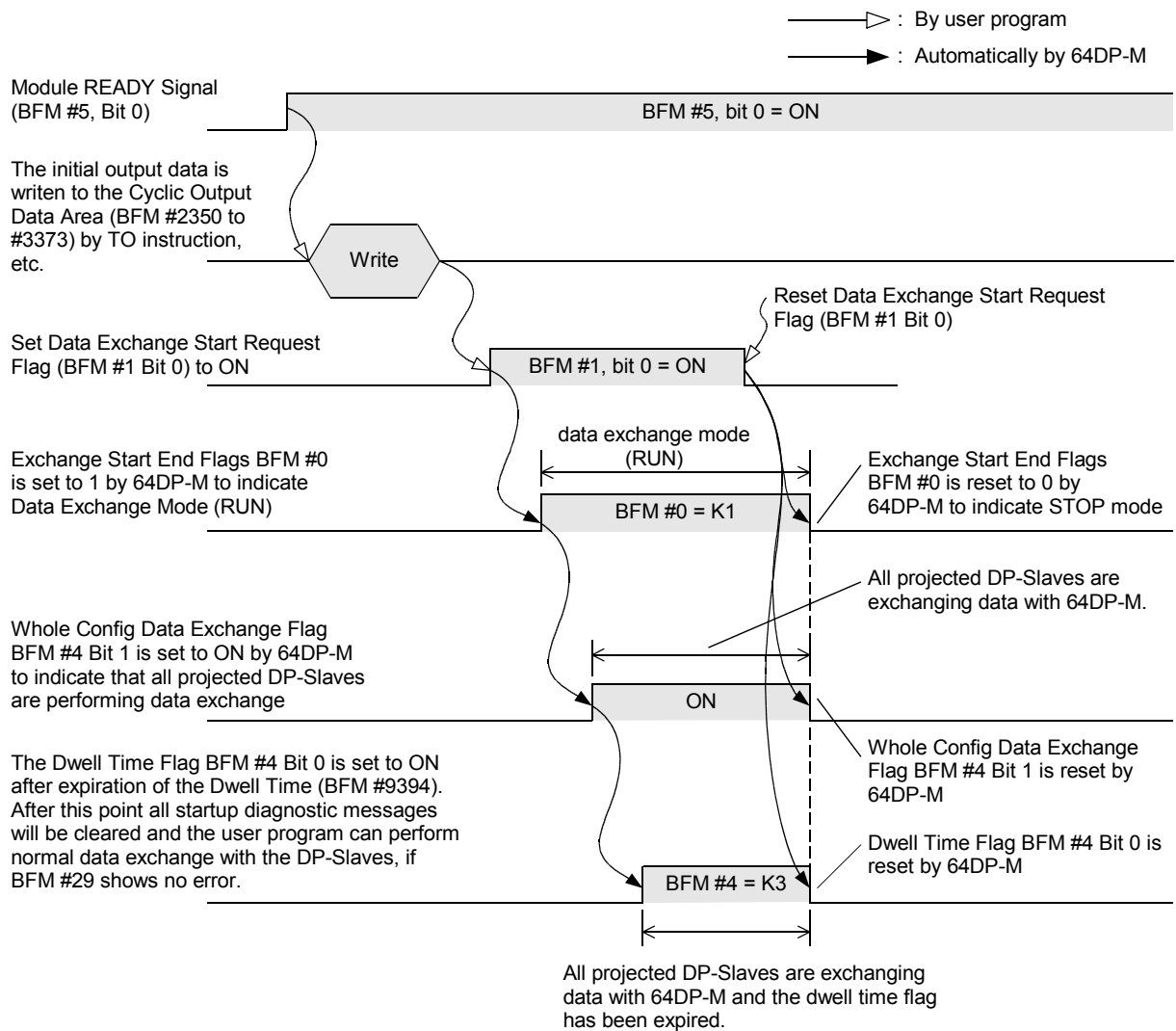

1	Introduction
2	Specifications
3	Installation
4	Wiring
5	Mode-Global Control
6	Allocation of Buffer Memories (BFMs)
7	Setting Parameters and Configuration
8	Example Program
9	Diagnostics

## 6.4 Consistency Handling Error Flags [BFM #2]

**BFM Access: Read / Write**

These Bits show the reasons for a consistency error. These Bits can be reset by writing a 0 to each Bit. If any of these Bits are ON, the corresponding Bit in BFM #29 Bit 5 will also be ON. Resetting BFM #29 Bit 5 will also clear BFM #2 to K0.

An error will occur if reading/writing BFMs during the respective consistency flag are not turned to OFF.

Bit No.	Name	Description
Bit 0	Cyclic Input Data Exchange Consistency Error	This Bit is set to ON if reading input data from a DP-Slave, while the Input Data Consistency Flag of this DP-Slave is ON.
Bit 1	Cyclic Output Data Exchange Consistency Error	This Bit is set to ON if writing output data to a DP-Slave, while the Output Data Consistency Flag of this DP-Slave is ON.
Bit 2	Acyclic Input Data Exchange Consistency Error	This Bit is set to ON if reading input data from acyclic input, while the Acyclic Input Data Request Flag of this channel is ON.
Bit 3	Acyclic Input Data Request Exchange Consistency Error	This Bit is set to ON if writing a request to an acyclic input channel, while the Acyclic Input Data Request Flag of this channel is ON.
Bit 4	Acyclic Output Data Exchange Consistency Error	This Bit is set to ON if writing output data to an acyclic output channel, while the Acyclic Output Data Send Flag of this channel is ON.
Bit 5	Acyclic Output Data Request Exchange Consistency Error	This Bit is set to ON if writing a request to an acyclic output channel, while the Acyclic Output Data Send Flag of this channel is ON.
Bit 6	Slave Diagnostic Read Consistency Error	This Bit is set to ON if reading diagnostic information from a DP-Slave, while the Slave Diagnostic Request Flag of this DP-Slave is ON.
Bit 7	Slave Diagnostic Read Request Consistency Error	This Bit is set to ON if writing a diagnostic information request to a DP-Slave, while the Slave Diagnostic Request Flag of this DP-Slave is ON.
Bit 8	FIFO Diagnostic Read Consistency Error	This Bit is set to ON if reading a FIFO diagnostic information, while the FIFO Diagnostic Request Flag is ON.
Bit 9	FIFO Diagnostic Read Request Consistency Error	This Bit is set to ON if writing a FIFO Diagnostic Request, while the FIFO Diagnostic Request Flag is ON.
Bit 10	Read Alarm Consistency Error	This Bit is set to ON if reading a Alarm Message, while the Alarm Message Request Flag is ON.
Bit 11	Read Alarm Request Consistency Error	This Bit is set to ON if writing a Alarm Message Request, while the Alarm Message Request Flag is ON.
Bit 12	Alarm Acknowledge Write Consistency Error	This Bit is set to ON if writing a new value to the Alarm ACK request Slave Number, while the Alarm ACK request Flag is ON.
Bit 13	Alarm Acknowledge Write Request Consistency Error	This Bit is set to ON if writing an Alarm ACK request, while the Alarm ACK request Flag is ON.
Bit 14	Change Slave FDL Address Consistency Error	This Bit is set to ON if reading the Slave FDL address, while the Change Slave FDL Address Flag is ON.
Bit 15	Change Slave FDL Address Request Consistency Error	This Bit is set to ON if writing a Slave FDL address Change Request, while the Change Slave FDL Address Flag is ON.

## 6.5 PROFIBUS Error Flags [BFM #3]

**BFM Access: Read / Write**

These Bits show the reasons for a PROFIBUS error. If any of these Bits are ON, the corresponding Bit in BFM #29 Bit 8 will also be ON. These Bits can be reset by writing a 0 to each Bit. Resetting BFM #29 Bit 8 will also clear BFM #3 to 0.

An error occurs if there is a problem with the PROFIBUS.

Bit No.	Name	Description
Bit 0	Conflict of Addresses	Conflict of addresses. The address of the 64DP-M has already been assigned. If this error occurs, 64DP-M will change to Offline mode. The 64DP-M has to be set to STOP mode before RUN mode can be set.
Bit 1	Bus Protocol is disturbed (faulty bus termination)	The bus protocol is disturbed. Possible causes are missing or faulty termination resistors. If this error occurs, 64DP-M will change to STOP mode unless BFM #34 Bit 0 is ON.
Bit 2	Bus Protocol is disturbed	The bus protocol is disturbed. Possible causes are stations beyond the Highest Station Address (HSA), or the transmitted frame could not be read back. If this error occurs, 64DP-M will change to Offline mode. The 64DP-M has to be set to STOP mode before RUN mode can be set.
Bit 3	Master State Hardware Error	Possible causes are deviations from required bus idle times, frames longer than 256 bytes or interrupted data streams. If this error occurs, 64DP-M will change to Offline mode. The 64DP-M has to be set to STOP mode before RUN mode can be set.
Bit 4 to 15	Not used	

### Note

If any of Bit 0, Bit 2 or Bit 3 is ON while the 64DP-M is in cyclic data exchange (RUN) mode, the 64DP-M will automatically change to Offline mode.

## 6.6 Dwell Time Flag / Whole Config Data Exchange Flag [BFM #4]

**BFM Access: Read Only**

The Communication Control Flags are allocated as follows.

Bit No.	Name	Description
Bit 0	Dwell Time Flag	This flag is set to ON after expiration of the dwell time (BFM #9394).
Bit 1	Whole Config Data Exchange Flag	This flag is set to ON after all projected PROFIBUS slaves have entered data exchange with the 64DP-M. If one or more DP-Slaves of the downloaded GX Configurator-DP project are disconnected from the PROFIBUS, this flag will be automatically reset.
Bit 2 to 15	Not used	

### Note

- For startup of the PROFIBUS network, it is advisable to evaluate the content of BFM #4 in the user program. Only after the dwell time has expired and all DP-Slaves are in data exchange is it safe to trust the input data of the DP-Slaves in the 64DP-M's BFM. If the content of BFM #4 is different from K3, either not all DP-Slaves are participating in cyclic data exchange, or the dwell time has not expired yet, which means that there might be DP-Slaves that have a diagnostics Information which is not yet recognized by the 64DP-M.
- If it is essential to the application that the communication is discontinued in case of an error, the "Error Action Flag" in GX Configurator-DP (Master Settings) "Goto Clear Flag" should be selected. Additionally, the watchdog timer for the cyclic communication with the DP-Slaves should be set.

## 6.7 Module READY Signal [BFM #5]

**BFM Access: Read Only**

The Module READY Signal is allocated as follows.

Bit No.	Name	Description
Bit 0	Module READY Signal	During startup (boot) time of the 64DP-M, the Module READY Signal is ON. After the 64DP-M has completed the internal startup procedure and all BFMs are initialized, the flag is set to ON. Data exchange (BFM #1) should start after this flag becomes ON (BFM #5 = K1).
Bit 1 to 15	Not used	

## 6.8 PROFIBUS (Bus) Cycle Time [BFM #6 to #8]

**BFM Access: Read Only**

The PROFIBUS (bus) cycle time is the time between two data exchange cycles of one DP-Slave. The value is adjusted in 1 ms steps.

BFM No.	Description
BFM #6	Current PROFIBUS (bus) cycle time; Default value: 0
BFM #7	Min. PROFIBUS (bus) cycle time; Default value: FFFF (hex)
BFM #8	Max. PROFIBUS (bus) cycle time; Default value: 0

The current PROFIBUS (bus) cycle time can be seen from BFM #6 during data exchange. The minimum / maximum PROFIBUS (bus) cycle time can be seen from BFM #7 / #8 during data exchange after expiration of the dwell time. The setting of the DP-Slave watchdog time in the GX Configurator-DP must be longer than the maximum PROFIBUS (bus) cycle time (BFM #8).

## 6.9 Acyclic Slave Communication Deactivation Message Flags [BFM #18 to #21]

**BFM Access: Read / Write (only reset to 0)**

These Bits show the deactivation message of the Acyclic Communication for each DP-Slave. If the Bit is ON, then the Acyclic Communication with this Slave has been stopped. These flags are turned on by the 64DP-M if an error has occurred during Acyclic Communication, or in General, after the 64DP-M has switched to STOP mode during slave Acyclic Communication. The reasons for closing the Acyclic Communication channel can be that a DP-Slave is not participating in acyclic communication any more, the DP-Slave is receiving new parameter data while in cyclic communication mode, or the watchdog timer of the DP-Slave has expired. If BFM #18 to #21 is different from 0, the corresponding error Bit in BFM #29 Bit 7 will be set to ON. Resetting BFM #29 Bit 7 will also clear the contents of BFM #18 to #21. Switching the 64DP-M from STOP mode to RUN mode (cyclic data exchange), will also clear the contents of BFM #18 to #21.

BFM No.	Bit No.	Station No.	BFM No.	Bit No.	Station No.
BFM #18	Bit 0	1	BFM #20	Bit 0	33
	Bit 1	2		Bit 1	34
	Bit 2	3		Bit 2	35
	⋮	⋮		⋮	⋮
	Bit 15	16		Bit 15	48
BFM #19	Bit 0	17	BFM #21	Bit 0	49
	Bit 1	18		Bit 1	50
	Bit 2	19		Bit 2	51
	⋮	⋮		⋮	⋮
	Bit 15	32		Bit 15	64



## 6.10 PROFIBUS Module ID (PNO ID) [BFM #26]

**BFM Access: Read Only**

Shows the PROFIBUS Module ID from PNO. The value is "F364" Hex.

## 6.11 Master Reset [BFM #27]

**BFM Access: Read / Write**

When the Master Reset Request is set to K2 the 64DP-M will do a Hardware reset. This reset is equivalent to a Power down reset. After the reset, this Register will automatically be erased to K0.

## 6.12 Setting Error Flags [BFM #28]

**BFM Access: Read / Write**

The following table shows the reasons for a setting error BFM #29 Bit 4. The Bits can be reset by writing a 0 to each Bit.

Bit No.	Description
Bit 0	Write access to "Not used" or "read only" BFM has occurred
Bit 1	Wrong value was written to BFM #1 (Communication Control Flag), to BFM #33 (Clear Control Flag) or to BFM #34 (PROFIBUS Error Mask Flag)
Bit 2	Not used
Bit 3	Wrong value was written to BFM #27 (Master Reset)
Bit 4	<ul style="list-style-type: none"> <li>Wrong value was written to BFM #39 (Operation Mode)</li> <li>Write access to BFM #39 while 64DP-M was not in STOP or Offline mode</li> </ul>
Bit 5	<ul style="list-style-type: none"> <li>Wrong value was written to BFM #81 to #83 (Change Slave FDL Address)</li> <li>Write access while 64DP-M was not in STOP mode (Change Slave FDL Address)</li> </ul>
Bit 6	<ul style="list-style-type: none"> <li>Wrong value was written to BFM #100 to #163 (Cyclic Input Data Request Flag)</li> <li>Wrong value was written to BFM #225 to #288 (Cyclic Output Data Send Flag)</li> </ul>
Bit 7	<ul style="list-style-type: none"> <li>Wrong value was written to BFM #4500 to #4503 (Acyclic Input Data Request Flag)</li> <li>Unused slave number was written to acyclic input request channel BFM #4520, #4644, #4768 or #4892</li> <li>Write request while 64DP-M is in STOP or Offline mode</li> </ul>
Bit 8	<ul style="list-style-type: none"> <li>Wrong value was written to BFM #4510 to #4513 (Acyclic Output Data Send Flag)</li> <li>Unused slave number was written to acyclic output request channel BFM #5760, #5884, #6008 or #6132</li> <li>Write request while 64DP-M is in STOP or Offline mode</li> </ul>
Bit 9	<ul style="list-style-type: none"> <li>Wrong request value was written to BFM #7208</li> <li>Unused slave number was written to BFM #7209</li> <li>Write request while 64DP-M is in STOP or Offline mode (Slave Diagnostic)</li> </ul>
Bit 10	<ul style="list-style-type: none"> <li>Wrong request value was written to BFM #7336 (FIFO Diagnostic request)</li> <li>Wrong value was written to BFM #7337 (only K0 is allowed)</li> </ul>
Bit 11	<ul style="list-style-type: none"> <li>Wrong value was written to BFM #8933</li> <li>Unused slave number was written to BFM #8934</li> <li>Write request was executed while 64DP-M was in STOP or Offline mode (slave alarm)</li> </ul>
Bit 12	<ul style="list-style-type: none"> <li>Wrong value was written to BFM #8970</li> <li>Unused slave number was written to BFM #8971</li> <li>Write request was executed while 64DP-M was in STOP or Offline mode (slave alarm acknowledge)</li> </ul>
Bit 13	<ul style="list-style-type: none"> <li>Wrong value was written to BFM #9390</li> <li>Write request was executed while 64DP-M was in STOP or Offline mode (Global Control Area)</li> </ul>
Bit 14	<ul style="list-style-type: none"> <li>Wrong value was written to BFM #9394 (Information Dwell Time Setting)</li> </ul>
Bit 15	<ul style="list-style-type: none"> <li>Wrong value was written to BFM #10052</li> <li>Write request was executed while 64DP-M was not in STOP mode (Get slave list request)</li> </ul>

1

Introduction

2

Specifications

3

Installation

4

Wiring

5

Mode-  
Data Comms.,  
Global Control

6

Allocation of  
Buffer Memories  
(BFMs)

7

Setting  
Parameters and  
Configuration

8

Example  
Program

9

Diagnostics

## 6.13 Master Error Status [BFM #29]

**BFM Access: Read / Write**

The Master Status buffer memory is allocated as shown in the following table. All Bits (0 to 15) are latched until turned OFF by user program, or until power down or next reset. Switching the 64DP-M from STOP mode into RUN mode (data exchange mode), will also clear the latched error flags if the error does not exist any more.

Bit No.	Name	Description	Reference (Subsection)
Bit 0	Master Reset Status Flag	ON when the value of the Master Reset buffer memory (BFM #27) is "K2".	6.13.1
Bit 1	Master Hardware Error	ON when there is a Hardware error	6.13.2
Bit 2	Not used		-
Bit 3	Slave Parameter Error	ON when the 64DP-M has detected a parameter error at a DP-Slave.	6.13.3
Bit 4	Setting Error Flag	ON when the user settings are wrong.	6.13.4
Bit 5	Consistency Error Flag	ON when there is an error in consistency handling	6.13.5
Bit 6	Not used		-
Bit 7	Acyclic Communication Deactivation Flag	ON when the Acyclic Communication channel of a DP-Slave is deactivated.	6.13.6
Bit 8	PROFIBUS Error	ON when there is a PROFIBUS error.	6.13.7
Bit 9	Slave Diagnosis Available	ON when a DP-Slave has sent a diagnosis.	6.13.8
Bit 10	Slave Alarm Message Available	ON when a DP-Slave has sent an alarm.	6.13.9
Bit 11	No Configuration Available	ON when the 64DP-M has no Bus configuration	6.13.10
Bit 12	Mode Change Not Possible	ON if it is impossible to change from 3 to 0.	6.13.11
Bit 13	Diagnosis FIFO Full	ON when the diagnosis FIFO is full (64 entries)	6.13.12
Bit 14	Data Exchange Error	ON when one or more DP-Slaves stop the data exchange	6.13.13
Bit 15	Slave Change Address Error	ON when the Change Slave FDL Address was not successful	6.13.14

### Note

- When Bit 9 set to OFF by user program, all Slave Diagnostic Status Flags will be reset in BFM #7200 to #7203.
- When Bit 13 set to OFF by user program, all Internal FIFO Counters will be reset (cleared) and all Diagnostic FIFO Information will be reset in Internal Slave Diagnostic FIFO Area.

### 6.13.1 Master Reset Status Flag [BFM #29 Bit 0]

This Bit is set to ON after Software reset (BFM #27) and after Configuration download. It will be reset by writing a K0 and after Mode change from STOP to RUN.

### 6.13.2 Master Hardware Error [BFM #29 Bit 1]

This Bit is set to ON if the Hardware has an error (Module is damaged).  
If this error occurs, it is not possible for the 64DP-M to change into RUN mode (data exchange). If this error occurs while the 64DP-M is already in RUN mode, it will automatically be switched to STOP mode.  
If this Bit is ON the ERROR LED will be turned ON.

### 6.13.3 Slave Parameter Error [BFM #29 Bit 3]

The Slave parameter error flag is set to ON if the 64DP-M has received a parameter error from a DP-Slave. The DP-Slaves which have reported parameter errors are listed in BFM #7000 to #7003. The detailed reason for the parameter error is listed in BFM #7008 to #7071. Writing K0 will reset this Bit and the BFM #7000 to #7003 and BFM #7008 to #7071.

This Flag will be reset after the Mode changes from STOP to RUN.  
If this Bit is ON the ERROR LED will be permanently turned ON.

### 6.13.4 Setting Error Flag [BFM #29 Bit 4]

The Setting Error Flag is ON if accessing by FROM/TO instruction, etc. to a protected BFM, or if there is an invalid entry written to a BFM. BFM #28 shows detailed information of the setting error. Writing a K0 will reset this Bit together with BFM #28.

This Flag will be reset after the Mode changes from STOP to RUN.

If this Bit is ON the ERROR LED will be turned ON/OFF in 500ms intervals.

### 6.13.5 Consistency Error Flag [BFM #29 Bit 5]

The Consistency Error Flag is ON if there is an error in the data consistency handling detected. This Bit reflects the status of BFM #2. If any of the bits in BFM #2 is set to ON, BFM #29, Bit 5 is also set to ON. This error occurs if data is written to the 64DP-M or read from the 64DP-M, before the Output Data Send Flag or the Input Data Read Flag has been reset by the 64DP-M. Writing a K0 will reset this Bit together with BFM #2. This Flag will be reset after the Mode changes from STOP to RUN.

If this Bit is ON the ERROR LED will be turned ON/OFF in 500ms intervals.

### 6.13.6 Acyclic Communication Deactivation Message Flag [BFM #29 Bit 7]

The Acyclic Communication Deactivation Message Flag is ON if there is a shutdown of the acyclic communication channel with a DP-Slave. The reasons for closing the acyclic communication channel can be that a DP-Slave is not participating in acyclic communication any more, the DP-Slave is receiving new parameter data while it is in cyclic communication mode, or the watchdog timer of the DP-Slave has expired. BFM #18 to #21 shows the details on which DP-Slaves have been reported to have acyclic communication errors. Writing a K0 will reset this Bit together with the contents of BFM #18 to #21.

This Flag will be reset after the Mode changes from STOP to RUN.

If this Bit is ON the ERROR LED will be turned ON/OFF in 500ms intervals.

### 6.13.7 PROFIBUS Error Flag [BFM #29 Bit 8]

The PROFIBUS Error Flag is ON if there is a PROFIBUS problem. More details are displayed in BFM #3. Writing a K0 will reset this Bit together with BFM #3.

Attention: If this error occurs while the 64DP-M is cyclic data exchange (RUN) mode, the 64DP-M will automatically change to STOP/Offline mode unless BFM #34 Bit 0 is ON.

This Flag will be reset after the Mode changes from STOP to RUN if the error has been fixed in the meantime. If this Bit is ON the ERROR LED will be turned ON.

→ For details on BFM #34, refer to Section 6.18

### 6.13.8 Slave Diagnosis Available Flag [BFM #29 Bit 9]

The Slave Diagnosis Available Flag is ON if a DP-Slave has sent a diagnosis information. If any of the bits in BFM #7200 to #7203 is set to ON, BFM #29 Bit 9 is also set to ON. Writing a K0 to BFM #29 Bit 9 will clear this Bit together with the contents of BFM #7200 to #7203.

This Flag will be reset after the Mode changes from STOP to RUN.

If this Bit is ON the ERROR LED will be turn ON/OFF in 500ms intervals.

### 6.13.9 Alarm Message Available Flag [BFM #29 Bit 10]

The Alarm Message Available Flag is ON if a DP-Slave has sent an Alarm Message. If any of the bits in BFM #8800 to #8803 is set to ON, BFM #29 Bit 10 is also set to ON. Writing a K0 will reset this Bit only.

This Flag will be reset after the Mode changes from STOP to RUN.

If this Bit is ON the ERROR LED will be turned ON/OFF in 500ms intervals.

### 6.13.10 No Configuration Available Flag [BFM #29 Bit 11]

The No Configuration Available Flag is ON if there is no configuration stored in the 64DP-M. A default bus configuration without any projected DP-Slaves will be loaded. The default baud rate is 93.75 kbps and the default address is 0. Other default parameter data are matched accordingly.

This Flag is also set to ON if the Bus configuration has an error. After downloading a complete configuration from GX Configurator-DP, this flag will be cleared automatically.

If this Bit is ON the ERROR LED will be turned ON/OFF in 500ms intervals.

### 6.13.11 Mode Change Not Possible Flag [BFM #29 Bit 12]

---

The Mode Change Not Possible Flag is ON if changing the Operation Service Mode from 3 to 0 by writing to BFM #39 while at least one input or output area of a DP-Slave is greater than 32 Byte. Writing a K0 to BFM #29 Bit 12 will reset this Bit.

If this flag is ON, the 64DP-M will not change from STOP mode into RUN mode.

If this Bit is ON the ERROR LED will be turned ON/OFF in 500ms intervals.

### 6.13.12 Diagnosis FIFO Full [BFM #29 Bit 13]

---

The Diagnosis FIFO Full Flag is ON if the Diagnosis FIFO already contains 64 entries. Writing a K0 will reset this Bit together with the FIFO (contents of FIFO will be deleted).

This Flag will be reset after the Mode changes from STOP to RUN.

If this Bit is ON the ERROR LED will be turned ON/OFF in 500ms intervals.

#### Point

---

If this Bit is ON, 64DP-M can not stock the next Slave Diagnostic Information into Internal Diagnostic FIFO Area until this bit is reset. When this bit is reset, all FIFO Diagnostic Messages will be cleared.

→ For FIFO Diagnostic Message reading procedure, refer to Section 6.30

### 6.13.13 Data Exchange Error [BFM #29 Bit 14]

---

This Bit indicates a DP-Slave data exchange interruption error that has happened after the DP-Slave already entered cyclic data exchange with the 64DP-M. If a DP-Slave is interrupted in exchanging data with the 64DP-M, this Bit is set. Any DP-Slave that stops data exchange is cleared out of the list of BFM #9399 to #9402. This error can occur for example if a DP-Slave is removed from the network during cyclic data exchange.

#### Note

---

If it is essential to the application that communication is discontinued in case of an error, the "Error Action Flag" in GX Configurator-DP (Master Settings) "Goto Clear Flag" should be selected. Additionally the watchdog timer for the cyclic communication with the DP-Slaves should be set.

This Flag will be reset after the Mode changes from STOP to RUN.

If this Bit is ON the ERROR LED will be turned ON/OFF in 500ms intervals.

### 6.13.14 Slave Change Address Error [BFM #29 Bit 15]

---

The Change Slave FDL Address function (BFM #81 to #83) can only be used in STOP mode (BFM #0 = K0). If the change of a Slave FDL Address was not successful, an error will appear in BFM #29 Bit 15. The reasons for this error can be that the DP-Slave whose address was to be changed did not exist in the network, or that the DP-Slave did not support this service.

This Flag will be reset after the Mode changes from STOP to RUN.

If this Bit is ON the ERROR LED will be turned ON/OFF in 500ms intervals.

## 6.14 Module ID Code [BFM #30]

---

**BFM Access: Read Only**

The identification code for a 64DP-M is available using a FROM instruction. The identification code for the 64DP-M is K7140. By reading this identification code, the user may create built-in checking routines in the PLC program to check whether the physical position of 64DP-M matches the software.

## 6.15 PROFIBUS Master Address [BFM #31]

---

**BFM Access: Read Only**

This BFM shows the PROFIBUS Module address of the 64DP-M defined by the GX Configurator-DP.

## 6.16 PROFIBUS Transmission Speed [BFM #32]

**BFM Access: Read Only**

BFM #32 shows the current baud rate of the PROFIBUS-DP network. The following table shows the supported transmission speed and the value of BFM #32:

Value (Hex code)	Baud rate	Value (Hex code)	Baud rate
96E2H	9.6 kbps	15E5H	1.5 Mbps
19E3H	19.2 kbps	03E6H	3 Mbps
93E3H	93.75 kbps	06E6H	6 Mbps
18E4H	187.5 kbps	12E6H	12 Mbps
05E5H	500 kbps		

## 6.17 Clear Control Flag [BFM #33]

**BFM Access: Read / Write**

The Clear Control Flags are allocated as follows.  
The figure below shows the influence of BFM #33 on the behavior of the 64DP-M when the RUN/STOP mode is switched.

Bit No.	Name	Description
Bit 0	Clear Control Flag	If this flag is set and mode is changed from STOP mode to RUN or from RUN to STOP the 64DP-M does not go through the CLEAR mode. In CLEAR mode, the 64DP-M is exchanging only input data with the DP-Slaves, while the output data remain in the safe state.
Bit 1 to 15	Not used	

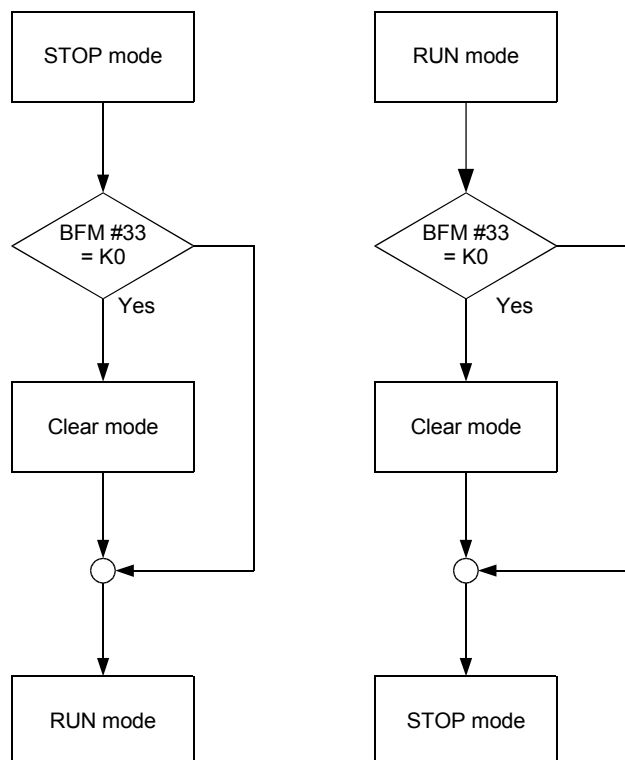

## 6.18 PROFIBUS Error Mask Flag [BFM #34]

**BFM Access: Read / Write**

This flag is used to avoid the 64DP-M from changing to STOP mode by the PROFIBUS Error "protocol disturbed" (BFM #3 Bit 1). This error can occur when connecting a new device to the PROFIBUS-DP network.

Bit No.	Name	Description	
Bit 0	Mask PROFIBUS Error	OFF (default setting)	If an PROFIBUS error occurs, 64DP-M will set the BFM #29 Bit 8 and detail flags in BFM #3. Then, 64DP-M changes to STOP/Offline mode.
		ON	If the protocol disturbed PROFIBUS Error occurs (BFM #3 Bit 1), 64DP-M will set BFM #3 Bit 1. However, 64DP-M will not set BFM #29 Bit 8, and will not change to STOP mode. If other PROFIBUS Errors occur, 64DP-M will set the BFM #29 Bit 8 and corresponding detail flags in BFM #3. Then, 64DP-M changes to Offline mode.
Bit 1 to 15	Not used		

## 6.19 Number of Allocated Slaves [BFM #38]

**BFM Access: Read Only**

This buffer memory is used to check the number of DP-Slaves connected to the 64DP-M. This value is same as the number of projected DP-Slaves in the GX Configurator-DP.

## 6.20 Operation Service Mode [BFM #39]

**BFM Access: Read / Write**

Sets the Operation Service Mode of the 64DP-M.

If the mode change is not possible, an error is displayed in BFM #29 Bit 12. If an incorrect value for the mode was written to BFM #39, an additional error is displayed in BFM #28 Bit 4.

The mode change can only be performed if the 64DP-M is in STOP mode. Change is not possible from mode 3 to mode 0 when at least one DP-Slave has a input or output data area bigger than 32 byte.

→ For more detailed information on the structure of the I/O Data Area, refer to Section 5.1, 6.23 and 6.24

→ For BFM #28 details, refer to Section 6.12

→ For BFM #29 Bit 12 details, refer to Subsection 6.13.10

Value (Hex)	Description
0	64DP-M is in Normal Service Mode.
3	64DP-M is in Extended Service Mode (default setting).

### Note

Changing the Operation Service Mode by writing to BFM #39 will not permanently change the mode, as the information is only stored in internal RAM memory. After the power supply of the 64DP-M is switched off once, the 64DP-M will startup with the default mode (Operation Service Mode 3).

## 6.21 Data Swap Activate Flag [BFM #73 to #76]

**BFM Access: Read / Write**

These flags use to handle the swap I/O data function for each DP-Slave, which might be helpful when word data are exchanged with DP-Slaves that support different byte orders within a word (little endian / big endian). If this Bit is set to ON the swap function is activated, which means that the transmission order of bytes is swapped for the corresponding DP-Slaves. The default value is set by the GX Configurator-DP.

BFM No.	Bit No.	Station No.	BFM No.	Bit No.	Station No.
BFM #73	Bit 0	1	BFM #75	Bit 0	33
	Bit 1	2		Bit 1	34
	Bit 2	3		Bit 2	35
	⋮	⋮		⋮	⋮
	Bit 15	16		Bit 15	48
BFM #74	Bit 0	17	BFM #76	Bit 0	49
	Bit 1	18		Bit 1	50
	Bit 2	19		Bit 2	51
	⋮	⋮		⋮	⋮
	Bit 15	32		Bit 15	64

### Note

Activating/deactivating these flags by writing to BFM #73 to #76 will not permanently change the configuration that was downloaded to the 64DP-M. After the power supply of the 64DP-M is switched off once, the 64DP-M will startup with the original configuration that is stored in the 64DP-M's internal Flash memory. To make the change permanent, the setting should be done in GX Configurator-DP, or every time on system startup in the user program.

## 6.22 Change Slave FDL Address [BFM #81 to #83]

**BFM Access: Read / Write**

By using the Change Slave FDL Address function, a Slave FDL Address can be changed via 64DP-M in STOP mode (BFM #0 = K0).

To change the Slave FDL Address, write the old (present) Slave FDL Address to BFM #82 and the new Slave FDL Address to BFM #83. Then set the Change Slave FDL Address Flag BFM #81 Bit 0 to ON. After completion of the address change, this flag will automatically change to OFF.

If the change of a Slave FDL Address was not successful, BFM #29 Bit 15 will turn ON.

Write the old (present) FDL address to BFM #82 and the new FDL address to BFM #83 by TO instruction, etc.

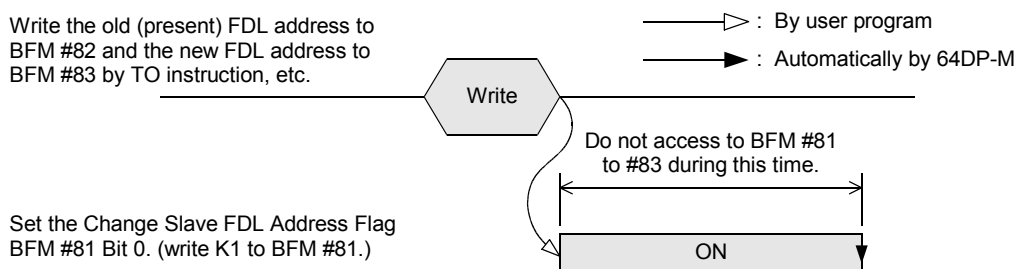

### Note

- When using this function, the DP-Slave must support this function.
- This function effect in STOP mode (BFM #0 = K0). If access to BFM #81 to #83 during #81 Bit 0 is ON, the Slave Change Address Error BFM #29 Bit 15 will occur (turn ON).

1	Introduction
2	Specifications
3	Installation
4	Wiring
5	Mode Data Comms., Global Control
6	Allocation of Buffer Memories (BFMs)
7	Setting Parameters and Configuration
8	Example Program
9	Diagnostics

## 6.23 Cyclic Input Data

Input data areas are used to store cyclic input data from the DP-Slaves on the PROFIBUS-DP network. There are 2 input data formats, Normal Service Mode type (Mode 0) and Extended Service Mode type (Mode 3). These modes can be selected by writing to the operation mode BFM #39.

If the consistency mode flag (BFM #84 to #87) of a DP-Slave is set, the user has to apply the data consistency handling described in Section 5.1.

The 64DP-M has to use Data Consistency Mode to exchange data to DP-Slaves when input data is more than 16 bits. When using the Data Communication Consistency Mode, communication procedure is shown in the following timing chart.

- For operation service mode details, refer to Subsection 5.1.1 and Section 6.20
- For data format detail of Normal Service Mode, refer to Subsection 6.23.3
- For data format detail of Extended Service Mode, refer to Subsection 6.23.4

### 1. Cyclic Input Data Communication

→ For Cyclic output data communication, refer to Section 6.24

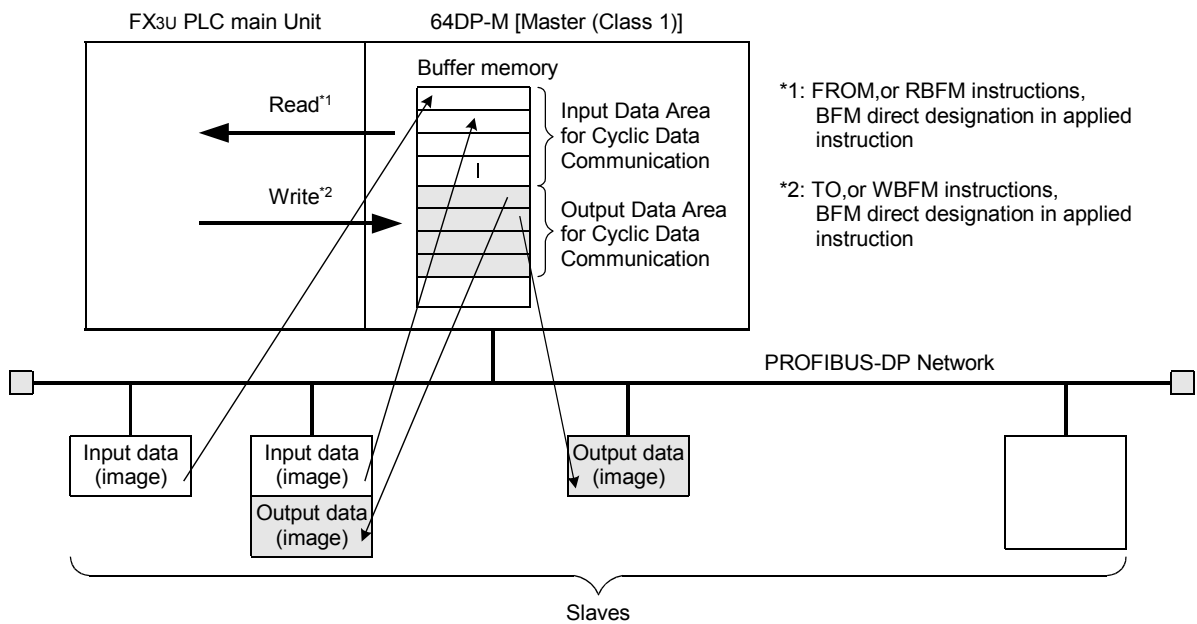

### 2. Cyclic input data reading procedure in consistency mode

When Cyclic Input Data Consistency Activate/Deactivate Flag BFM #84 to #87 is ON for the DP-Slave by setting slave parameter in GX Configurator-DP, the following procedure should be used.

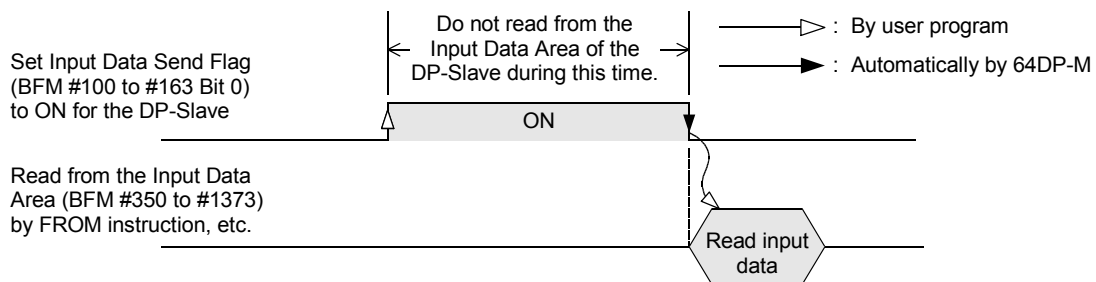



### 6.23.1 Cyclic Input Data Consistency Activate/Deactivate Flags [BFM #84 to #87]

**BFM Access: Read / Write**

These flags are used to handle the data consistency of the Input data. If this Bit is set to ON the handling in Section 5.1 should be used. The default value is set by the GX Configurator-DP. If data consistency greater than 16 bits is set by the GX Configurator-DP, the Bit of this DP-Slave is set to ON. However it can be reset by the user by writing to this BFM.

Cyclic Input Data Consistency Activate/Deactivate Flags of each DP-Slave assignment shows in the following table.

BFM No.	Bit No.	Station No.	BFM No.	Bit No.	Station No.
BFM #84	Bit 0	1	BFM #86	Bit 0	33
	Bit 1	2		Bit 1	34
	⋮	⋮		⋮	⋮
	Bit 15	16		Bit 15	48
BFM #85	Bit 0	17	BFM #87	Bit 0	49
	Bit 1	18		Bit 1	50
	⋮	⋮		⋮	⋮
	Bit 15	32		Bit 15	64

**Note**

Activating/Deactivating these flags by writing to BFM #84 to #87 will not permanently change the configuration that was downloaded to the 64DP-M. After the power supply of the 64DP-M is switched off once, the 64DP-M will startup with the original configuration that is stored in the 64DP-M's internal Flash memory. To make the change permanent, the setting should be done in GX Configurator-DP, or every time on system startup in the user program.

### 6.23.2 Cyclic Input Data Request Flags [BFM #100 to #163]

**BFM Access: Read / Write (only 1 scan)**

Input data request flags should be used for Data Consistency Mode to exchange data to DP-Slaves when input data is more than 16 bits and the consistency mode flag is ON in BFM #84 to #87.

Input data request flag of each DP-Slave assignment shows in the following table.

BFM No.	Bit No.	Station No.	BFM No.	Bit No.	Station No.
BFM #100	Bit 0	1	BFM #132	Bit 0	33
BFM #101	Bit 0	2	BFM #133	Bit 0	34
BFM #102	Bit 0	3	BFM #134	Bit 0	35
⋮	⋮	⋮	⋮	⋮	⋮
BFM #115	Bit 0	16	BFM #147	Bit 0	48
BFM #116	Bit 0	17	BFM #148	Bit 0	49
BFM #117	Bit 0	18	BFM #149	Bit 0	50
BFM #118	Bit 0	19	BFM #150	Bit 0	51
⋮	⋮	⋮	⋮	⋮	⋮
BFM #131	Bit 0	32	BFM #163	Bit 0	64

- 1 Introduction
- 2 Specifications
- 3 Installation
- 4 Wiring
- 5 Mode-Data Comms., Global Control
- 6 Allocation of Buffer Memories (BFMs)
- 7 Setting Parameters and Configuration
- 8 Example Program
- 9 Diagnostics

### 6.23.3 Cyclic Input Data Area in Normal Service Mode [BFM #350 to #1373]

**BFM Access: Read Only**

64DP-M can exchange 32 bytes (16 words) of cyclic input data to every DP-Slave as follows.

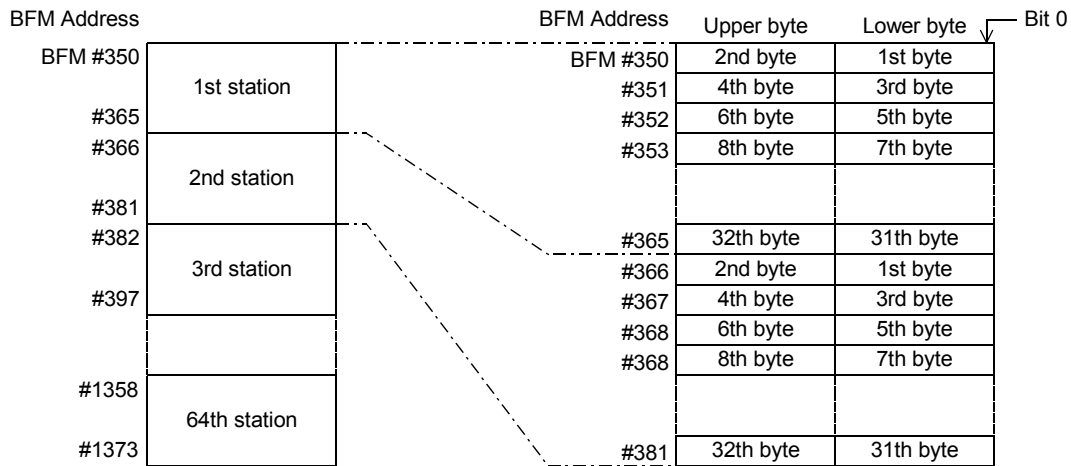

**Note:**

If the input data of a DP-Slave is less than 32 bytes, the input data area of this DP-Slave will be a free area. If the input data of the DP-Slave is more than 32 bytes, the Extended Service Mode is needed.

**Example:**

When the 1st station has 20 bytes of input data, the corresponding input data area has free sectors from 21st to 32nd byte. The value of these free sectors is 0.

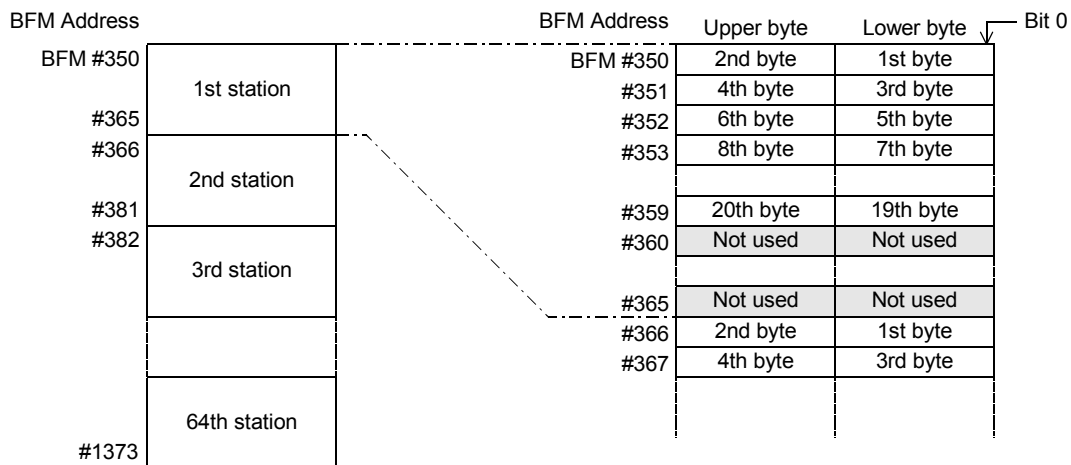

### 6.23.4 Cyclic Input Data Area in Extended Service Mode [BFM #350 to #1373]

**BFM Access: Read Only**

64DP-M can exchange 0 to 244 bytes of I/O data to each of the DP-Slave. Input data length of each DP-Slave assigns according to the parameter file set in the GX Configurator-DP. However, total I/O data for all DP-Slaves is a maximum of 2048/2048 bytes.

**Example:**

An example is shown below where the input data length of the 1st station is 23 bytes and the input data length of the 2nd station is 7 bytes. The free area in the BFM will be filled with 0.

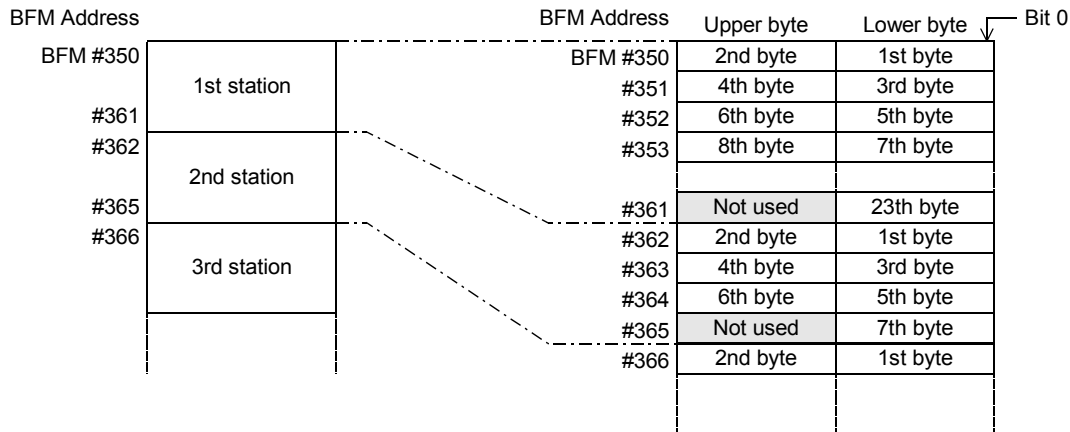

**Note:**

- When the data length is an odd number of bytes, the last upper byte becomes a free area as the 1st byte of station data needs to be assigned as a lower byte, and data for the next station is assigned from the next address.
- When the data length is 0 bytes, the input data area for this station will not be in the input data area.

1	Introduction
2	Specifications
3	Installation
4	Wiring
5	Mode-Data Comms., Global Control
6	Allocation of Buffer Memories (BFMs)
7	Setting Parameters and Configuration
8	Example Program
9	Diagnostics

## 6.24 Cyclic Output Data

Output data areas are used to store cyclic output data to the DP-Slaves on the PROFIBUS-DP network. There are 2 input data formats, Normal Service Mode (Mode 0) and Extended Service Mode (Mode 3). These modes can be selected by writing to the operation mode BFM #39.

If the consistency mode flag (BFM #92 to #95) of a DP-Slave is set, the user has to apply the data consistency handling described in Section 5.1.

The 64DP-M has to use Data Consistency Mode to exchange data to DP-Slaves when output data is more than 16 bits. When using the Data Communication Consistency Mode, communication procedure is shown in the timing chart in the following subsection.

- For operation service mode details, refer to Subsection 5.1.1 and Section 6.20
- For data format detail of Normal Service Mode, refer to Subsection 6.24.3
- For data format detail of Extended Service Mode, refer to Subsection 6.24.4

### Point

Appropriate initial data should be stored in the Cyclic Output Data Area BFM #2350 to #3373 before starting communication.

### 1. Cyclic Output Data Communication

→ For Cyclic input data communication, refer to Section 6.23

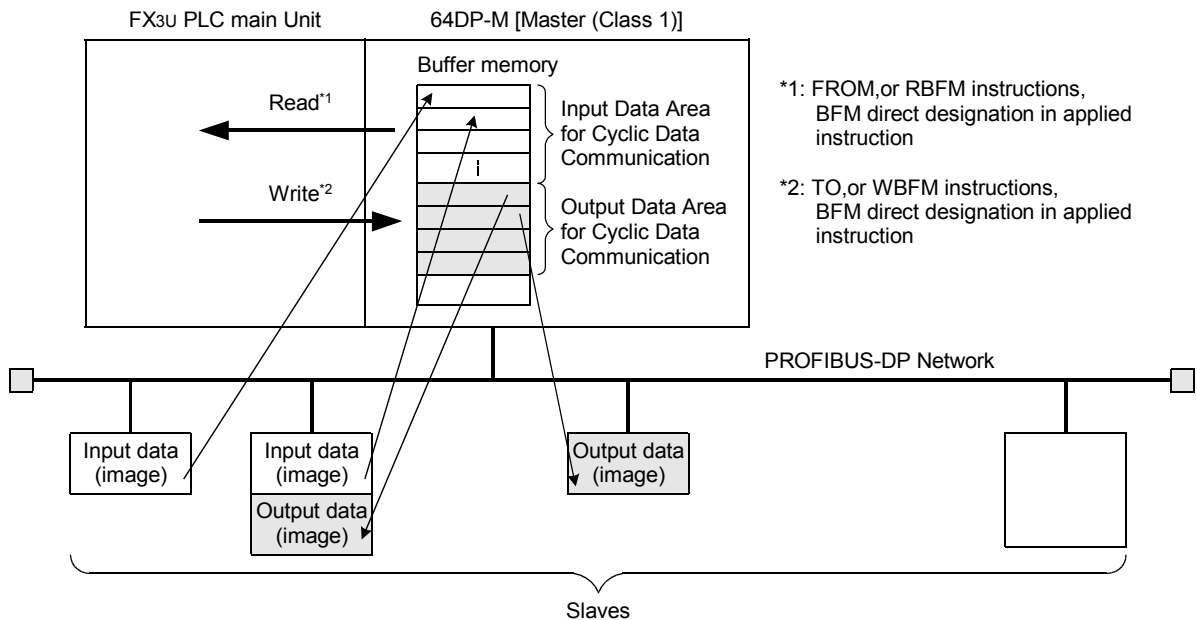

### 2. Cyclic output data sending procedure in consistency mode

When Cyclic Output Data Consistency Activate/Deactivate Flag BFM #92 to #95 is ON for the DP-Slave by setting slave parameter in GX Configurator-DP, the following procedure should be used.

Write the output data of the DP-Slave to the Output Data Area (BFM #2350 to #3373) by TO instruction, etc.

Set Output Data Send Flag (BFM#225 to #288 Bit 0) for the DP-Slave to ON

—▷ : By user program  
—▶ : Automatically by 64DP-M

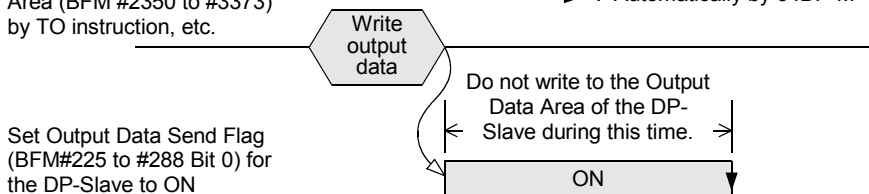

### 6.24.1 Cyclic Output Data Consistency Activate/Deactivate Flags [BFM #92 to #95]

**BFM Access: Read / Write**

These flags are used to handle the data consistency of the Output data. If this Bit is set to ON the handling in Section 5.1 should be used. The default value is set by the GX Configurator-DP. If a data consistency greater than 16 bits is set by the GX Configurator-DP, the Bit of this DP-Slave is set to ON. However it can be reset by the user by writing to this BFM.

Cyclic Output Data Consistency Activate/Deactivate Flags of each DP-Slave assignment is shown in the following table.

BFM No.	Bit No.	Station No.	BFM No.	Bit No.	Station No.
BFM #92	Bit 0	1	BFM #94	Bit 0	33
	Bit 1	2		Bit 1	34
	Bit 2	3		Bit 2	35
	⋮	⋮		⋮	⋮
	Bit 15	16		Bit 15	48
BFM #93	Bit 0	17	BFM #95	Bit 0	49
	Bit 1	18		Bit 1	50
	Bit 2	19		Bit 2	51
	⋮	⋮		⋮	⋮
	Bit 15	32		Bit 15	64

**Note**

Activating / deactivating these flags by writing to BFM #92 to #95 will not permanently change the configuration that was downloaded to the 64DP-M. After the power supply of the 64DP-M is switched off once, the 64DP-M will startup with the original configuration that is stored in the 64DP-M's internal Flash memory. To make the change permanent, the setting should be done in GX Configurator DP, or every time on system startup in the user PLC program.

### 6.24.2 Cyclic Output Data Send Flags [BFM #225 to #288]

**BFM Access: Read / Write**

Output Data Send Flags should be used for Data Consistency Mode to exchange data to DP-Slaves when output data is more than 16 bit and the consistency mode flag is ON in BFM #92 to #95.

Output Data Send Flags of each DP-Slave assignment is shown in the following table.

BFM No.	Bit No.	Station No.	BFM No.	Bit No.	Station No.
BFM #225	Bit 0	1	BFM #257	Bit 0	33
BFM #226	Bit 0	2	BFM #258	Bit 0	34
BFM #227	Bit 0	3	BFM #259	Bit 0	35
⋮	⋮	⋮	⋮	⋮	⋮
BFM #240	Bit 0	16	BFM #272	Bit 0	48
BFM #241	Bit 0	17	BFM #273	Bit 0	49
BFM #242	Bit 0	18	BFM #274	Bit 0	50
BFM #243	Bit 0	19	BFM #275	Bit 0	51
⋮	⋮	⋮	⋮	⋮	⋮
BFM #256	Bit 0	32	BFM #288	Bit 0	64

- 1 Introduction
- 2 Specifications
- 3 Installation
- 4 Wiring
- 5 Mode-Data Comms., Global Control
- 6 Allocation of Buffer Memories (BFMs)
- 7 Setting Parameters and Configuration
- 8 Example Program
- 9 Diagnostics

### 6.24.3 Cyclic Output Data Area in Normal Service Mode [BFM #2350 to #3373]

**BFM Access: Read / Write**

64DP-M can exchange 32 bytes (16 words) of cyclic output data to every DP-Slave as follows.

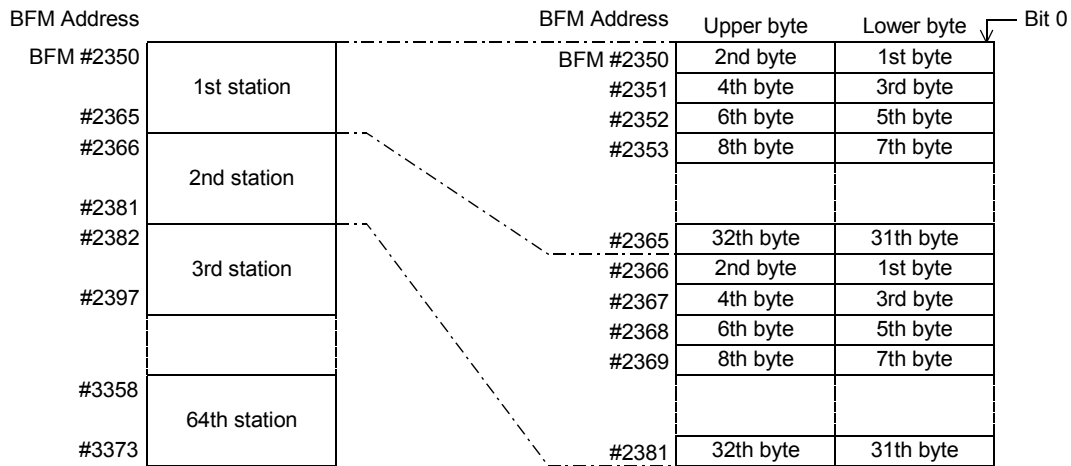

**Note:**

If the output data size of the DP-Slave is less than 32 bytes, then the output data area of this DP-Slave will have a free area. If the output data of the DP-Slave is more than 32 bytes, then the Extended Service Mode needs to be used.

**Example:**

When the 1st station has 20 bytes for output data, the output data area of the 1st station has a free area between the 21st and 32nd byte. The value of this free area is 0.

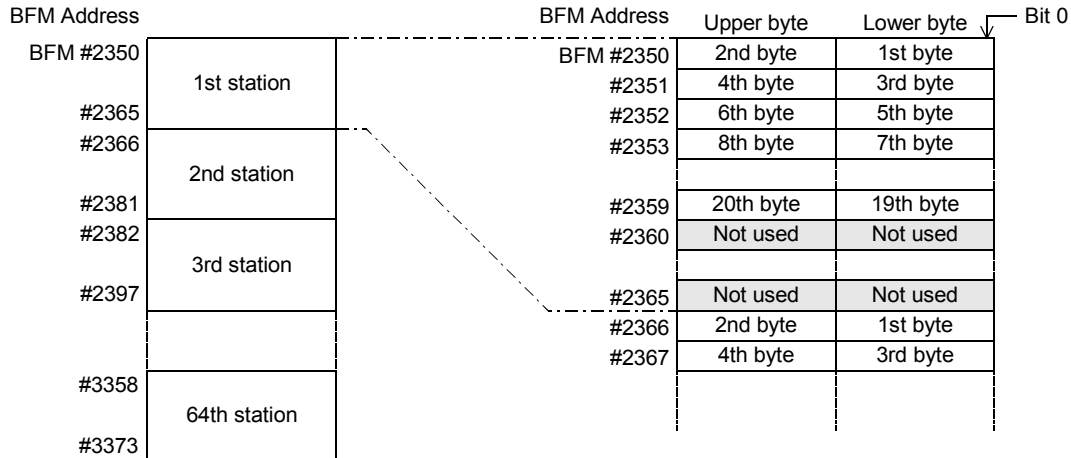

### 6.24.4 Cyclic Output Data Area in Extended Service Mode [BFM #2350 to #3373]

**BFM Access: Read / Write**

64DP-M can exchange 0 to 244 bytes of I/O data to each DP-Slave. The output data length of each DP-Slave is assigned according to the parameter file set in the GX Configurator-DP. However, total I/O data for all DP-Slaves is a maximum of 2048/2048 bytes.

**Example:**

An example is shown below where the output data length of the 1st station is 23 bytes and the output data length of the 2nd station is 7 bytes.

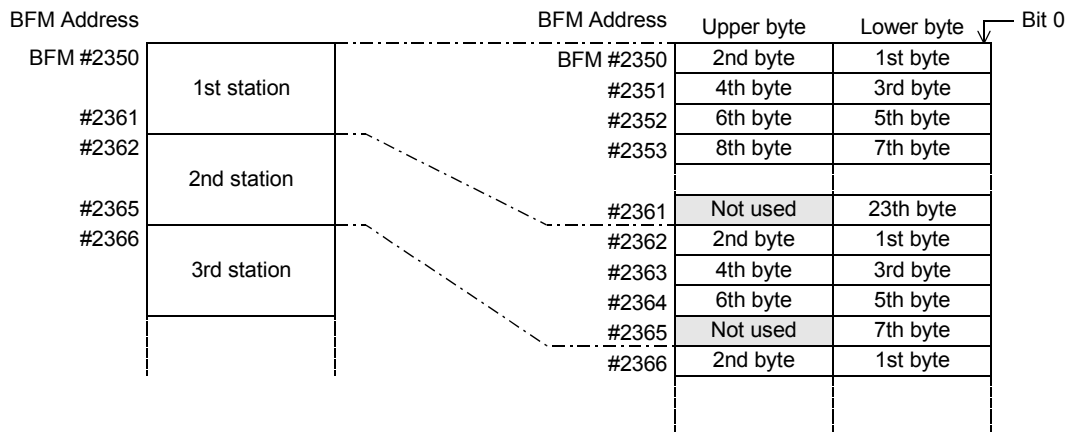

**Note:**

- When the data length is an odd number of bytes, the last upper byte becomes a free area as the 1st byte of the station data needs to be assigned as a lower byte, and data for the next station is assigned from the next address. The value of this free area is 0.
- When the data length is 0 bytes, the output data area for this station will not be in the Output Data Area buffer memory.

1	Introduction
2	Specifications
3	Installation
4	Wiring
5	Mode-Data Comms., Global Control
6	Allocation of Buffer Memories (BFMs)
7	Setting Parameters and Configuration
8	Example Program
9	Diagnostics

## 6.25 Acyclic Input Data

The acyclic communication can be used for setting and change the DP-Slave parameter during cyclic communication. The I/O data channel consists of 244 byte (4 Byte header data and up to 240 Bytes user data). Acyclic data communication has lower communicative priority than cyclic data communication.

The 64DP-M has 4 data areas for acyclic input communication.

The data communication procedure of acyclic input data communication functions according to the following timing chart for communication data consistency.

→ For data format detail, refer to Subsection 6.25.2

### Point

Acyclic I/O data communication can only be used in RUN (BFM #0 = K1), Clear (BFM #0 = K3) or AutoClear (BFM #0 = K4) mode.

→ For mode details, refer to Section 6.2

### 1. Acyclic I/O Data Communication

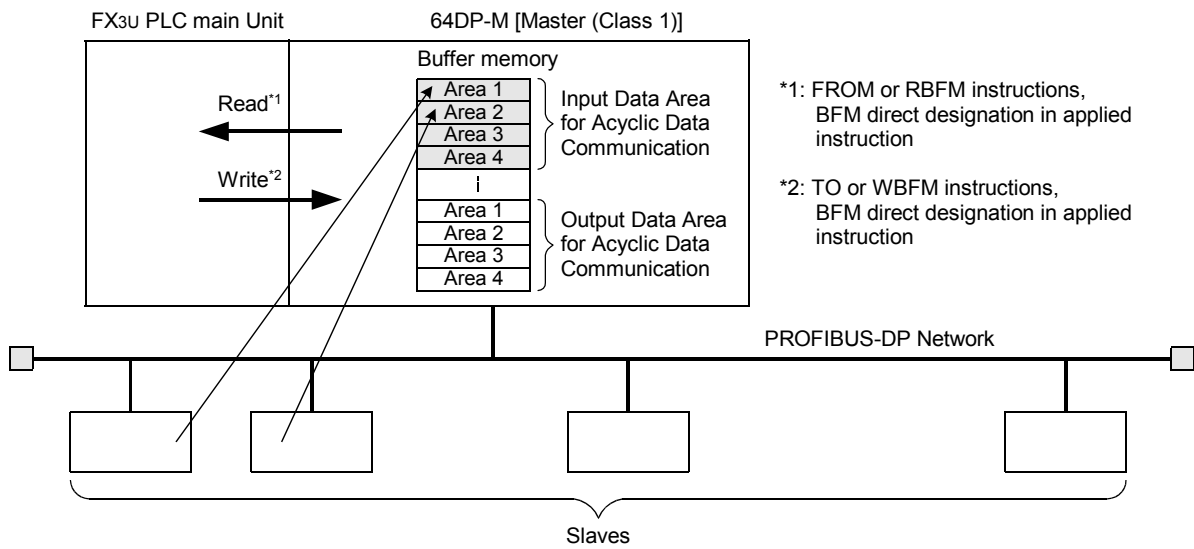

### 2. Acyclic Input Data Communication reading procedure

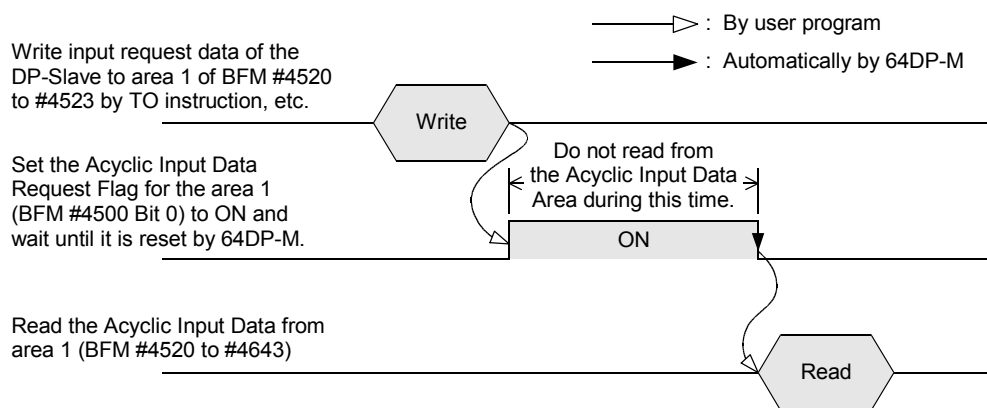



### 6.25.1 Acyclic Input Data Request Flags [BFM #4500 to #4503]

**BFM Access: Read / Write**

Acyclic Input Data Request should be used for getting acyclic input data from the DP-Slaves.  
Acyclic Input Data Request of each data area assignment is shown in the following table.

BFM No.	Bit No.	Description	Acyclic Input Data Area	
			Header	Data
BFM #4500	Bit 0	Acyclic Input Data Request Flag for data area 1	BFM #4520 to #4523	BFM #4524 to #4643
	Bit 1 to 15	Not used	-	-
BFM #4501	Bit 0	Acyclic Input Data Request Flag for data area 2	BFM #4644 to #4647	BFM #4648 to #4767
	Bit 1 to 15	Not used	-	-
BFM #4502	Bit 0	Acyclic Input Data Request Flag for data area 3	BFM #4768 to #4771	BFM #4772 to #4891
	Bit 1 to 15	Not used	-	-
BFM #4503	Bit 0	Acyclic Input Data Request Flag for data area 4	BFM #4892 to #4895	BFM #4896 to #5015
	Bit 1 to 15	Not used	-	-

### 6.25.2 Acyclic Input Data Area [BFM #4520 to #5015]

**BFM Access: Read / Write**

64DP-M has 4 data areas of 248 bytes for Acyclic Input Data via communication channels.  
Acyclic Input Data format of each data area assignment is shown in the following table.

BFM No.				Name	Description
Data Area 1	Data Area 2	Data Area 3	Data Area 4		
BFM #4520	BFM #4644	BFM #4768	BFM #4892	SlaveNumber <sup>*1</sup>	<ul style="list-style-type: none"> <li>When writing request data Writes the projected slave number for reading. The valid range lies between 1 and 64 (slaves).</li> <li>When reading data Shows the projected slave number. The valid range lies between 1 and 64 (slaves).</li> </ul>
BFM #4521	BFM #4645	BFM #4769	BFM #4893	SlotNumber <sup>*1</sup>	<ul style="list-style-type: none"> <li>When writing request data Writes the slot number for reading. This number is defined by the addressing for acyclic services.</li> <li>When reading data Shows the slot number. This number is defined by the addressing for acyclic services.</li> </ul>
BFM #4522	BFM #4646	BFM #4770	BFM #4894	Index <sup>*1</sup>	<ul style="list-style-type: none"> <li>When writing request data Writes the index value.</li> <li>When reading data Shows the index value of the data</li> </ul>
BFM #4523	BFM #4647	BFM #4771	BFM #4895	Length <sup>*1</sup>	<ul style="list-style-type: none"> <li>When writing request data Writes the data length for reading. The valid range lies between 1 and 240 (bytes).</li> <li>When reading data Shows the data length of the read data. The valid range lies between 1 and 240 (bytes).</li> </ul>
BFM #4524 to #4643	BFM #4648 to #4767	BFM #4772 to #4891	BFM #4896 to #5015	Data[ ] <sup>*2</sup>	User data → <b>For data format details, refer to the manual of DP-Slave</b>

\*1. One byte is written to one separate BFM, except for the Data field

\*2. Size of Data[ ] is 240 bytes.

## 6.26 Acyclic Output Data

The acyclic communication can be used for setting and change the DP-Slave parameter during cyclic communication. The I/O data channel consists of 244 byte (4 Byte header data and up to 240 Bytes user data). Acyclic data communication has lower communicative priority than cyclic data communication.

The 64DP-M has 4 data areas for acyclic output communication.

The data communication procedure of acyclic I/O data communication functions according to the following timing chart for communication data consistency.

→ For data format detail, refer to Subsection 6.26.2

### Point

Acyclic I/O data communication can only be used in RUN (BFM #0 = K1), Clear (BFM #0 = K3) or AutoClear (BFM #0 = K4) mode.

→ For mode details, refer to Section 6.2

### 1. Acyclic I/O Data Communication

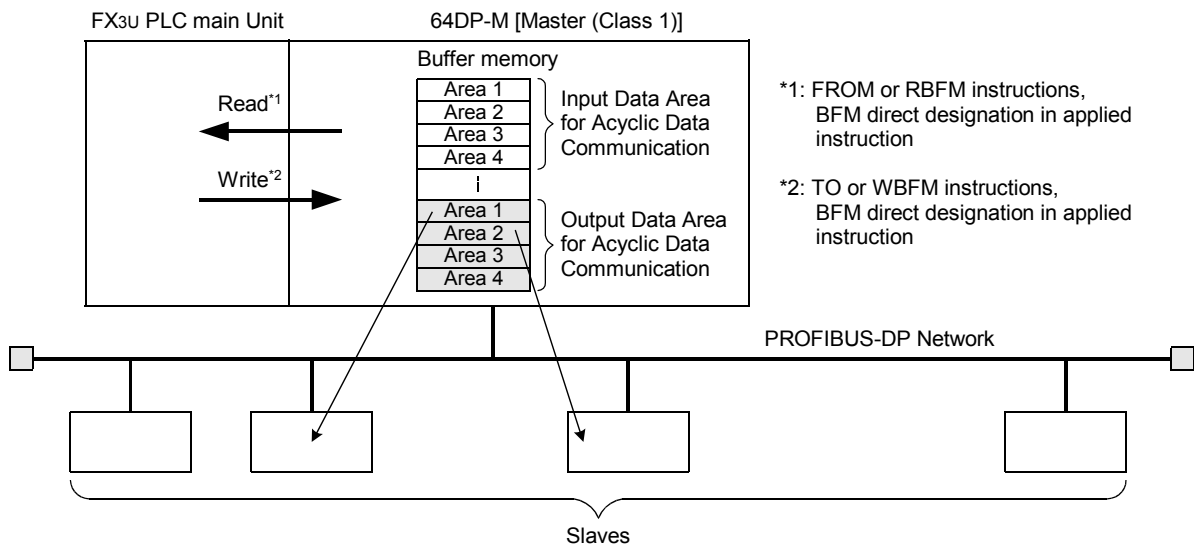

### 2. Acyclic Output Data Sending procedure

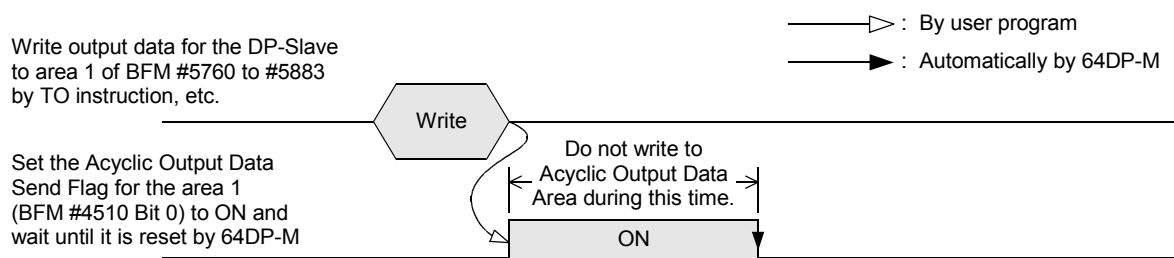

### 6.26.1 Acyclic Output Data Send Flags [BFM #4510 to #4513]

**BFM Access: Read / Write**

Acyclic Output Data Send Flag should be used for sending acyclic output data to the DP-Slaves. Acyclic Output Data Send Flag of each channel assignment shows in the following table.

BFM No.	Bit No.	Description	Acyclic Input Data Area	
			Header	Data
BFM #4510	Bit 0	Acyclic Output Data Send Flag for data area 1	BFM #5760 to #5763	BFM #5764 to #5883
	Bit 1 to 15	Not used	-	-
BFM #4511	Bit 0	Acyclic Output Data Send Flag for data area 2	BFM #5884 to #5887	BFM #5888 to #6007
	Bit 1 to 15	Not used	-	-
BFM #4512	Bit 0	Acyclic Output Data Send Flag for data area 3	BFM #6008 to #6011	BFM #6012 to #6131
	Bit 1 to 15	Not used	-	-
BFM #4513	Bit 0	Acyclic Output Data Send Flag for data area 4	BFM #6132 to #6135	BFM #6136 to #6255
	Bit 1 to 15	Not used	-	-

### 6.26.2 Acyclic Output Data Area [BFM #5760 to #6255]

**BFM Access: Read / Write**

64DP-M has 4 data areas of 248 bytes for Acyclic Output Data via communication channels. The Acyclic Output Data format of each data area assignment is shown in the following table.

BFM No.				Name	Description
Data Area 1	Data Area 2	Data Area 3	Data Area 4		
BFM #5760	BFM #5884	BFM #6008	BFM #6132	SlaveNumber* <sup>1</sup>	Destination slave number. The valid range lies between 1 and 64 (slaves).
BFM #5761	BFM #5885	BFM #6009	BFM #6133	SlotNumber* <sup>1</sup>	Destination slot number. This number is defined by the addressing for acyclic services.
BFM #5762	BFM #5886	BFM #6010	BFM #6134	Index* <sup>1</sup>	Index value for sending data
BFM #5763	BFM #5887	BFM #6011	BFM #6135	Length* <sup>1</sup>	Length of user data. The valid range lies between 1 and 240 (bytes).
BFM #5764 to #5883	BFM #5888 to #6007	BFM #6012 to #6131	BFM #6136 to #6255	Data[ ]* <sup>2</sup>	User data → For data format details, refer to the manual of DP-Slave

\*1. One byte is written to one separate BFM, except for the Data field

\*2. Size of Data[ ] is 240 bytes.

## 6.27 Master/Slave Internal Slave Parameter Error Flags [BFM #7000 to #7003]

**BFM Access: Read / Write (only reset to 0)**

Shows Master/Slave Internal Parameter Error status of each DP-Slave. If the Bit is ON there is a Master/Slave Internal Parameter problem with this DP-Slave.

If any of these Bits is ON, the corresponding Bit in BFM #29 Bit 3 will also be ON. Resetting BFM #29 Bit 3 will clear BFM #7000 to #7003 to K0.

Master/Slave Internal Parameter Error Flags of each DP-Slave assignment is shown in the following table.

BFM No.	Bit No.	Station No.	BFM No.	Bit No.	Station No.
BFM #7000	Bit 0	1	BFM #7002	Bit 0	33
	Bit 1	2		Bit 1	34
	⋮	⋮		⋮	⋮
	Bit 15	16		Bit 15	48
BFM #7001	Bit 0	17	BFM #7003	Bit 0	49
	Bit 1	18		Bit 1	50
	⋮	⋮		⋮	⋮
	Bit 15	32		Bit 15	64

## 6.28 Master/Slave Internal Slave Parameter Error Data [BFM #7008 to #7071]

**BFM Access: Read Only**

For each DP-Slave there is a Master/Slave Parameter Error Data implemented with the following error codes. If any of these Bits is ON, the corresponding Bit in BFM #29 Bit 3 and in BFM #7000 to #7003 will also be ON. Resetting BFM #29 Bit 3 will clear BFM #7000 to #7003 and BFM #7008 to #7071 to K0.

Bit No.	Name	Description
Bit 0	Cyclic Output Data Error	Slave FDL Address is invalid.
Bit 1	Cyclic Input Data Error	DP-Slave does not participate in cyclic data exchange
Bit 2	Cyclic Input Data Error	Slave FDL Address is invalid.
Bit 3	Parameter / Configuration Download	Loading of a Slave parameter set has failed.
Bit 4	Get Slave Diagnostic	The Slave FDL Address is invalid or the DP-Slave has not been activated.
Bit 5	Not Used	
Bit 6	Get Alarm Message	Slave FDL Address is invalid or the DP-Slave has not been activated.
Bit 7	Get Alarm Message	No alarms available
Bit 8	Alarm Acknowledge	<ul style="list-style-type: none"> <li>There are no alarms to be acknowledged matching the sequence number.</li> <li>There is no alarm of this type to be acknowledged.</li> <li>There is no alarm to be acknowledged since the alarms are disabled for this DP-Slave.</li> </ul>
Bit 9	Not Used	
Bit 10	Acyclic Input Data Error	On by all errors
Bit 11	Acyclic Input Data Error	<ul style="list-style-type: none"> <li>Service blocked by the partner station</li> <li>The DP-Slave has deactivated this service.</li> </ul>
Bit 12	Acyclic Input Data Error	Wrong request parameter
Bit 13	Acyclic Output Data Error	On by all errors
Bit 14	Acyclic Output Data Error	Service blocked by the partner station
Bit 15	Acyclic Output Data Error	Wrong request parameter

## 6.29 Slave Diagnostic Information

The 64DP-M can directly read the current Slave Diagnostic Information from the selected DP-Slave by BFM #7209 to BFM #7210 to #7335. For reading current Slave Diagnostic Information procedure, see the following timing chart.

### Point

This function can only be used in RUN (BFM #0 = K1), Clear (BFM #0 = K3) or AutoClear (BFM #0 = K4) mode.

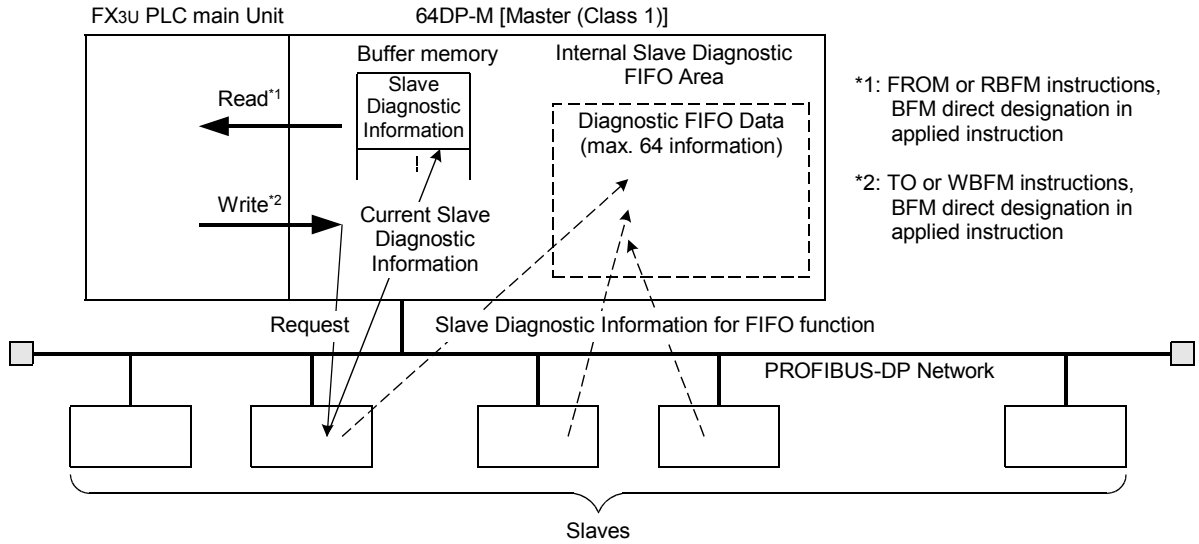

### Current Slave Diagnostic Information reading procedure:

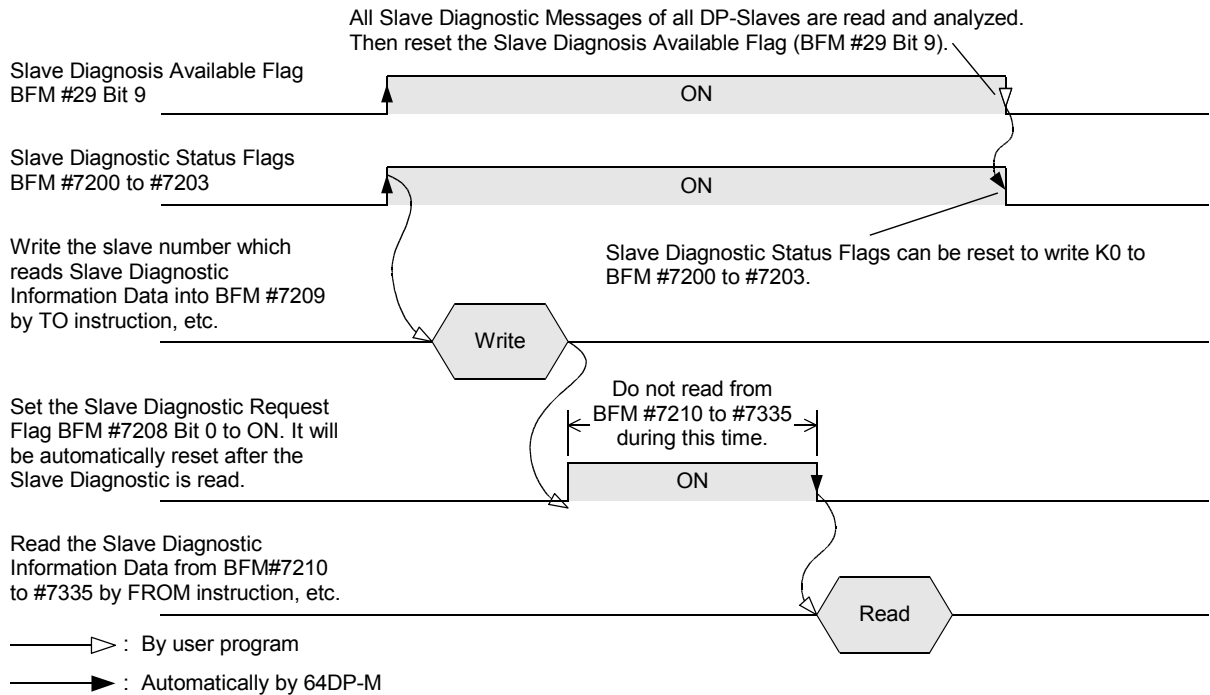

1	Introduction
2	Specifications
3	Installation
4	Wiring
5	Mode Data Comms., Global Control
6	Allocation of Buffer Memories (BFMs)
7	Setting Parameters and Configuration
8	Example Program
9	Diagnostics

### 6.29.1 Slave Diagnostic Status Flags [BFM #7200 to #7203]

**BFM Access: Read / Write (only reset to 0)**

Slave Diagnostic Status Flags show which DP-Slaves have sent Slave Diagnostic Information. If the Bit is ON the DP-Slave has sent a Slave Diagnostic Information.

If any of these Bits are ON, the corresponding Bit in BFM #29 Bit 9 will also be ON. Resetting BFM #29 Bit 9 will clear BFM #7200 to #7203 to K0.

→ For Slave Diagnostic Available Flag details, refer to Subsection 6.13.8

→ For Slave Diagnostic Information Data format, refer to Subsection 6.29.4

Slave Diagnostic Status Flags for each DP-Slave assignment are shown in the following table.

BFM No.	Bit No.	Station No.	BFM No.	Bit No.	Station No.
BFM #7200	Bit 0	1	BFM #7202	Bit 0	33
	Bit 1	2		Bit 1	34
	Bit 2	3		Bit 2	35
	⋮	⋮		⋮	⋮
	Bit 15	16		Bit 15	48
BFM #7201	Bit 0	17	BFM #7203	Bit 0	49
	Bit 1	18		Bit 1	50
	Bit 2	19		Bit 2	51
	⋮	⋮		⋮	⋮
	Bit 15	32		Bit 15	64

### 6.29.2 Slave Diagnostic Request [BFM #7208]

**BFM Access: Read / Write (only 1 scan)**

Set to ON (write K1 to BFM #7208) when Slave Diagnostic Information of DP-Slave specified by BFM #7209 shall be read.

When the Slave Diagnostic Information is available in BFM #7210 to #7335, this flag will be reset.

Slave Diagnostic Request Flag assignment is shown in the following table.

Bit No.	Description
Bit 0	Slave Diagnostic Request Flag
Bit 1 to 15	Not used

### 6.29.3 Request Slave Number [BFM #7209]

**BFM Access: Read / Write**

Writes to slave number which stores the current Slave Diagnostic Information to BFM #7210 to #7335.

The valid range lies between 1 and 64 (slaves).

## 6.29.4 Slave Diagnostic Information Data [BFM #7210 to #7335]

**BFM Access: Read Only**

Reads the current Slave Diagnostic Information from BFM #7210 to #7335.

Data format of the Slave Diagnostic Information is as follows (One byte is written to one separate BFM, except for the ExtDiagData field). Details of each are shown below.

BFM No.	Description
BFM #7210	SlaveAddress
BFM #7211	StationStatus1
BFM #7212	StationStatus2
BFM #7213	StationStatus3
BFM #7214	MasterAddress
BFM #7215	IdentNumber
BFM #7216	Length
BFM #7217 to #7335	ExtDiagData [238 byte]

### 1. SlaveAddress

Slave address whose diagnosis state has been read.  
The valid range lies between 0 and 125.

### 2. StationStatus1

Bit No.	Description
Bit 0	This bit is set by the 64DP-M if the DP-Slave can no longer be reached via the bus.
Bit 1	The DP-Slave cannot supply any valid input data. The 64DP-M fetches diagnoses until this Bit is reset by the DP-Slave.
Bit 2	The comparison of the configuration data transferred by the 64DP-M with the actual configuration data of the DP-Slave has failed. The DP-Slave waits for a new configuration.
Bit 3	If this Bit is set, the diagnostic data will receive additional information in the ExtDiagData. This data is vendor specific.
Bit 4	This Bit is set by the DP-Slave if functionality requested in the parameterization data is not supported.
Bit 5	The 64DP-M sets this flag if it has received an implausible response from the DP-Slave.
Bit 6	If the last parameterization data of the 64DP-M was incorrect, e.g. wrong identification mark. The DP-Slave requests new parameterization data.
Bit 7	This Bit is set by the 64DP-M if the master FDL address in the diagnosis data does not correspond to the actual station address or contains a invalid master FDL address (0xFF).

1

Introduction

2

Specifications

3

Installation

4

Wiring

5

Mode-Data Comms., Global Control

6

Allocation of Buffer Memories (BFMs)

7

Setting Parameters and Configuration

8

Example Program

9

Diagnostics

### 3. StationStatus2

Bit No.	Description
Bit 0	Parameterization of the DP-Slave has not yet been performed or has failed. The DP-Slave waits for new parameterization data from the 64DP-M.
Bit 1	The DP-Slave cannot supply any valid input data. The 64DP-M fetches diagnoses until this Bit is reset by the DP-Slave. During this time, there is no exchange of process data.
Bit 2	This Bit is fixed to ON by the DP-Slave.
Bit 3	With this flag, the DP-Slave indicates that its watchdog timer is active. If it receives no valid message from the 64DP-M during this time, it will leave the transmission of cyclic data and go into the fail-safe state.
Bit 4	The DP-Slave sets this Bit as soon as it has received the FREEZE control command from the 64DP-M. Control commands are transferred by the Global Control service.
Bit 5	The DP-Slave sets this Bit as soon as it has received the SYNC control command from the 64DP-M. Control commands are transferred with the Global Control service.
Bit 7	This flag is set by the 64DP-M if a DP-Slave has been labelled as deactivated in the parameter set or has been removed from cyclic processing.

### 4. StationStatus3

Bit No.	Description
Bit 0 to 6	Not used
Bit 7	This Bit can be influenced both by the 64DP-M and by the DP-Slave: The 64DP-M sets it if the DP-Slave sends more diagnostic information than the 64DP-M can store in its diagnosis buffer. The DP-Slave application sets this Bit if there are more diagnosis information than the DP-Slave can process, even by repeated diagnosis information.

### 5. MasterAddress

Station address of the 64DP-M which has parameterized the DP-Slave.

If the DP-Slave has not yet been parameterized, the master FDL address will receive the value.

### 6. IdentNumber

A DP-Slave is uniquely identified by the identification mark.

### 7. Length

Length of the diagnostic data.

### 8. ExtDiagData[ ]

In this data, the DP-Slave can store additional vendor-specific diagnosis information. Block structures are defined for device-, identifier- and channel-related diagnosis information.

#### 1) Device-related diagnosis (DPV0)

The block for device-related diagnosis consists of a header byte and a variable number of bytes with general device-specific diagnosis information, such as excess temperature, under- or overvoltage. The coding is device specific. For further evaluation, the IdentNumber and the GSD must be used.

ExtDiagData[0]: Bit 0 to 5 = Block length including header  
if value = 63 then 62 bytes of diagnosis follows

Bit 6 = 0

Bit 7 = 0



## 2) Identifier-related diagnosis (module diagnosis)

The block for identifier-related diagnosis consists of a header byte and a variable number of bytes with identifier-related diagnostic information. One bit is reserved for each identifier byte assigned during configuration. The bit structure is always filled up to the byte limit; non-configured bits are to be assigned as zero. A set bit indicates that diagnosis data are present in this I/O area; the type of diagnosis is not indicated. The order defined during configuration must be maintained.

ExtDiagData[0]:	Bit 0 to 5	= Block length including header if value = 63 then 62 bytes of diagnosis follows
	Bit 6	= 1
	Bit 7	= 0
ExtDiagData[1]:	Bit 0	= 1: Module 1 has diagnosis
	Bit 1	= 1: Module 2 has diagnosis
	Bit 2	= 1: Module 3 has diagnosis
	⋮	⋮
ExtDiagData[2]:	Bit 0	= 1: Module 9 has diagnosis
	Bit 1	= 1: Module 10 has diagnosis
	Bit 2	= 1: Module 11 has diagnosis
	⋮	⋮

## 3) Channel-related diagnosis

In this block, the diagnosed channels and the reason for diagnosis are entered consecutively. The length of each entry is three bytes.

Identifier number:

ExtDiagData[0]:	Bit 0 to 5	= Module number 0 to 63
	Bit 6	= 0
	Bit 7	= 1
ExtDiagData[1]:	Bit 0 to 5	= Channel number 0 to 63
	Bit 6	= 1: Input channel
	Bit 7	= 1: Output channel
ExtDiagData[2]:	Bit 0 to 4	= 0: Reserved
	Bit 0 to 4	= 1: Short circuit
	Bit 0 to 4	= 2: Undervoltage
	Bit 0 to 4	= 3: Overvoltage
	Bit 0 to 4	= 4: Overload
	Bit 0 to 4	= 5: Excess temperature
	Bit 0 to 4	= 6: Cable break
	Bit 0 to 4	= 7: Upper limit value exceeded
	Bit 0 to 4	= 8: Lower limit value exceeded
	Bit 0 to 4	= 9: Error
	Bit 0 to 4	= 10 to 15: Reserved
	Bit 0 to 4	= 16 to 31: Vendor-specific
	Bit 5 to 7	= 1: Channel -Type* <sup>1</sup> 1 Bit error
	Bit 5 to 7	= 2: Channel -Type* <sup>1</sup> 2 Bit error
	Bit 5 to 7	= 3: Channel -Type* <sup>1</sup> 4 Bit error
	Bit 5 to 7	= 4: Channel -Type* <sup>1</sup> 1 Byte error
	Bit 5 to 7	= 5: Channel -Type* <sup>1</sup> 1 Word error
	Bit 5 to 7	= 6: Channel -Type* <sup>1</sup> 2 Word error
ExtDiagData[3]:	Bit 0 to 5	= Module number 0 to 63
	Bit 6	= 0
	Bit 7	= 1

ExtDiagData[4]:	Bit 0 to 5	= Channel number 0 to 63
	Bit 6	= 1: Input channel
	Bit 7	= 1: Output channel
ExtDiagData[5]:	Bit 0 to 4	= 0: Reserved
	Bit 0 to 4	= 1: Short circuit
	Bit 0 to 4	= 2: Undervoltage
	Bit 0 to 4	= 3: Overvoltage
	Bit 0 to 4	= 4: Overload
	Bit 0 to 4	= 5: Excess temperature
	Bit 0 to 4	= 6: Cable break
	Bit 0 to 4	= 7: Upper limit value exceeded
	Bit 0 to 4	= 8: Lower limit value exceeded
	Bit 0 to 4	= 9: Error
	Bit 0 to 4	= 10 to 15: Reserved
	Bit 0 to 4	= 16 to 31: Vendor-specific
	Bit 5 to 7	= 1: Channel -Type*1 1 Bit error
	Bit 5 to 7	= 2: Channel -Type*1 2 Bit error
	Bit 5 to 7	= 3: Channel -Type*1 4 Bit error
	Bit 5 to 7	= 4: Channel -Type*1 1 Byte error
	Bit 5 to 7	= 5: Channel -Type*1 1 Word error
	Bit 5 to 7	= 6: Channel -Type*1 2 Word error
	⋮	⋮

\*1. The channel type is only used for diagnosis and has no influence on the identifiers or modules from the configuration data.

## 6.30 Diagnostic Information FIFO

The 64DP-M can stack the Slave Diagnostic Information to a maximum of 64 entries in the Internal Diagnostic FIFO Area for all DP-Slaves. The Slave Diagnostic Information which enters this Internal Diagnostic FIFO Area can be read (stored) in BFM #7338 to #7463 one by one (the oldest entry will be read at first). For the procedure on reading Slave Diagnostic Information, see the following timing chart.

Moreover, after stocking up to 64 Slave Diagnostic entries in the Internal Diagnostic FIFO Area, new Slave Diagnostic Information is not stocked until "Diagnostic FIFO is Full" flag BFM #29 Bit 13 is OFF.

→ For "Diagnostic FIFO is Full" flag BFM #29 Bit 13, refer to Subsection 6.13.12

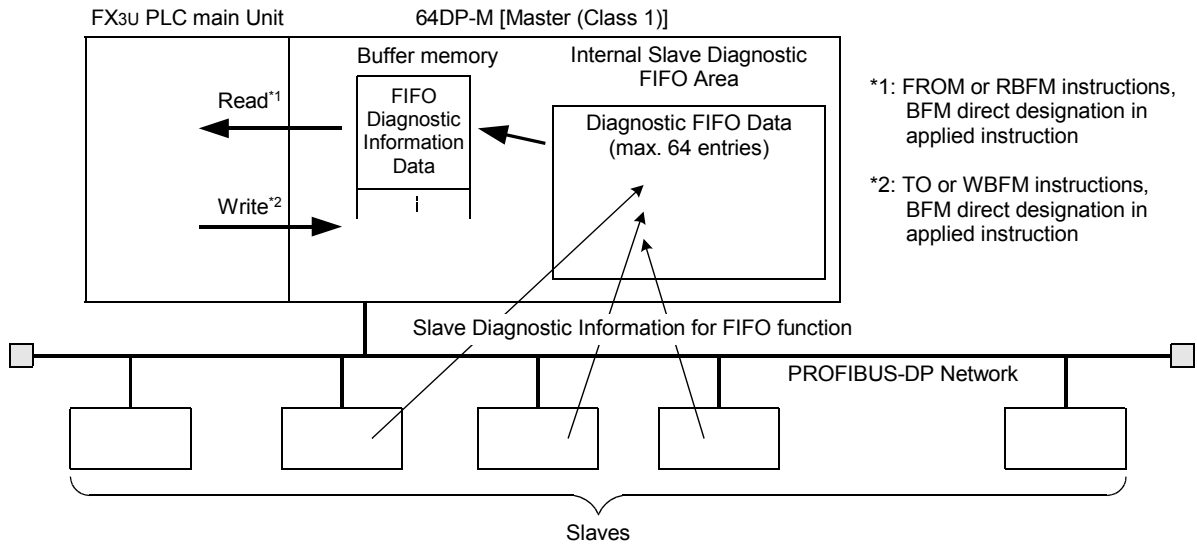

### FIFO Slave Diagnostic Information Data reading procedure:

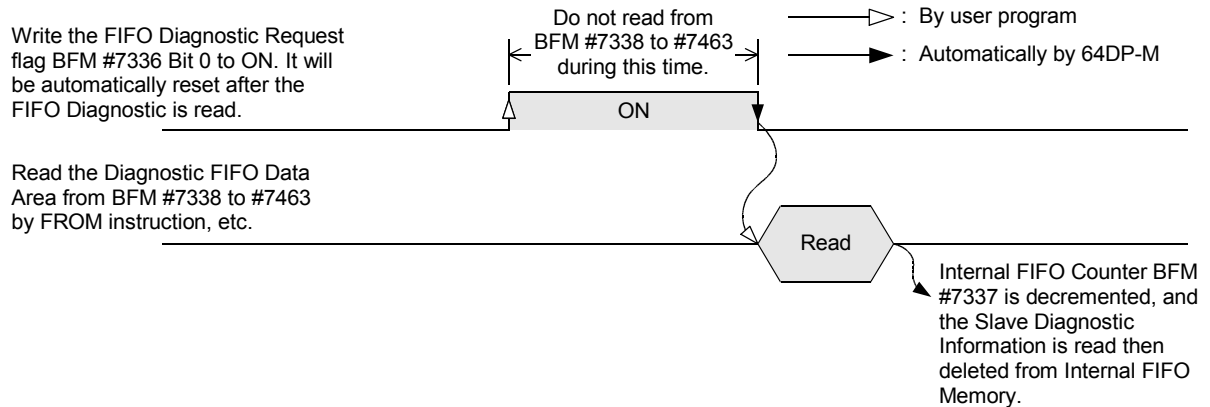

### Note

The FIFO Slave Diagnostic Information can be cleared by one of the following 3 methods:

- Change mode from STOP to RUN. (Changes value in BFM #1 from K0 to K1)
- Reset (Clear) Internal FIFO Counter BFM #7337. (Writes K0 to BFM #7337)
- Reset Diagnostic FIFO Full flag BFM #29 Bit 13 when this bit is ON.

When it is a problem that all FIFO Diagnostic Information is cleared in one step, read out the information one by one, from BFM #7336 to #7463, until the Internal FIFO Counter BFM #7337 becomes 0, and BFM #29 Bit 13 will be reset automatically.

1	Introduction
2	Specifications
3	Installation
4	Wiring
5	Mode-Data Comms., Global Control
6	Allocation of Buffer Memories (BFMs)
7	Setting Parameters and Configuration
8	Example Program
9	Diagnostics

### 6.30.1 FIFO Diagnostic Request [BFM #7336]

**BFM Access: Read / Write (only 1 scan)**

Set ON (write K1 to BFM #7336) to read a Slave Diagnostic Information from the Internal Slave Diagnostic FIFO. When BFM #7336 is set ON, the oldest Diagnostic Information is moved from the FIFO to BFM #7338 to #7463. After moving of the information, the flag is automatically reset. FIFO Diagnostic Request Flag assignment shows in the following table.

Bit No.	Description
Bit 0	Slave Diagnostic Request Flag
Bit 1 to 15	Not used

### 6.30.2 Internal FIFO Counter [BFM #7337]

**BFM Access: Read / Write**

This value is the number of stocked Slave Diagnostic Information in Internal Diagnostic FIFO Area. 64DP-M can stock up to 64 information in Internal Diagnostic FIFO Area.

**Note**

When writing K0 to BFM #7337, all FIFO Slave Diagnostic Information will be cleared from the Internal Diagnostic FIFO Area.

### 6.30.3 Diagnostic FIFO Data Area [BFM #7338 to #7463]

**BFM Access: Read Only**

Read the Diagnostic FIFO Information from BFM #7338 to #7463. Data format of Slave Diagnostic Information shows the following (One byte is written to one separate BFM, except for the ExtDiagData field). Details of each data are shown below.

→ For details of **StationStatus1**, **StationStatus2**, **StationStatus3**, **MasterAddress**, **IdentNumber**, **ExtDiagData**, refer to Subsection 6.29.4

BFM No.	Description
BFM #7338	SlaveAddress
BFM #7339	StationStatus1
BFM #7340	StationStatus2
BFM #7341	StationStatus3
BFM #7342	MasterAddress
BFM #7343	IdentNumber
BFM #7344	Length
BFM #7345 to #7463	ExtDiagData [238 byte]

**1. SlaveAddress**

Address of the DP-Slave whose diagnosis state has been read. The valid range lies between 0 and 125 slaves.

**2. Length**

Length of the diagnostic data.

## 6.31 Slave Diagnostic Status Data [BFM #7464 to #7591]

**BFM Access: Read Only**

This BFM Area shows an overview over the PROFIBUS diagnosis of each DP-Slave. This BFM area is updated continuously while the 64DP-M is in RUN mode.

BFM No.	Station No.	High byte	Low byte
BFM #7464	1	Station Status 3	Slave FDL address
BFM #7465		Station Status 1	Station Status 2
BFM #7466	2	Station Status 3	Slave FDL address
BFM #7467		Station Status 1	Station Status 2
BFM #7468	3	Station Status 3	Slave FDL address
BFM #7469		Station Status 1	Station Status 2
BFM #7470	4	Station Status 3	Slave FDL address
BFM #7471		Station Status 1	Station Status 2
⋮	⋮	⋮	⋮
BFM #7590	64	Station Status 3	Slave FDL address
BFM #7591		Station Status 1	Station Status 2

<b>1</b>	Introduction
<b>2</b>	Specifications
<b>3</b>	Installation
<b>4</b>	Wiring
<b>5</b>	Mode-Data Comms., Global Control
<b>6</b>	Allocation of Buffer Memories (BFMs)
<b>7</b>	Setting Parameters and Configuration
<b>8</b>	Example Program
<b>9</b>	Diagnostics

## 6.32 Alarm Message

The 64DP-M can handle Alarm Messages from the PROFIBUS-DPV1 slaves (alarm model). The Alarm Message can be read by the following procedure.

When receiving an Alarm Message from the DP-Slave, 64DP-M should acknowledge this Alarm Message to the DP-Slave. If 64DP-M does not acknowledge, the DP-Slave can send maximum 2 alarm messages.

For acknowledging procedure and Alarm Message reading procedure, see following time chart.

### Note

This function can only be used in RUN (BFM #0 = K1), Clear (BFM #0 = K3) or AutoClear (BFM #0 = K4) mode.

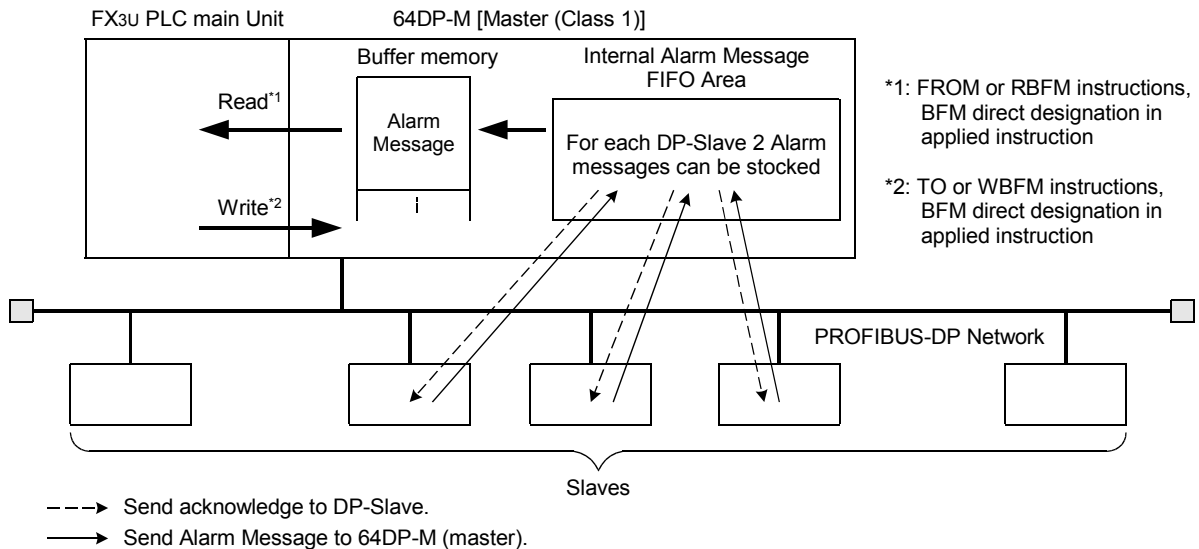

### 1. Alarm Message reading procedure by Automatic Acknowledge Function;

→ For Slave Alarm Message Available, refer to Subsection 6.13.9

→ For Automatical Acknowledge Setting, Alarm Acknowledge Status, Alarm Message Request, Request Slave Number, Alarm Message Data, refer to Subsection 6.32.2 to 6.32.7

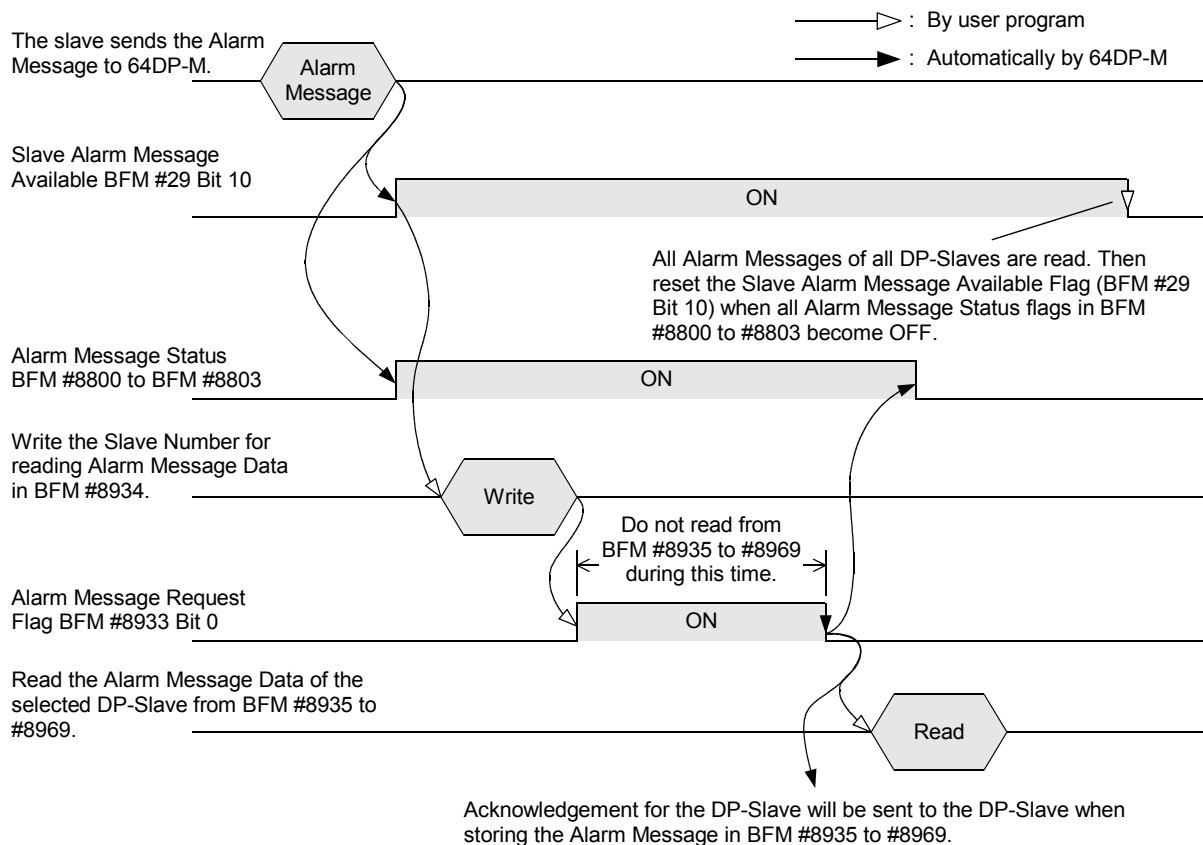

**2. Alarm Message reading procedure by not using Automatic Acknowledge Function**

- For Slave Alarm Message Available, refer to Subsection 6.13.9
- For Automatic Acknowledge Setting, Alarm Message Status, Alarm Message Counter, Alarm Message Request, Request Slave Number, Alarm Message Data, Alarm ACK request, Slave number, refer to Subsection 6.32.1, 6.32.3 to 6.32.9

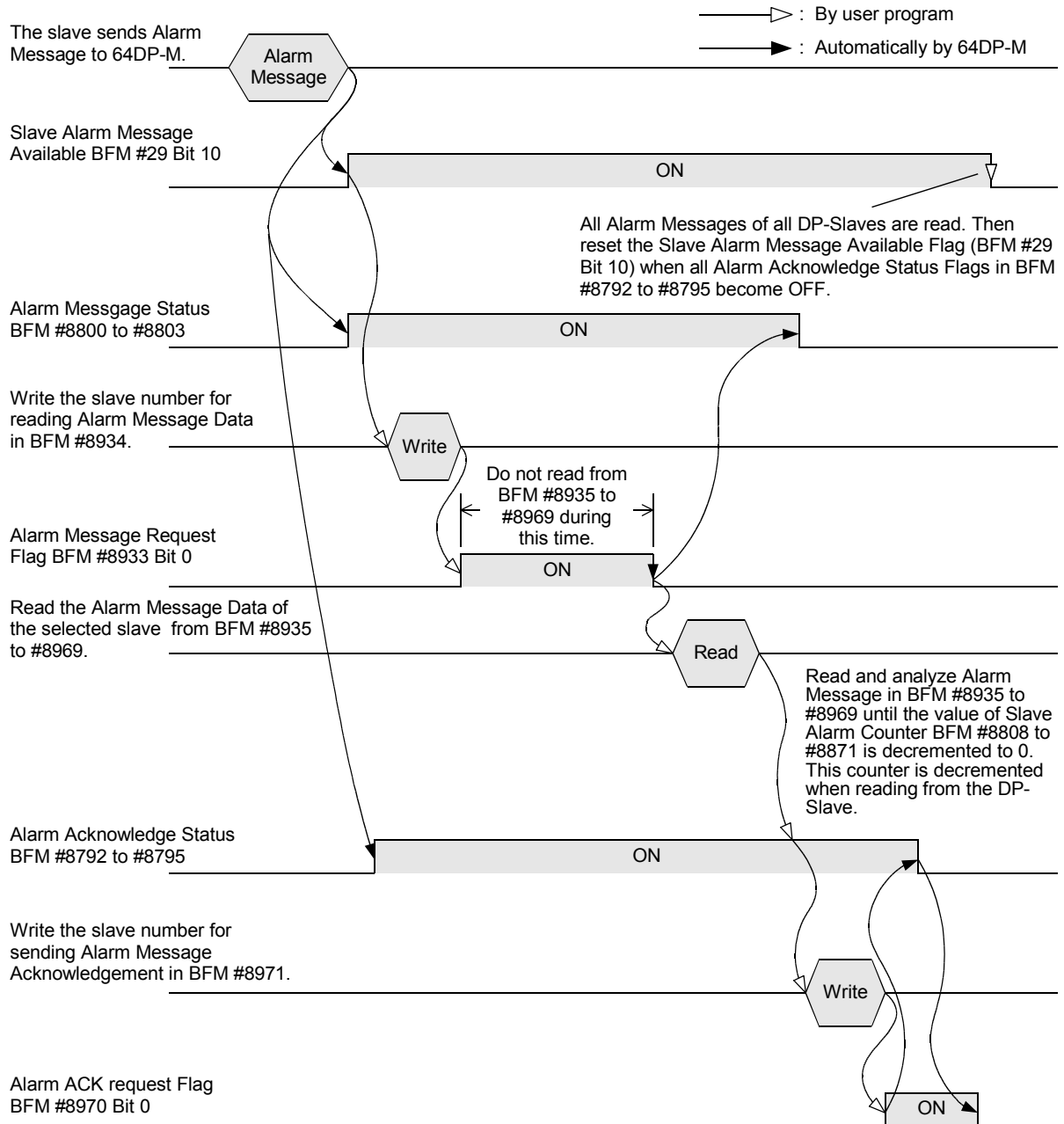

1	Introduction
2	Specifications
3	Installation
4	Wiring
5	Mode-Data Comms., Global Control
6	Allocation of Buffer Memories (BFMs)
7	Setting Parameters and Configuration
8	Example Program
9	Diagnostics

### 6.32.1 Automatic Acknowledge Setting [BFM #8784 to #8787]

**BFM Access: Read / Write**

Using the Automatic Acknowledge Function, the Automatic Acknowledge Flags should be set to ON (default value for each PROFIBUS DPV1 slave = ON). When the Bit is set to ON, alarms that are sent to the 64DP-M will be automatically acknowledged at the time they are read by the user program from BFM #8933 to #8969. Automatic Acknowledge Flags of each DP-Slave assignment is shown in the following table

BFM No.	Bit No.	Station No.	BFM No.	Bit No.	Station No.
BFM #8784	Bit 0	1	BFM #8786	Bit 0	33
	Bit 1	2		Bit 1	34
	Bit 2	3		Bit 2	35
	⋮	⋮		⋮	⋮
	Bit 15	16		Bit 15	48
BFM #8785	Bit 0	17	BFM #8787	Bit 0	49
	Bit 1	18		Bit 1	50
	Bit 2	19		Bit 2	51
	⋮	⋮		⋮	⋮
	Bit 15	32		Bit 15	64

### 6.32.2 Alarm Acknowledge Status [BFM #8792 to #8795]

**BFM Access: Read Only**

Shows the Alarm Acknowledge status when not using Automatic Acknowledge Function. The Alarm Acknowledgement Status Flag shows the DP-Slave which needs acknowledgement of Alarm Message. The flag is ON until the Alarm Acknowledge is sent after receiving Alarm Message from the DP-Slave.

When resetting the Slave Alarm Message Available Flag (BFM #29 Bit 10) or when reading the Alarm Message from BFM #8935 to #8969, this status flag will reset automatically.

BFM No.	Bit No.	Station No.	BFM No.	Bit No.	Station No.
BFM #8792	Bit 0	1	BFM #8794	Bit 0	33
	Bit 1	2		Bit 1	34
	Bit 2	3		Bit 2	35
	⋮	⋮		⋮	⋮
	Bit 15	16		Bit 15	48
BFM #8793	Bit 0	17	BFM #8795	Bit 0	49
	Bit 1	18		Bit 1	50
	Bit 2	19		Bit 2	51
	⋮	⋮		⋮	⋮
	Bit 15	32		Bit 15	64



### 6.32.3 Alarm Message Status [BFM #8800 to #8803]

**BFM Access: Read / Write**

Shows Alarm Message Status when not using Automatic Acknowledge Function. The Alarm Message Status Flag shows acknowledgement of an Alarm Message necessary DP-Slaves. The flag is ON until the alarm message is sent by Alarm ACK request [BFM #8970] after receiving Alarm Message from DP-Slave.

BFM No.	Bit No.	Station No.	BFM No.	Bit No.	Station No.
BFM #8800	Bit 0	1	BFM #8802	Bit 0	33
	Bit 1	2		Bit 1	34
	Bit 2	3		Bit 2	35
	⋮	⋮		⋮	⋮
	Bit 15	16		Bit 15	48
BFM #8801	Bit 0	17	BFM #8803	Bit 0	49
	Bit 1	18		Bit 1	50
	Bit 2	19		Bit 2	51
	⋮	⋮		⋮	⋮
	Bit 15	32		Bit 15	64

### 6.32.4 Alarm Message Counter [BFM #8808 to #8871]

**BFM Access: Read Only**

Alarm Message Counter shows the number of stocked Alarm Message for each DP-Slave when not using the Automatic Acknowledge Function.  
64DP-M can stock up to 2 Alarm Messages in Internal Alarm Message FIFO Area. Reading an Alarm Message decrements this value.

BFM No.	Station No.	BFM No.	Station No.
BFM #8808	1	BFM #8840	33
BFM #8809	2	BFM #8841	34
BFM #8810	3	BFM #8842	35
⋮	⋮	⋮	⋮
BFM #8823	16	BFM #8855	48
BFM #8824	17	BFM #8856	49
BFM #8825	18	BFM #8857	50
BFM #8826	19	BFM #8858	51
⋮	⋮	⋮	⋮
BFM #8838	31	BFM #8870	63
BFM #8839	32	BFM #8871	64

### 6.32.5 Alarm Message Request [BFM #8933]

**BFM Access: Read / Write (only 1 scan)**

Sets to ON when storing the Alarm Message of specified DP-Slave by BFM #8934 to BFM #8935 to #8969.

### 6.32.6 Request Slave Number [BFM #8934]

**BFM Access: Read / Write**

Write to slave number for storing the Alarm Message to BFM #8935 to #8969.  
The valid range lies between 1 and 64 slaves.

1	Introduction
2	Specifications
3	Installation
4	Wiring
5	Mode-Data Comms., Global Control
6	Allocation of Buffer Memories (BFMs)
7	Setting Parameters and Configuration
8	Example Program
9	Diagnostics

### 6.32.7 Alarm Message [BFM #8935 to #8969]

**BFM Access: Read Only**

Reads the Alarm Message from this area.  
Data format of Alarm Message shows the following

BFM #8935	SlaveAddress
BFM #8936	Type
BFM #8937	SlotNumber
BFM #8938	Specifier
BFM #8939	BlockLength
BFM #8940 to #8969	DiagnosticUserData [59 bytes]

#### 1. SlaveAddress

PROFIBUS address of the DP-Slave whose alarm entry has been read. The valid range lies between 1 and 125.

#### 2. Type

Value	Description
0x01	Diagnostic alarm (e.g. short circuit or excess temperature),
0x02	Process alarm (event in the connected process)
0x03	Pull alarm (module removed)
0x04	Plug alarm (module added)
0x05	Status alarm (change of state)
0x06	Update alarm (change of parameters)
0x20	User-specific alarms. The maximum possible number of user specific alarms is 0x5E

#### 3. SlotNumber

Number of the slot which has caused the alarm. This number is defined by the addressing for acyclic services.

#### 4. Specifier

Characterizes the state of the alarm and contains the sequence number of the alarm. The range for the sequence number lies between 0 and 31.

##### States:

- 0 = no further differentiation.
- 1 = Alarm appears
- 2 = Alarm disappears
- 3 = Alarm disappears and pending
- 4 = Alarm requires additional user acknowledge

##### Note

In addition to the Alarm Acknowledge, the alarm needs a special acyclic write service for resetting.

#### 5. BlockLength

Length of the alarm data. The valid range lies between 4 and 63.

#### 6. DiagnosticUserData [ ]

In this data, the DP-Slave can store additional vendor specific alarm data.

→ **For additional vendor specific alarm data, please see manual of the DP-Slave module**

### 6.32.8 Alarm ACK Request [BFM #8970]

**BFM Access: Read / Write (only 1 scan)**

Sets to ON when sending the Acknowledge for Alarm Message to specified DP-Slave by BFM #8971. When sending acknowledge to the DP-Slave, this request and Alarm Message Status BFM #8800 to #8803 will be reset.

### 6.32.9 Slave Number [BFM #8971]

**BFM Access: Read / Write**

Write the slave number which shall be sent Acknowledge for Alarm Message.

## 6.33 Address Information Area [BFM #9140 to #9267]

**BFM Access: Read Only**

Address Information Area shows the following information of each projected DP-Slave in 64DP-M. Address Information Area assignment is as follows.

- Slave FDL address
- Input data length (bytes)
- Output data length (bytes)

#### Note

- The slave FDL address is different from the projected slave number. Slave FDL addresses do not need to be sequential numbers, but are displayed in ascending order.
- Any station address that is not assigned is set to "FFFF" hex code, the input or output byte length is "FF" hex code.

#### Address Information Area assignment:

BFM Address	Bit 15	Upper byte	Lower byte	Bit 0
BFM #9140	Slave FDL address of 1st station			
#9141	1st station output byte length		1st station input byte length	
#9142	Slave FDL address of 2nd station			
#9143	2nd station output byte length		2nd station input byte length	
⋮	⋮			
#9266	Slave FDL address of 64th station			
#9267	64th station output byte length		64th station input byte length	

1

Introduction

2

Specifications

3

Installation

4

Wiring

5

Mode-Data Comms., Global Control

6

Allocation of Buffer Memories (BFMs)

7

Setting Parameters and Configuration

8

Example Program

9

Diagnostics

**Example;**

In following configuration and I/O data assignment case, Address Information Area is shown the below:

1) System configuration of example

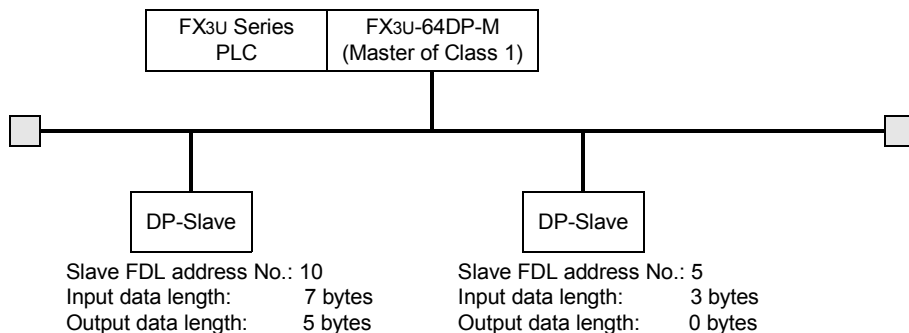

2) Input Data Area and Output Data Area of example

BFM Address		BFM Address	Upper byte	Lower byte	Bit 0
BFM #350	1st station	BFM #350	2nd byte	1st byte	
#351		#351	Not used	3rd byte	
#352	2nd station	#352	2nd byte	1st byte	
#355		#353	4th byte	3rd byte	
#356	This area is not used in this system configuration	#354	6th byte	5th byte	
		#355	Not used	7th byte	
		#356	Not used	Not used	
#2349	1st station	#357	Not used	Not used	
This DP-Slave does not have output data assigned.		#2349	Not used	Not used	
#2350	2nd station	#2349	Not used	Not used	
		#2350	2nd byte	1st byte	
#2352	This area is not used in this system configuration	#2351	4th byte	3rd byte	
#2353		#2352	Not used	5th byte	
		#2353	Not used	Not used	
		#2354	Not used	Not used	
#3373		#3373	Not used	Not used	

3) Example of Address Information Area

BFM Address	Bit 15	Upper byte	Lower byte	Bit 0
BFM #9140	Slave FDL address of 1st station = 5 H			
#9141	1st station output byte length = 0		1st station input byte length = 3	
#9142	Slave FDL address of 2nd station = 10 H			
#9143	2nd station output byte length = 5 H		2nd station input byte length = 7 H	
#9144	Slave FDL address of 3rd station = FFFF H			
#9145	3rd station output byte length = FF H		3rd station input byte length = FF H	
...	...			
#9266	Slave FDL address of 64th station = FFFF H			
#9267	64th station output byte length = FF H		64th station input byte length = FF H	

### 6.34 Global Control

The 64DP-M supports SYNC/UNSYNC and FREEZE/UNFREEZE Global Control Service. The 64DP-M is normally set as UNSYNC and UNFREEZE in Global Control Mode.

→ For allocation of setting error flags, refer to Section 6.12

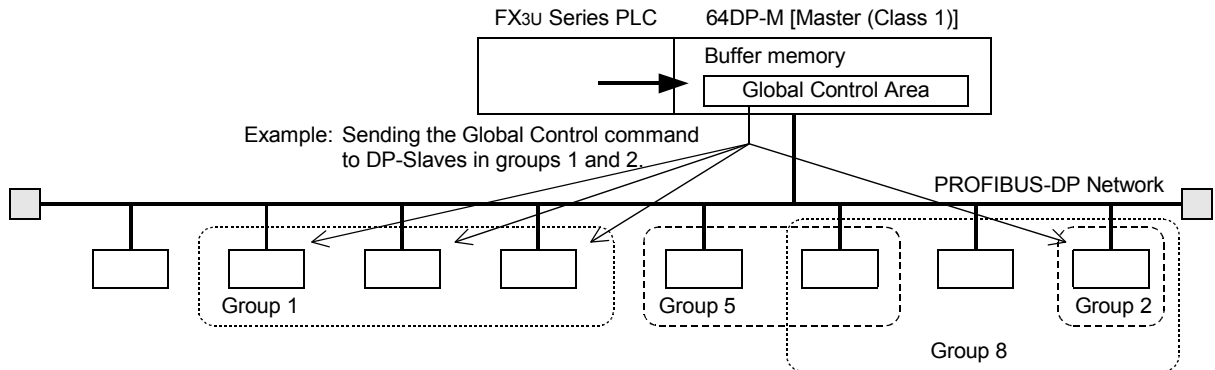

#### 6.34.1 Global Control Area [BFM #9390]

**BFM Access: Read / Write**

Global Control contains 4 functions, SYNC, UNSYNC, FREEZE, and UNFREEZE. These are functions that are broadcasted to several DP-Slaves at the same time, in order to synchronize the update of DP-Slave outputs or the latching of DP-Slave inputs.

Each DP-Slave which is projected to execute a Global Control Function belongs to one or more groups among 8 groups. The group number assignment for each DP-Slave is set by GX Configurator-DP. In the 64DP-M the group can be arbitrarily specified and the transmission of a Global Control Command can be triggered. As a result, the 64DP-M broadcasts a group specific Global Control Command, which will enable the related DP-Slaves to perform the required action.

The Global Control Function is executed using the Global Control Area (BFM #9390).

##### 1. Global Control Area

Bit No.	Description	ON (1)	OFF (0)
Bit 0, 1	Not used		
Bit 2 to 5	Global control commands	See "2. Selecting a Global Control command".	
Bit 6, 7	Not used		
Bit 8 *1	Group 1	This group executes the global control command which is specified by Bit 2 to 5.	This group does not execute the global control command which is specified by Bit 2 to 5. All bits OFF will automatically select all groups.
Bit 9 *1	Group 2		
Bit 10 *1	Group 3		
Bit 11 *1	Group 4		
Bit 12 *1	Group 5		
Bit 13 *1	Group 6		
Bit 14 *1	Group 7		
bit 15 *1	Group 8		

\*1. Selection of multiple groups is possible

##### Note

In case a Global Control Command is sent with no group set, the Global Control Command is sent to all Groups (1 to 8).

- 1 Introduction
- 2 Specifications
- 3 Installation
- 4 Wiring
- 5 Mode-Data Comms., Global Control
- 6 Allocation of Buffer Memories (BFMs)
- 7 Setting Parameters and Configuration
- 8 Example Program
- 9 Diagnostics

## 2. Selecting a Global Control command

Bit No.				Global Control Commands			
Bit 5	Bit 4	Bit 3	Bit 2	UNFREEZE	FREEZE	UNSYNC	SYNC
0	0	0	0	*1	*1	*1	*1
0	0	0	1	✓*2			
0	0	1	0		✓*2		
0	1	0	0			✓*2	
1	0	0	0				✓*2
0	1	0	1	✓*2		✓*2	
0	1	1	0		✓*2	✓*2	
1	0	0	1	✓*2			✓*2
1	0	1	0		✓*2		✓*2

\*1. When setting 0 to Bit 2 to 5, a setting error will occur in BFM #29 Bit 4 and BFM #28 Bit 13.

\*2. Executable commands, writing any other wrong value to these bits will have no effect on Global Control Execution, however an error bit will be displayed in BFM #29 bit 4 and BFM #28 bit 13.

### 6.34.2 SYNC and UNSYNC Global Control

The SYNC/UNSYNC Global Control controls the output data communication from the 64DP-M to the DP-Slave.

→ For SYNC and UNSYNC Global Control command sending procedure, refer to the next page

→ For allocation of Global Control Area, refer to Section 6.34.1

→ For Cyclic Output Data, refer to Section 6.25

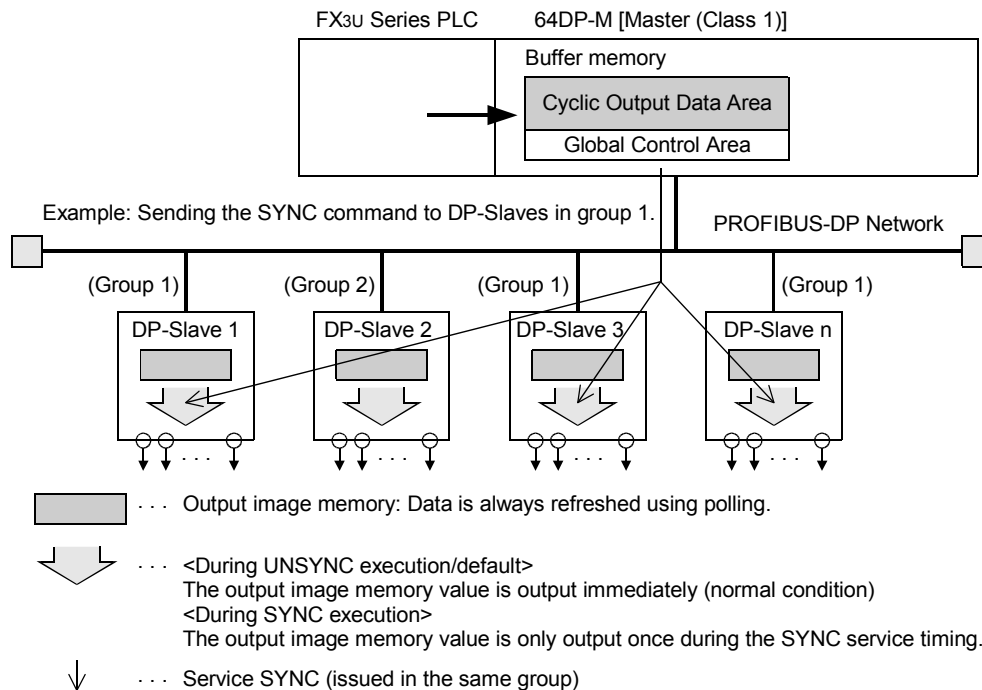

#### 1) SYNC Global Control command

In SYNC mode, the output data sent to DP-Slaves belonging to the group specified by BFM #9390 is not immediately written to the actual physical outputs of the DP-Slave. The output data are stored inside the DP-Slaves until the following SYNC/UNSYNC Global Control command is sent, then the output data of those DP-Slaves are updated. The first SYNC command sent to the DP-Slaves will switch them into SYNC mode.

#### 2) UNSYNC Global Control command

When sending an UNSYNC Global Control command to a DP-Slave which is in SYNC mode, the DP-Slave will be released from SYNC mode and will cause that output data sent to this DP-Slave are continuously updated. By specifying a group of DP-Slaves in BFM #9390 the UNSYNC command can be performed on arbitrary DP-Slaves, similar to the SYNC command.

**Note**

When using the SYNC Global Control command, output data (sent to the DP-Slave) is not refreshed until the next SYNC or UNSYNC global command is sent to the DP-Slave. That is, even if new data is written to the Output Data Area (BFM #2350 to #3373) by TO instructions, etc., it is not refreshed until the following SYNC or UNSYNC global command is issued from the PROFIBUS-DP in SYNC Global Control Mode.

**SYNC and UNCYNC Global Control command sending procedure**

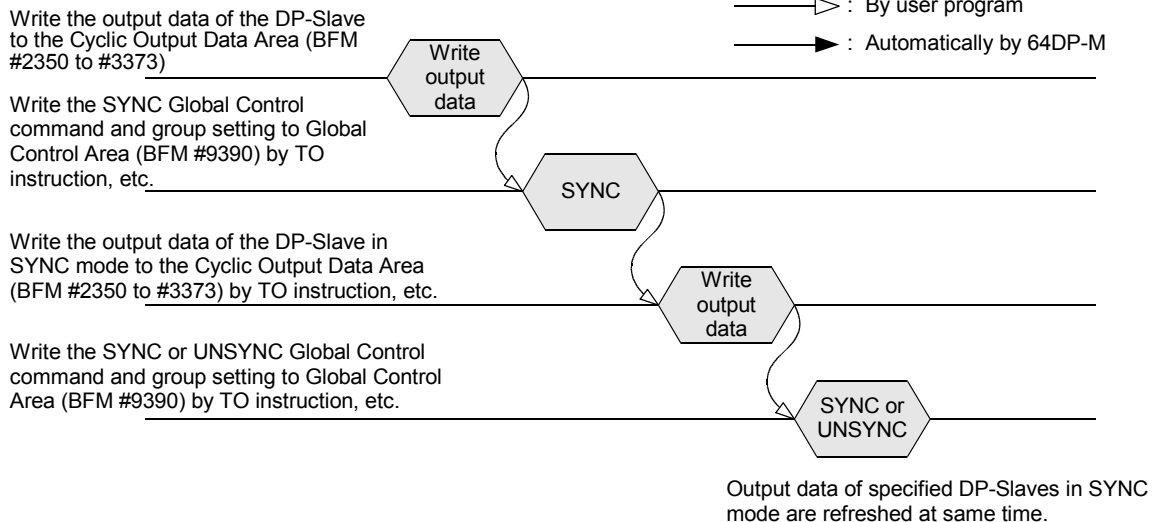

**6.34.3 FREEZE and UNFREEZE Global Control**

The FREEZE/UNFREEZE Global Control controls the input data communication from the DP-Slave to the 64DP-M.  
 → For FREEZE and UNFREEZE Global Control command sending procedure, refer to the next page  
 → For allocation of Global Control Area, refer to Section 6.34.1  
 → For Cyclic Input Data, refer to Section 5.1 and 6.23

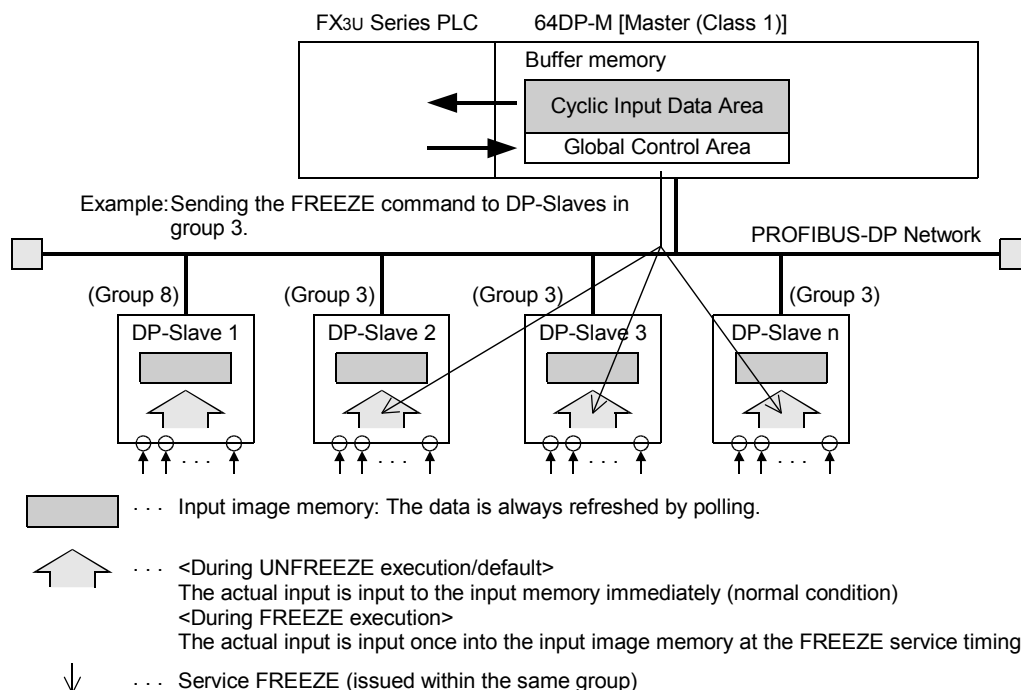

1) FREEZE Global Control command

In Freeze mode, the input data of DP-Slaves which belong to the group specified by BFM #9390 is set to freeze (no cyclical refresh of input data).

Only after sending another FREEZE/UNFREEZE Global Control command to the DP-Slaves is the input data read from those DP-Slaves into the 64DP-M updated.

1 Introduction  
 2 Specifications  
 3 Installation  
 4 Wiring  
 5 Mode-Data Comms., Global Control  
 6 Allocation of Buffer Memories (BFMs)  
 7 Setting Parameters and Configuration  
 8 Example Program  
 9 Diagnostics

2) UNFREEZE Global Control command

When sending an UNFREEZE Global Control command to a DP-Slave which is in FREEZE mode, the DP-Slave will be released from FREEZE mode and will cause that input data sent from this DP-Slave to be continuously updated.

By specifying a group of DP-Slaves in BFM #9390 the UNFREEZE command can be performed on arbitrary DP-Slaves, similar to the FREEZE command.

**Note**

When using FREEZE Global Control command, input data (received from DP-Slave) is not refreshed until next FREEZE or UNFREEZE global command is send to the DP-Slave.

That is, even if the input (receive) data from the DP-Slave reads the Input Data Area (BFM #350 to #1373) by FROM instructions, etc., this is not refreshed until the following FREEZE or UNFREEZE global command is issued from the PROFIBUS-DP in FREEZE Global Control Mode.

**FREEZE and UNFREEZE Global Control command sending procedure**

Write the FREEZE Global Control command and group setting to Global Control Area (BFM #9390) by TO instruction, etc.

Read the input data of the DP-Slave from the Cyclic Input Data Area (BFM #350 to #1373).

Write the FREEZE or UNFREEZE Global Control command and group setting to Global Control Area (BFM #9390) by TO instruction, etc.

Set Input Data Send Flag (BFM #100 to #163) to ON for the DP-Slave which changed to UNFREEZE mode (only needs if Input Data Consistency Activate/Deactivate Flags of DP-Slave is ON).

Read the input data of the DP-Slave in FREEZE mode from the Cyclic Input Data Area (BFM #350 to #1373) by FROM instruction, etc.

—▷ : By user program  
—▶ : Automatically by 64DP-M

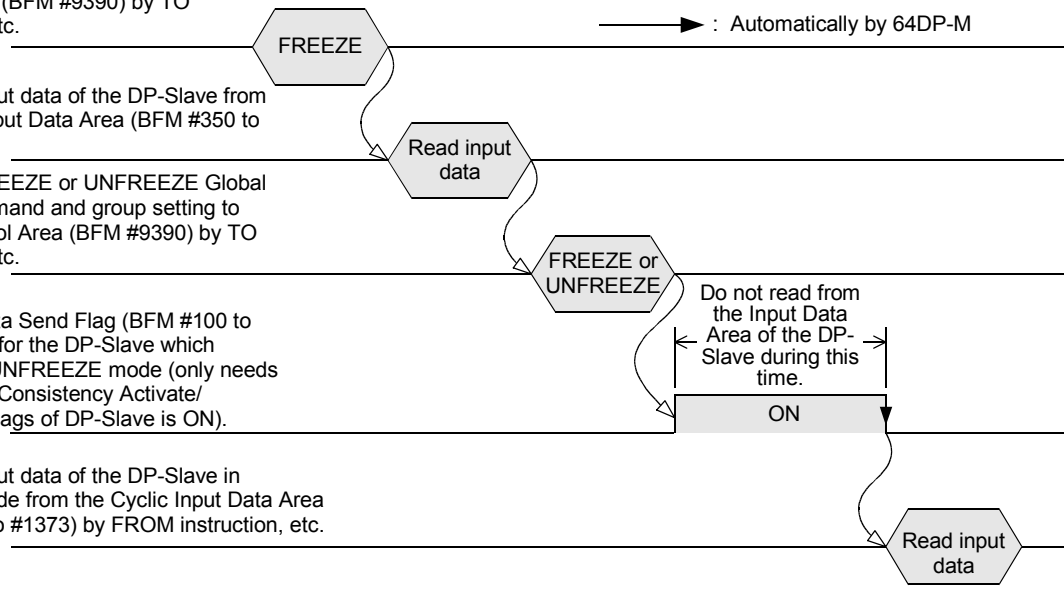

64DP-M will receive by input data specified DP-Slaves in FREEZE mode via cyclic communication by polling.

**6.35 Information Dwell Time Setting [BFM #9394]**

**BFM Access: Read / Write**

The Information Dwell Time is used to specify a time period after the start of data exchange where any Diagnosis Information from DP-Slaves is not displayed in the 64DP-M. The time value in the buffer memory can be adjusted in one second steps. Default value is K4 (in 1 second steps). The setting range is between 1 to 30.

After the 64DP-M has been switched into data exchange (RUN) mode and the set time interval is expired, the 64DP-M will clear the internal diagnosis FIFO.

**Note**

If the error action flag "Goto Clear State" is set in the Master Parameter Settings of GX Configurator-DP, the 64DP-M will probably only enter the data exchange mode (RUN) after the Information Dwell Time. This is due to the fact that during network startup all DP-Slaves will send startup Slave Diagnostic Informations to the 64DP-M. After these have been cleared, the 64DP-M will enter the data exchange state (RUN). During this time the RUN LED of the 64DP-M will be turned on/off in 500ms intervals.



## 6.36 Cyclic Slave Status Area [BFM #9399 to #9402]

**BFM Access: Read Only**

Cyclic Slave Status Area shows the cyclic communication status of each projected DP-Slave. A Bit set to ON means that the communication is OK for this DP-Slave.

The flag assignments are shown in the following table.

BFM No.	Bit No.	Station No.	BFM No.	Bit No.	Station No.
BFM #9399	Bit 0	1	BFM #9401	Bit 0	33
	Bit 1	2		Bit 1	34
	Bit 2	3		Bit 2	35
	⋮	⋮		⋮	⋮
	Bit 15	16		Bit 15	48
BFM #9400	Bit 0	17	BFM #9402	Bit 0	49
	Bit 1	18		Bit 1	50
	Bit 2	19		Bit 2	51
	⋮	⋮		⋮	⋮
	Bit 15	32		Bit 15	64

## 6.37 Acyclic Slave Status Area [BFM #9407 to #9410]

**BFM Access: Read Only**

The Acyclic Slave Status Area is used to check the acyclic communication status for each DP-Slave. A Bit set to ON signals that the communication is OK for this DP-Slave.

The status flag assignment is shown the following table.

BFM No.	Bit No.	Station No.	BFM No.	Bit No.	Station No.
BFM #9407	Bit 0	1	BFM #9409	Bit 0	33
	Bit 1	2		Bit 1	34
	Bit 2	3		Bit 2	35
	⋮	⋮		⋮	⋮
	Bit 15	16		Bit 15	48
BFM #9408	Bit 0	17	BFM #9410	Bit 0	49
	Bit 1	18		Bit 1	50
	Bit 2	19		Bit 2	51
	⋮	⋮		⋮	⋮
	Bit 15	32		Bit 15	64

1

Introduction

2

Specifications

3

Installation

4

Wiring

5

Mode-Data Comms., Global Control

6

Allocation of Buffer Memories (BFMs)

7

Setting Parameters and Configuration

8

Example Program

9

Diagnostics

## 6.38 Cyclic Input Data Start Address Area [BFM #9426 to #9489]

**BFM Access: Read Only**

Cyclic Input Start Address Area shows the start address of Input Data Area of each DP-Slave. Data is set in this area during module startup according to the parameter data stored in the 64DP-M. The start address is set in 1 word units for both input and output. If no input data is assigned to a DP-Slave, then the start BFM address of this DP-Slave will be set to FFFF hex. After boot-up of the 64DP-M, this information is available, after the "Module READY Signal" BFM #5 Bit 0 is set to ON by the 64DP-M.

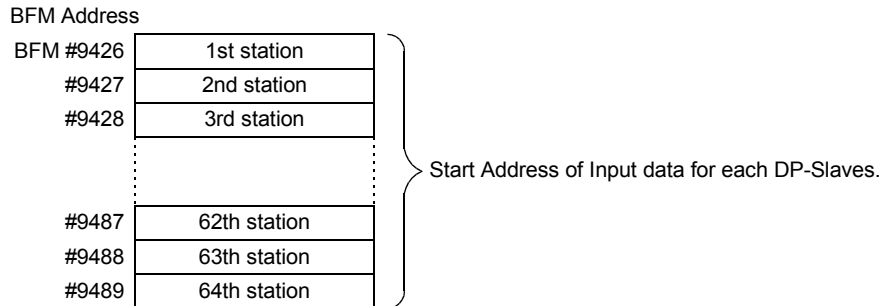

**Example:**

For the following I/O configuration case, the Cyclic Input Data Start Address Area is as shown below.

1) Input configuration for example

a) Station No. and input data length

Station No.	Input Data Length
Station No.1 (Address No.0)	3 bytes
Station No.2 (Address No.2)	6 bytes

b) Input data area assignment for Example (BFM #350 to #1373)

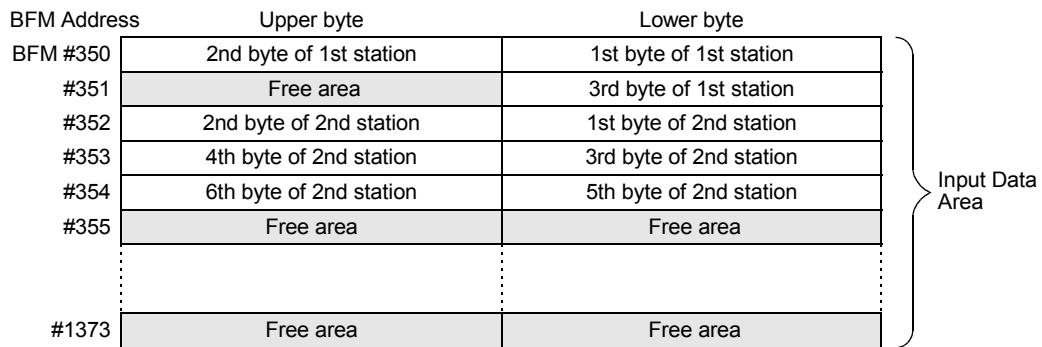

2) Input Start Address Area for Example (BFM #9426 to #9489)

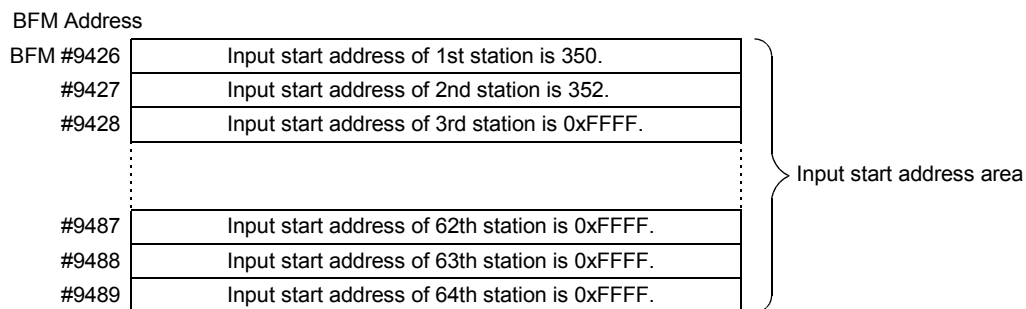

## 6.39 Cyclic Output Data Start Address Area [BFM #9551 to #9614]

**BFM Access: Read Only**

Cyclic Output Start Address Area shows the start address of Output Data Area of each DP-Slave. Data is set in this area during module startup according to the parameter data stored in the 64DP-M. The start BFM address is set in 1 word units for both input and output. If no output data is assigned to a DP-Slave, then the start address of this DP-Slave will be set to FFFF hex. After boot-up of the 64DP-M, this information is available, after the "Module READY Signal" BFM #5 Bit 0 is set to ON by the 64DP-M.

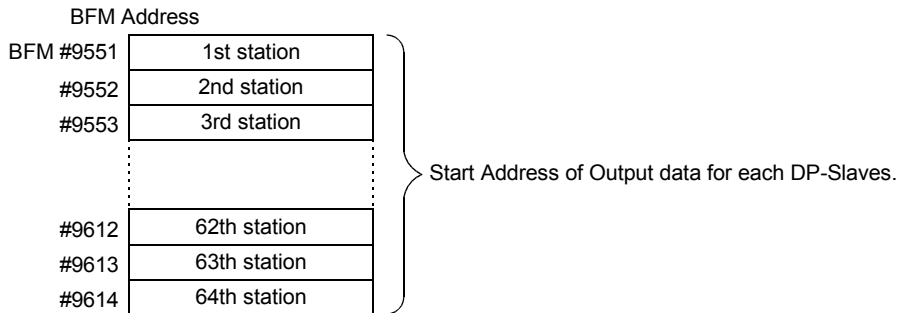

### Example:

For the following I/O configuration case, the Cyclic Output Data Start Address Area is as shown below.

#### 1) Output configuration

##### a) Station No. and output data length

Station No.	Output Data Length
Station No.1 (Address No.0)	5 bytes
Station No.2 (Address No.2)	2 bytes

##### b) Output data area assignment for Example (BFM #2350 to #3373)

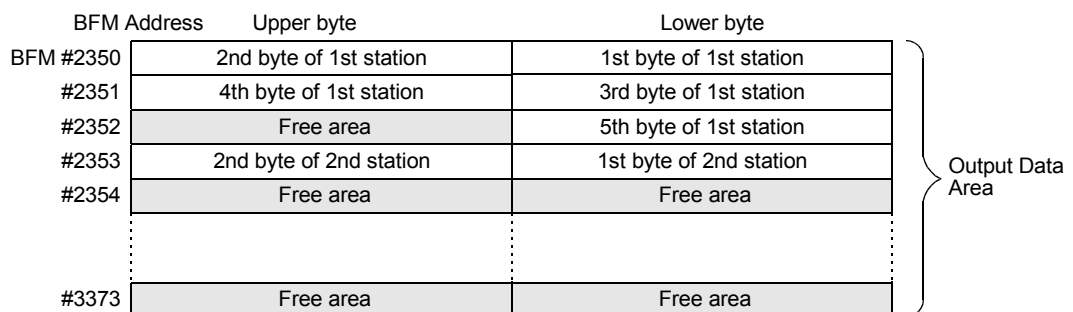

#### 2) Output Start Address Area for Example (BFM #9551 to #9614)

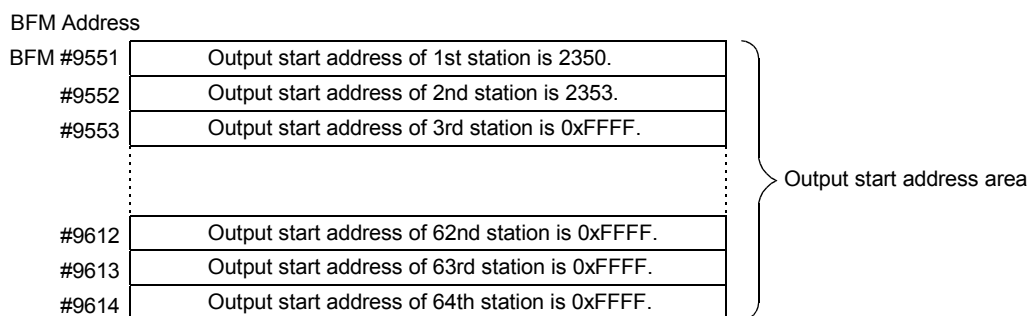

## 6.40 Number of Configured Slaves [BFM #9676]

**BFM Access: Read Only**

Shows the total number of projected DP-Slaves in 64DP-M.

## 6.41 Slave Number, Slave FDL Address, Slave PNO ID [BFM #9677 to #9868]

**BFM Access: Read Only**

Shows the following information of each projected DP-Slave. These values are set by GX Configurator-DP. The DP-Slaves are displayed in ascending Slave FDL Address order, i.e. the DP-Slave with the lowest PROFIBUS address becomes slave number one, the DP-Slave with the next lowest PROFIBUS address becomes slave number two, etc.

After boot-up of the 64DP-M, this information is available after the Module READY Signal BFM #5 Bit 0 is set to ON by the 64DP-M.

→ For Module READY Signal [BFM #5 Bit 0], refer to Section 6.7

- Projected slave number
- PROFIBUS Slave FDL address
- PNO-ID

BFM No.	Station No.	BFM-address	BFM No.	Station No.	BFM-address
BFM #9677	1	1 (Slave Number)	BFM #9686	4	4 (Slave Number)
BFM #9678		Slave FDL address	BFM #9687		Slave FDL address
BFM #9679		PNO-ID	BFM #9688		PNO-ID
BFM #9680	2	2 (Slave Number)	⋮	⋮	⋮
BFM #9681		Slave FDL address			
BFM #9682		PNO-ID			
BFM #9683	3	3 (Slave Number)	BFM #9866	64	64 (Slave Number)
BFM #9684		Slave FDL address	BFM #9867		Slave FDL address
BFM #9685		PNO-ID	BFM #9868		PNO-ID

## 6.42 PROFIBUS Scan Function

Lists the following detected DP-Slave information on PROFIBUS-DP network when using this function. These information acquired by this function is stored in the buffer memory, described by the table below.

- Configuration difference list
- Total number of detected DP-Slaves
- Slave number, Slave FDL address and PNO-ID of each detected DP-Slave

BFM No.	Description	Reference
BFM #10052	Get DP-Slave List Request; Set to ON when using the PROFIBUS Scan Function in mode except Cyclic Exchange Mode.	Subsection 6.42.1
BFM #10053 to #10060	Configuration Difference Status; Shows difference between the projected configuration and the detected configuration.	Subsection 6.42.2
BFM #10061	Scan Slave FDL Address; Shows the present scanned address during scan process. (0 to 126)	Subsection 6.42.3
BFM #10062	Number of Detected DP-Slaves; Shows total number of detected DP-Slaves.	Subsection 6.42.4
BFM #10063 to #10443	Detected DP-Slave Lists; Shows the Slave Number, Slave FDL address and PNO-ID of each detected DP-Slave.	Subsection 6.42.5

### 6.42.1 Get DP-Slave List Request [BFM #10052]

**BFM Access: Read / Write (only 1 scan)**

Set to ON to start the PROFIBUS Scan Function which scans the PROFIBUS-DP network for actually connected DP-slaves.

After scanning, this bit will automatically be reset. This scan function will only operate if the 64DP-M is not in Cyclic Data Exchange Mode (STOP mode only).

The following information of detected DP-Slaves.

- Configuration difference list
- Total number of detected DP-Slaves
- Slave number, Slave FDL address and PNO-ID of each detected DP-Slave

### 6.42.2 Configuration Difference Status [BFM #10053 to #10060]

**BFM Access: Read Only**

The status flag of the corresponding DP-Slave is ON if there are discrepancies between the projected configuration and the detected configuration. The Configuration Difference Status flag assignment shows in the following table.

BFM No.	Bit No.	Station No.	BFM No.	Bit No.	Station No.
BFM #10053	Bit 0	1	BFM #10057	Bit 0	65
	Bit 1	2		Bit 1	66
	⋮	⋮		⋮	⋮
	Bit 15	16		Bit 15	70
BFM #10054	Bit 0	17	BFM #10058	Bit 0	71
	Bit 1	18		Bit 1	72
	⋮	⋮		⋮	⋮
	Bit 15	32		Bit 15	86
BFM #10055	Bit 0	33	BFM #10059	Bit 0	87
	Bit 1	34		Bit 1	88
	⋮	⋮		⋮	⋮
	Bit 15	48		Bit 15	102
BFM #10056	Bit 0	49	BFM #10060	Bit 0	103
	Bit 1	50		Bit 1	104
	⋮	⋮		⋮	⋮
	Bit 14	63		Bit 14	127
	Bit 15	64		Bit 15	-

**Note;**

If there is a DP-Slave missing in the detected (scanned) configuration, all other Bits with a higher address than this DP-Slave will be set to ON, as the PNO-ID code of the projected slave number is different from the detected (scanned) configuration for these DP-Slaves. In this case, for troubleshooting it is advisable to start with the lowest slave number that is displayed in the Table of Configuration Differences.

1 Introduction  
2 Specifications  
3 Installation  
4 Wiring  
5 Mode-Data Comms., Global Control  
6 Allocation of Buffer Memories (BFMs)  
7 Setting Parameters and Configuration  
8 Example Program  
9 Diagnostics

### 6.42.3 Scan Slave FDL Address [BFM #10061]

**BFM Access: Read Only**

Shows the present scanned address while scan is in process. When the scan is finished, this value is set to 0.

### 6.42.4 Number of Detected Slave [BFM #10062]

**BFM Access: Read Only**

Shows total number of detected DP-Slaves.

### 6.42.5 Detected Slave Lists [BFM #10063 to #10443]

**BFM Access: Read Only**

Shows the slave number, slave FDL address and PNO-ID of each detected DP-Slave.  
Detected DP-Slave lists shows the following table.

BFM No.	Station No.	BFM-address
BFM #10063	1	1 (Slave Number)
BFM #10064		Slave FDL address
BFM #10065		PNO-ID
BFM #10066	2	2 (Slave Number)
BFM #10067		Slave FDL address
BFM #10068		PNO-ID
BFM #10069	3	3 (Slave Number)
BFM #10070		Slave FDL address
BFM #10071		PNO-ID

BFM No.	Station No.	BFM-address
BFM #10072	4	4 (Slave Number)
BFM #10073		Slave FDL address
BFM #10074		PNO-ID
⋮	⋮	⋮
BFM #10441	127	127 (Slave Number)
BFM #10442		Slave FDL address
BFM #10443		PNO-ID

## 7. Setting Parameters and Configuration [GX Configurator-DP]

### STARTUP AND MAINTENANCE PRECAUTIONS



- Do not touch any terminal while the PLC's power is on.  
Doing so may cause electric shock or malfunctions.
- Before cleaning or retightening terminals, externally cut off all phases of the power supply.  
Failure to do so may cause electric shock.
- Before modifying or disrupting the program in operation or running the PLC, carefully read through this manual and the associated manuals and ensure the safety of the operation.  
An operation error may damage the machinery or cause accidents.

### STARTUP AND MAINTENANCE PRECAUTIONS



- Do not disassemble or modify the unit.  
Doing so may cause fire, equipment failures, or malfunctions.  
\* For repair, contact your local Mitsubishi Electric distributor.
- Do not drop the product and exert strong impact. Doing so may cause damage.
- Turn off the power to the PLC before attaching or detaching the peripheral devices.  
Failure to do so may cause equipment failures or malfunctions.

Use GX Configurator-DP (Ver.7.00A or later) for the setting of the parameters and configuration for PROFIBUS-DP network including 64 DP-M.

→ For operation details on GX Configurator-DP, refer to the GX Configurator-DP Software Manual.

→ For example setting of parameter and configuration, refer to Section 8.1.3

#### Point

- 1) Module type  
Select the "PROFIBUS DP V1 (FX3U-64DP-M)" on "Network Setup" dialog box.
- 2) Operation mode  
Set Operation Mode in BFM #39 by user program.

→ For Operation Mode, refer to Section 6.20

1

Introduction

2

Specifications

3

Installation

4

Wiring

5

Mode-Data Comms., Global Control

6

Allocation of Buffer Memories (BFMs)

7

Setting Parameters and Configuration

8

Example Program

9

Diagnostics

## 7.1 Master Parameter

Set the master parameter about the following parameters on "Master Setting" dialog box.

→ For details on "Master Setting" dialog box, refer to **GX Configurator-DP Software Manual**

Parameter	Description	Setting Range or Select Item
Name	Name of the DP-Master. Default: PROFIBUS Master	-
Baud Rate (Transmission speed) [bps]	Transfer rate for the communication. Define a baud rate that is supported by all DP-Slaves. Default: 1.5 Mbps	9.6k, 19.2k, 93.75k, 187.5k, 500k, 1.5 M, 3M, 6M, 12M
FDL address	FDL address (Slave FDL address) Default: 0	0 to 125
Head address on PLC	Set unit number of 64DP-M. Default: 0	0x0 to 0x7
Error action flag	Output processing after failure. Activate if you want to have the outputs shut off in case of error occurrence (recommended for drives, inverters etc.). Default: Not checked	-
Min. slave interval [× 100 μs]	Smallest allowed period of time between two DP-Slave poll cycles. This ensures that the sequence of function requests from the 64DP-M can be handled by the DP-Slave. This value is valid for all installed DP-Slaves. The real PROFIBUS (bus) cycle time (minimum slave interval) can not become smaller than 3 ms. Default: 30 (30 × 100 μs [3 ms])	1 to 65535
Polling timeout [× 1 ms]	In case of master-master communication this parameter specifies the max. amount of time it may take the requestor to fetch the response. Default: 50 (50 ms)	1 to 65535
Data control time [× 10 ms]	This parameter defines the period of time during which the DP-Master module notifies the DP-Slave operation status. This time is 6 times longer than the watchdog control of DP-Slaves. Default: 100 (100 × 10 ms [1 second])	1 to 65535
Watchdog	This check box enables the watchdog checking in all DP-Slaves. Default: Not checked	-
Slave Watchdog time [× 10 ms]	When the check box Watchdog is checked, this specifies the maximum time without communication, after which the DP-Slave will regard the connection to the DP-Master to be broken. If the DP-Slave supports PROFIBUS-DPV1, the unit will automatically be set to either "10 ms" or "1 ms", depending on the setting of the "Watchdog Timebase" flag in the user parameters of the DP-Slave. <b>NOTE:</b> The unit is only changed, if the WDT option is enabled specifically for a DP-Slave. If WDT has been enabled via the DP-Master, all DP-Slaves must use the default timebase of 10ms.	1 to 65025



## 7.2 Bus Parameter

Set the bus parameter about the following parameters on "Bus Parameter" dialog box.

→ For details on "Bus Parameter" dialog box, refer to **GX Configurator-DP Software Manual**

Parameter	Description	Setting Range
Baud Rate (Transmission speed) [bps]	Transfer rate: Must be supported by all DP-Slaves. Transfer rate can be selected when opening Bus parameter dialog box from Master setting dialog box. Default: 1.5Mbps	9.6k, 19.2k, 93.75k, 187.5k, 500k, 1.5 M, 3M, 6M, 12M
Slot time (T_sl) [TBIT]	Slot time: Max. Interval to wait for response Default: 300 (300 TBIT)	37 to 16383
min T_sdr [TBIT]	Min. Station delay of responder Default: 11 (11 TBIT)	11 to 1023
max T_sdr [TBIT]	Max. Station delay of responder Default: 150 (150 TBIT)	137 to 1023
Quiet time (T_qui) [TBIT]	Quiet time; T = 0, if no repeater present Default: 0 (0 TBIT)	0 to 127
Setup time (T_set) [TBIT]	Setup time Default: 1 (1 TBIT)	1 to 255
Target Rot. (T_tr) [TBIT]	Target token rotation time Default: 50000 (5000 TBIT)	256 to 16777215
GAP factor	Controls the GAP update time (T_gud) Default: 10	1 to 100
HSA	Highest station address Default: 126	2 to 126
Max. retry limit	Maximum retry limit Default: 1	1 to 7

## 7.3 Network Configuration

Set the system configuration of PROFIBUS-DP network on "graphical network editor" window.

→ For operation details, refer to **GX Configurator-DP Software Manual**

1

Introduction

2

Specifications

3

Installation

4

Wiring

5

Mode-  
Data Comms.,  
Global Control

6

Allocation of  
Buffer Memories  
(BF-Ms)

7

Setting  
Parameters and  
Configuration

8

Example  
Program

9

Diagnostics

## 8. Example Program

### STARTUP AND MAINTENANCE PRECAUTIONS



- Do not touch any terminal while the PLC's power is on. Doing so may cause electric shock or malfunctions.
- Before cleaning or retightening terminals, externally cut off all phases of the power supply. Failure to do so may cause electric shock.
- Before modifying or disrupting the program in operation or running the PLC, carefully read through this manual and the associated manuals and ensure the safety of the operation. An operation error may damage the machinery or cause accidents.

### STARTUP AND MAINTENANCE PRECAUTIONS



- Do not disassemble or modify the unit. Doing so may cause fire, equipment failures, or malfunctions. \* For repair, contact your local Mitsubishi Electric distributor.
- Do not drop the product and exert strong impact. Doing so may cause damage.
- Turn off the power to the PLC before attaching or detaching the peripheral devices. Failure to do so may cause equipment failures or malfunctions.

## 8.1 Example Program 1

### 8.1.1 System Configuration

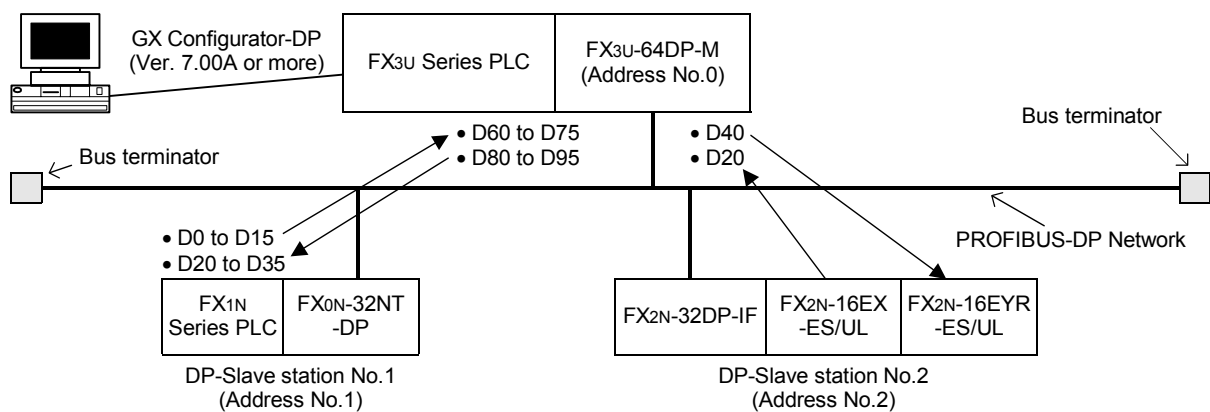

### 8.1.2 Contents of Operation

- D60 to D75 of DP-Master (FX3U PLC) is written in D0 to D15 of DP-Slave station 1 (FX1N PLC), and D20 to D35 of DP-Slave station 1 is written to D80 to D95 of DP-Master. In DP-Slave station 1, D0 is moved to D20 and D1 is moved to D21. Therefore, the value of D80 and D81 that was sent from DP-Master to DP-Slave station 1 returns to D60 and D61.
- D40 in DP-Master (FX3U PLC) is output to the FX2N-16EYR-ES/UL on the DP-Slave station 2 (FX2N-32DP-IF), and the input status of FX2N-16EX-ES/UL on the DP-Slave station 2 are read to D20 in DP-Master.
- When an error occurs on PROFIBUS-DP, the error status is stored in D290.
- When receiving Slave Diagnostic Information, the information is stored in D100 to D125.

### 8.1.3 Setting Network Configuration and Parameter for Example Program

When setting the network configuration and parameters for example program, use GX Configurator-DP Ver. 7.00A or later.

→ For operation of GX Configurator-DP, refer to the GX Configurator-DP Software Manual

#### Point

- 1) Module type  
Select the "PROFIBUS DP V1 (FX3U-64DP-M)" on "Network Setup" dialog box.
- 2) Download the project  
When making the project, download it to 64DP-M.  
→ For download operation details, refer to GX Configurator-DP Software Manual

## 1 Master Parameter Setting

Set the master parameter as follows in the "Master Setting" dialog box.

→ For details, refer to Section 7.1 and GX Configurator-DP Software Manual

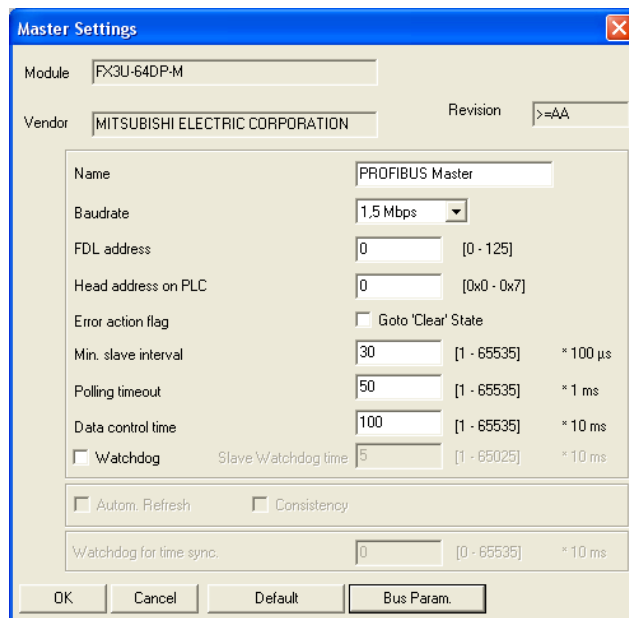

## 2 Bus Parameter Setting

Set the bus parameter as follows in the "Bus Parameter" dialog box.

→ For details, refer to Section 7.2 and GX Configurator-DP Software Manual

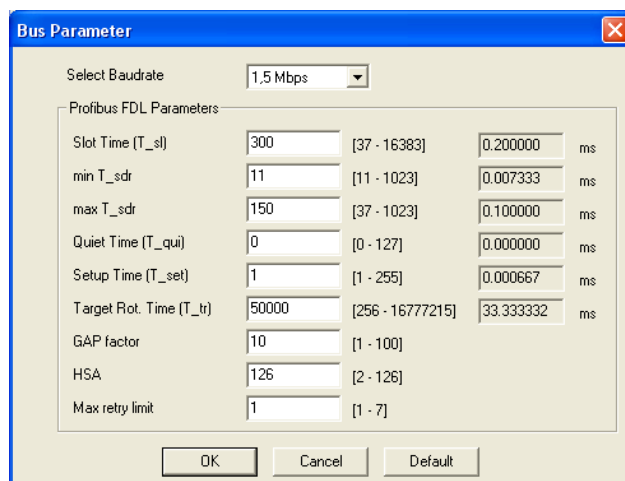

1

Introduction

2

Specifications

3

Installation

4

Wiring

5

Mode  
Data Comms.,  
Global Control

6

Allocation of  
Buffer Memories  
(BFMs)

7

Setting  
Parameters and  
Configuration

8

Example  
Program

9

Diagnostics

### 3 Network Configuration

Make network configuration as follows on "graphical network editor" window.

→ For operation details, refer to **GX Configurator-DP Software Manual**

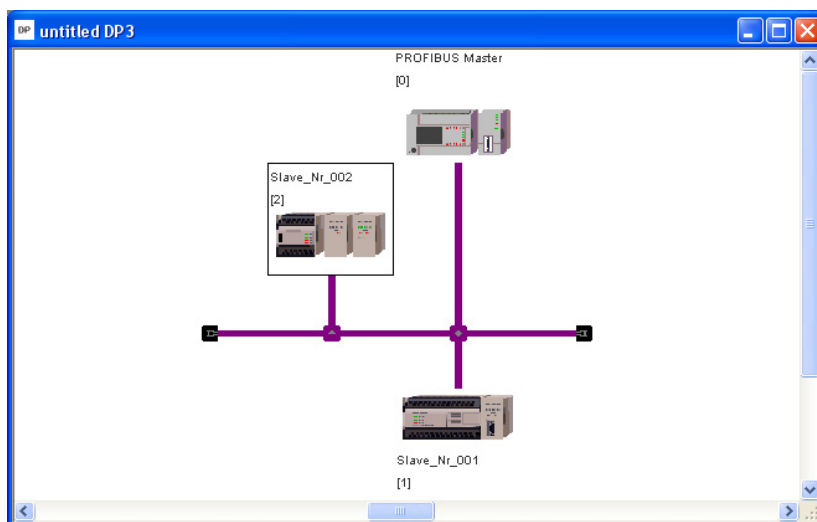

### 4 FX0N-32NT-DP Setting

→ For operation for **Module Configuration selection and Slave Parameter**, refer to **GX Configurator-DP Software Manual**

#### 1. Module Configuration Setting

Set the Module Configuration for FX0N-32NT-DP as follows in the "Slave Modules" dialog box.

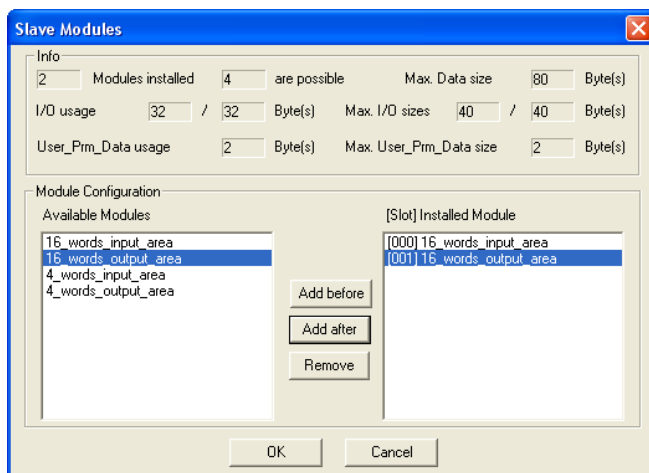

## 2. Slave Parameter Setting

Set the slave parameter for FX0N-32NT-DP as follows in the "Slave Parameter Settings" dialog box.

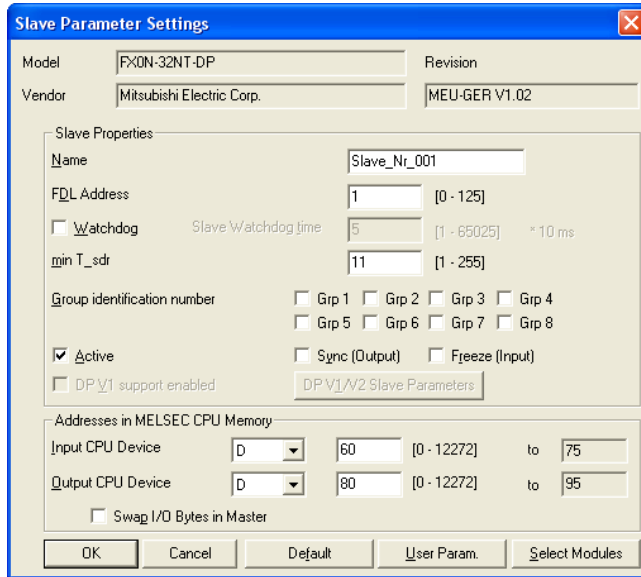

## 5 FX2N-32DP-IF Setting

→ For operation for Module Configuration selection and Slave Parameter, refer to GX Configurator-DP Software Manual

### 1. Module Configuration Setting

Set the Module Configuration for FX2N-32DP-IF as follows in the "Slave Modules" dialog box.

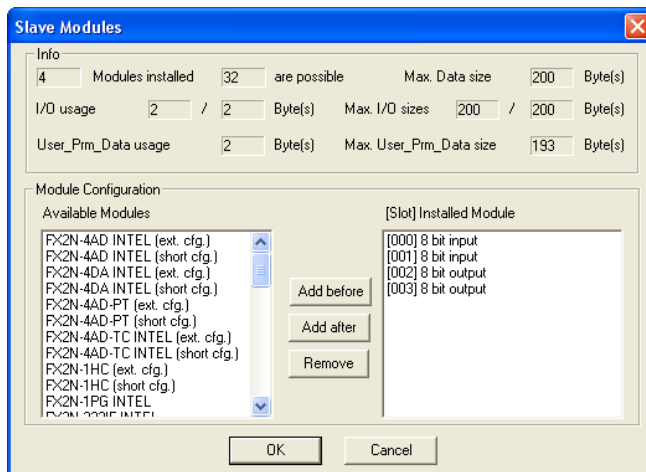

1

Introduction

2

Specifications

3

Installation

4

Wiring

5

Mode-Data Comms., Global Control

6

Allocation of Buffer Memories (BFMs)

7

Setting Parameters and Configuration

8

Example Program

9

Diagnostics

## 2. Slave Parameter Setting

Set the slave parameter for FX2N-32DP-IF as follows in the "Slave Parameter Settings" dialog box.

The screenshot shows the "Slave Parameter Settings" dialog box with the following configuration:

- Model: FX2N modular station V2.10
- Revision: (empty)
- Vendor: MITSUBISHI ELECTRIC CORP.
- Revision: 2.10
- Slave Properties:
  - Name: Slave\_Nr\_002
  - FDL Address: 2 [0 - 125]
  - Watchdog Slave Watchdog time: 5 [1 - 65025] \* 10 ms
  - min T\_sdr: 11 [1 - 255]
  - Group identification number:  Grp 1  Grp 2  Grp 3  Grp 4  Grp 5  Grp 6  Grp 7  Grp 8
  - Active  Sync (Output)  Freeze (Input)
  - DP V1 support enabled
- Addresses in MELSEC CPU Memory:
  - Input CPU Device: D [0 - 12287] to 20
  - Output CPU Device: D [0 - 12287] to 40
  - Swap I/O Bytes in Master

Buttons: OK, Cancel, Default, User Param., Select Modules

### 8.1.4 Example Program using GX Developer

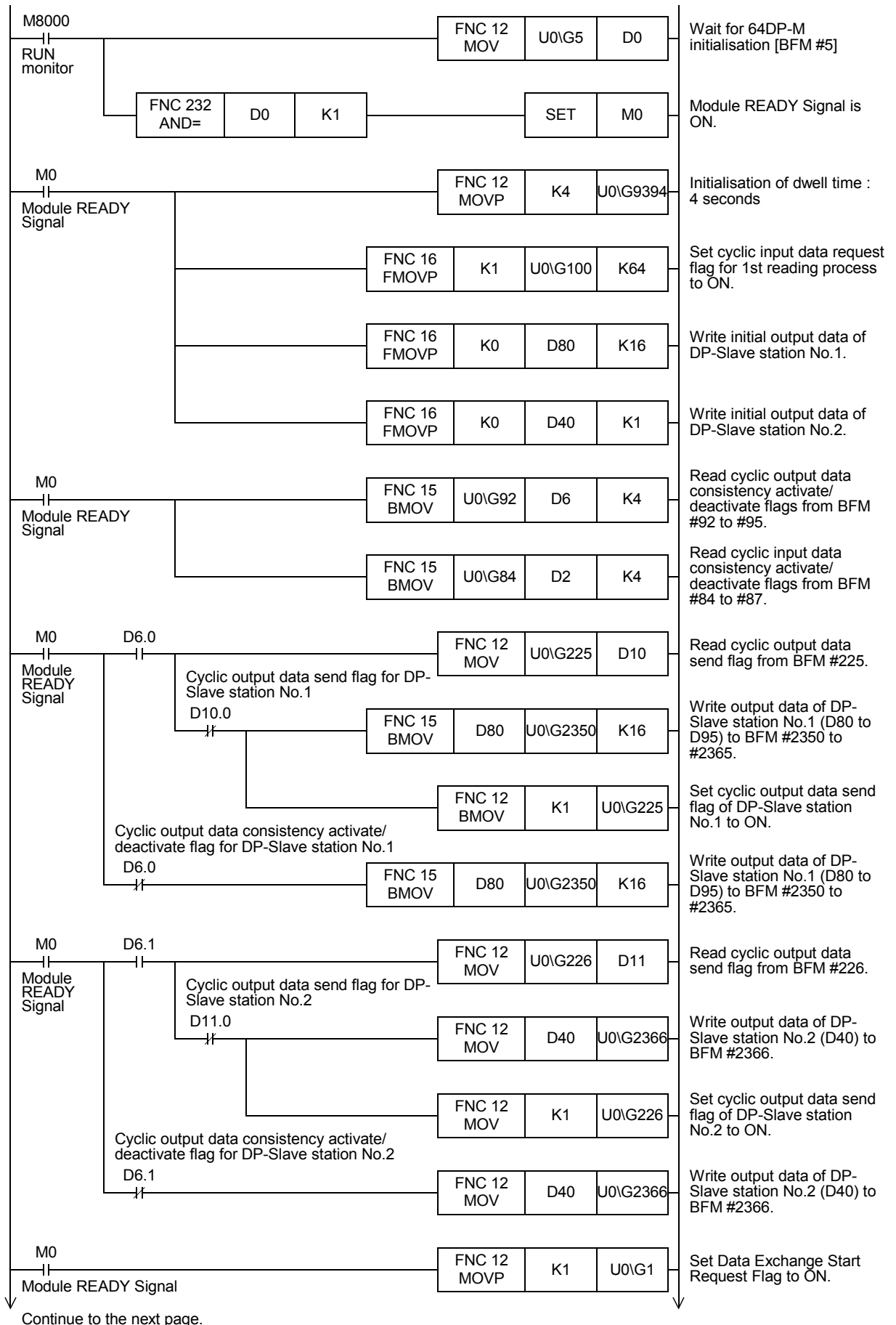

1	Introduction
2	Specifications
3	Installation
4	Wiring
5	Mode-Data Comms., Global Control
6	Allocation of Buffer Memories (BFMs)
7	Setting Parameters and Configuration
8	Example Program
9	Diagnostics

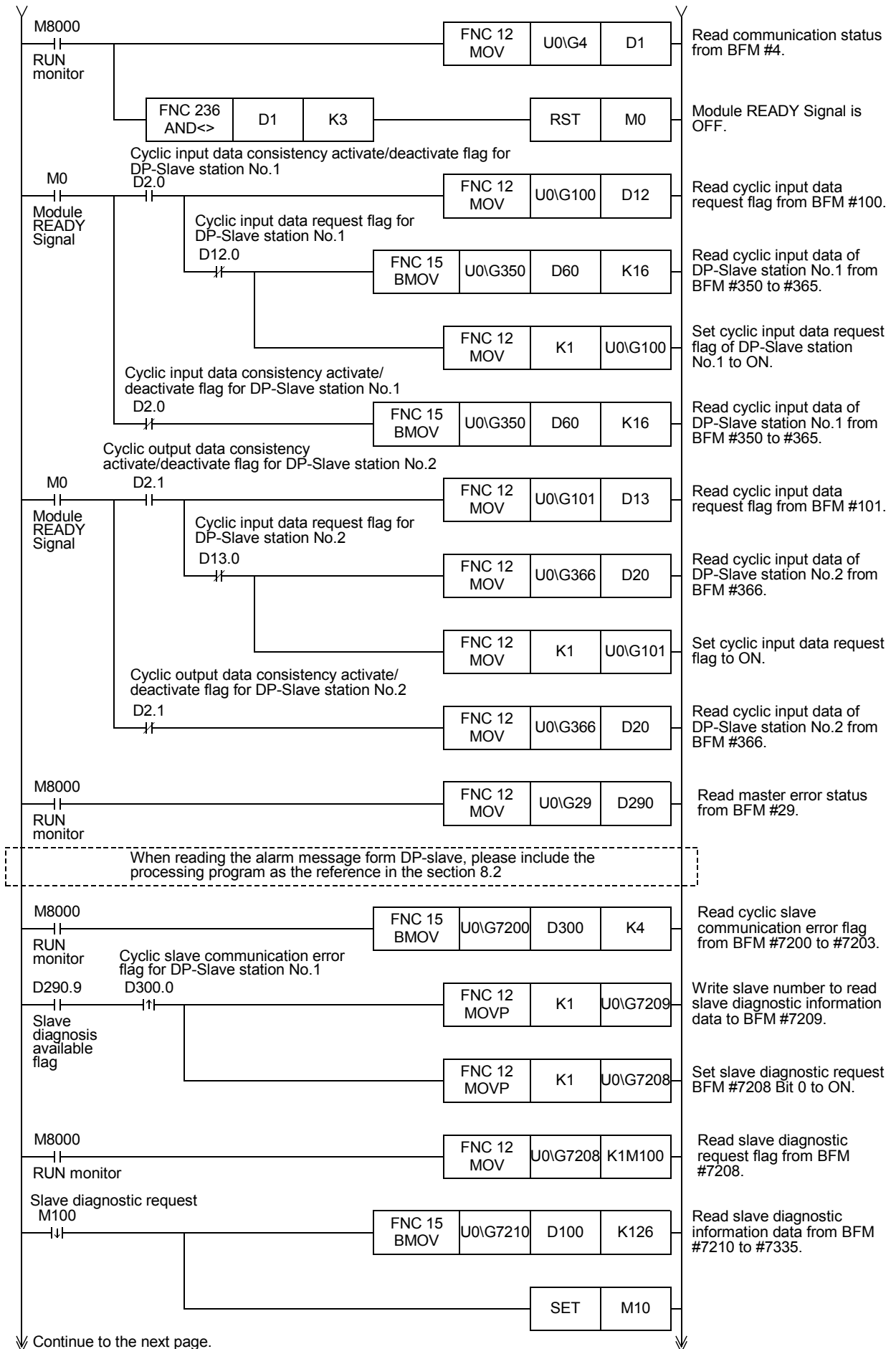



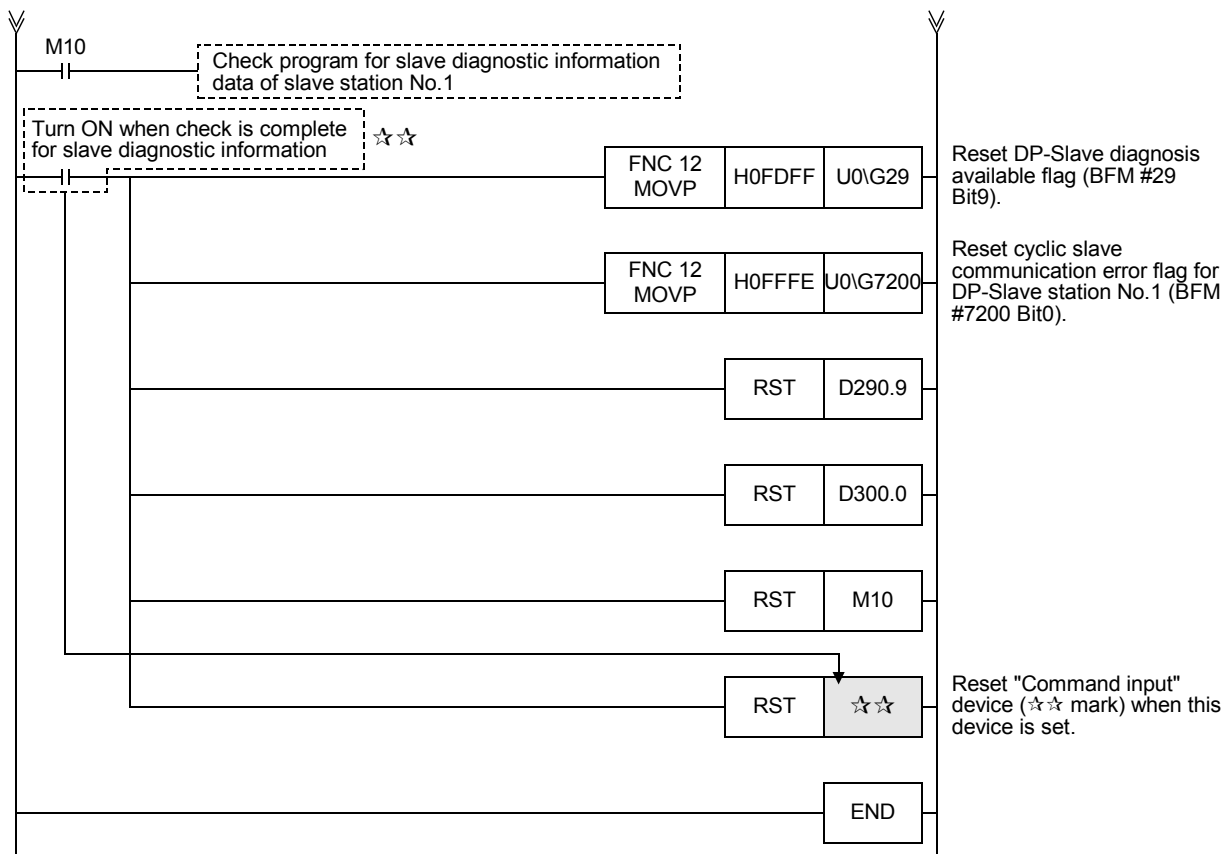

<b>1</b>	Introduction
<b>2</b>	Specifications
<b>3</b>	Installation
<b>4</b>	Wiring
<b>5</b>	Mode-Data Comms., Global Control
<b>6</b>	Allocation of Buffer Memories (BFMs)
<b>7</b>	Setting Parameters and Configuration
<b>8</b>	Example Program
<b>9</b>	Diagnostics

### 8.1.5 Example Program using GX IEC Developer (Ver. 7.00 or later)

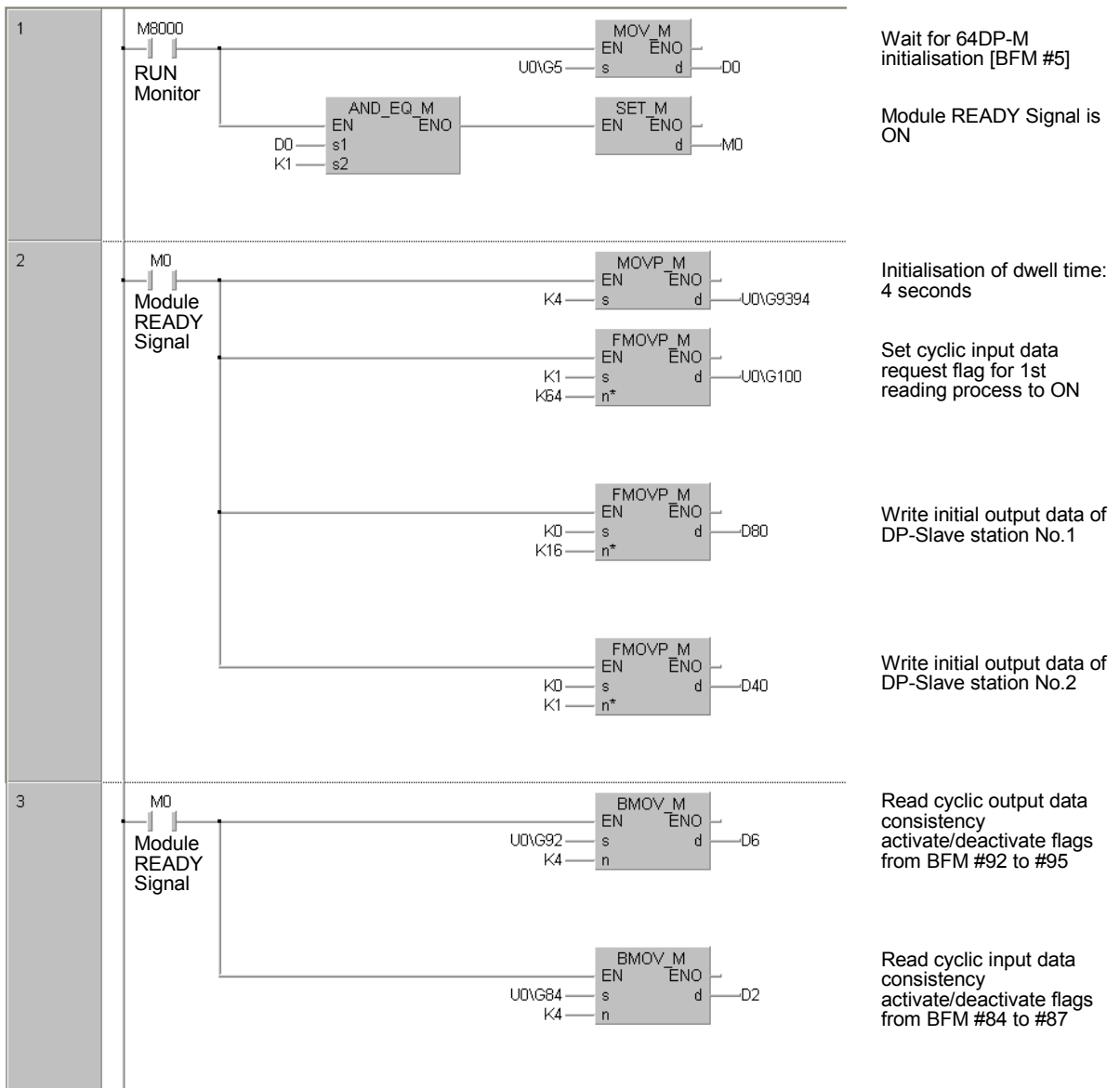

To the next page

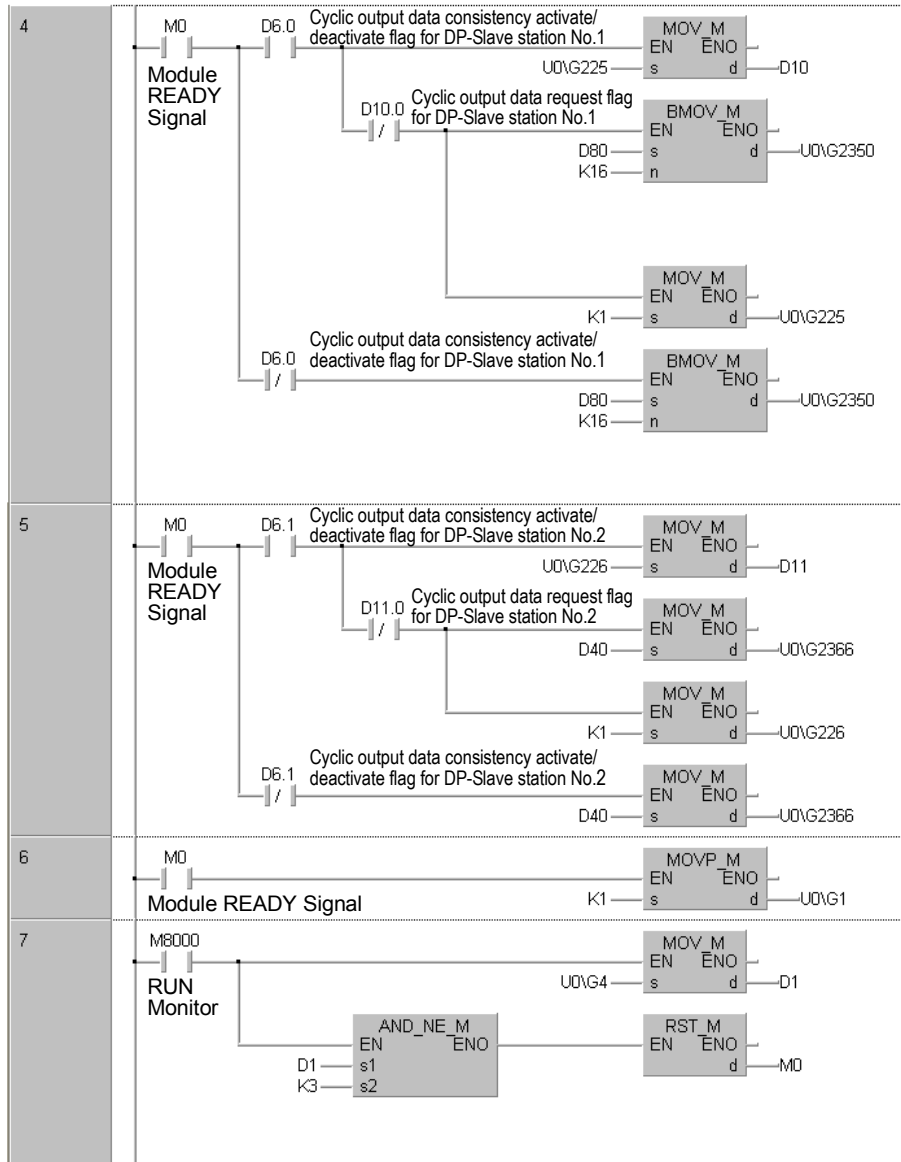

Read cyclic output data send flag from BFM #225

Write output data of DP-Slave station No.1 (D80 to D95) to BFM #2350 to #2365

Set cyclic output data send flag of DP-Slave station No.1 to ON

Write output data of DP-Slave station No.1 (D80 to D95) to BFM #2350 to #2365

Read cyclic output data send flag from BFM #226

Write output data of DP-Slave station No.2 (D40) to BFM #2366

Set cyclic output data send flag of DP-Slave station No.2 to ON

Write output data of DP-Slave station No.2 (D40) to BFM #2366

Set data exchange start request flag to ON

Read communication status from BFM #4

Module READY Signal is OFF



To the next page

1

Introduction

2

Specifications

3

Installation

4

Wiring

5

Mode-Data Comms., Global Control

6

Allocation of Buffer Memories (BFMs)

7

Setting Parameters and Configuration

8

Example Program

9

Diagnostics

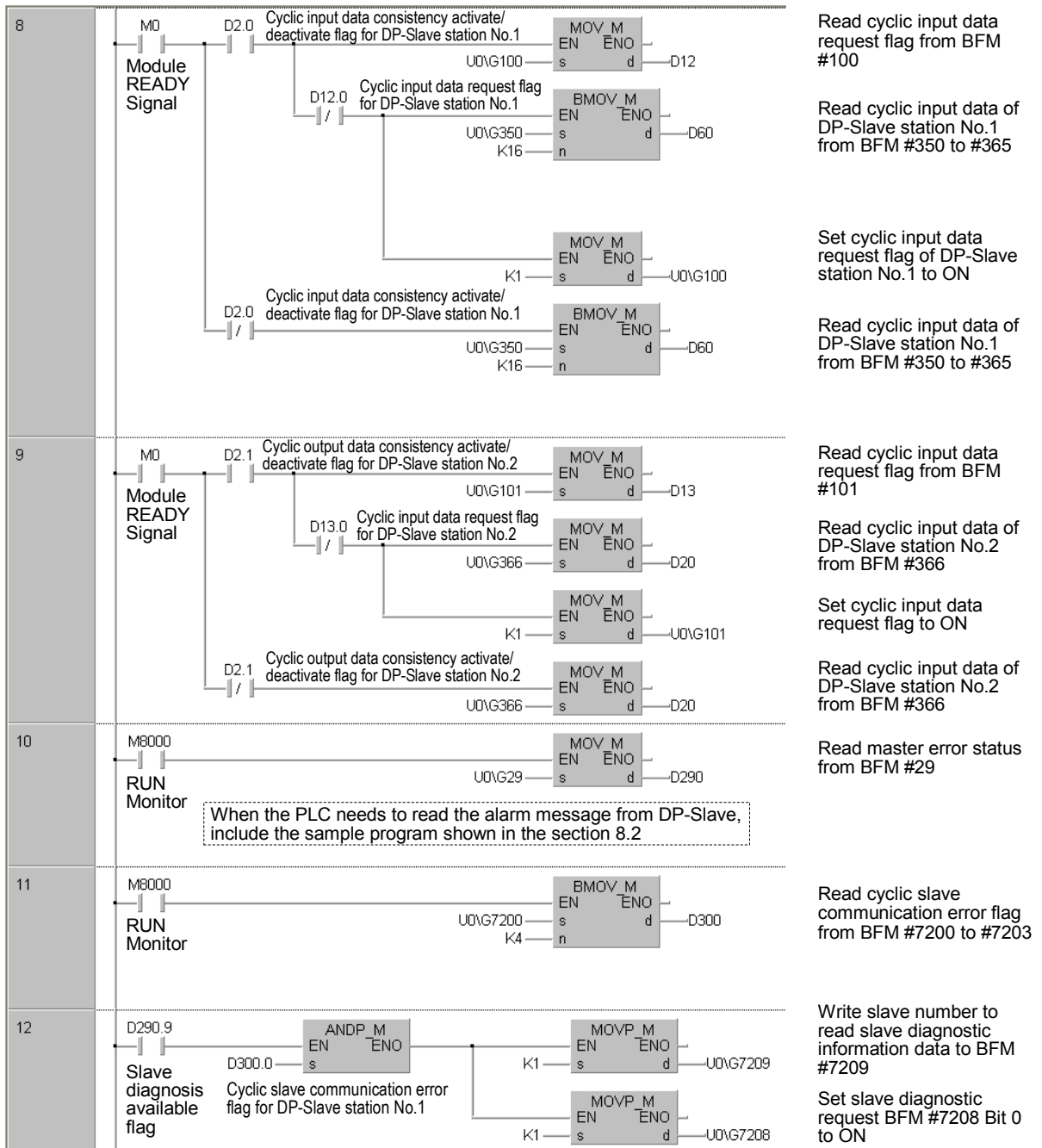

To the next page

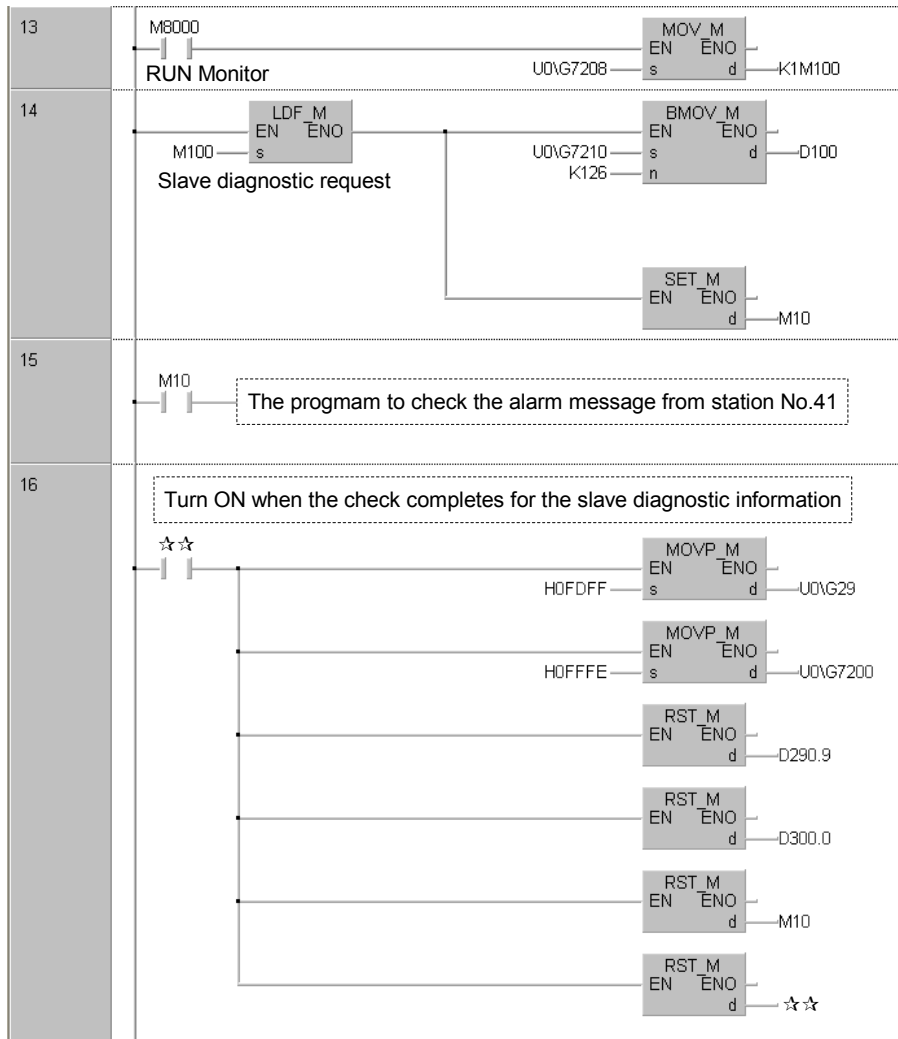

Read slave diagnostic request flag from BFM #7208

Read slave diagnostic information data from BFM #7210 to #7335

Write slave number to read slave diagnostic information data to BFM #7209

The program to check the alarm message from station No.41

Turn ON when the check completes for the slave diagnostic information

Reset DP-Slave diagnosis available flag (BFM #29 Bit 9)

Reset cyclic slave communication error flag for DP-Slave station No.1 (BFM #7200 Bit 0)

Reset "Command input" device (☆☆ mark) when this device is set

1

Introduction

2

Specifications

3

Installation

4

Wiring

5

Mode-Data Comms., Global Control

6

Allocation of Buffer Memories (BFMs)

7

Setting Parameters and Configuration

8

Example Program

9

Diagnostics

## 8.2 Example Programs to Read Alarm Message from PROFIBUS-DPV1 Slave (Alarm Model)

### 8.2.1 An Example Program using GX Developer

An example program using GX Developer is shown below, which reads Alarm Messages from the DP-Slave station No.41 using the automatic acknowledge function. The alarm message from the DP-slave is stored in D350 to D384. When inserting this program to the GX Developer example in Subsection 8.1.4, do not program the circled part with the ★ mark since it is redundant.

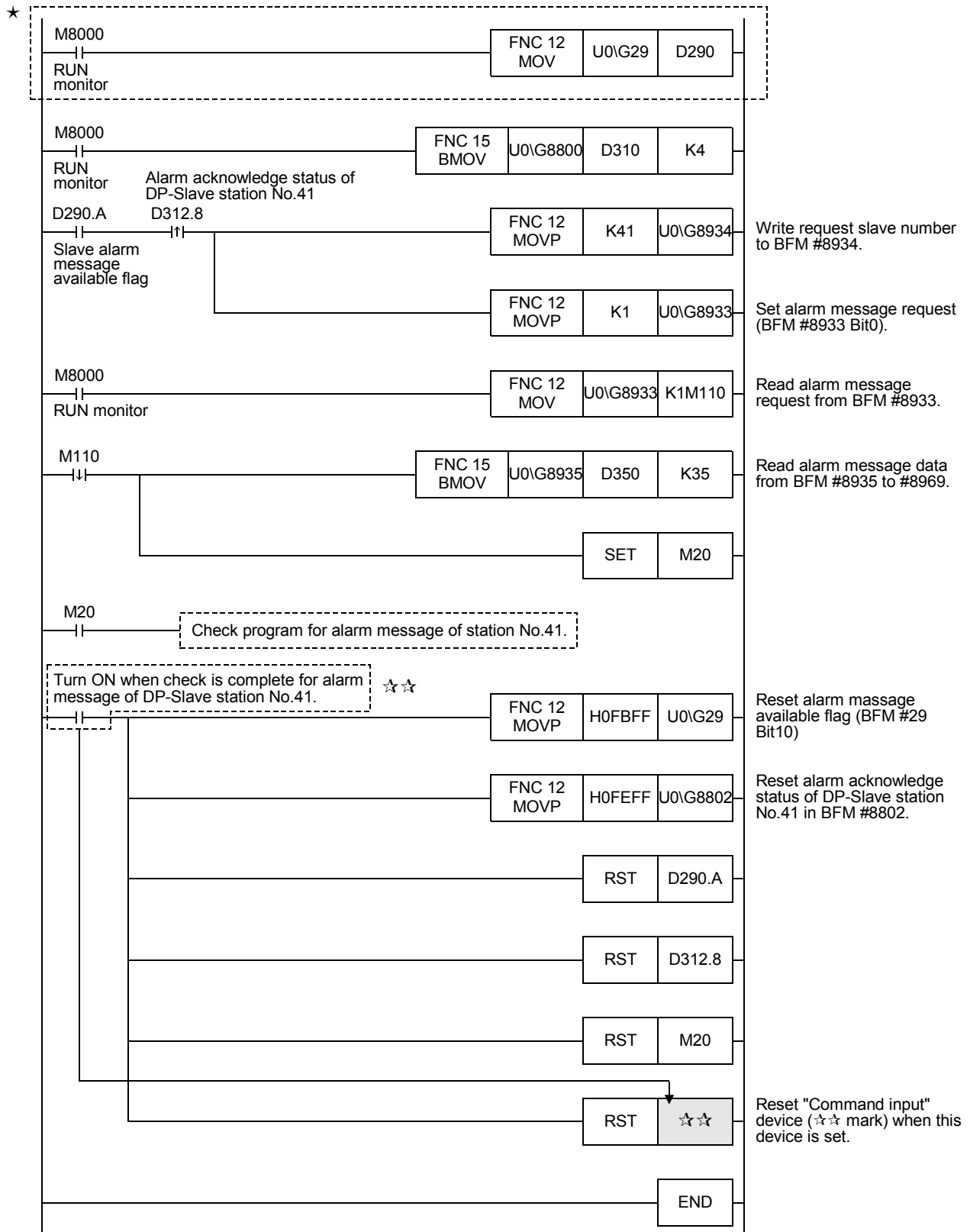

### 8.2.2 An Example Program using GX IEC Developer (Ver. 7.00 or later)

An example program by GX IEC Developer is shown below, which reads Alarm Messages from the DP-Slave station No.41 using the automatic acknowledge function. The alarm message from the DP-slave is stored in D350 to D384.

When inserting this program to the GX IEC Developer example in Subsection 8.1.5, do not include the PRG\_MAIN Body Network #1 below with the ★ mark since it is redundant.

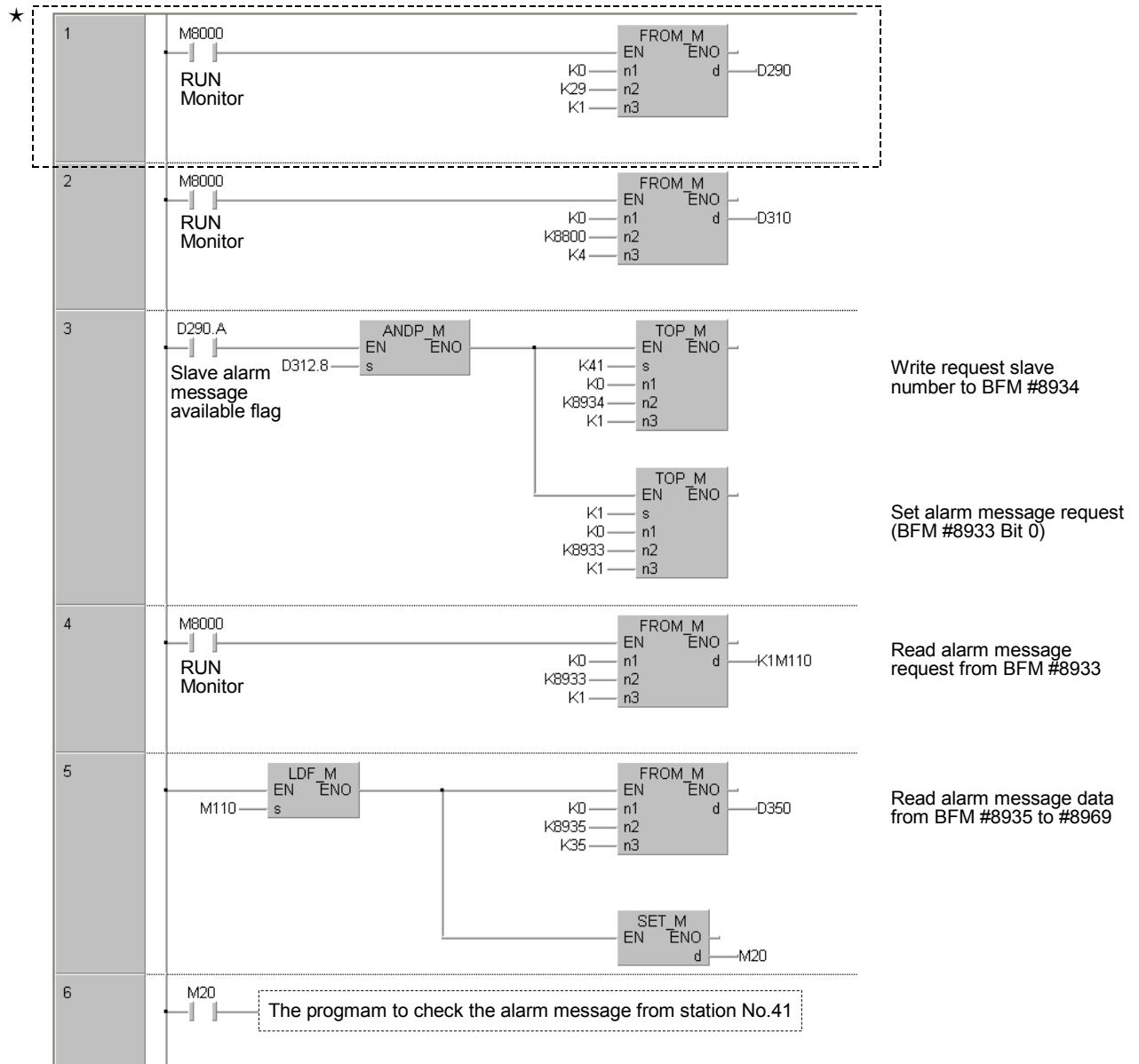

To the next page

1

Introduction

2

Specifications

3

Installation

4

Wiring

5

Mode-Data Comms., Global Control

6

Allocation of Buffer Memories (BFMs)

7

Setting Parameters and Configuration

8

Example Program

9

Diagnostics

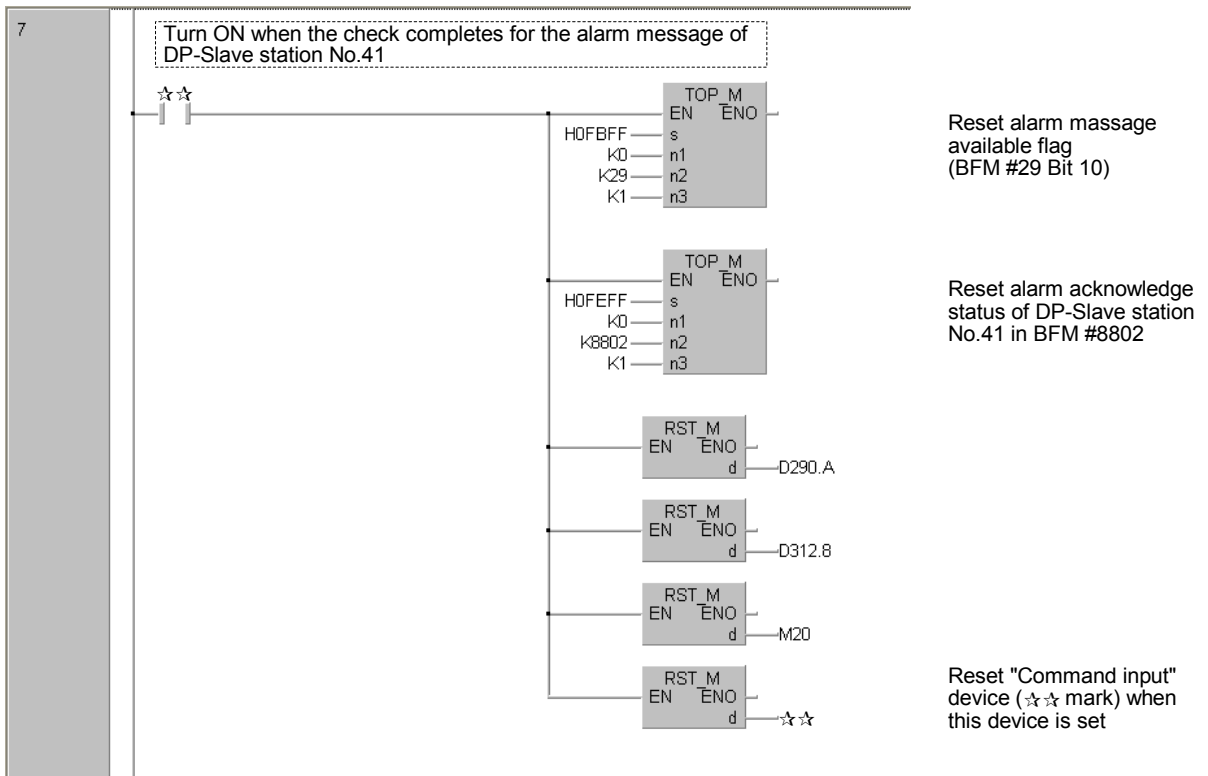



## 8.3 Initializing the Network

The Create POU functionality enables GX Configurator-DP to output an IL (Instruction List) Program from the user-configured network. Users can import this IL-Program to GX IEC Developer since it is fully compatible. This IL-Program has the same parameter settings for Data Registers (D), Auxiliary Relays (M) and Extension Registers (R), based on the user-configured network.

To import the IL-Program to GX IEC Developer, follow the procedures below. These procedures include [GX Configurator-DP Operations] and [GX IEC Developer Operations]. Make sure to complete the [GX Configurator-DP Operations] first.

The DP master can retrieve all slave I/O Data in a memory-efficient manner using a single FROM/TO instruction, thereby having only a small influence on the PLC cycle time.

### Primary procedures [GX Configurator-DP Operations]

- 1) Set the [Input CPU Device] and [Output CPU Device] in the [Slave Parameter Settings] dialog box, where users establish the cyclic data exchange.
- 2) Select [Actions] in the menu bar, and click [Create POU] to output an IL-Program based on the user-configured network. The extension of this IL-Program is <\*.asc>.
  - For details, Refer to Subsection 8.1.3
  - For GX Configurator-DP operations, refer to GX Configurator-DP Software manual

### The secondary procedures [GX IEC Developer Operations]

- 1) Create a new project in GX IEC Developer.
- 2) Select [Project] in the menu bar, and click [Other] → [Import].
  - For details, Refer to GX IEC Developer Reference Manual

### Note

- After finishing the import, the GX IEC Developer creates 2 new POUs, <Copy\_Pou> and <Profibus\_Init>, in the Project Navigator Window. The <Copy\_Pou> body text is composed of the IL-Program by the GX Configurator-DP, compiled for the cyclic communication with the PROFIBUS-DP master. If data consistency > 16bit is not necessary (for example, there are no 32bit counter), it is possible to copy the input/output data of all slaves with one FROM/TO in the PLC program. This can save a lot of PLC program memory, while having only a small influence on the PLC cycle time.
- The other POU in the Project Navigator Window, <Profibus\_Init>, is empty right after [Import]. To enable the communication with the PROFIBUS-DP master, users must complete this program as follows. (The program varies, depending on the user-configured network.)

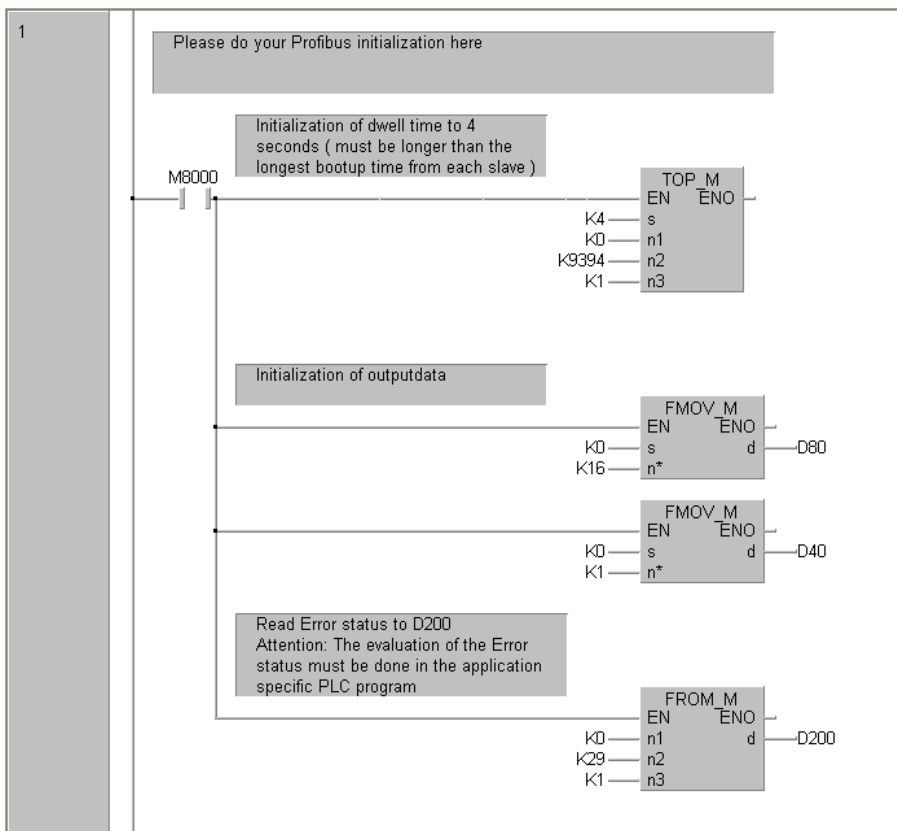

## 9. Diagnostics

### STARTUP AND MAINTENANCE PRECAUTIONS



- Do not touch any terminal while the PLC's power is on.  
Doing so may cause electric shock or malfunctions.
- Before cleaning or retightening terminals, externally cut off all phases of the power supply.  
Failure to do so may cause electric shock.
- Before modifying or disrupting the program in operation or running the PLC, carefully read through this manual and the associated manuals and ensure the safety of the operation.  
An operation error may damage the machinery or cause accidents.

### STARTUP AND MAINTENANCE PRECAUTIONS



- Do not disassemble or modify the unit.  
Doing so may cause fire, equipment failures, or malfunctions.  
\* For repair, contact your local Mitsubishi Electric distributor.
- Do not drop the product and exert strong impact. Doing so may cause damage.
- Turn off the power to the PLC before attaching or detaching the peripheral devices.  
Failure to do so may cause equipment failures or malfunctions.

### 9.1 Preliminary Checks

Check the POWER, RUN and ERROR LED status.

#### 1. POWER LED:

LED State	Description
Lit	The power is being correctly supplied from FX3U Series PLC via the extension cable to 64DP-M.
Otherwise	<p>The power is being incorrectly supplied from FX3U Series PLC via the extension cable to 64DP-M.</p> <ul style="list-style-type: none"> <li>• Check the connection of the extension cable to the PLC.</li> <li>• Check the power supply of the FX3U series PLC.</li> </ul> <p style="text-align: right;">→ <b>For FX3U Series PLC, refer to FX3U Hardware Edition</b> → <b>For power supply specifications for 64DP-M, refer to Section 2.2</b></p>

## 2. RUN LED:

LED State	Description
Lit	64DP-M is in normal operation. For data exchange, the RUN LED must be lit.
Flicker	Flickers in 500ms intervals. <ul style="list-style-type: none"> <li>The Dwell Time that was set in BFM #9394 is probably not expired yet. → <b>For Dwell Time Setting, refer to Section 6.35</b></li> <li>If at least one projected DP-Slave is not participating in cyclic data exchange, the RUN LED will continue to flicker. In this case the downloaded network configuration is probably different than the real network configuration (e.g. missing DP-Slaves, wrong Slave FDL addresses). To check the configuration discrepancies by PROFIBUS Scan Function, use the function of BFM #10052. → <b>For PROFIBUS Scan Function details, refer to Section 6.42</b></li> </ul>
Unlit	<ul style="list-style-type: none"> <li>The FX3U PLC switches to STOP mode, which will cause the master to also switch to STOP mode.</li> <li>The user program has not yet started communication by setting Data Exchange Start Request Flag (BFM #1 Bit 0) to ON. → <b>For BFM #1 details, refer to Section 6.3</b></li> <li>The user program has reset Data Exchange Start Request Flag (BFM #1 Bit 0) by mistake and has stopped the 64DP-M. → <b>For BFM #1 details, refer to Section 6.3</b></li> <li>A Hardware error or Network error has occurred. Check ERROR LED and contents of BFM #29. → <b>For details, refer to Section 9.2</b></li> </ul>

## 3. ERROR LED:

LED State	Description
Lit	A Hardware error or Network error has occurred. Check the Bit status in BFM #29. → <b>For details, refer to Section 9.2</b>
Flicker	Flickers in 500ms intervals. <ul style="list-style-type: none"> <li>If the ERROR LED starts flickering after 64DP-M switches to RUN mode: possibility that the Information Dwell Time (BFM #9394) setting value is too short. Try to increase the dwell time setting. The reason for this behavior might be that there is a DP-Slave in the network that requires a longer time for booting. → <b>For Dwell Time Setting, refer to Section 6.35</b></li> <li>If the ERROR LED starts flickering after the FX3U main unit switches to RUN mode: There might be a mistake in the user program. In case of an attempt to access a write protected BFM or in case of a data consistency handling error, the LED will also start flickering. Check details of BFM #29. → <b>For details, refer to Section 9.2</b></li> <li>If the ERROR LED flickers, at least one DP-Slave might have reported an error to the DP-master (diagnostic information). Check details of BFM #29. → <b>For details, refer to Section 9.2</b> → <b>For Slave Diagnostic Information details, refer to Section 6.29 and 6.30</b></li> </ul>
Unlit	64DP-M is in normal operation.

### Note

A data consistency handling error can also occur if the BFM that contains the slave data requiring consistency handling is monitored with the BFM monitor of the programming Software (i. e. GX Developer).

1

Introduction

2

Specifications

3

Installation

4

Wiring

5

Mode-Data Comms., Global Control

6

Allocation of Buffer Memories (BFMs)

7

Setting Parameters and Configuration

8

Example Program

9

Diagnostics

## 9.2 Detail Error Check

---

Please check the bit status in Master Error Status BFM #29.

### 1. Master Reset Status Flag [BFM #29 Bit 0]

This flag is set to ON after 64DP-M software is reset by Master Reset BFM #27 and after Configuration is download from GX Configurator-DP. It will be reset by writing K0 and after the Mode changes from STOP to RUN.

→ For Master Reset details, refer to Section 6.11

### 2. Master Hardware Error [BFM #29 Bit 1]

This bit is set to ON if the Hardware has an error (Module is probably damaged). Please consult the nearest Mitsubishi Electric distributor.

### 3. Slave Parameter Error [BFM #29 Bit 3]

This flag is set to ON if 64DP-M has received a parameter error from a DP-Slave. The DP-Slaves which reported parameter errors are listed in BFM #7000 to #7003. The detailed reason for the parameter error is listed in BFM #7008 to #7071. There is a probability that the GSD file for the DP-Slave imported into GX Configurator-DP is corrupt. (Please check for an updated version with the vendor of the DP-Slave).

→ For Master/Slave Internal Slave Parameter Error Flag BFM #7000 to #7003, refer to Section 6.27

→ For Master/Slave Internal Slave Parameter Error Data BFM #7008 to #7071, refer to Section 6.28

### 4. Setting Error Flag [BFM #29 Bit 4]

This flag is ON if the user accesses FROM/TO instructions, etc. from a protected BFM, or if there is an invalid entry written into a BFM. Check BFM #28 for further details.

The reason for this error can be a mistake in the user program or an access to the BFM area by the entry data monitor function of the Programming software (i. e. GX Developer).

→ For Master Status BFM #28, refer to Section 6.12

### 5. Consistency Error Flag [BFM #29 Bit 5]

This flag is ON if an error has occurred in the data consistency handling. This bit reflects the status of BFM #2. If any of the bits in BFM #2 is set to ON, BFM #29 Bit 5 is also set to ON. Check BFM #2 for details. The reason for this error can be a mistake in the user PLC program or an access to the BFM area by the entry data monitor function of the Programming software (i. e. GX Developer).

→ For Consistency Handling Error Flag BFM #2, refer to Section 6.4

### 6. Acyclic Communication Deactivation Message Flag [BFM #29 Bit 7]

This flag is ON if there is a shutdown of the acyclic communication channel with a DP-Slave. One countermeasure to prevent this problem might be to increase the watchdog time for the DP-Slaves to stop the acyclic communication.

### 7. PROFIBUS Error Flag [BFM #29 Bit 8]

This flag is ON if there is a PROFIBUS problem. More details are displayed in BFM #3.

If this error occurs, check the wiring of the PROFIBUS network. Reasons can be the short circuit of communication lines, unmatching network bus terminators, or an excessive Bus length for the selected baud rate. Reduce the communication baud rate in GX Configurator-DP. If the network is segmented by repeaters, every segment must also be properly built up with termination resistors.

→ For PROFIBUS Error Flag BFM #3, refer to Section 6.5

#### Attention

---

If this error occurs while the 64DP-M is in cyclic data exchange (RUN) mode, the 64DP-M will automatically change to STOP/Offline mode unless BFM #34 Bit 0 is ON.

### 8. Slave Diagnostic Available [BFM #29 Bit 9]

This flag is ON if a DP-Slave sends a diagnostic message. If any of the bits in BFM #7200 to #7203 is set to ON, BFM #29 Bit 9 is also set to ON. If this error occurs, check the reason for the DP-Slave diagnostic by checking the manual of the DP-Slave. The content of the DP-Slave's diagnostic can be read out by using BFM #7208 to #7335.

→ For Slave Diagnostic Information, refer to Section 6.29

### 9. Alarm Message Available Flag [BFM #29 Bit 10]

This flag is ON if a DP-Slave sends an alarm message. If any of the bits in BFM #8800 to #8803 is set to ON, BFM #29 Bit 10 is also set to ON. If this error occurs, check the reason for the DP-Slave alarm by checking the users manual of the DP-Slave. The content of the DP-Slave's alarm can be read out by using BFM #8934 to #8969.

→ For Alarm Message, refer to Section 6.32

### 10.No Configuration Available Flag [BFM #29 Bit 11]

This flag is ON if there is no configuration stored in the PROFIBUS Master. A default bus configuration without any projected DP-Slaves will be loaded. The default baud rate is 93.75 kbps and default address is 0. Other default parameter data are matched accordingly. This error can be corrected if there is a complete configuration downloaded to the DP-Master from GX Configurator-DP.

### 11.Mode Change Not Possible Flag [BFM #29 Bit 12]

This flag is ON when the Operation Service Mode can not change from 3 to 0 by writing to BFM #39. If at least one input or output area of a DP-Slave is greater than 32 bytes, the error will occur because this data length is too larger for Mode 0. (in mode 0, I/O data length is 32 bytes or less.) In this error case, download the configuration that changed the I/O data length to 32 bytes or less on the DP-Slave configuration in GX Configurator-DP. However this data length configuration is not possible for every DP-Slave. In this case service mode 3 has to be used.

→ For Operation Service Mode BFM #39, refer to Section 6.20

### 12.Diagnostic FIFO Is Full [BFM #29 Bit 13]

This flag is ON if the Diagnosis FIFO already contains 64 entries. When BFM #29 Bit 13 resets, Diagnostic FIFO Information will be cleared in one step. This Flag will also be reset after changing from STOP to RUN mode.

If this Bit is ON, 64DP-M can not stock the next Slave Diagnostic Information into Internal Diagnostic FIFO Area until this bit is OFF.

→ For Diagnostic Information FIFO, refer to Section 6.30

#### Note

To clear this flag, execute the following 3 methods.

- Change modes from STOP to RUN. (Changes value in BFM #1 from K0 to K1)
- Reset (Clear) Internal FIFO Counter BFM #7337. (Writes K0 to BFM #7337)
- Reset Diagnostic FIFO Full flag BFM #29 Bit 13 when this bit is ON.

### 13.Data Exchange Error [BFM #29 Bit 14]

This flag shows a data exchange interruption of a DP-Slave. For example, this error will occur, if a DP-Slave is removed from the network during cyclic data exchange by a loose cable connection or a watchdog timer error from a DP-Slave.

If the networking cable is installed in an area of extreme electromagnetical noise, sometimes this error will occur. To avoid effect from extreme electromagnetical noise, lay the network cable in a different cable duct without high voltage cables and far from to other sources of electromagnetic noise.

#### Attention:

When it is necessary to the application that communication not continue during this error, the "Error Action Flag" should be selected to "Goto Clear Flag" in GX Configurator DP (Master Settings). Additionally the watchdog timer for the cyclic communication with the DP-Slaves should be set.

### 14.Slave Change Address Error [BFM #29 Bit 15]

The change Slave FDL Address function BFM #81-#83 can only be used if the DP-Master is in STOP mode (BFM #0 = K0). If the change of a Slave FDL Address was not successful, this error will occur. Reasons for this error can be that the specified Slave FDL Address does not exist on the network, or the DP-Slave is not supporting the address change function.

Check the Slave FDL Addresses on the network by using the PROFIBUS Scan Function.

To check whether or not the DP-Slave is supporting this function, please see DP-Slave's manual.

→ For Change Slave FDL Address BFM #81 to #83, refer to Section 6.22

→ For PROFIBUS Scan Function details, refer to Section 6.42

1

Introduction

2

Specifications

3

Installation

4

Wiring

5

Mode-Data Comms., Global Control

6

Allocation of Buffer Memories (BFMs)

7

Setting Parameters and Configuration

8

Example Program

9

Diagnostics

## MEMO

## Warranty

Please confirm the following product warranty details before using this product.

### 1. **Gratis Warranty Term and Gratis Warranty Range**

If any faults or defects (hereinafter "Failure") found to be the responsibility of Mitsubishi occurs during use of the product within the gratis warranty term, the product shall be repaired at no cost via the sales representative or Mitsubishi Service Company. However, if repairs are required onsite at domestic or overseas location, expenses to send an engineer will be solely at the customer's discretion. Mitsubishi shall not be held responsible for any re-commissioning, maintenance, or testing on-site that involves replacement of the failed module.

#### **[Gratis Warranty Term]**

The gratis warranty term of the product shall be for one year after the date of purchase or delivery to a designated place. Note that after manufacture and shipment from Mitsubishi, the maximum distribution period shall be six (6) months, and the longest gratis warranty term after manufacturing shall be eighteen (18) months. The gratis warranty term of repair parts shall not exceed the gratis warranty term before repairs.

#### **[Gratis Warranty Range]**

- 1) The range shall be limited to normal use within the usage state, usage methods and usage environment, etc., which follow the conditions and precautions, etc., given in the instruction manual, user's manual and caution labels on the product.
- 2) Even within the gratis warranty term, repairs shall be charged for in the following cases.
  - a) Failure occurring from inappropriate storage or handling, carelessness or negligence by the user. Failure caused by the user's hardware or software design.
  - b) Failure caused by unapproved modifications, etc., to the product by the user.
  - c) When the Mitsubishi product is assembled into a user's device, Failure that could have been avoided if functions or structures, judged as necessary in the legal safety measures the user's device is subject to or as necessary by industry standards, had been provided.
  - d) Failure that could have been avoided if consumable parts (battery, backlight, fuse, etc.) designated in the instruction manual had been correctly serviced or replaced.
  - e) Relay failure or output contact failure caused by usage beyond the specified Life of contact (cycles).
  - f) Failure caused by external irresistible forces such as fires or abnormal voltages, and failure caused by force majeure such as earthquakes, lightning, wind and water damage.
  - g) Failure caused by reasons unpredictable by scientific technology standards at time of shipment from Mitsubishi.
  - h) Any other failure found not to be the responsibility of Mitsubishi or that admitted not to be so by the user.

### 2. **Onerous repair term after discontinuation of production**

- 1) Mitsubishi shall accept onerous product repairs for seven (7) years after production of the product is discontinued.  
Discontinuation of production shall be notified with Mitsubishi Technical Bulletins, etc.
- 2) Product supply (including repair parts) is not available after production is discontinued.

### 3. **Overseas service**

Overseas, repairs shall be accepted by Mitsubishi's local overseas FA Center. Note that the repair conditions at each FA Center may differ.

### 4. **Exclusion of loss in opportunity and secondary loss from warranty liability**

Regardless of the gratis warranty term, Mitsubishi shall not be liable for compensation of damages caused by any cause found not to be the responsibility of Mitsubishi, loss in opportunity, lost profits incurred to the user or third person by Failures of Mitsubishi products, special damages and secondary damages whether foreseeable or not, compensation for accidents, and compensation for damages to products other than Mitsubishi products, replacement by the user, maintenance of on-site equipment, start-up test run and other tasks.

### 5. **Changes in product specifications**

The specifications given in the catalogs, manuals or technical documents are subject to change without prior notice.

### 6. **Product application**

- 1) In using the Mitsubishi MELSEC programmable logic controller, the usage conditions shall be that the application will not lead to a major accident even if any problem or fault should occur in the programmable logic controller device, and that backup and fail-safe functions are systematically provided outside of the device for any problem or fault.
- 2) The Mitsubishi programmable logic controller has been designed and manufactured for applications in general industries, etc. Thus, applications in which the public could be affected such as in nuclear power plants and other power plants operated by respective power companies, and applications in which a special quality assurance system is required, such as for Railway companies or Public service purposes shall be excluded from the programmable logic controller applications.  
In addition, applications in which human life or property that could be greatly affected, such as in aircraft, medical applications, incineration and fuel devices, manned transportation, equipment for recreation and amusement, and safety devices, shall also be excluded from the programmable logic controller range of applications.  
However, in certain cases, some applications may be possible, providing the user consults their local Mitsubishi representative outlining the special requirements of the project, and providing that all parties concerned agree to the special circumstances, solely at the users discretion.

## Revised History

Date	Revision	Discription
8/2005	A	First Edition
4/2006	B	FROM/TO Cycle Time and PROFIBUS Cycle Time charts added [Subsection 1.4.1, 1.4.2] Example programs using GX IEC Developwer added [Chapter 8] Program-importing procedures from GX Configurator-DP to GX IEC Developer added [Chapter 8]





**USER'S MANUAL**

**FX3U-64DP-M PROFIBUS-DP Master Block**



HEAD OFFICE: TOKYO BUILDING, 2-7-3 MARUNOUCHI, CHIYODA-KU, TOKYO 100-8310, JAPAN  
HIMEJI WORKS: 840, CHIYODA CHO, HIMEJI, JAPAN