



PROGRAMMABLE CONTROLLERS
MELSEC-F

FX_{2N}

FX_{2N}-10PG PULSE GENERATOR BLOCK

INSTALLATION MANUAL

JY992D91901D

This manual contains text, diagrams and explanations which will guide the reader in the correct installation, safe use and operation of the FX_{2N}-10PG PULSE GENERATOR BLOCK and should be read and understood before attempting to install or use the unit. Further information can be found in the manuals listed under further information.

Specifications are subject to change without notice

Guidelines for the Safety of the User and Protection of FX_{2N}-10PG PULSE GENERATOR BLOCK

This manual has been written to be used by trained and competent personnel. The definition of such a person or persons is as follows:

- Any engineer using the product associated with this manual, should be of a competent nature, trained and qualified to the local and national standards. These engineers should be fully aware of all aspects of safety with regards to automated equipment.
- Any commissioning or service engineer must be of a competent nature, trained and qualified to the local and national standards.
- All operators of the completed equipment should be trained to use that product in a safe and coordinated manner in compliance to established safety practices.

Note: The term 'completed equipment' refers to a third party constructed device which contains or uses the product associated with this manual.

Note's on the Symbols Used in this Manual

At various times through out this manual certain symbols will be used to highlight points of information which are intended to ensure the users personal safety and protect the integrity of equipment.



1) Indicates that the identified danger **WILL** cause physical and property damage.



2) Indicates that the identified danger could **POSSIBLY** cause physical and property damage.

- Under no circumstances will Mitsubishi Electric be liable responsible for any consequential damage that may arise as a result of the installation or use of this equipment.
- All examples and diagrams shown in this manual are intended only as an aid to understanding the text, not to guarantee operation. Mitsubishi Electric will accept no responsibility for actual use of the product based on these illustrative examples.
- Owing to the very great variety in possible application of this equipment, you must satisfy yourself as to its suitability for your specific application.

Further Information Manual Lists

Manual name	Manual No.	Description
FX _{2N} -10PG USER'S MANUAL	JY992D93401	Describes specifications, wiring, installation, handling, etc. of FX _{2N} -10PG.
FX _{2N} HARDWARE MANUAL	JY992D66301	Describes contents related to hardware of FX _{2N} series PLC such as specifications, wiring and installation.
FX _{3U} Series User's Manual - Hardware Edition	JY997D16501	Describes the specification, wiring and installation of FX _{3U} series PLC.
FX _{2NC} HARDWARE MANUAL	JY992D76401	Describes contents related to hardware of FX _{2NC} series PLC such as specifications, wiring and installation.
FX _{3UC} Series User's Manual - Hardware Edition	JY997D28701	Describes the specification, wiring and installation of FX _{3UC} series PLC.
FX SERIES PROGRAMMING MANUAL II	JY992D88101	Describes instructions of FX _{1S} /FX _{1N} /FX _{2N} /FX _{2NC} series PLC
FX _{3S} /FX _{3G} /FX _{3GC} / FX _{3U} /FX _{3UC} Series Programming Manual - Basic & Applied Instruction Edition	JY997D16601	This manual explains the installations of FX _{3S} /FX _{3G} / FX _{3GC} /FX _{3U} /FX _{3UC} series PLC.

1. Introduction

The FX_{2N}-10PG pulse generator block (Hereafter referred to as "FX_{2N}-10PG" or "pulse generator block") outputs pulses of 1MHz or less. It is a special function block to drive amplifiers for servo motors or stepper motors. It is connected to an FX_{2N}/FX_{2NC}/FX_{3U}/FX_{3UC} series Programmable controller (Hereafter referred to as "PLC") and used.

1.1 Features of the FX_{2N}-10PG

- 1) Positioning control with a stepper motor or servo motor.
(1 FX_{2N}-10PG can control 1 positioning axis.)
- 2) Can be connected to an FX_{2N}/FX_{2NC}/FX_{3U}/FX_{3UC} series PLC.
Data is read/written using FROM/TO instructions.
- 3) Pulses at up to 1MHz can be output.

1.2 External Dimensions and Each Part Name

Dimensions: mm (inches)

MASS (Weight): Approx. 0.2kg (0.44 lbs)

Accessory: Special block No. label

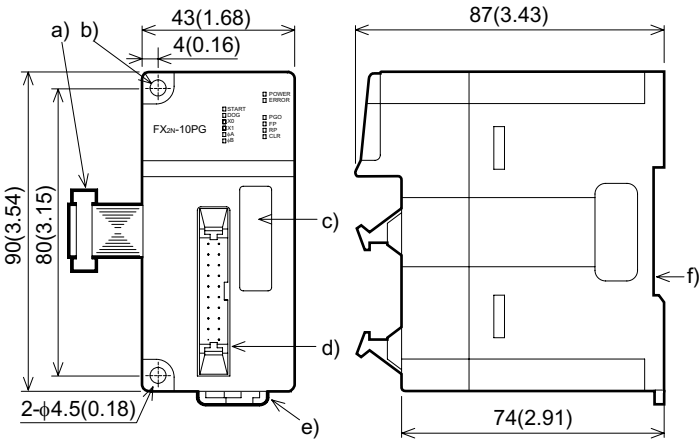

- a) Extension cable and connector
- b) Mounting hole 2-φ4.5(0.18inch)
- c) Extension port
- d) I/O port
- e) DIN rail clip
- f) Attachment groove for 35mm(1.38inch) wide DIN rail

1.3 LED display

LED name	State	Content of display
POWER	OFF	No 5V DC power from PLC main unit by way of the extension cable.
	Lit	5V DC is fed from the PLC main unit by way of the extension cable.
START	OFF	START input OFF.
	Lit	START input ON.
ERROR	OFF	Normal operation.
	Blinking	Error has occurred.
	Lit	CPU error
FP	OFF	Forward pulse or pulses not output.
	Blinking	Forward pulse or pulses output.
RP	OFF	Reverse pulse or direction command not output.
	Blinking or lit	Reverse pulse or direction command output.
CLR	OFF	CLR signal idle.
	Lit	CLR signal output (It completes Home position return).
DOG	OFF	DOG input OFF.
	Lit	DOG input ON.
PG0	OFF	Zero point signal input OFF.
	Lit	Zero point signal input ON.
φA	OFF	A phase input of manual pulse generator OFF.
	Blinking	A phase input of manual pulse generator ON.
φB	OFF	B phase input of manual pulse generator OFF.
	Blinking	B phase input of manual pulse generator ON.
X0,X1	OFF	Interrupt input OFF.
	Lit	Interrupt input ON.

1.4 Array and allocation of pin

I/O port

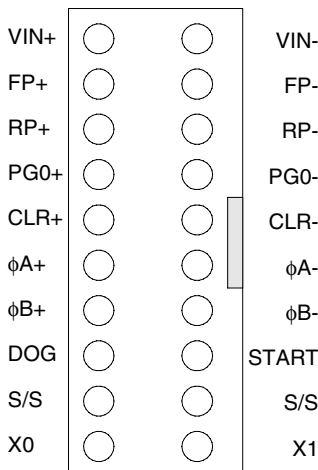

Terminal name	Content
VIN+	Power supply input terminal for pulse output (5 to 24V DC)
FP+	<ul style="list-style-type: none"> • Forward/reversal mode Forward pulse output terminal • Pulse/direction mode Pulse output terminal
RP+	<ul style="list-style-type: none"> • Forward/reversal mode Reversal pulse output terminal • Pulse/direction mode Direction output terminal
PG0+	Zero point signal input terminal
CLR+	Output terminal to clear collecting deflection counter pulse of servo amplifier
φA+	A phase input terminal of manual pulse generator
φB+	B phase input terminal of manual pulse generator
DOG	DOG input terminal
S/S	Power supply input terminal (START,DOG,X0,X1) (24V DC) Pins (S/S) are short-circuited internally
X0	Interruption input terminal
VIN-	Common terminal for VIN+
FP-	Common terminal for FP+
RP-	Common terminal for RP+
PG0-	Common terminal for PG0+
CLR-	Common terminal for CLR+
φA-	Common terminal of A phase input for manual pulse generator
φB-	Common terminal of B phase input for manual pulse generator
START	START input terminal
X1	Interruption input terminal

2. System configuration

The FX2N-10PG connects on the right side of a PLC main unit or extension unit/block (including special function blocks).

FX2N-10PG connects by extension cable from the PLC main unit.

(It is not possible to use the FX2N-10PG as a stand alone unit)

FX2N-10PG is a special function block. A special function unit number 0-7 is automatically assigned from the PLC corresponding to its location on the communication.*1

(Specified by FROM/TO instruction)

The FX2N-10PG occupies eight points of I/O.

Refer to the hardware manual of the connected main unit

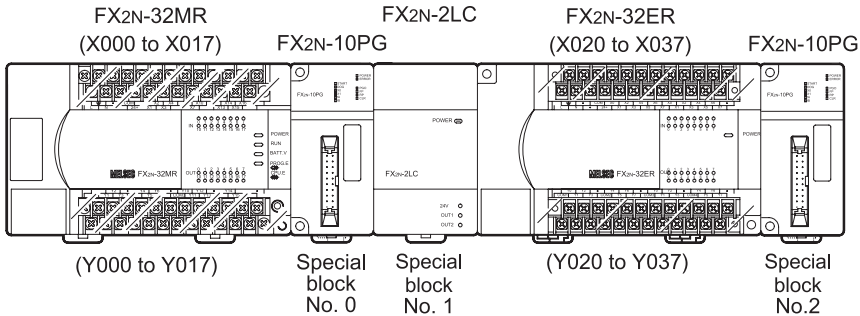

- Up to 8 FX2N-10PG can be connected to an FX2N/FX3U/FX3UC² series PLC.
Up to 4 units can be connected to an FX2NC series PLC.
- When connected to an FX2NC Series PLC, the FX2NC-CNV-IF is required.
When connected to an FX3UC Series PLC, the FX2NC-CNV-IF or FX3UC-1PS-5V is required.
- Optional cables FX0N-65EC or FX0N-30EC can be used to extend the distance from the host PLC.
Only one extension cable can be used per system.

*1 Because the special unit No.0 is assigned to the built-in CC-Link/LT master in the FX3UC-32MT-LT(-2), unit numbers assigned to special units begin with No.1.

*2 Up to 7 units can be connected to the FX3UC-32MT-LT(-2) PLC.

2.1 Applicable PLC

Series name	Applicable version
FX2N series	All versions (First release).
FX2NC series	All versions (First release).
FX3U series	All versions (First release).
FX3UC series	All versions (First release).

3. Installation



Caution

- 1) Do not lay signal cable near to high voltage power cable or house them in the same trunking duct. Effects of noise or surge induction may occur. Keep signal cables a safe distance of more than 100 mm (3.94") from these power cables.
- 2) Ground the shield wire or the shield of a shielded cable at one point on the PLC.
Do not, however, ground at the same point as high voltage lines.
- 3) Cut off all phases of power source before installing / removing or performing wiring work on the unit in order to avoid electric shock or damage of product.
- 4) Replace the provided terminal cover before supplying power and operating the unit after installation or wiring work, in order to avoid electric shock.

3.1 Mounting

The FX2N-10PG can be DIN rail direct wall mounted.

1) DIN rail mounting

- a) Align the upper side of the DIN rail mounting groove of the FX2N-10PG with a DIN rail *1 (①), and push it on the DIN rail (②). See Figure 3.1.
- b) When removing the FX2N-10PG from the DIN rail, the hook for DIN rail is pulled (③), and the FX2N-10PG is removed (④). See Figure 3.1.

*1 Uses DIN 46277 <35mm (1.38")>

Attach to DIN Rail and Remove from DIN Rai

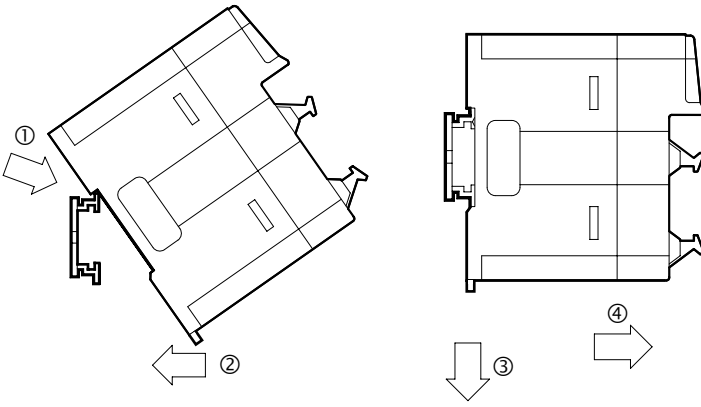

- 2) Direct mounting to back walls
 The FX_{2N}-10PG can be mounted with M4 screws, using the direct mounting holes.
 An interval space between each unit of 1-2 mm is necessary.

4. Specifications

4.1 General Specifications

General Specifications

Items	Specifications
Items other than the following	Same as general specification of the PLC main unit. (Refer to the PLC MANUAL)
Dielectric with stand voltage	AC 500V 1 minute (between each terminal and earth terminal)

4.2 Power Supply Specifications

Power Supply Specifications

Items	Specifications
Power supply	Input signal START,DOG,X0,X1: 24V DC +10% -10%. Consumption current 32mA or less. PG0, φA, φB: 3 to 5.5V DC. Consumption current 20mA or less. VIN: 5 to 24V DC. The consumption current when the power supply is used 5V DC is 100mA or less. The consumption current when the power supply is used 24V DC is 70mA or less. Power from external power supply. START,DOG,X0,X1 can connect service power supply of programmable controller main unit (24+ terminal)
	Internal control 5V DC consumption current 120mA from PLC main unit.
	Output signal FP, RP (Supply the power supply by the terminal of VIN. 5 to 24V DC): Have the current to 25mA or less. CLR: 5 to 24V DC have the consumption current to 20mA or less. Power from servo amplifier or external power supply

- Refer to the USER'S MANUAL for the performance specification and the I/O specification.

5. Diagnostics

5.1 Preliminary Checks

Check Wiring and Program of the PLC main unit when FX_{2N}-10PG does not operate normally.
 FX_{2N}-10PG will not operate normally if the FROM/TO instruction is executed when an abnormality occurs in the PLC main unit.
 Correspond according to the content when an abnormality occurs in the main unit (off POWER LED and blinking ERROR LED/Lit ERROR LED). (Refer to the HARDWARE MANUAL, PROGRAMMING MANUAL II for PLC)
 ERROR LED is lit when an operation error occurs in the PLC main unit while turned off. (The instruction where the operation error occurs is not executed.)
 Check the ON/OFF status of M8067 with external programming equipment, and correct any errors.

5.2 LED check

LED name	State display	Measures
POWER	OFF/ Blinking	<p>When the LED does not lit even if the power supply is supplied PLC.</p> <ul style="list-style-type: none"> Connect the extension cable between the PLC main unit and FX2N-10PG correctly. Supply power to the PLC main unit correctly. PLC service power supply capacity is exceeded. Remove wiring from the terminal of the service power supply.
START	OFF	<p>At START input ON.</p> <ul style="list-style-type: none"> Check the input wiring. An external power supply is necessary for the terminal START. (24V DC)
ERROR	Blinking	<ul style="list-style-type: none"> Error occurs in FX2N-10PG. Do measures corresponding to the content after checking the content of buffer memory (BFM#37). Refer to Specific manual name for details of BFM#37.
	Lit	<ul style="list-style-type: none"> Please contact a service representative.
FP	OFF	<p>When output forward pulses and reverse pulses.</p> <ul style="list-style-type: none"> Dependent on PLC program, start each drive or check.
RP	OFF	<ul style="list-style-type: none"> Do not output the pulse when there are stop, forward limit, and reversal limit instruction.
CLR	OFF	<p>When Home position return is completed.</p> <ul style="list-style-type: none"> Home position return drive, the data set type Home position return, and the compulsion output of the CLR signal must be executed by programming the PLC main unit or check.
	Lit	<p>When a clear signal is not input with the servo amplifier.</p> <ul style="list-style-type: none"> Check the output wiring. An external power supply is necessary for the terminal CLR output (5 to 24V DC).
DOG	OFF	<p>At DOG input ON.</p> <ul style="list-style-type: none"> Check the input wiring. An external power supply is necessary for the terminal DOG. (24V DC).
PG0	OFF	<p>At PG0 input ON.</p> <ul style="list-style-type: none"> Check the input wiring. When NPN/PNP opening collector transistor is used, an external power supply is necessary for the terminal PG0. (5V DC).
ϕA	OFF	<p>At ϕA, ϕB input ON.</p> <ul style="list-style-type: none"> Check the input wiring. When manual pulse generator of opening collector output type is used, an external power supply is necessary for the terminals ϕA, ϕB (5V DC).
ϕB	OFF	
X0,X1	OFF	<p>At X0,X1 input ON.</p> <ul style="list-style-type: none"> Check the input wiring. An external power supply is necessary for the terminal X0,X1 (24V DC).

This manual confers no industrial property rights or any rights of any other kind, nor does it confer any patent licenses. Mitsubishi Electric Corporation cannot be held responsible for any problems involving industrial property rights which may occur as a result of using the contents noted in this manual.

Manual number : JY992D91901

Manual revision : D

Date : April 2015

MITSUBISHI ELECTRIC CORPORATION

HEAD OFFICE: TOKYO BUILDING, 2-7-3 MARUNOUCHI, CHIYODA-KU, TOKYO 100-8310, JAPAN



FX_{2N} PULSE GENERATOR BLOCK INSTALLATION MANUAL

JY992D91901D

This manual contains text, diagrams and explanations which will guide the reader in the correct installation, safe use and operation of the FX_{2N}-10PG PULSE GENERATOR BLOCK and should be read and understood before attempting to install or use the unit. Further information can be found in the manuals listed under further information. Specifications are subject to change without notice

Guidelines for the Safety of the User and Protection of FX_{2N}-10PG PULSE GENERATOR BLOCK

This manual has been written to be used by trained and competent personnel. The definition of such a person or persons is as follows:

- a) Any engineer using the product associated with this manual, should be of a competent nature, trained and qualified to the local and national standards. These engineers should be fully aware of all aspects of safety with regards to automated equipment.
- b) Any commissioning or service engineer must be of a competent nature, trained and qualified to the local and national standards.
- c) All operators of the completed equipment should be trained to use that product in a safe and coordinated manner in compliance to established safety practices.

Note: The term 'completed equipment' refers to a third party constructed device which contains or uses the product associated with this manual.

Note's on the Symbols Used in this Manual

At various times through out this manual certain symbols will be used to highlight points of information which are intended to ensure the users personal safety and protect the integrity of equipment.

- 1) Indicates that the identified danger **WILL** cause physical and property damage.
- 2) Indicates that the identified danger could **POSSIBLY** cause physical and property damage.

- Under no circumstances will Mitsubishi Electric be liable responsible for any consequential damage that may arise as a result of the installation or use of this equipment.
- All examples and diagrams shown in this manual are intended only as an aid to understanding the text, not to guarantee operation. Mitsubishi Electric will accept no responsibility for actual use of the product based on these illustrative examples.
- Owing to the very great variety in possible application of this equipment, you must satisfy yourself as to its suitability for your specific application.

Further Information Manual Lists

Manual name	Manual No.	Description
FX _{2N} -10PG USER'S MANUAL	JY992D93401	Describes specifications, wiring, installation, handling, etc. of FX _{2N} -10PG.
FX _{2N} HARDWARE MANUAL	JY992D66301	Describes contents related to hardware of FX _{2N} series PLC such as specifications, wiring and installation.
FX _{3U} Series User's Manual - Hardware Edition	JY997D16501	Describes the specification, wiring and installation of FX _{3U} series PLC.
FX _{2NC} HARDWARE MANUAL	JY992D76401	Describes contents related to hardware of FX _{2NC} series PLC such as specifications, wiring and installation.
FX _{3UC} Series User's Manual - Hardware Edition	JY997D28701	Describes the specification, wiring and installation of FX _{3UC} series PLC.
FX SERIES PROGRAMMING MANUAL II	JY992D88101	Describes instructions of FX _{1S} /FX _{1N} /FX _{2N} /FX _{2NC} series PLC
FX _{3S} /FX _{3G} /FX _{3GC} /FX _{3U} /FX _{3UC} Series Programming Manual - Basic & Applied Instruction Edition	JY997D16601	This manual explains the installations of FX _{3S} /FX _{3G} /FX _{3GC} /FX _{3U} /FX _{3UC} series PLC.

1. Introduction

The FX_{2N}-10PG pulse generator block (Hereafter referred to as "FX_{2N}-10PG" or "pulse generator block") outputs pulses of 1MHz or less. It is a special function block to drive amplifiers for servo motors or stepper motors. It is connected to an FX_{2N}/FX_{2NC}/FX_{3U}/FX_{3UC} series Programmable controller (Hereafter referred to as "PLC") and used.

1.1 Features of the FX_{2N}-10PG

- 1) Positioning control with a stepper motor or servo motor.
(1 FX_{2N}-10PG can control 1 positioning axis.)
- 2) Can be connected to an FX_{2N}/FX_{2NC}/FX_{3U}/FX_{3UC} series PLC.
Data is read/written using FROM/TO instructions.
- 3) Pulses at up to 1MHz can be output.

1.2 External Dimensions and Each Part Name

Dimensions: mm (inches)
MASS (Weight): Approx. 0.2kg (0.44 lbs)
Accessory: Special block No. label

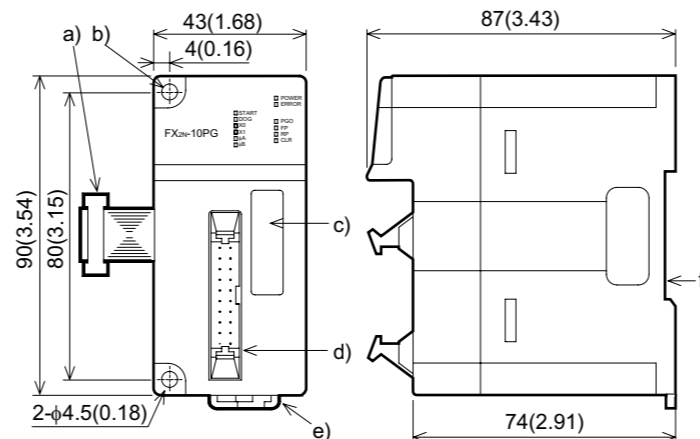

- a) Extension cable and connector
- b) Mounting hole 2-φ4.5(0.18inch)
- c) Extension port
- d) I/O port
- e) DIN rail clip
- f) Attachment groove for 35mm(1.38inch) wide DIN rail

1.3 LED display

LED name	State	Content of display
POWER	OFF	No 5V DC power from PLC main unit by way of the extension cable.
	Lit	5V DC is fed from the PLC main unit by way of the extension cable.
START	OFF	START input OFF.
	Lit	START input ON.
ERROR	OFF	Normal operation.
	Blinking	Error has occurred.
	Lit	CPU error
FP	OFF	Forward pulse or pulses not output.
	Blinking	Forward pulse or pulses output.
RP	OFF	Reverse pulse or direction command not output.
	Blinking or lit	Reverse pulse or direction command output.
CLR	OFF	CLR signal idle.
	Lit	CLR signal output (It completes Home position return).
DOG	OFF	DOG input OFF.
	Lit	DOG input ON.
PG0	OFF	Zero point signal input OFF.
	Lit	Zero point signal input ON.
φA	OFF	A phase input of manual pulse generator OFF.
	Blinking	A phase input of manual pulse generator ON.
φB	OFF	B phase input of manual pulse generator OFF.
	Blinking	B phase input of manual pulse generator ON.
X0,X1	OFF	Interrupt input OFF.
	Lit	Interrupt input ON.

1.4 Array and allocation of pin

I/O port

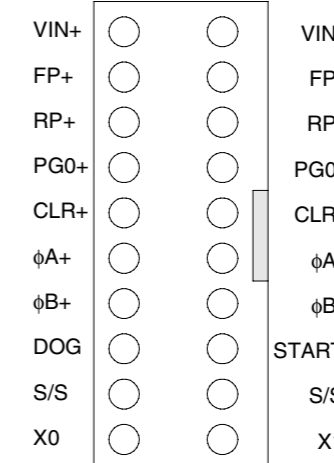

Terminal name	Content
VIN+	Power supply input terminal for pulse output (5 to 24V DC)
FP+	<ul style="list-style-type: none"> • Forward/reversal mode Forward pulse output terminal • Pulse/direction mode Pulse output terminal
RP+	<ul style="list-style-type: none"> • Forward/reversal mode Reversal pulse output terminal • Pulse/direction mode Direction output terminal
PG0+	Zero point signal input terminal
CLR+	Output terminal to clear collecting deflection counter pulse of servo amplifier
φA+	A phase input terminal of manual pulse generator
φB+	B phase input terminal of manual pulse generator
DOG	DOG input terminal
S/S	Power supply input terminal (START,DOG,X0,X1) (24V DC) Pins (S/S) are short-circuited internally
X0	Interruption input terminal
VIN-	Common terminal for VIN+
FP-	Common terminal for FP+
RP-	Common terminal for RP+
PG0-	Common terminal for PG0+
CLR-	Common terminal for CLR+
φA-	Common terminal of A phase input for manual pulse generator
φB-	Common terminal of B phase input for manual pulse generator
START	START input terminal
X1	Interruption input terminal

2. System configuration

The FX2N-10PG connects on the right side of a PLC main unit or extension unit/block (including special function blocks).

FX2N-10PG connects by extension cable from the PLC main unit.

(It is not possible to use the FX2N-10PG as a stand alone unit)

FX2N-10PG is a special function block. A special function unit number 0-7 is automatically assigned from the PLC corresponding to its location on the communication.*1

(Specified by FROM/TO instruction)

The FX2N-10PG occupies eight points of I/O.

Refer to the hardware manual of the connected main unit

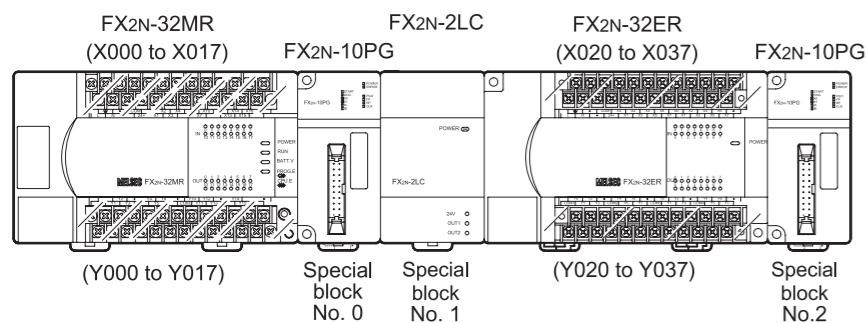

- Up to 8 FX2N-10PG can be connected to an FX2N/FX3U/FX3UC² series PLC.
Up to 4 units can be connected to an FX2NC series PLC.

- When connected to an FX2NC Series PLC, the FX2NC-CNV-IF is required.
When connected to an FX3UC Series PLC, the FX2NC-CNV-IF or FX3UC-1PS-5V is required.

- Optional cables FX0N-65EC or FX0N-30EC can be used to extend the distance from the host PLC.
Only one extension cable can be used per system.

*1 Because the special unit No.0 is assigned to the built-in CC-Link/LT master in the FX3UC-32MT-LT(-2), unit numbers assigned to special units begin with No.1.

*2 Up to 7 units can be connected to the FX3UC-32MT-LT(-2) PLC.

2.1 Applicable PLC

Series name	Applicable version
FX2N series	All versions (First release).
FX2NC series	All versions (First release).
FX3U series	All versions (First release).
FX3UC series	All versions (First release).

3. Installation

Caution

- Do not lay signal cable near to high voltage power cable or house them in the same trunking duct. Effects of noise or surge induction may occur. Keep signal cables a safe distance of more than 100 mm (3.94") from these power cables.
- Ground the shield wire or the shield of a shielded cable at one point on the PLC.
Do not, however, ground at the same point as high voltage lines.
- Cut off all phases of power source before installing / removing or performing wiring work on the unit in order to avoid electric shock or damage of product.
- Replace the provided terminal cover before supplying power and operating the unit after installation or wiring work, in order to avoid electric shock.

3.1 Mounting

The FX2N-10PG can be DIN rail direct wall mounted.

- DIN rail mounting
 - Align the upper side of the DIN rail mounting groove of the FX2N-10PG with a DIN rail *1 (①), and push it on the DIN rail (②). See Figure 3.1.
 - When removing the FX2N-10PG from the DIN rail, the hook for DIN rail is pulled (③), and the FX2N-10PG is removed (④). See Figure 3.1.

*1 Uses DIN 46277 <35mm (1.38")>

Attach to DIN Rail and Remove from DIN Rai

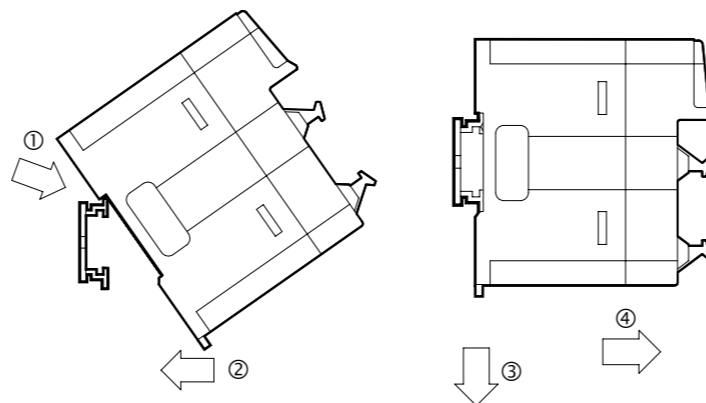

- Direct mounting to back walls
The FX2N-10PG can be mounted with M4 screws, using the direct mounting holes.
An interval space between each unit of 1-2 mm is necessary.

4. Specifications

4.1 General Specifications

General Specifications

Items	Specifications
Items other than the following	Same as general specification of the PLC main unit. (Refer to the PLC MANUAL)
Dielectric with stand voltage	AC 500V 1 minute (between each terminal and earth terminal)

4.2 Power Supply Specifications

Power Supply Specifications

Items	Specifications
Power supply	Input signal START, DOG, X0, X1: 24V DC +10% -10%. Consumption current 32mA or less. PG0, φA, φB: 3 to 5.5V DC. Consumption current 20mA or less. VIN: 5 to 24V DC. The consumption current when the power supply is used 5V DC is 100mA or less. The consumption current when the power supply is used 24V DC is 70mA or less. Power from external power supply. START, DOG, X0, X1 can connect service power supply of programmable controller main unit (24+ terminal)
	Internal control 5V DC consumption current 120mA from PLC main unit.
	Output signal FP, RP (Supply the power supply by the terminal of VIN. 5 to 24V DC): Have the current to 25mA or less. CLR: 5 to 24V DC have the consumption current to 20mA or less. Power from servo amplifier or external power supply

- Refer to the USER'S MANUAL for the performance specification and the I/O specification.

5. Diagnostics

5.1 Preliminary Checks

Check Wiring and Program of the PLC main unit when FX2N-10PG does not operate normally.
FX2N-10PG will not operate normally if the FROM/TO instruction is executed when an abnormality occurs in the PLC main unit.

Correspond according to the content when an abnormality occurs in the main unit (off POWER LED and blinking ERROR LED/Lit ERROR LED). (Refer to the HARDWARE MANUAL, PROGRAMMING MANUAL II for PLC)

ERROR LED is lit when an operation error occurs in the PLC main unit while turned off. (The instruction where the operation error occurs is not executed.)

Check the ON/OFF status of M8067 with external programming equipment, and correct any errors.

5.2 LED check

LED name	State display	Measures
POWER	OFF/ Blinking	When the LED does not lit even if the power supply is supplied PLC. <ul style="list-style-type: none"> Connect the extension cable between the PLC main unit and FX2N-10PG correctly. Supply power to the PLC main unit correctly. PLC service power supply capacity is exceeded. Remove wiring from the terminal of the service power supply.
	START	At START input ON. <ul style="list-style-type: none"> Check the input wiring. An external power supply is necessary for the terminal START. (24V DC)
ERROR	Blinking	Error occurs in FX2N-10PG. Do measures corresponding to the content after checking the content of buffer memory (BFM#37). Refer to Specific manual name for details of BFM#37.
	Lit	Please contact a service representative.
FP	OFF	When output forward pulses and reverse pulses. <ul style="list-style-type: none"> Dependent on PLC program, start each drive or check.
RP	OFF	Do not output the pulse when there are stop, forward limit, and reversal limit instruction.
CLR	OFF	When Home position return is completed. <ul style="list-style-type: none"> Home position return drive, the data set type Home position return, and the compulsion output of the CLR signal must be executed by programming the PLC main unit or check.
	Lit	When a clear signal is not input with the servo amplifier. <ul style="list-style-type: none"> Check the output wiring. An external power supply is necessary for the terminal CLR output (5 to 24V DC).
DOG	OFF	At DOG input ON. <ul style="list-style-type: none"> Check the input wiring. An external power supply is necessary for the terminal DOG. (24V DC).
PG0	OFF	At PG0 input ON. <ul style="list-style-type: none"> Check the input wiring. When NPN/PNP opening collector transistor is used, an external power supply is necessary for the terminal PG0. (5V DC).
φA	OFF	At φA, φB input ON. <ul style="list-style-type: none"> Check the input wiring. When manual pulse generator of opening collector output type is used, an external power supply is necessary for the terminals φA, φB (5V DC).
φB	OFF	
X0, X1	OFF	At X0, X1 input ON. <ul style="list-style-type: none"> Check the input wiring. An external power supply is necessary for the terminal X0, X1 (24V DC).

This manual confers no industrial property rights or any rights of any other kind, nor does it confer any patent licenses. Mitsubishi Electric Corporation cannot be held responsible for any problems involving industrial property rights which may occur as a result of using the contents noted in this manual.

Manual number : JY992D91901

Manual revision : D

Date : April 2015

MITSUBISHI ELECTRIC CORPORATION

HEAD OFFICE: TOKYO BUILDING, 2-7-3 MARUNOUCHI, CHIYODA-KU, TOKYO 100-8310, JAPAN

JY992D91901D

Effective April 2015
Specifications are subject to
change without notice