

MELSEC FX series

Programmable Controllers



User's Manual
(Analog Control Edition)



FX3G/FX3U/FX3UC

Safety Precautions

(Read these precautions before use.)

Before installation, operation, maintenance or inspection of this product, thoroughly read through and understand this manual and all of the associated manuals. Also, take care to handle the module properly and safely.

This manual classifies the safety precautions into two categories:  **DANGER** and  **CAUTION**.

 DANGER	Indicates that incorrect handling may cause hazardous conditions, resulting in death or severe injury.
 CAUTION	Indicates that incorrect handling may cause hazardous conditions, resulting in medium or slight personal injury or physical damage.

Depending on the circumstances, procedures indicated by  **CAUTION** may also cause severe injury. It is important to follow all precautions for personal safety.

Store this manual in a safe place so that it can be taken out and read whenever necessary. Always forward it to the end user.

1. DESIGN PRECAUTIONS

 DANGER
<ul style="list-style-type: none">• Make sure to have the following safety circuits outside of the PLC to ensure safe system operation even during external power supply problems or PLC failure. Otherwise, malfunctions may cause serious accidents.<ol style="list-style-type: none">1) Most importantly, have the following: an emergency stop circuit, a protection circuit, an interlock circuit for opposite movements (such as normal vs. reverse rotation), and an interlock circuit (to prevent damage to the equipment at the upper and lower positioning limits).2) Note that when the PLC CPU detects an error, such as a watchdog timer error, during self-diagnosis, all outputs are turned off. Also, when an error that cannot be detected by the PLC CPU occurs in an input/output control block, output control may be disabled. External circuits and mechanisms should be designed to ensure safe machinery operation in such a case.3) Note that the output current of the service power supply for sensors varies depending on the model and the absence/presence of extension blocks. If an overload occurs, the voltage automatically drops, inputs in the PLC are disabled, and all outputs are turned off. External circuits and mechanisms should be designed to ensure safe machinery operation in such a case.4) Note that when an error occurs in a relay, triac or transistor output device, the output could be held either on or off. For output signals that may lead to serious accidents, external circuits and mechanisms should be designed to ensure safe machinery operation in such a case.

 CAUTION
<ul style="list-style-type: none">• Do not bundle the control line together with or lay it close to the main circuit or power line. As a guideline, lay the control line at least 100mm(3.94") or more away from the main circuit or power line. Noise may cause malfunctions.• Make sure to ground the shield wire or shield of the shielded cable connected to an analog input expansion board, special adapter, or special function block at one point on the PLC. However, do not use common grounding with heavy electrical systems. Noise may cause malfunctions.• Make sure to ground the shield wire or shield of the shielded cable connected to an analog output expansion board, special adapter, or special function block at one point on the analog device side. However, do not use common grounding with heavy electrical systems. Noise may cause malfunctions.• Install module so that excessive force will not be applied to the power connectors or terminal blocks. Failure to do so may result in wire damage/breakage or PLC failure.

Safety Precautions

(Read these precautions before use.)

2. WIRING PRECAUTIONS

DANGER

- Make sure to cut off all phases of the power supply externally before attempting wiring work. Failure to do so may cause electric shock or damages to the product.

CAUTION

- Connect the DC power supply wiring to the dedicated terminals described in this manual. If an AC power supply is connected to a DC input/output terminal or DC power supply terminal, the PLC will be burnt out.
- Do not wire vacant terminals externally. Doing so may damage the product.
- Perform class D grounding (grounding resistance: 100Ω or less) to the grounding terminal on the main unit. Do not use common grounding with heavy electrical systems.
- When drilling screw holes or wiring, make sure cutting or wire debris does not enter the ventilation slits. Failure to do so may cause fire, equipment failures or malfunctions.
- Make sure to observe the following precautions in order to prevent malfunctions under the influence of noise:
 - Do not bundle the power line or twisted shielded cable together with or lay it close to the main circuit, high-voltage line, or load line. Otherwise, noise disturbance and/or surge induction are likely to take place. As a guideline, lay the control line at least 100mm (3.94") or more away from the main circuit, high-voltage line, or load line.
 - Ground the shield of the analog input/output cable at one point on the signal receiving side. However, do not use common grounding with heavy electrical systems.
- Make sure to properly wire to the European terminal board in accordance with the following precautions. Failure to do so may cause electric shock, equipment failures, a short-circuit, wire breakage, malfunctions, or damage to the product.
 - The disposal size of the cable end should follow the dimensions described in the manual.
 - Tightening torque should follow the specifications in the manual.
 - Twist the end of strand wire and make sure there are no loose wires.
 - Do not solder-plate the electric wire ends.
 - Do not connect more than the specified number of wires or electric wires of unspecified size.
 - Affix the electric wires so that neither the terminal block nor the connected parts are directly stressed.
- Make sure to properly wire the terminal block in accordance with the following precautions. Failure to do so may cause electric shock, equipment failures, a short-circuit, wire breakage, malfunctions, or damage to the product.
 - The disposal size of the cable end should follow the dimensions described in the manual.
 - Tightening torque should follow the specifications in the manual.

Safety Precautions

(Read these precautions before use.)

3. STARTUP AND MAINTENANCE PRECAUTIONS

DANGER

- Do not touch any terminal while the PLC's power is on.
Doing so may cause electrical shock or malfunctions.
- Before cleaning or retightening terminals, cut off all phases of the power supply externally.
Failure to do so may cause electric shock.
- Before modifying or disrupting the program in operation or running the PLC, carefully read through this manual and the associated manuals and ensure the safety of the operation.
An operation error may damage the machinery or cause accidents.
- Do not change the program in the PLC from two or more peripheral equipment devices at the same time. (i.e. from a programming tool and a GOT)
Doing so may cause destruction or malfunction of the PLC program.

CAUTION

- Do not disassemble or modify the PLC.
Doing so may cause fire, equipment failures, or malfunctions.
For repair, contact your local Mitsubishi Electric distributor.
- Turn off the power to the PLC before connecting or disconnecting any extension cable.
Failure to do so may cause equipment failures or malfunctions.
- Turn off the power to the PLC before attaching or detaching the peripheral devices, expansion boards, special adapters, and extension blocks.
Failure to do so may cause equipment failures or malfunctions.

Safety Precautions

(Read these precautions before use.)

MEMO

FX3G/FX3U/FX3UC Series Programmable Controllers

User's Manual [Analog Control Edition]

Manual number	JY997D16701
Manual revision	H
Date	8/2010

Foreword

This manual describes the "analog" function of the MELSEC-F FX Series programmable controllers and should be read and understood before attempting to install or use the unit.

Store this manual in a safe place so that you can take it out and read it whenever necessary. Always forward it to the end user.

This manual confers no industrial property rights or any rights of any other kind, nor does it confer any patent licenses. Mitsubishi Electric Corporation cannot be held responsible for any problems involving industrial property rights which may occur as a result of using the contents noted in this manual.

© 2005 MITSUBISHI ELECTRIC CORPORATION

Outline Precautions

- This manual provides information for the use of the FX3U Series Programmable Controllers. The manual has been written to be used by trained and competent personnel. The definition of such a person or persons is as follows;
 - 1) Any engineer who is responsible for the planning, design and construction of automatic equipment using the product associated with this manual should be of a competent nature, trained and qualified to the local and national standards required to fulfill that role. These engineers should be fully aware of all aspects of safety with regards to automated equipment.
 - 2) Any commissioning or service engineer must be of a competent nature, trained and qualified to the local and national standards required to fulfill that job. These engineers should also be trained in the use and maintenance of the completed product. This includes being completely familiar with all associated documentation for the said product. All maintenance should be carried out in accordance with established safety practices.
 - 3) All operators of the completed equipment should be trained to use that product in a safe and coordinated manner in compliance to established safety practices. The operators should also be familiar with documentation which is connected with the actual operation of the completed equipment.

Note: The term 'completed equipment' refers to a third party constructed device which contains or uses the product associated with this manual

- This product has been manufactured as a general-purpose part for general industries, and has not been designed or manufactured to be incorporated in a device or system used in purposes related to human life.
- Before using the product for special purposes such as nuclear power, electric power, aerospace, medicine or passenger movement vehicles, consult with Mitsubishi Electric.
- This product has been manufactured under strict quality control. However when installing the product where major accidents or losses could occur if the product fails, install appropriate backup or failsafe functions in the system.
- When combining this product with other products, please confirm the standard and the code, or regulations with which the user should follow. Moreover, please confirm the compatibility of this product to the system, machine, and apparatus with which a user is using.
- If in doubt at any stage during the installation of the product, always consult a professional electrical engineer who is qualified and trained to the local and national standards. If in doubt about the operation or use, please consult the nearest Mitsubishi Electric distributor.
- Since the examples indicated by this manual, technical bulletin, catalog, etc. are used as a reference, please use it after confirming the function and safety of the equipment and system. Mitsubishi Electric will accept no responsibility for actual use of the product based on these illustrative examples.
- This manual content, specification etc. may be changed without a notice for improvement.
- The information in this manual has been carefully checked and is believed to be accurate; however, if you have noticed a doubtful point, a doubtful error, etc., please contact the nearest Mitsubishi Electric distributor.

Registration

- The company name and the product name to be described in this manual are the registered trademarks or trademarks of each company.

Table of Contents

SAFETY PRECAUTIONS (1)

Common Items

1. Introduction	A-1
1.1 Outline and Features of Analog Control.....	A-1
1.1.1 Analog input control.....	A-2
1.1.2 Analog output control.....	A-3
1.1.3 Temperature sensor input control.....	A-4
2. Description of Analog Products	A-5
2.1 Types of Analog Products.....	A-5
2.1.1 Expansion board.....	A-5
2.1.2 Special adapter.....	A-6
2.1.3 Special function block.....	A-8
2.2 List of Analog Product Models.....	A-9
2.2.1 Expansion board.....	A-9
2.2.2 Special adapter.....	A-9
2.2.3 Special function block.....	A-10
3. System Configuration Drawings of Analog Products	A-13
3.1 FX3U Series PLC.....	A-13
3.1.1 Connection of special adapters.....	A-13
3.1.2 Connection of special function blocks.....	A-14
3.2 FX3UC Series PLC.....	A-15
3.2.1 Connection of special adapters.....	A-15
3.2.2 Connection of special function blocks.....	A-17
3.3 FX3G Series PLC.....	A-19
3.3.1 Connection of expansion boards, special adapters.....	A-19
3.3.2 Connection of special function blocks.....	A-21
4. Comparison of Performance Specifications	A-22
4.1 Analog Input.....	A-22
4.1.1 FX3U-4AD-ADP.....	A-22
4.1.2 FX2N-2AD.....	A-23
4.1.3 FX3U-4AD.....	A-24
4.1.4 FX2N-4AD.....	A-25
4.1.5 FX3UC-4AD.....	A-26
4.1.6 FX2NC-4AD.....	A-27
4.1.7 FX2N-8AD.....	A-28
4.1.8 FX3G-2AD-BD.....	A-29
4.2 Analog Output.....	A-30
4.2.1 FX3U-4DA-ADP.....	A-30
4.2.2 FX2N-2DA.....	A-31
4.2.3 FX3U-4DA.....	A-32
4.2.4 FX2N-4DA.....	A-33
4.2.5 FX2NC-4DA.....	A-34
4.2.6 FX3G-1DA-BD.....	A-35
4.3 Mixed Analog Input/Output.....	A-36
4.3.1 FX3U-3A-ADP.....	A-36
4.3.2 FX2N-5A.....	A-37
4.3.3 FX0N-3A.....	A-39

4.4 Temperature Sensor Input	A-40
4.4.1 FX3U-4AD-PT-ADP	A-40
4.4.2 FX3U-4AD-PTW-ADP	A-41
4.4.3 FX3U-4AD-PNK-ADP	A-42
4.4.4 FX3U-4AD-TC-ADP	A-43
4.4.5 FX2N-4AD-PT	A-44
4.4.6 FX2N-4AD-TC	A-45
4.4.7 FX2N-8AD	A-46
4.4.8 FX2N-2LC	A-47
4.4.9 FX3U-4LC	A-48

5. Version Number	A-49
--------------------------	-------------

5.1 PLC Main Unit	A-49
5.1.1 Manufacturer's serial number check method	A-49
5.1.2 Version check	A-50
5.2 Special adapter	A-51
5.2.1 Manufacturer's serial number check method	A-51

6. Manual Introduction (Types, Contents, and Obtainment)	A-52
---	-------------

6.1 How to Use the Manuals	A-52
6.2 Description of Related Manuals	A-53
6.2.1 Analog control manuals	A-53
6.2.2 Manuals related to the FX3G/FX3U/FX3UC Series PLC main unit	A-53
6.2.3 Manuals of analog units	A-55

7. Generic Names and Abbreviations in This Manual	A-57
--	-------------

FX_{3U}-4AD (4-channel Analog Input)

FX_{3UC}-4AD (4-channel Analog Input)

1. Outline	B-3
1.1 Outline of Functions	B-3
1.2 Setup Procedure Before Starting Operation	B-4
1.3 Connectable PLC and Version Numbers	B-5
1.4 Compatible Programming Tool Version Number	B-5
2. Specifications	B-6
2.1 Generic Specifications	B-6
2.2 Power Supply Specifications	B-7
2.3 Performance Specifications	B-7
2.4 Input Mode (Characteristics) BFM #0	B-8
3. Wiring	B-10
3.1 Terminal Layout	B-11
3.2 Cable and Terminal Tightening Torque.....	B-12
3.2.1 Power cable (FX _{3UC} -4AD)	B-12
3.2.2 Cable (FX _{3U} -4AD).....	B-12
3.2.3 Cable (FX _{3UC} -4AD).....	B-13
3.3 Examples of Power Supply Circuit.....	B-14
3.3.1 FX _{3U} -4AD.....	B-14
3.3.2 FX _{3UC} -4AD	B-15
3.3.3 Cautions regarding connection of power cables.....	B-15
3.4 Analog Input Line	B-16
3.4.1 FX _{3U} -4AD.....	B-16
3.4.2 FX _{3UC} -4AD	B-17
3.5 Grounding	B-17
4. Analog Input	B-18
4.1 Analog Input Procedures.....	B-18
5. Buffer Memory (BFM)	B-20
5.1 Assignment of Unit Numbers and Outline of Buffer Memory	B-20
5.2 Buffer Memory Reading/Writing Method	B-22
5.2.1 Buffer memory direct specification (FX _{3U} , FX _{3UC} PLC only).....	B-22
5.2.2 FROM/TO instruction (FX _{3G} , FX _{3U} , FX _{3UC} PLC).....	B-22
5.3 Buffer Memory List (BFM)	B-23
5.4 Buffer Memory Details.....	B-27
5.4.1 BFM #0: Input mode specification	B-27
5.4.2 BFM #2 to #5: Averaging time	B-28
5.4.3 BFM #6 to #9: Digital filter setting.....	B-29
5.4.4 BFM #10 to #13: Channel data.....	B-30
5.4.5 BFM #19: Data change disable	B-31
5.4.6 BFM #20: Initialization function (resetting to factory default status)	B-31
5.4.7 BFM #21: Input characteristics writing.....	B-31
5.4.8 BFM #22: Convenient function setting.....	B-32
5.4.9 BFM #26: Upper/lower limit error status	B-34
5.4.10 BFM #27: Abrupt change detection status	B-35

5.4.11	BFM #28: Over-scale status	B-36
5.4.12	BFM #29: Error status	B-37
5.4.13	BFM #30: Model code	B-38
5.4.14	BFM #41 to #44: Offset data / BFM #51 to #54: Gain data	B-38
5.4.15	BFM #61 to #64: Addition data	B-39
5.4.16	BFM #71 to #74: Lower limit error setting / BFM #81 to #84: Upper limit error setting	B-40
5.4.17	BFM #91 to #94: Abrupt change detection value setting	B-41
5.4.18	BFM #99: Clearance of upper/lower limit error data and abrupt change detection data	B-42
5.4.19	BFM #101 to #104: Minimum peak value / BFM #111 to #114: Maximum peak value	B-42
5.4.20	BFM #109: Minimum peak value resetting / BFM #119: Maximum peak value resetting	B-43
5.4.21	BFM #125: Peak value automatic transfer to first data register specification	B-43
5.4.22	BFM #126: Upper/lower error status data automatic transfer-to data register specification	B-44
5.4.23	BFM #127: Abrupt change detection status data automatic transfer-to data register specification	B-45
5.4.24	BFM #128: Over-scale status data automatic transfer-to data register specification	B-46
5.4.25	BFM #129: Error status data automatic transfer-to data register specification	B-46
5.4.26	BFM #197: Selection of cyclic data update function (function for data history)	B-47
5.4.27	BFM #198: Data history sampling time setting	B-47
5.4.28	BFM #199: Data history resetting/stoppage	B-48
5.4.29	BFM #200 to #6999: Data history	B-49

6. Changing Input Characteristics **B-50**

6.1	Procedure for Changing Input Characteristics	B-50
-----	--	------

7. Examples of Practical Programs **B-53**

7.1	Program That Uses Averaging Time	B-53
7.2	Program That Uses Convenient Functions	B-55
7.3	Program That Uses Data History Function	B-58
7.4	Initialization Program for 4AD (Factory Default)	B-61

8. Troubleshooting **B-62**

8.1	PLC Version Number Check	B-62
8.2	Wiring Check	B-62
8.3	Program Check	B-62
8.4	Error Status Check	B-63
8.5	4AD Initialization and Test Program	B-64

FX_{3U}-4AD-ADP (4-channel analog Input)

1. Outline	C-3
1.1 Outline of Functions	C-3
1.2 Setup Procedure Before Starting Operation	C-4
1.3 Connectable PLCs and Version Number	C-5
1.4 Compatible Programming Tool Version Number	C-5
2. Specifications	C-6
2.1 Generic Specifications	C-6
2.2 Power Supply Specifications	C-7
2.3 Performance Specifications	C-7
2.4 A/D Conversion Time	C-8
2.4.1 When connected to a FX3U, FX3UC PLC	C-8
2.4.2 When connected to a FX3G PLC	C-9
3. Wiring	C-10
3.1 Terminal Layout	C-11
3.2 Applicable Cables and Terminal Tightening Torque	C-12
3.3 Power Supply Line	C-13
3.3.1 To connect to the FX3G, FX3U Series PLC	C-13
3.3.2 To connect to the FX3UC Series PLC	C-13
3.4 Analog Input Line	C-14
3.5 Grounding	C-14
4. Programming	C-15
4.1 Loading of A/D Conversion Data	C-15
4.2 List of Special Devices	C-17
4.3 Switching of Input Mode	C-18
4.4 Input Data	C-19
4.5 Averaging Time	C-20
4.6 Error Status	C-21
4.7 Model Code	C-23
4.8 Basic Program Example	C-24
5. Changing of Input Characteristics	C-26
5.1 Example: Changing of Voltage Input Characteristics	C-26
6. Troubleshooting	C-29
6.1 PLC Version Number Check	C-29
6.2 Wiring Check	C-29
6.3 Special Device Check	C-30
6.4 Program Check	C-30
6.5 Error Status Check	C-31

FX_{3G}-2AD-BD (2-channel analog Input)

1. Outline	D-3
1.1 Outline of Functions	D-3
1.2 Setup Procedure Before Starting Operation	D-4
1.3 Connectable PLCs and Version Number	D-5
1.4 Compatible Programming Tool Version Number	D-5
2. Specifications	D-6
2.1 Generic Specifications	D-6
2.2 Performance Specifications	D-7
2.3 A/D Conversion Time	D-8
3. Wiring	D-9
3.1 Terminal Layout	D-10
3.2 Applicable Cables and Terminal Tightening Torque	D-11
3.3 Analog Input Line	D-12
3.4 Grounding	D-12
4. Programming	D-13
4.1 Loading of A/D Conversion Data	D-13
4.2 List of Special Devices	D-14
4.3 Switching of Input Mode	D-14
4.4 Input Data	D-15
4.5 Averaging Time	D-16
4.6 Error Status	D-17
4.7 Model Code	D-19
4.8 Basic Program Example	D-19
5. Changing of Input Characteristics	D-20
5.1 Example: Changing of Voltage Input Characteristics	D-20
6. Troubleshooting	D-21
6.1 PLC Version Number Check	D-21
6.2 Checking Installation	D-21
6.3 Wiring Check	D-21
6.4 Special Device Check	D-21
6.5 Program Check	D-22
6.6 Error Status Check	D-22

FX_{3U}-4DA (4-channel Analog Output)

1. Outline	E-3
1.1 Outline of Functions	E-3
1.2 Setup Procedure Before Starting Operation	E-4
1.3 Connectable PLCs and Version Numbers	E-5
1.4 Compatible Programming Tool Version Number	E-5
2. Specifications	E-6
2.1 Generic Specifications	E-6
2.2 Power Supply Specifications.....	E-7
2.3 Performance Specifications	E-7
2.4 Output Mode (Characteristics) BFM #0.....	E-8
3. Wiring	E-9
3.1 Terminal Layout	E-10
3.2 Cable and Terminal Tightening Torque.....	E-10
3.3 Wiring to Power Supply Terminals.....	E-11
3.3.1 Examples of Power Supply Circuit	E-11
3.3.2 Cautions regarding wiring to the power supply terminals.....	E-11
3.4 Analog Output Wiring.....	E-12
3.5 Grounding	E-12
4. Analog Output	E-13
4.1 Analog Output Procedures.....	E-13
5. Buffer Memory (BFM)	E-15
5.1 Assignment of Unit Numbers and Outline of Buffer Memory	E-15
5.2 Buffer Memory Reading/Writing Method.....	E-16
5.2.1 Buffer memory direct specification (FX3U, FX3UC PLC only).....	E-17
5.2.2 FROM/TO instruction (FX3G, FX3U, FX3UC PLC).....	E-17
5.3 Buffer Memory List (BFM).....	E-18
5.4 Buffer Memory Details.....	E-21
5.4.1 BFM #0: Output mode specification	E-21
5.4.2 BFM #1 to #4: Output data	E-22
5.4.3 BFM #5: Output setting upon PLC stop.....	E-22
5.4.4 BFM #6: Output status.....	E-23
5.4.5 BFM #9: Offset/gain setting value write command.....	E-24
5.4.6 BFM #10 to #13: Offset data/BFM #14 to #17: Gain data	E-25
5.4.7 BFM #19: Data change prohibition of setting change.....	E-26
5.4.8 BFM #20: Initialization function (resetting to factory default status)	E-27
5.4.9 BFM #28: Disconnection detection status (only in current output mode)	E-27
5.4.10 BFM #29: Error status	E-28
5.4.11 BFM #30: Model code	E-29
5.4.12 BFM #32 to #35: Data to be output upon PLC stop.....	E-29
5.4.13 BFM #38: Upper/lower limit function setting.....	E-30
5.4.14 BFM #39: Upper/lower limit function status	E-31
5.4.15 BFM #40: Clearance of upper/lower limit function status	E-31
5.4.16 BFM #41 to #44: Lower limit values of upper/lower limit function BFM #45 to #48: Upper limit values of upper/lower limit function.....	E-32

5.4.17 BFM #50: Setting of output corrective function by load resistance
 (only in voltage output mode)/BFM #51 to #54: Load resistance valuesE-33

5.4.18 BFM #60: Status automatic transfer function setting.....E-34

5.4.19 BFM #61: Error status data automatic transfer-to data register specification.....E-35

5.4.20 BFM #62: Upper/lower limit function status data automatic transfer-to data register
 specificationE-36

5.4.21 BFM #63: Specification of data register for automatic transfer at disconnection detectionE-37

5.4.22 BFM #80 to #3098: Table output functionE-37

6. Table Output Function **E-38**

6.1 Outline of Table Output FunctionE-38

6.2 Preparation of data table.....E-39

6.3 Procedures for transferring data table to buffer memoryE-44

6.4 Procedures for executing table output function.....E-48

6.5 Details of table output error.....E-50

6.6 Examples uses of table output functionE-52

7. Changing Output Characteristics **E-53**

7.1 Procedure for Changing Output CharacteristicsE-53

8. Examples of Practical Programs **E-56**

8.1 Example of Program for Analog Output Operation (Regular Operation).....E-56

8.2 Example of Program using Useful Functions.....E-57

8.3 Example of Program for Table Output Operation (Pattern Output Operation)E-60

8.4 Program to Initialize FX3U-4DA (Factory Default).....E-63

9. Troubleshooting **E-64**

9.1 PLC Version Number CheckE-64

9.2 Wiring Check.....E-64

9.3 Program CheckE-64

9.4 Error Status Check.....E-65

9.5 FX3U-4DA Initialization and Test Program.....E-66

FX_{3U}-4DA-ADP (4-channel analog Output)

1. Outline	F-3
1.1 Outline of Functions	F-3
1.2 Setup Procedure Before Starting Operation	F-4
1.3 Connectable PLCs and Version Numbers	F-5
1.4 Compatible Programming Tool Version Number	F-5
2. Specifications	F-6
2.1 Generic Specifications	F-6
2.2 Power Supply Specifications	F-7
2.3 Performance Specifications	F-7
2.4 D/A Conversion Time	F-8
2.4.1 When connected to a FX3U, FX3UC PLC	F-8
2.4.2 When connected to a FX3G PLC	F-9
3. Wiring	F-10
3.1 Terminal Layout	F-11
3.2 Applicable Cables and Terminal Tightening Torque	F-12
3.3 Power Supply Line	F-13
3.3.1 To connect to the FX3G, FX3U Series PLC	F-13
3.3.2 To connect to the FX3UC Series PLC	F-13
3.4 Analog Output Line	F-14
3.5 Grounding	F-14
4. Programming	F-15
4.1 Writing of D/A Conversion Data	F-15
4.2 List of Special Devices	F-17
4.3 Switching of Output Mode	F-18
4.4 Output Holding Function Cancellation Setting	F-19
4.5 Output Setting Data	F-20
4.6 Error Status	F-21
4.7 Model Code	F-23
4.8 Basic Program Example	F-23
5. Changing of Output Characteristics	F-24
5.1 Example: Changing of Voltage Output Characteristics	F-24
6. Troubleshooting	F-26
6.1 PLC Version Number Check	F-26
6.2 Wiring Check	F-26
6.3 Special Device Check	F-26
6.4 Program Check	F-27
6.5 Error Status Check	F-27

FX₃G-1DA-BD (1-channel analog Output)

1. Outline	G-3
1.1 Outline of Functions	G-3
1.2 Setup Procedure Before Starting Operation	G-4
1.3 Connectable PLCs and Version Numbers	G-5
1.4 Compatible Programming Tool Version Number	G-5
2. Specifications	G-6
2.1 Generic Specifications	G-6
2.2 Performance Specifications	G-7
2.3 D/A Conversion Time	G-8
3. Wiring	G-9
3.1 Terminal Layout	G-10
3.2 Applicable Cables and Terminal Tightening Torque	G-11
3.3 Analog Output Line	G-12
3.4 Grounding	G-12
4. Programming	G-13
4.1 Writing of D/A Conversion Data	G-13
4.2 List of Special Devices	G-14
4.3 Switching of Output Mode	G-14
4.4 Output Holding Function Cancellation Setting	G-15
4.5 Output Setting Data	G-15
4.6 Error Status	G-16
4.7 Model Code	G-16
4.8 Basic Program Example	G-17
5. Changing of Output Characteristics	G-18
5.1 Example: Changing of Voltage Output Characteristics	G-18
6. Troubleshooting	G-19
6.1 PLC Version Number Check	G-19
6.2 Checking installation	G-19
6.3 Wiring Check	G-19
6.4 Special Device Check	G-19
6.5 Program Check	G-20
6.6 Error Status Check	G-20

FX_{3U}-3A-ADP (2-channel analog Input, 1-channel analog output)

1. Outline	H-3
1.1 Outline of Functions	H-3
1.2 Setup Procedure Before Starting Operation	H-4
1.3 Connectable PLCs and Version Number	H-5
1.4 Compatible Programming Tool Version Number	H-5
2. Specifications	H-6
2.1 Generic Specifications	H-6
2.2 Power Supply Specifications	H-6
2.3 Performance Specifications	H-7
2.4 Conversion Time	H-8
2.4.1 When connected to a FX3U, FX3UC PLC	H-8
2.4.2 When connected to a FX3G PLC	H-9
3. Wiring	H-10
3.1 Terminal Layout	H-11
3.2 Applicable Cables and Terminal Tightening Torque	H-12
3.3 Power Supply Line	H-13
3.3.1 To connect to the FX3G, FX3U Series PLC	H-13
3.3.2 To connect to the FX3UC Series PLC	H-13
3.4 Analog Input / output Line	H-14
3.4.1 Analog Input Line	H-14
3.4.2 Analog Output Line	H-14
3.5 Grounding	H-15
4. Programming	H-16
4.1 Loading/Writing of Conversion Data	H-16
4.2 List of Special Devices	H-17
4.3 Switching of Input Mode	H-18
4.4 Switching of Output Mode	H-19
4.5 Output Holding Function Cancellation Setting	H-19
4.6 Setting whether or not a channel is used	H-20
4.7 Input Data	H-21
4.8 Output Setting Data	H-22
4.9 Averaging Time	H-23
4.10 Error Status	H-24
4.11 Model Code	H-26
4.12 Basic Program Example	H-27
5. Changing of Input/output Characteristics	H-29
5.1 Example: Changing of Voltage Input Characteristics	H-29
5.2 Example: Changing of Voltage Output Characteristics	H-32

6. Troubleshooting**H-34**

6.1 PLC Version Number Check	H-34
6.2 Wiring Check.....	H-34
6.3 Special Device Check	H-34
6.4 Program Check	H-35
6.5 Error Status Check.....	H-35

FX_{3U}-4AD-PT-ADP

(4-channel Platinum Resistance Thermometer Data Input)

1. Outline	I-3
1.1 Outline of Functions	I-3
1.2 Setup Procedure Before Starting Operation	I-4
1.3 Connectable PLC and Its Version Number	I-5
1.4 Compatible Programming Tool Version Number	I-5
2. Specifications	I-6
2.1 Generic Specifications	I-6
2.2 Power Supply Specifications	I-7
2.3 Performance Specifications	I-7
2.4 A/D Conversion Time	I-8
2.4.1 When connected to a FX3U, FX3UC PLC	I-8
2.4.2 When connected to a FX3G PLC	I-9
2.5 Temperature Measurement	I-9
3. Wiring	I-10
3.1 Terminal Layout	I-11
3.2 Applicable Cable and Terminal Tightening Torque	I-12
3.3 Power Supply Line	I-13
3.3.1 To connect to the FX3G, FX3U Series PLC	I-13
3.3.2 To connect to the FX3UC Series PLC	I-13
3.4 Selection of the Platinum Resistance Thermometer Sensor	I-14
3.5 Wiring of the Platinum Resistance Thermometer Sensor	I-14
3.6 Grounding	I-14
4. Programming	I-15
4.1 Loading of A/D Conversion Data	I-15
4.2 List of Special Devices	I-17
4.3 Selection of Temperature Unit	I-18
4.4 Temperature Measurement	I-19
4.5 Averaging Time	I-20
4.6 Error Status	I-21
4.7 Model Code	I-24
4.8 Basic Program Example	I-25
5. Troubleshooting	I-26
5.1 PLC Version Number Check	I-26
5.2 Wiring Check	I-26
5.3 Special Device Check	I-26
5.4 Program Check	I-27
5.5 Error Status Check	I-27

FX_{3U}-4AD-PTW-ADP

(4-channel Platinum Resistance Thermometer Data Input)

1. Outline	J-3
1.1 Outline of Functions	J-3
1.2 Setup Procedure Before Starting Operation	J-4
1.3 Connectable PLC and Its Version Number	J-5
1.4 Compatible Programming Tool Version Number	J-5
2. Specifications	J-6
2.1 Generic Specifications	J-6
2.2 Power Supply Specifications	J-7
2.3 Performance Specifications	J-7
2.4 A/D Conversion Time	J-8
2.4.1 When connected to a FX3U, FX3UC PLC	J-8
2.4.2 When connected to a FX3G PLC	J-9
2.5 Temperature Measurement	J-9
3. Wiring	J-10
3.1 Terminal Layout	J-11
3.2 Applicable Cable and Terminal Tightening Torque	J-12
3.3 Power Supply Line	J-13
3.3.1 To connect to the FX3G, FX3U Series PLC	J-13
3.3.2 To connect to the FX3UC Series PLC	J-13
3.4 Selection of the Platinum Resistance Thermometer Sensor	J-14
3.5 Wiring of the Platinum Resistance Thermometer Sensor	J-14
3.6 Grounding	J-14
4. Programming	J-15
4.1 Loading of A/D Conversion Data	J-15
4.2 List of Special Devices	J-17
4.3 Selection of Temperature Unit	J-18
4.4 Temperature Measurement	J-19
4.5 Averaging Time	J-20
4.6 Error Status	J-21
4.7 Model Code	J-24
4.8 Basic Program Example	J-25
5. Troubleshooting	J-26
5.1 PLC Version Number Check	J-26
5.2 Wiring Check	J-26
5.3 Special Device Check	J-26
5.4 Program Check	J-27
5.5 Error Status Check	J-27

FX_{3U}-4AD-PNK-ADP (4-channel Resistance Thermometer Data Input)

1. Outline	K-3
1.1 Outline of Functions	K-3
1.2 Setup Procedure Before Starting Operation	K-4
1.3 Connectable PLC and Its Version Number	K-5
1.4 Compatible Programming Tool Version Number	K-5
2. Specifications	K-6
2.1 Generic Specifications	K-6
2.2 Power Supply Specifications.....	K-6
2.3 Performance Specifications	K-7
2.4 A/D Conversion Time.....	K-8
2.4.1 When connected to a FX3U, FX3UC PLC.....	K-8
2.4.2 When connected to a FX3G PLC.....	K-9
2.5 Temperature Measurement.....	K-9
3. Wiring	K-10
3.1 Terminal Layout	K-11
3.2 Applicable Cables and Terminal Tightening Torque	K-12
3.3 Power Supply Line	K-13
3.3.1 To connect to the FX3G, FX3U Series PLC.....	K-13
3.3.2 To connect to the FX3UC Series PLC.....	K-13
3.4 Selection of the Resistance Thermometer Sensor.....	K-14
3.5 Wiring of the Resistance Thermomester Sensor	K-14
3.6 Caution Regarding Wiring	K-15
3.7 Grounding	K-15
4. Programming	K-16
4.1 Loading of A/D Conversion Data.....	K-16
4.2 List of Special Devices	K-18
4.3 Selection of Temperature Unit	K-19
4.4 Input sensor selection	K-20
4.5 Temperature Measurement.....	K-21
4.6 Averaging Time	K-22
4.7 Error Status	K-23
4.8 Model Code.....	K-26
4.9 Basic Program Example.....	K-27
5. Troubleshooting	K-29
5.1 PLC Version Number Check.....	K-29
5.2 Wiring Check.....	K-29
5.3 Special Device Check	K-29
5.4 Program Check	K-30
5.5 Error Status Check.....	K-30

FX_{3U}-4AD-TC-ADP (4-channel Thermocouple Data Input)

1. Outline	L-3
1.1 Outline of Functions	L-3
1.2 Setup Procedure Before Starting Operation	L-4
1.3 Connectable PLC and Its Version Number	L-5
1.4 Compatible Programming Tool Version Number	L-5
2. Specifications	L-6
2.1 Generic Specifications	L-6
2.2 Power Supply Specifications	L-6
2.3 Performance Specifications	L-7
2.4 A/D Conversion Time	L-8
2.4.1 When connected to a FX _{3U} , FX _{3UC} PLC	L-8
2.4.2 When connected to a FX _{3G} PLC	L-9
2.5 Temperature Measurement	L-9
3. Wiring	L-10
3.1 Terminal Layout	L-11
3.2 Applicable Cables and Terminal Tightening Torque	L-12
3.3 Power Supply Line	L-13
3.3.1 To connect to the FX _{3G} , FX _{3U} Series PLC	L-13
3.3.2 To connect to the FX _{3UC} Series PLC	L-13
3.4 Selection of the Thermocouple	L-14
3.4.1 Thermocouple type	L-14
3.4.2 Compensating lead wire	L-14
3.5 Wiring of Thermocouple	L-14
3.5.1 Wiring of thermocouple type K	L-14
3.5.2 Wiring of the thermocouple type J	L-15
3.6 Caution Regarding Wiring	L-15
3.7 Grounding	L-15
4. Programming	L-16
4.1 Loading of A/D Conversion Data	L-16
4.2 List of Special Devices	L-18
4.3 Selection of Temperature Unit	L-19
4.4 Selection of Type K or J	L-20
4.5 Temperature Measurement	L-21
4.6 Averaging Time	L-22
4.7 Error Status	L-23
4.8 Model Code	L-26
4.9 Basic Program Example	L-27
5. Troubleshooting	L-29
5.1 PLC Version Number Check	L-29
5.2 Wiring Check	L-29
5.3 Special Device Check	L-29
5.4 Program Check	L-30
5.5 Error Status Check	L-30

PID Instruction (FNC 88)

1. Outline	M-3
1.1 Outline of function	M-3
1.2 Basic Operation Expressions in PID Instruction (Reference).....	M-4
2. How to Use PID Instruction	M-5
2.1 Explanation of function and operation.....	M-5
2.2 Relationship Between Parameter Setting and Auto-Tuning.....	M-6
3. Parameter	M-7
3.1 Parameter List: (S3) to (S3) + 28	M-7
3.2 Details of Parameters.....	M-9
3.2.1 Sampling time (TS): (S3)	M-9
3.2.2 Operation setting (ACT):(S3)+1.....	M-10
3.2.3 Input filter (α): (S3)+2	M-12
3.2.4 Proportional gain (KP): (S3)+3.....	M-13
3.2.5 Integral time (TI): (S3)+4	M-13
3.2.6 Differential gain (KD): (S3)+5.....	M-15
3.2.7 Differential time (TD): (S3)+6.....	M-15
3.2.8 Alarm output flag: (S3)+24	M-17
4. Auto-Tuning	M-18
4.1 Limit Cycle Method.....	M-18
4.1.1 Parameters set in auto-tuning (of limit cycle method)	M-18
4.1.2 Auto-tuning procedure	M-19
4.1.3 Reference: How to obtain three constants in PID control (limit cycle method).....	M-20
4.2 Step Response Method.....	M-21
4.2.1 Parameters to be set by auto-tuning (step response method)	M-21
4.2.2 Auto-tuning procedure	M-21
4.2.3 Reference: How to obtain three constants in PID control (step response method).....	M-22
4.3 Cautions on Auto-Tuning Execution.....	M-22
5. Example of Practical Programs (for Step Response Method)	M-23
5.1 Example: System and operation	M-23
5.2 Program example of auto-tuning (step response method) and PID control	M-24
5.3 Program example of auto-tuning (step response method).....	M-26
6. Troubleshooting	M-28
6.1 Error Codes.....	M-28
Warranty	i
Revised History	ii

MEMO

1. Introduction

This manual describes the analog products for the FX3G/FX3U/FX3UC Series PLC.
This chapter describes the analog control methods and applications.

1.1 Outline and Features of Analog Control

For the FX Series, there are 3 types of analog control: Voltage/Current input, Voltage/Current output, and Temperature Sensor input.

It is important to select products that are optimum for the purpose of use.

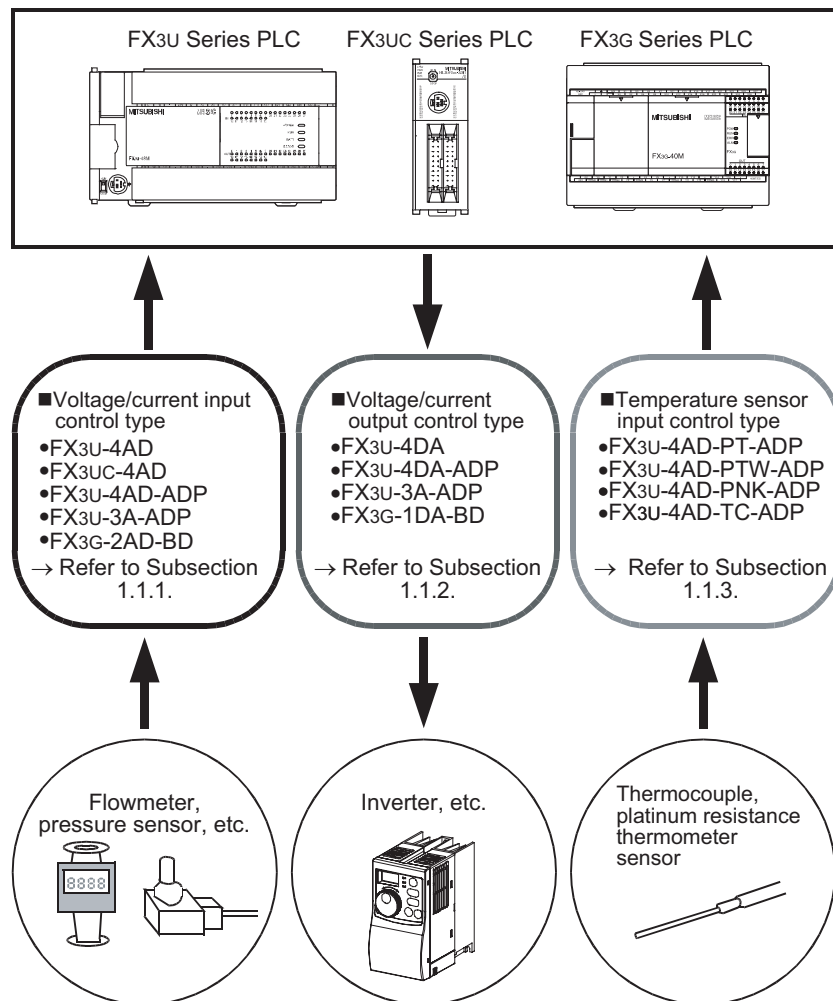

In addition to the above applications, the FX3U/FX3UC/FX3G Series PLC can be used for various purposes.

A Common Items

B FX3U-4AD
FX3UC-4AD

C FX3U-4AD-ADP

D FX3G-2AD-BD

E FX3U-4A

F FX3U-4DA-ADP

G FX3G-1DA-BD

H FX3U-3A-ADP

I FX3U-4AD-PT-ADP

J FX3U-4AD-PTW-ADP

1.1.1 Analog input control

Input the voltage/current signal from a flowmeter, pressure sensor, etc. to the PLC to monitor the condition of the workpiece or equipment.

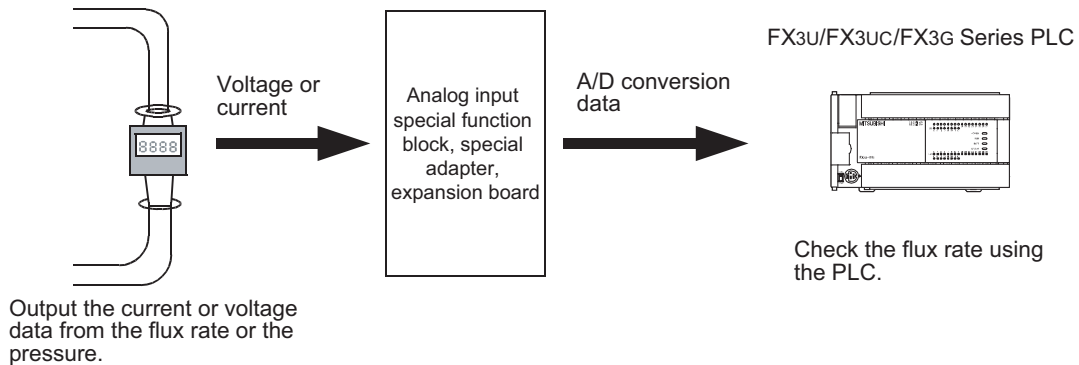

→ To determine whether or not a unit can be connected to the PLC, refer to Chapter 3 "System Configuration Drawings of Analog Products."

FX3uc Series Analog input products

- FX3UC-4AD

→ For detailed description, refer to Section B.

FX3u Series Analog input products

- FX3U-4AD
- FX3U-4AD-ADP
- FX3U-3A-ADP

→ For detailed description, refer to Section B.

→ For detailed description, refer to Section C.

→ For detailed description, refer to Section H.

FX3G Series Analog input products

- FX3G-2AD-BD

→ For detailed description, refer to Section D.

Other Series Analog input products

- FX2NC-4AD
- FX2N-4AD
- FX2N-5A
- FX2N-8AD
- FX2N-2AD
- FX0N-3A

→ For a detailed description of the other analog input products, refer to the corresponding manuals.

1.1.2 Analog output control

Output the voltage/current signal from the PLC to an inverter, etc. to control the inverter frequency, etc.

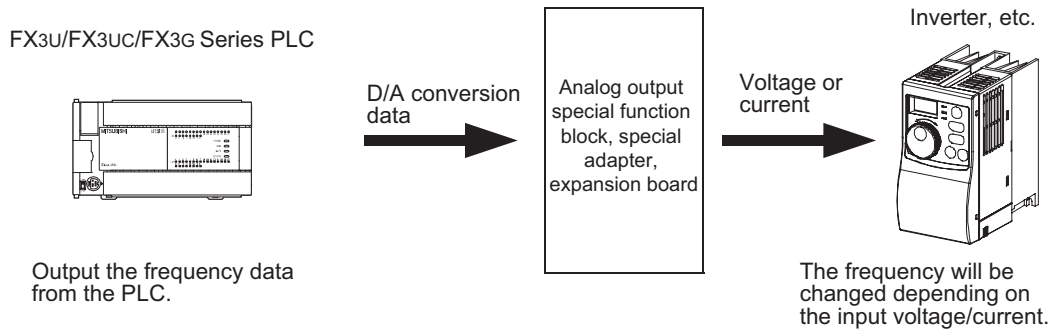

→ To determine whether or not a unit can be connected to the PLC, refer to Chapter 3 "System Configuration Drawings of Analog Products."

Analog output products for FX3U Series

- FX3U-4DA
- FX3U-4DA-ADP
- FX3U-3A-ADP

→ For detailed description, refer to Section E.

→ For detailed description, refer to Section F.

→ For detailed description, refer to Section H.

Analog output products for FX3G Series

- FX3G-1DA-BD

→ For detailed description, refer to Section G.

Other Series Analog output products

- FX2NC-4DA
- FX2N-4DA
- FX2N-2DA
- FX2N-5A
- FX0N-3A

→ For a detailed description of the other analog output products, refer to the corresponding manuals.

A

Common Items

B

FX3U-4AD
FX3UC-4AD

C

FX3U-4AD-ADP

D

FX3G-2AD-BD

E

FX3U-4DA

F

FX3U-4DA-ADP

G

FX3G-1DA-BD

H

FX3U-3A-ADP

I

FX3U-4AD-PT
-ADP

J

FX3U-4AD-PTW
-ADP

1.1.3 Temperature sensor input control

Use the PLC to check the workpiece/machine temperature measured with a thermocouple or platinum resistance thermometer sensor.

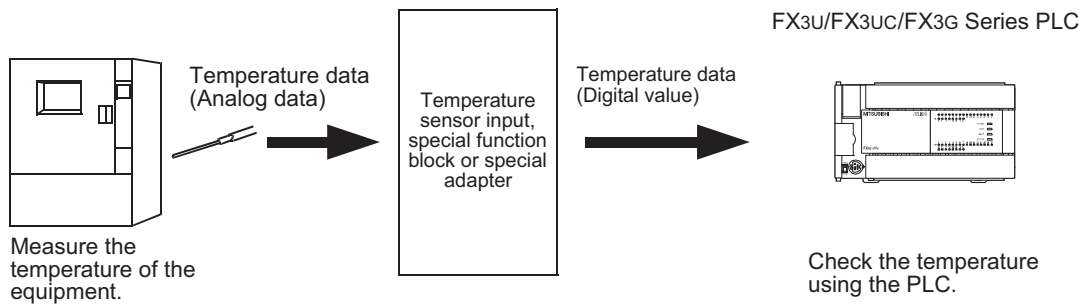

→ To determine whether or not a unit can be connected to the PLC, refer to Chapter 3 "System Configuration Drawings of Analog Products."

FX3U Series Temperature sensor input products

- FX3U-4AD-PT-ADP → For detailed description, refer to Section I.
- FX3U-4AD-PTW-ADP → For detailed description, refer to Section J.
- FX3U-4AD-PNK-ADP → For detailed description, refer to Section K.
- FX3U-4AD-TC-ADP → For detailed description, refer to Section L.
- FX3U-4LC → For detailed description, refer to the FX3U-4LC User's Manual.

Other Series Temperature sensor input products

- FX2N-8AD
 - FX2N-2LC
 - FX2N-4AD-TC
 - FX2N-4AD-PT
- For a detailed description of the other temperature sensor input products, refer to the corresponding manuals.

2. Description of Analog Products

2.1 Types of Analog Products

Analog input/output products are required to perform analog control using the FX Series PLC. There are 3 types of input/output products: the expansion board, special adapter and the special function block.

Subsequent subsections explain differences among analog products.

2.1.1 Expansion board

The analog expansion board uses PLC devices to send/receive data to/from the PLC.

1. FX3G Series PLC

- Connect analog expansion boards to option connectors of an FX3G PLC.
- Up to 2*1 analog expansion boards can be connected.

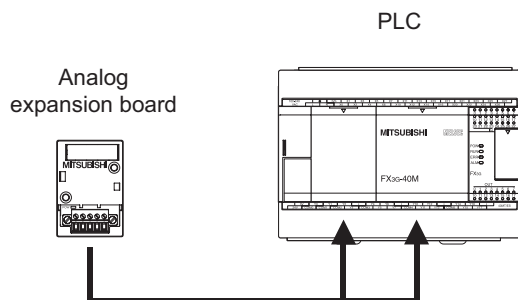

→ For a detailed description of the system configuration, refer to the **PLC User's Manual - Hardware Edition**.

- *1. Only 1 analog special adapter can be connected to the FX3G Series PLC(14-point and 24-point type). When two analog expansion boards are connected to the FX3G Series PLC(40-point or 60-point type), analog special adapters are not available in the main unit.

2.1.2 Special adapter

The analog special adapter uses PLC devices to send/receive data to/from the PLC.

1. FX3U Series PLC

- Connect the special adapter(s) to the left side of the FX3U Series PLC.
- An expansion board is needed to connect the special adapter(s).
- Up to 4 analog special adapters can be connected.
- When using the high-speed input/output special adapter(s), be sure to connect the high-speed input/output special adapter(s) first, and then connect the analog special adapter(s).

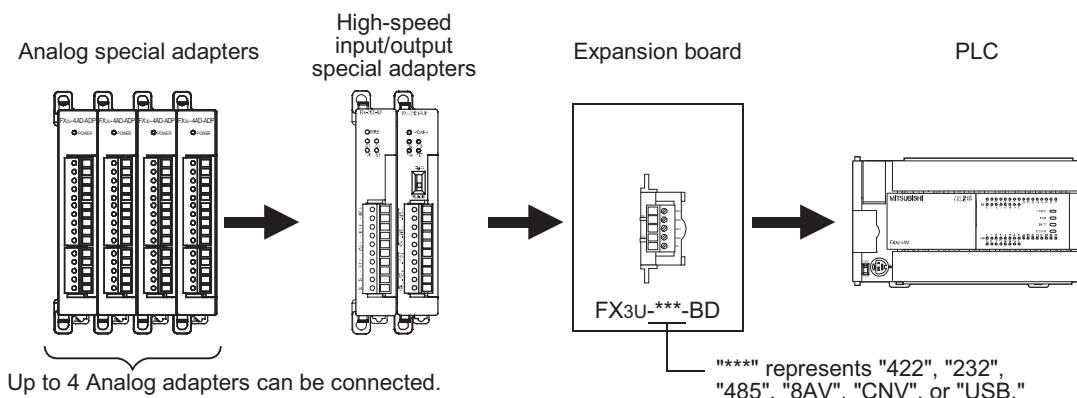

→ For a detailed description of the system configuration, refer to the PLC User's Manual - Hardware Edition.

2. FX3UC (D, DS, DSS) Series PLC

- Connect the special adapter(s) to the left side of the FX3UC (D, DS, DSS) Series PLC.
- Up to 4 analog special adapters can be connected.

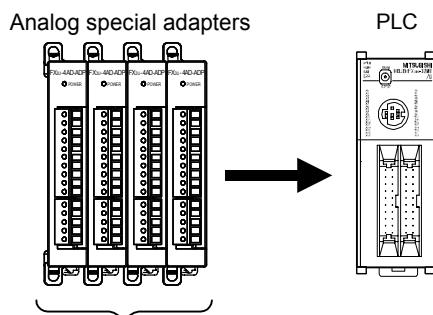

→ For a detailed description of the system configuration, refer to the PLC User's Manual - Hardware Edition.

3. FX3UC-32MT-LT(-2) PLC

- Connect the special adapter(s) to the left side of the FX3UC-32MT-LT(-2) PLC.
- An expansion board is needed to connect the special adapter(s).
- Up to 4 analog special adapters can be connected.

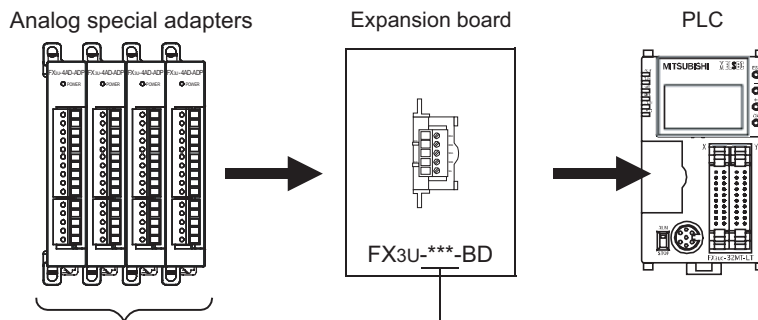

Up to 4 Analog adapters can be connected. "****" represents "422", "232", "485", "8AV", "CNV", or "USB."

→ For a detailed description of the system configuration, refer to the PLC User's Manual - Hardware Edition.

4. FX3G Series PLC

- Connect the special adapter(s) to the left side of the FX3G Series PLC.
- A connector conversion board is needed to connect the special adapter(s).
- Up to 2^{*1} analog special adapters can be connected.

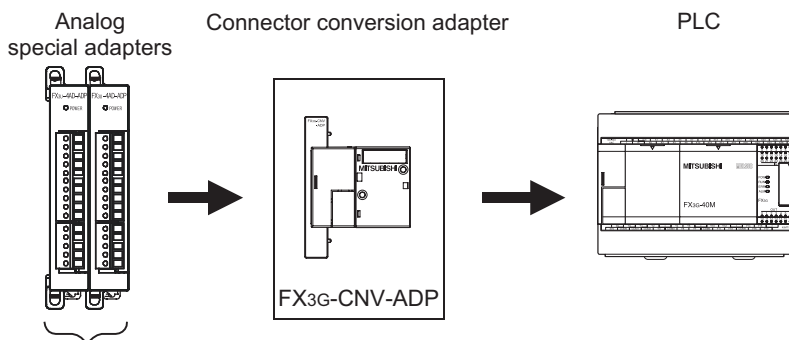

Up to 2 Analog adapters can be connected.

→ For a detailed description of the system configuration, refer to the PLC User's Manual - Hardware Edition.

- *1. Only 1 analog special adapter can be connected to the FX3G Series PLC(14-point and 24-point type). When two analog expansion boards are connected to FX3G Series PLC(40-point or 60-point type), analog special adapters are not available in the main unit.

A

Common Items

B

FX3U-4AD
FX3UC-4AD

C

FX3U-4AD-ADP

D

FX3G-2AD-BD

E

FX3U-4DA

F

FX3U-4DA-ADP

G

FX3G-1DA-BD

H

FX3U-3A-ADP

I

FX3U-4AD-PT
-ADP

J

FX3U-4AD-PTW
-ADP

2.1.3 Special function block

The special function block uses buffer memory (BFM) to send/receive data to/from the PLC.

1. FX3U Series PLC

- Connect the special function block(s) to the right side of the FX3U Series PLC.
- Up to 8 special function blocks can be connected.

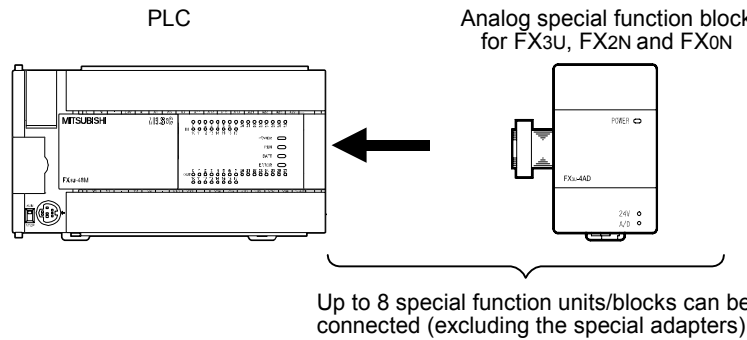

→ For a detailed description of the system configuration, refer to the PLC User's Manual - Hardware Edition.

2. FX3UC Series PLC

- Connect the special function block(s) to the right side of the FX3UC Series PLC.
- In some cases, FX2NC-CNV-IF or FX3UC-1PS-5V may be needed for connection.
- Up to 8*1 special function blocks can be connected.

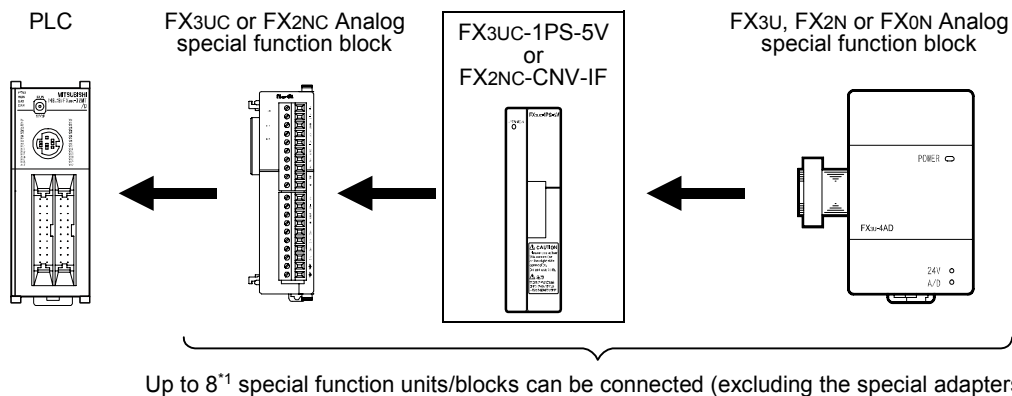

*1. Up to 7 special function units/blocks can be connected to the FX3UC-32MT-LT(-2) PLC.

Select either FX3UC-1PS-5V or FX2NC-CNV-IF considering the current components consumption.

→ For a detailed description of the system configuration, refer to the PLC User's Manual - Hardware Edition.

3. FX3G Series PLC

- Connect the special function block(s) to the right side of the FX3G Series PLC.
- Up to 8 special function blocks can be connected.

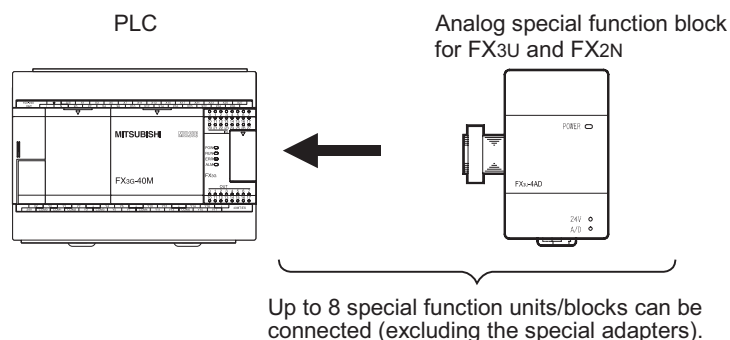

→ For a detailed description of the system configuration, refer to the PLC User's Manual - Hardware Edition.

2.2 List of Analog Product Models

The analog input/output products compatible with the FX3U/FX3UC/FX3G Series PLC are described below:

2.2.1 Expansion board

- FX3G Series PLC

Type	No. of channels	Range	Resolution	Function	Reference
Voltage/current input					
FX3G-2AD-BD	2ch	Voltage: 0V to 10V DC	2.5mV(12bits)	Combined use of voltage and current inputs is possible.	D
		Current: 4mA to 20mA DC	8μA(11bits)		
Voltage/current output					
FX3G-1DA-BD	1ch	Voltage: 0V to 10V DC	2.5mV(12bits)	Voltage and current output.	G
		Current: 4mA to 20mA DC	8μA(11bits)		

2.2.2 Special adapter

Type	No. of channels	Range	Resolution	Function	Reference
Voltage/current input					
FX3U-4AD-ADP	4ch	Voltage: 0V to 10V DC	2.5mV(12bits)	Combined use of voltage and current inputs is possible.	C
		Current: 4mA to 20mA DC	10μA(11bits)		
Voltage/current output					
FX3U-4DA-ADP	4ch	Voltage: 0V to 10V DC	2.5mV(12bits)	Combined use of voltage and current outputs is possible.	F
		Current: 4mA to 20mA DC	4μA(12bits)		
Voltage/current input/output mixture					
FX3U-3A-ADP	Input 2ch	Voltage: 0V to 10V DC	2.5mV(12bits)	Combined use of voltage/ current inputs and voltage/ current output is possible.	H
		Current: 4mA to 20mA DC	5μA(12bits)		
	Output 1ch	Voltage: 0V to 10V DC	2.5mV(12bits)		
		Current: 4mA to 20mA DC	4μA(12bits)		
Temperature sensor input					
FX3U-4AD-PT-ADP	4ch	Pt100: -50°C to +250°C	0.1°C	Compatible with the platinum resistance thermometer sensor (Pt100). The product can be switched between "Centigrade" and "Fahrenheit."	I
FX3U-4AD-PTW-ADP	4ch	Pt100: -100°C to +600°C	0.2°C to 0.3°C	Compatible with the platinum resistance thermometer sensor (Pt100). The product can be switched between "Centigrade" and "Fahrenheit."	J
FX3U-4AD-PNK-ADP	4ch	Pt1000: -50°C to +250°C	0.1°C	Compatible with the input sensor (Pt1000 and Ni1000). The product can be switched between "Centigrade" and "Fahrenheit."	K
		Ni1000: -45°C to +115°C			
FX3U-4AD-TC-ADP	4ch	Type K: -100°C to +1000°C	0.4°C	Compatible with thermocouple types K and J. The product can be switched between "Centigrade" and "Fahrenheit."	L
		Type J: -100°C to +600°C	0.3°C		

2.2.3 Special function block

Type	No. of channels	Range	Resolution	Function	Reference
Voltage/current input					
FX3U-4AD* ¹	4ch	Voltage: -10V to +10V DC	0.32mV (with sign, 16 bits)	Combined use of voltage and current inputs is possible. The offset/gain can be adjusted.* ³ The sampling function is incorporated.	B
		Current: -20mA to +20mA DC	1.25μA (with sign, 15 bits)		
FX3UC-4AD* ²	4ch	Voltage: -10V to +10V DC	0.32mV (with sign, 16 bits)	Combined use of voltage and current inputs is possible. The offset/gain can be adjusted.* ³ The sampling function is incorporated.	B
		Current: -20mA to +20mA DC	1.25μA (with sign, 15 bits)		
FX2NC-4AD* ²	4ch	Voltage: -10V to +10V DC	0.32mV (with sign, 16 bits)	Combined use of voltage and current inputs is possible. The offset/gain can be adjusted.* ³ The sampling function is incorporated.	* ⁵
		Current: -20mA to +20mA DC	1.25μA (with sign, 15 bits)		
FX2N-8AD* ¹	8ch	Voltage: -10V to +10V DC	0.63mV (with sign, 15 bits)	Combined use of voltage, current, and thermocouple is possible. The offset/gain can be adjusted.* ³ The sampling function is incorporated.	* ⁵
		Current: -20mA to +20mA DC	2.5μA (with sign, 14 bits)		
FX2N-4AD* ¹	4ch	Voltage: -10V to +10V DC	5mV (with sign, 12 bits)	Combined use of voltage and current inputs is possible. The offset/gain can be adjusted.	* ⁵
		Current: -20mA to +20mA DC	10μA (with sign, 11 bits)		
FX2N-2AD* ¹	2ch	Voltage: 0V to 10V DC	2.5mV (12bits)	Combined use of voltage and current inputs is impossible. The offset/gain can be adjusted. (Common to 2 input channels)	* ⁵
		Current: 4mA to 20mA DC	4μA (12bits)		
Voltage/current output					
FX3U-4DA* ¹	4ch	Voltage: -10V to +10V DC	0.32mV (with sign, 16 bits)	Combined use of voltage and current outputs is possible.* ⁴ The offset/gain can be adjusted.	E
		Current: 0mA to 20mA DC	0.63μA (15bits)		
FX2NC-4DA* ²	4ch	Voltage: -10V to +10V DC	5mV (with sign, 12 bits)	Combined use of voltage and current outputs is possible. The offset/gain can be adjusted.	* ⁵
		Current: 0mA to 20mA DC	20μA (10bits)		
FX2N-4DA* ¹	4ch	Voltage: -10V to +10V DC	5 mV (with sign, 12 bits)	Combined use of voltage and current outputs is possible. The offset/gain can be adjusted.	* ⁵
		Current: 0mA to 20mA DC	20μA (10bits)		
FX2N-2DA* ¹	2ch	Voltage: 0V to 10V DC	2.5 mV (12 bits)	Combined use of voltage and current outputs is possible. The offset/gain can be adjusted.	* ⁵
		Current: 4mA to 20mA DC	4μA (12bits)		

*1. To connect this block to the FX3UC Series PLC, either the FX2NC-CNV-IF or FX3UC-1PS-5V is required.

*2. Connectable with the FX3UC Series PLC only.

*3. The offset and gain of the FX3U-4AD, FX3UC-4AD, FX2NC-4AD and FX2N-8AD cannot be adjusted for channels using the analog value direct indication mode.

*4. The offset and gain of the FX3U-4DA cannot be adjusted for channels using the analog value mV (or μA) specification mode.

*5. Refer to the instruction manual of the respective product.

Type	No. of channels	Range	Resolution	Function	Reference
Voltage/current input/output mixture					
FX2N-5A*1	Input 4ch	Voltage: -10V to +10V DC	0.32mV (with sign, 16 bits)	Combined use of voltage and current is possible. The offset/gain can be adjusted.*3 The scaling function is incorporated.	*2
		Current: -20mA to +20mA DC	1.25μA (with sign, 15 bits)		
	Output 1ch	Voltage: -10V to +10V DC	5mV (with sign, 12 bits)		
		Current: 0mA to 20mA DC	20μA (10bits)		
FX0N-3A*1, *4	Input 2ch	Voltage: 0V to 10V DC	40mV (8bits)	The input format is common to 2 channels. The offset/gain can be adjusted. (Common to 2 input channels)	*2
		Current: 4mA to 20mA DC	64μA (8bits)		
	Output 1ch	Voltage: 0V to 10V DC	40mV (8bits)		
		Current: 4mA to 20mA DC	64μA (8bits)		
Temperature sensor input					
FX2N-8AD*1	8ch	Type K: -100°C to +1200°C	0.1°C	Combined use of voltage, current, and thermocouple is possible. Compatible with thermocouple types K, J, and T. The unit can be switched between "Centigrade" and "Fahrenheit." The sampling function is incorporated.	*2
		Type J: -100°C to +600°C			
		Type T: -100°C to +350°C			
FX2N-4AD-TC*1	4ch	Type K: -100°C to +1200°C	0.4°C	Compatible with thermocouple types K and J. The unit can be switched between "Centigrade" and "Fahrenheit."	*2
		Type J: -100°C to +600°C	0.3°C		
FX2N-4AD-PT*1	4ch	Pt100: -100°C to +600°C	0.2°C to 0.3°C	Compatible with the platinum resistance thermometer sensor (Pt100 or JPt100). The unit can be switched between "Centigrade" and "Fahrenheit."	*2
FX3U-4LC*1	4ch	Example: Type K: -100°C to +1300°C Example: Pt100: -200°C to +600°C	0.1°C or 1°C (Depends on the sensor input range.)	Compatible with thermocouple types K, J, R, S, E, T, B, N, PL II, W5Re/W26Re, U, and L. Compatible with the platinum resistance thermometer sensor (Pt1000, Pt100, and JPt100). The unit can be switched between "Centigrade" and "Fahrenheit." Compatible with the micro voltage input. The temperature adjustment function (PID operation, etc.) is incorporated. The peak disconnection detection function is incorporated. (A CT sensor is needed.)	*2

*1. To connect this block to the FX3UC Series PLC, either the FX2NC-CNV-IF or FX3UC-1PS-5V is required.

*2. Refer to the instruction manual of the respective product.

*3. The offset and gain of the FX2N-5A cannot be adjusted for channels using the analog value direct indication mode or analog value mV (or μA) specification mode.

*4. The FX0N-3A cannot be connected to the FX3G Series PLC.

Type	No. of channels	Range	Resolution	Function	Reference
Temperature sensor input					
FX2N-2LC*1	2ch	Example: Type K: -600°C to +1300°C <hr/> Example: Pt100: -200°C to +600°C	0.1°C or 1°C (Depends on the sensor input range.)	Compatible with thermocouple types K, J, R, S, E, T, B, N, PL II, W5Re/W26Re, U, and L. Compatible with the platinum resistance thermometer sensor (Pt100, JPt100). The unit can be switched between "Centigrade" and "Fahrenheit." The temperature adjustment function (PID operation, etc.) is incorporated. The peak disconnection detection function is incorporated. (A CT sensor is needed.)	*2

*1. To connect this block to the FX3UC Series PLC, either the FX2NC-CNV-IF or FX3UC-1PS-5V is required.

*2. Refer to the instruction manual of the respective product.

3. System Configuration Drawings of Analog Products

This section shows drawings to describe the configuration of analog units for the FX3U/FX3UC/FX3G Series PLC.

3.1 FX3U Series PLC

3.1.1 Connection of special adapters

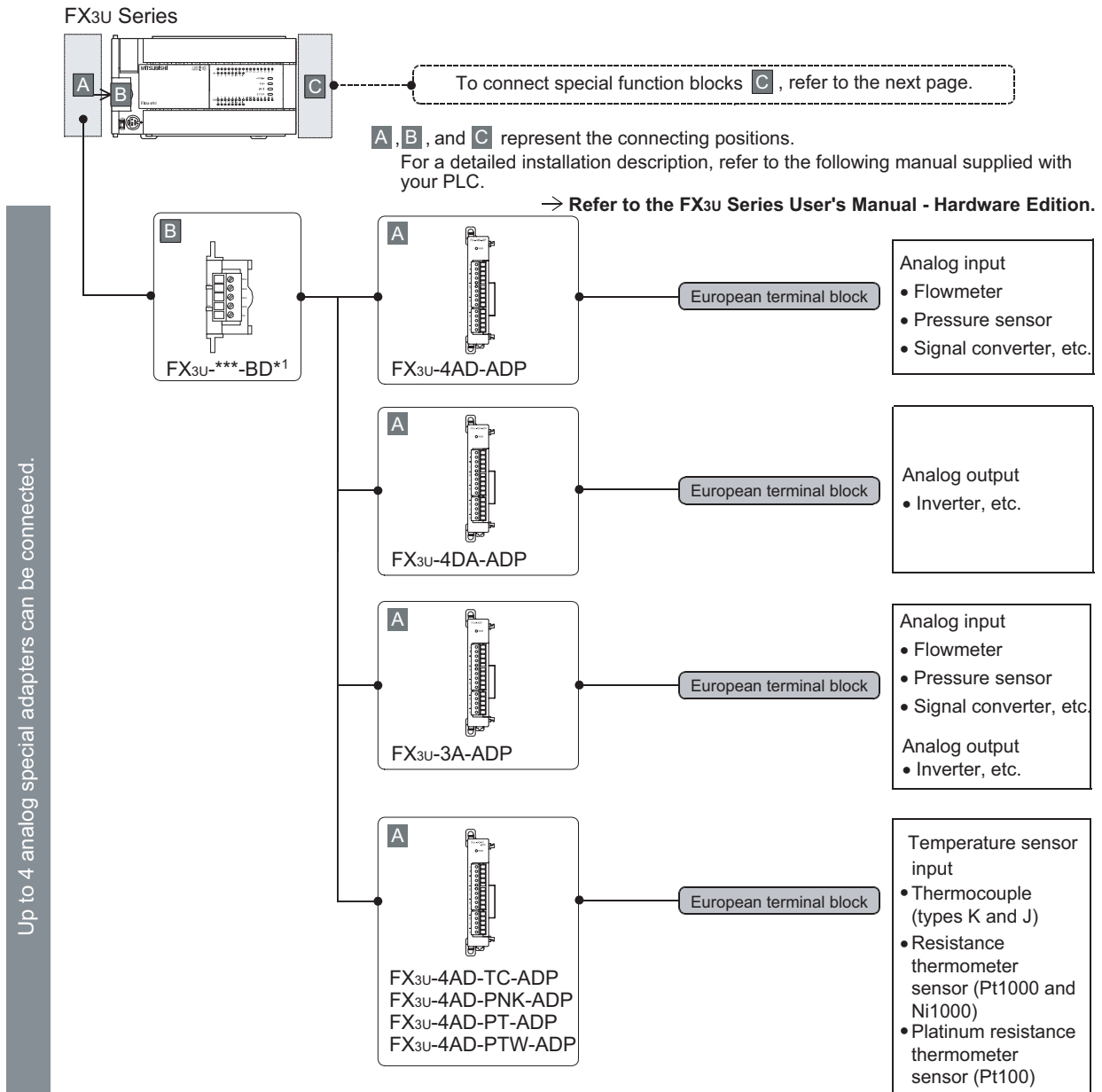

*1. An FX3U-232-BD, FX3U-485-BD, FX3U-422-BD, FX3U-USB-BD, FX3U-8AV-BD, or FX3U-CNV-BD is needed to connect the special adapters.

A Common Items

B FX3U-4AD
FX3UC-4AD

C FX3U-4AD-ADP

D FX3G-2AD-BD

E FX3U-4DA

F FX3U-4DA-ADP

G FX3G-1DA-BD

H FX3U-3A-ADP

I FX3U-4AD-PT-ADP

J FX3U-4AD-PTW-ADP

3.1.2 Connection of special function blocks

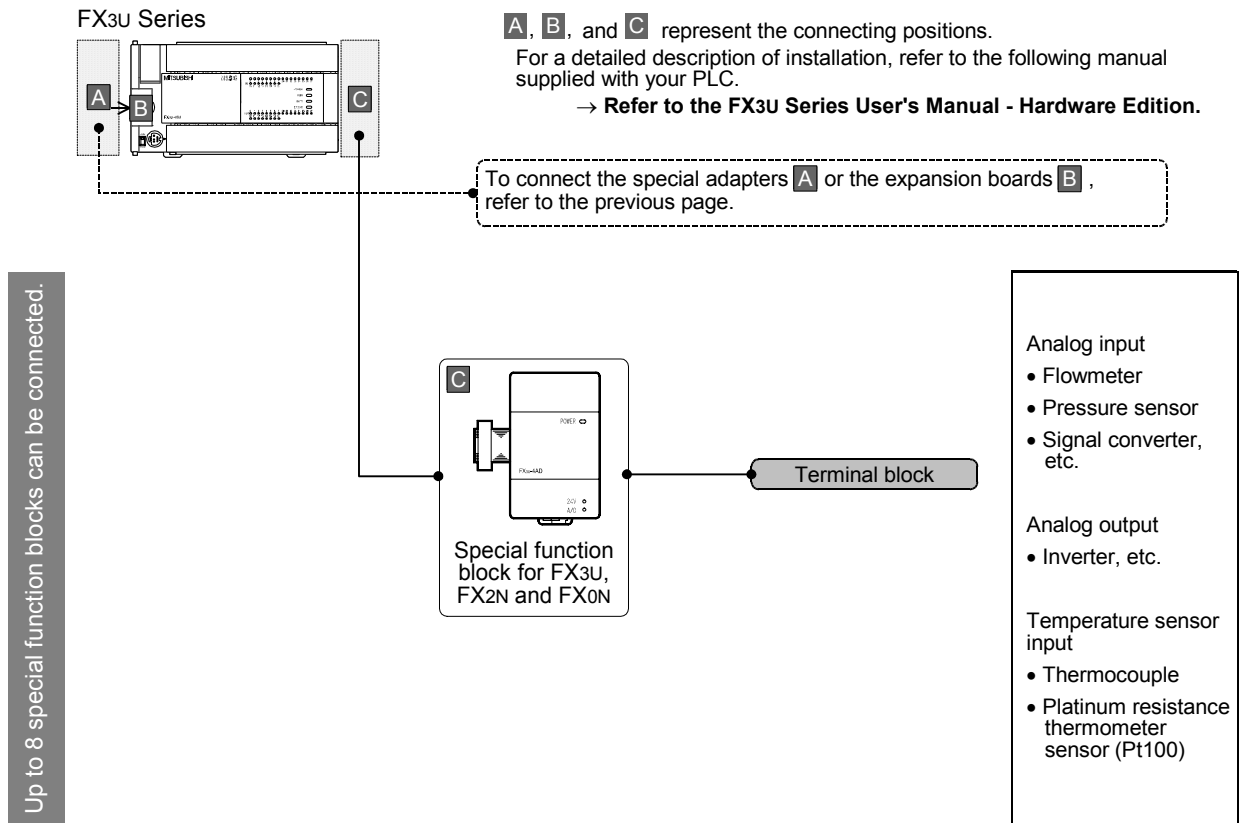

- For a detailed description of the connectable special function blocks and system configuration:
→ **Refer to the FX3U Series User's Manual - Hardware Edition.**

The analog special function blocks shown in the table below can be connected to the FX3U Series PLC:

FX Series	Type
Analog special function blocks for the FX3U	FX3U-4AD, FX3U-4DA, FX3U-4LC
Analog special function blocks for the FX2N	FX2N-8AD, FX2N-4AD, FX2N-2AD, FX2N-4DA, FX2N-2DA, FX2N-5A, FX2N-4AD-PT, FX2N-4AD-TC, FX2N-2LC
Analog special function blocks for the FX0N	FX0N-3A

3.2 FX3UC Series PLC

3.2.1 Connection of special adapters

1. FX3uc (D, DS, DSS) Series PLC

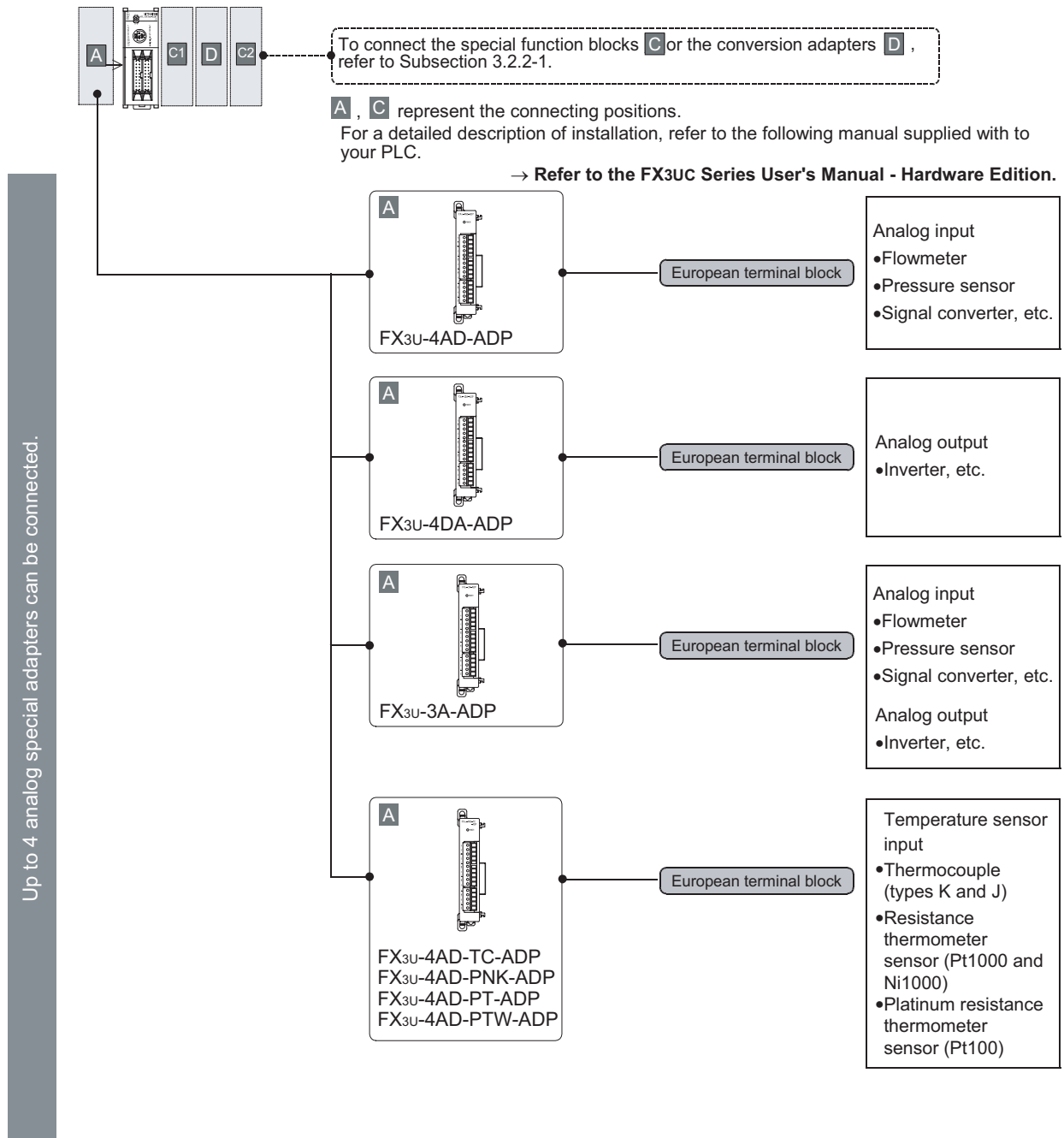

A	Common Items
B	FX3U-4AD FX3UC-4AD
C	FX3U-4AD-ADP
D	FX3G-2AD-BD
E	FX3U-4DA
F	FX3U-4DA-ADP
G	FX3G-1DA-BD
H	FX3U-3A-ADP
I	FX3U-4AD-PT-ADP
J	FX3U-4AD-PTW-ADP

2. FX3uc-32MT-LT(-2) PLC

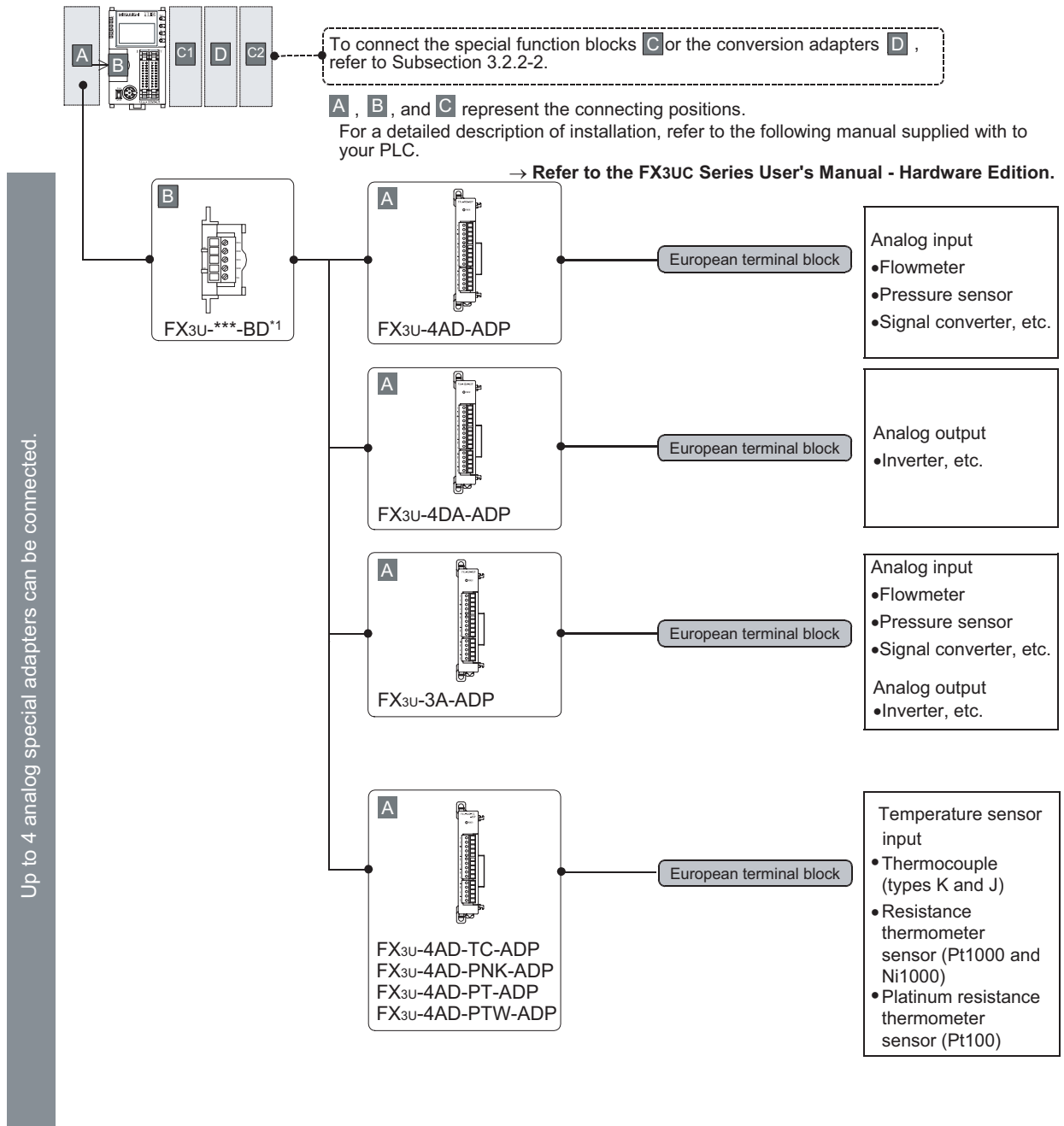

*1. An FX3U-232-BD, FX3U-485-BD, FX3U-422-BD, FX3U-USB-BD, FX3U-8AV-BD, or FX3U-CNV-BD is needed to connect the special adapters.

3.2.2 Connection of special function blocks

1. FX3uc (D, DS, DSS) Series PLC

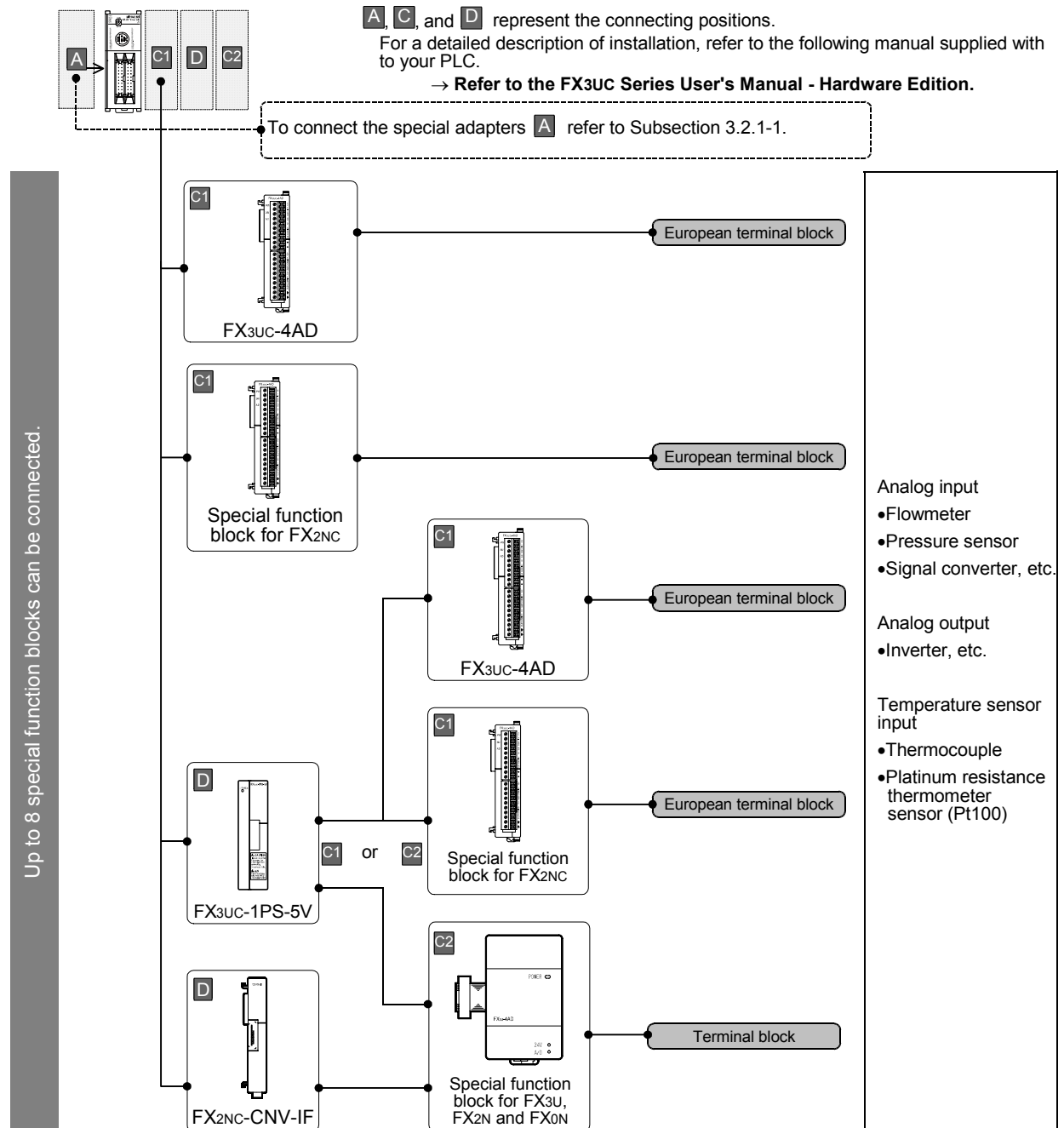

- For a detailed description of special function block connectability and system configuration:
→ Refer to the FX3uc Series User's Manual - Hardware Edition.
- Use the FX3UC-1PS-5V (extension power supply unit) if the capacity of the 5V DC power supply unit incorporated in the FX3UC Series PLC is deteriorated.
→ Refer to the FX3uc Series User's Manual - Hardware Edition.

The analog special function blocks shown in the table below can be connected to the FX3UC Series PLC:

FX Series	Type
Analog special function blocks for the FX3U	FX3U-4AD, FX3U-4DA, FX3U-4LC
Analog special function blocks for the FX2NC	FX2NC-4AD, FX2NC-4DA
Analog special function blocks for the FX2N	FX2N-8AD, FX2N-4AD, FX2N-2AD, FX2N-4DA, FX2N-2DA, FX2N-5A, FX2N-4AD-PT, FX2N-4AD-TC, FX2N-2LC
Analog special function blocks for the FX0N	FX0N-3A

2. FX3uc-32MT-LT(-2) PLC

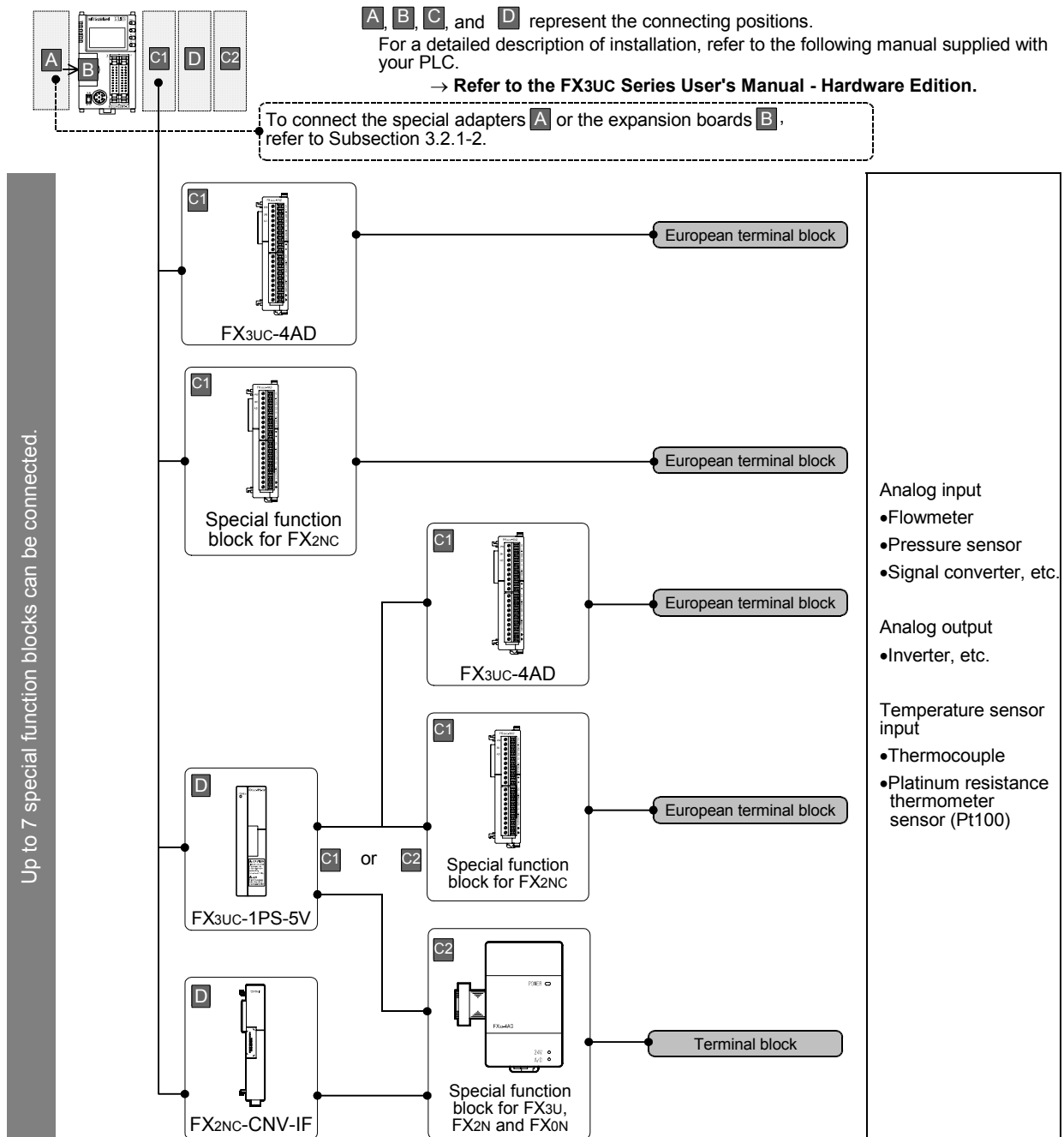

- For a detailed description of special function block connectability and system configuration:
→ Refer to the FX3uc Series User's Manual - Hardware Edition.
- Use the FX3uc-1PS-5V (extension power supply unit) if the capacity of the 5V DC power supply unit incorporated in the FX3uc Series PLC is deteriorated.
→ Refer to the FX3uc Series User's Manual - Hardware Edition.

The analog special function blocks shown in the table below can be connected to the FX3uc Series PLC:

FX Series	Type
Analog special function blocks for the FX3U	FX3U-4AD, FX3U-4DA, FX3U-4LC
Analog special function blocks for the FX2NC	FX2NC-4AD, FX2NC-4DA
Analog special function blocks for the FX2N	FX2N-8AD, FX2N-4AD, FX2N-2AD, FX2N-4DA, FX2N-2DA, FX2N-5A, FX2N-4AD-PT, FX2N-4AD-TC, FX2N-2LC
Analog special function blocks for the FX0N	FX0N-3A

3.3 FX3G Series PLC

3.3.1 Connection of expansion boards, special adapters

1. FX3G Series PLC (14-point, 24-point type)

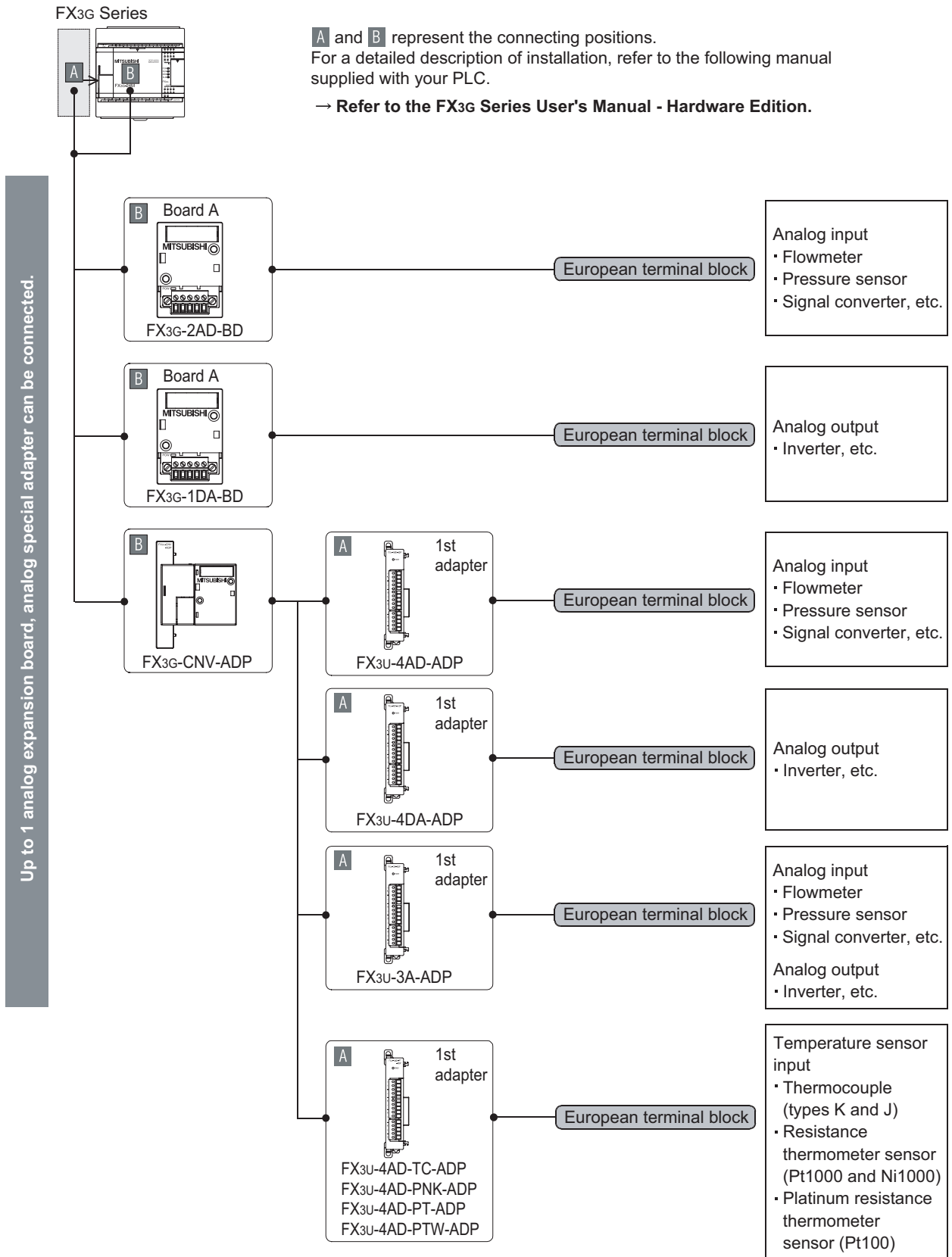

A	Common Items
B	FX3U-4AD FX3UC-4AD
C	FX3U-4AD-ADP
D	FX3G-2AD-BD
E	FX3U-4DA
F	FX3U-4DA-ADP
G	FX3G-1DA-BD
H	FX3U-3A-ADP
I	FX3U-4AD-PT -ADP
J	FX3U-4AD-PTW -ADP

3.3.2 Connection of special function blocks

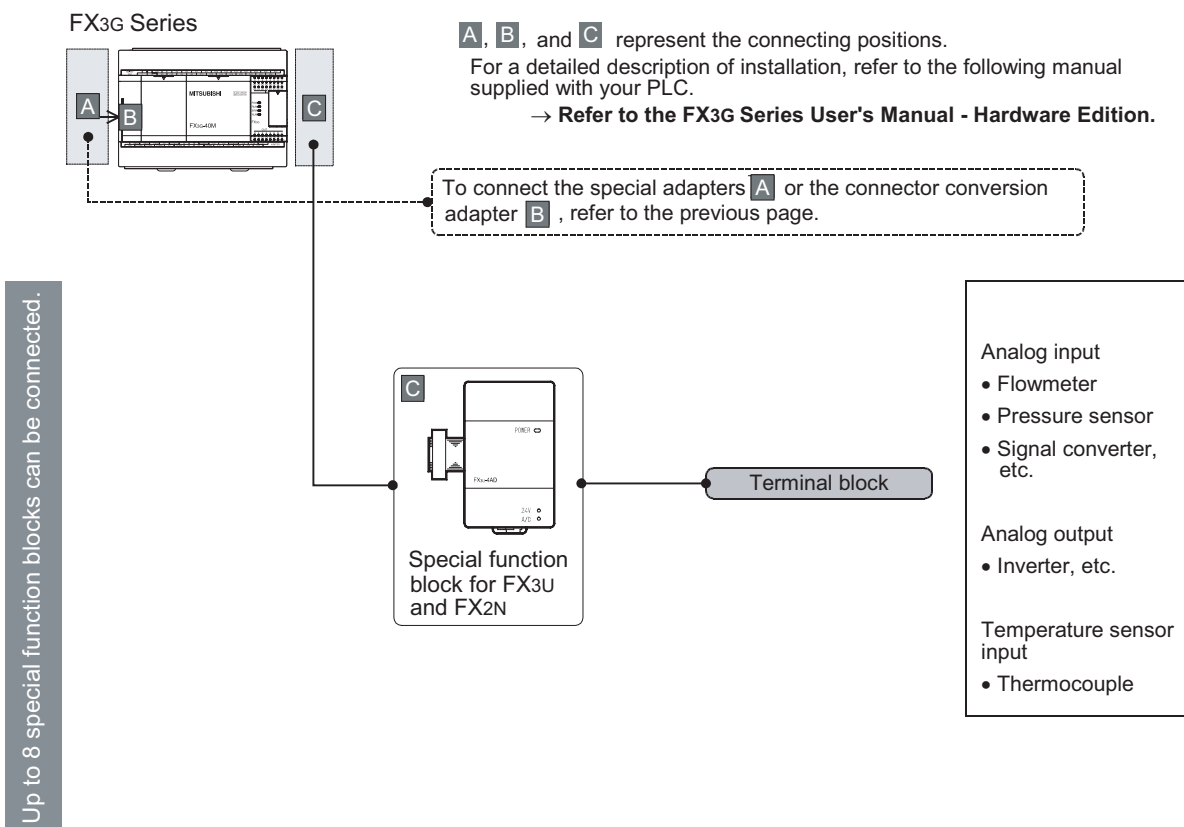

- For a detailed description of the connectable special function blocks and system configuration:
→ Refer to the FX3G Series User's Manual - Hardware Edition.

The analog special function blocks shown in the table below can be connected to the FX3G Series PLC:

FX Series	Type
Analog special function blocks for the FX3U	FX3U-4AD, FX3U-4DA, FX3U-4LC
Analog special function blocks for the FX2N	FX2N-8AD, FX2N-4AD, FX2N-2AD, FX2N-4DA, FX2N-2DA, FX2N-5A, FX2N-4AD-PT, FX2N-4AD-TC, FX2N-2LC

A	Common Items
B	FX3U-4AD FX3UC-4AD
C	FX3U-4AD-ADP
D	FX3G-2AD-BD
E	FX3U-4DA
F	FX3U-4DA-ADP
G	FX3G-1DA-BD
H	FX3U-3A-ADP
I	FX3U-4AD-PT -ADP
J	FX3U-4AD-PTW -ADP

4. Comparison of Performance Specifications

The analog product performance specifications are shown in the following tables. Select the optimal product for your equipment.

4.1 Analog Input

4.1.1 FX3U-4AD-ADP

Specifications		FX3U-4AD-ADP	
		Voltage input	Current input
Number of input points		4ch	
Analog input range		0V to 10V DC (Input resistance: 194 kΩ)	4mA to 20mA DC (Input resistance: 250 Ω)
Absolute maximum input		-0.5V,+15V	-2mA,+30mA
Offset		Impossible to change	Impossible to change
Gain			
Digital output		12 bits, binary	11 bits, binary
Resolution		2.5mV(10V×1/4000)	10μA(16mA×1/1600)
Overall accuracy	Ambient temperature :25±5°C	±0.5%(±50mV) for 10V full scale	±0.5%(±80μA) for 16mA full scale
	Ambient temperature :0 to 55°C	±1.0%(±100mV) for 10V full scale	±1.0%(±160μA) for 16mA full scale
Time required for A/D conversion		<ul style="list-style-type: none"> FX3U/FX3UC Series PLC : 200μs (Data updated every scan time.) FX3G Series PLC : 250μs (Data updated every scan time.) 	
Input characteristics			
Insulation method		<ul style="list-style-type: none"> The photocoupler is used to insulate the analog input area from the PLC. The DC/DC converter is used to insulate the power supply from the analog inputs. Channels are not insulated from each other. 	
Number of I/O points occupied		0 point (This number is not related to the maximum I/O points of the PLC.)	

4.1.2 FX2N-2AD

Specifications	FX2N-2AD	
	Voltage input	Current input
Number of input points	2ch	
Analog input range*1	0V to 5V DC 0V to 10V DC (Input resistance: 200 kΩ)	4mA to 20mA DC (Input resistance: 250Ω)
Absolute maximum input	-0.5V, +15V	-2mA, +60mA
Offset	If the digital value is "0": 0V to 1V*2,*3	If the digital value is "0": 0mA to 4mA*2,*3
Gain	If the digital value is "4000": 5V to 10V*2,*3	If the digital value is "4000": 20mA*2,*3
Digital output	12 bits, binary	
Resolution	2.5mV(10V×1/4000)*3	4.00μA(16mA×1/4000)*3
Overall accuracy	Ambient temperature: 25±5°C	-
	Ambient temperature: 0 to 55°C	±1.0%(±100mV) for 10V full scale
Time required for A/D conversion	2.5ms × number of selected channels (Operation synchronized with sequence program)	
Input characteristics		
Insulation method	<ul style="list-style-type: none"> The photocoupler is used to insulate the analog input area from the PLC. Channels are not insulated from each other. 	
Number of I/O points occupied	8 points (Taken from either the input or output points of the PLC.)	

- *1. For FX2N-2AD, combined use of the voltage and current inputs is not possible.
- *2. Use the adjustment volume to adjust FX2N-2AD.
- *3. Adjustment of the offset or gain value will change the resolution.

A	Common Items
B	FX3U-4AD FX3UC-4AD
C	FX3U-4AD-ADP
D	FX3G-2AD-BD
E	FX3U-4DA
F	FX3U-4DA-ADP
G	FX3G-1DA-BD
H	FX3U-3A-ADP
I	FX3U-4AD-PT -ADP
J	FX3U-4AD-PTW -ADP

4.1.3 FX3U-4AD

Specifications		FX3U-4AD	
		Voltage input	Current input
Number of input points		4ch	
Analog input range		-10V to +10V DC (Input resistance: 200 kΩ)	-20mA to +20mA DC 4mA to 20mA DC (Input resistance: 250 Ω)
Absolute maximum input		±15V	±30mA
Offset		-10V to +9V ^{*1,*2}	-20mA to +17mA ^{*1,*3}
Gain		-9V to +10V ^{*1,*2}	-17mA to +30mA ^{*1,*3}
Digital output		With sign, 16 bits, binary	With sign, 15 bits, binary
Resolution ^{*4}		0.32mV(20V×1/64000) 2.5mV(20V×1/8000)	1.25μA(40mA×1/32000) 5.00μA(40mA×1/8000)
Overall accuracy	Ambient temperature: 25±5°C	±0.3%(±60mV) for 20V full scale	±0.5%(±200μA) for 40mA full scale Same accuracy for 4mA to 20mA input
	Ambient temperature: 0 to 55°C	±0.5%(±100mV) for 20V full scale	±1.0%(±400μA) for 40mA full scale Same accuracy for 4mA to 20mA input
Time required for A/D conversion		500μs × number of selected channels ^{*5}	
Input characteristics ^{*4}		<p>●When the input mode is set to "0":</p>	<p>●When the input mode is set to "6":</p> <p>●When the input mode is set to "3":</p>
Insulation method		<ul style="list-style-type: none"> • The photocoupler is used to insulate the analog input area from the PLC. • The DC/DC converter is used to insulate the power supply from the analog inputs. • Channels are not insulated from each other. 	
Number of I/O points occupied		8 points (Taken from either the input or output points of the PLC.)	

- *1. Adjustment of the offset or gain value will not affect the resolution. In the direct indication mode, however, the offset/gain cannot be adjusted.
- *2. The offset and the gain should satisfy the following condition:
 $1V \leq (\text{Gain} - \text{Offset})$
- *3. The offset and the gain should satisfy the following condition:
 $3mA \leq (\text{Gain} - \text{Offset}) \leq 30mA$
- *4. The resolution and the input/output characteristics depend on the selected mode.
- *5. If 1 or more channels use the digital filter(s), the time required for A/D conversion will be
"5 ms × number of selected channels."

4.1.4 FX2N-4AD

Specifications	FX2N-4AD	
	Voltage input	Current input
Number of input points	4ch	
Analog input range	-10V to +10V DC (Input resistance: 200kΩ)	-20mA to +20mA DC 4mA to 20mA DC (Input resistance: 250 Ω)
Absolute maximum input	±15V	±32mA
Offset	-5V to +5V ^{*1,*2}	-20mA to +20mA ^{*1,*3}
Gain	-4V to +15V ^{*1,*2}	-16mA to +32mA ^{*1,*3}
Digital output	With sign, 12 bits, binary	With sign, 11 bits, binary
Resolution	5mV(20V×1/4000) ^{*1}	20μA(40mA×1/2000) ^{*1}
Overall accuracy	Ambient temperature: 25±5°C	-
	Ambient temperature: 0 to 55°C	±1.0%(±200mV) for 20V full scale
Time required for A/D conversion	Normal conversion mode: 15ms × number of selected channels High-speed conversion mode: 6ms × number of selected channels	
Input characteristics		<p>●When the input is set from -20 mA to +20 mA:</p> <p>●When the input is set from 4 mA to 20 mA:</p>
Insulation method	<ul style="list-style-type: none"> The photocoupler is used to insulate the analog input area from the PLC. The DC/DC converter is used to insulate the power supply from the analog inputs. Channels are not insulated from each other. 	
Number of I/O points occupied	8 points (Taken from either the input or output points of the PLC.)	

*1. Adjustment of the offset or gain value will not affect the resolution.

*2. The offset and the gain should satisfy the following condition:
 $1V \leq (\text{Gain} - \text{Offset}) \leq 15V$

*3. The offset and the gain should satisfy the following condition:
 $4mA \leq (\text{Gain} - \text{Offset}) \leq 32mA$

A	Common Items
B	FX3U-4AD FX3UC-4AD
C	FX3U-4AD-ADP
D	FX3G-2AD-BD
E	FX3U-4DA
F	FX3U-4DA-ADP
G	FX3G-1DA-BD
H	FX3U-3A-ADP
I	FX3U-4AD-PT -ADP
J	FX3U-4AD-PTW -ADP

4.1.5 FX3UC-4AD

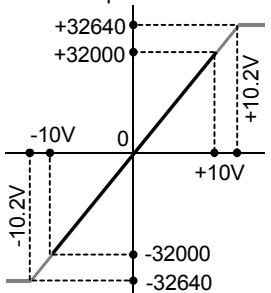
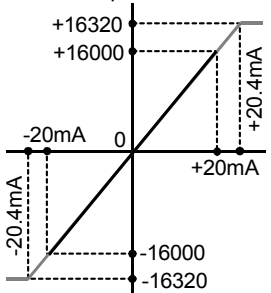
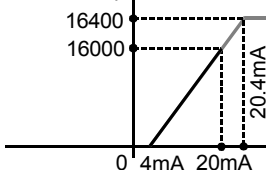
Specifications		FX3UC-4AD	
		Voltage input	Current input
Number of input points		4ch	
Analog input range		-10V to +10V DC (Input resistance: 200 kΩ)	-20mA to +20mA DC 4mA to 20mA DC (Input resistance: 250 Ω)
Absolute maximum input		±15V	±30mA
Offset		-10V to +9V ^{*1,*2}	-20mA to +17mA ^{*1,*3}
Gain		-9V to +10V ^{*1,*2}	-17mA to +30mA ^{*1,*3}
Digital output		With sign, 16 bits, binary	With sign, 15 bits, binary
Resolution ^{*4}		0.32mV(20V×1/64000) 2.5mV(20V×1/8000)	1.25μA(40mA×1/32000) 5.00μA(40mA×1/8000)
Overall accuracy	Ambient temperature: 25±5°C	±0.3%(±60mV) for 20V full scale	±0.5%(±200μA) for 40mA full scale Same accuracy for 4mA to 20mA input
	Ambient temperature: 0 to 55°C	±0.5%(±100mV) for 20V full scale	±1.0%(±400μA) for 40mA full scale Same accuracy for 4mA to 20mA input
Time required for A/D conversion		500μs × number of selected channels ^{*5}	
Input characteristics ^{*4}		<p>●When the input mode is set to "0":</p> 	<p>●When the input mode is set to "6":</p>  <p>●When the input mode is set to "3":</p> 
Insulation method		<ul style="list-style-type: none"> The photocoupler is used to insulate the analog input area from the PLC. The DC/DC converter is used to insulate the power supply from the analog inputs. Channels are not insulated from each other. 	
Number of I/O points occupied		8 points (Taken from either the input or output points of the PLC.)	

- *1. Adjustment of the offset or gain value will not affect the resolution. In the direct indication mode, however, the offset/gain cannot be adjusted.
- *2. The offset and the gain should satisfy the following condition:
 $1V \leq (\text{Gain} - \text{Offset})$
- *3. The offset and the gain should satisfy the following condition:
 $3mA \leq (\text{Gain} - \text{Offset}) \leq 30mA$
- *4. The resolution and the input/output characteristics depend on the selected mode.
- *5. If 1 or more channels use the digital filter(s), the time required for A/D conversion will be "5 ms × number of selected channels."

4.1.6 FX2NC-4AD

Specifications	FX2NC-4AD	
	Voltage input	Current input
Number of input points	4ch	
Analog input range	-10V to +10V DC (Input resistance: 200kΩ)	-20mA to +20mA DC 4mA to 20mA DC (Input resistance: 250 Ω)
Absolute maximum input	±15V	±30mA
Offset	-10V to +9V ^{*1,*2}	-20mA to +17mA ^{*1,*3}
Gain	-9V to +10V ^{*1,*2}	-17mA to +30mA ^{*1,*3}
Digital output	With sign, 16 bits, binary	With sign, 15 bits, binary
Resolution ^{*4}	0.32mV(20V×1/64000) 2.5mV(20V×1/8000)	1.25μA(40mA×1/32000) 5.00μA(40mA×1/8000)
Overall accuracy	Ambient temperature: 25±5°C	±0.3%(±60mV) for 20V full scale Same accuracy for 4mA to 20mA input
	Ambient temperature: 0 to 55°C	±0.5%(±100mV) for 20V full scale Same accuracy for 4mA to 20mA input
Time required for A/D conversion	1ms × number of selected channels ^{*5}	
Input characteristics ^{*4}	<p>●When the input mode is set to "0":</p>	<p>●When the input mode is set to "6":</p> <p>●When the input mode is set to "3":</p>
Insulation method	<ul style="list-style-type: none"> The photocoupler is used to insulate the analog input area from the PLC. The DC/DC converter is used to insulate the power supply from the analog inputs. Channels are not insulated from each other. 	
Number of I/O points occupied	8 points (Taken from either the input or output points of the PLC.)	

- *1. Adjustment of the offset or gain value will not affect the resolution. In the direct indication mode, however, the offset/gain cannot be adjusted.
- *2. The offset and the gain should satisfy the following condition:
 $1V \leq (\text{Gain} - \text{Offset})$
- *3. The offset and the gain should satisfy the following condition:
 $3mA \leq (\text{Gain} - \text{Offset}) \leq 30mA$
- *4. The resolution and the input/output characteristics depend on the selected mode.
- *5. If 1 or more channels use the digital filter(s), the time required for A/D conversion will be "5 ms × number of selected channels."

A	Common Items
B	FX3U-4AD FX3UC-4AD
C	FX3U-4AD-ADP
D	FX3G-2AD-BD
E	FX3U-4DA
F	FX3U-4DA-ADP
G	FX3G-1DA-BD
H	FX3U-3A-ADP
I	FX3U-4AD-PT -ADP
J	FX3U-4AD-PTW -ADP

4.1.7 FX2N-8AD

Specifications		FX2N-8AD	
		Voltage input	Current input
Number of input points		8ch	
Analog input range		-10V to +10V DC (Input resistance: 200 kΩ)	-20mA to +20mA DC 4mA to 20mA DC (Input resistance: 250 Ω)
Absolute maximum input		±15V	±30mA
Offset		-10V to +9V ^{*1,*2}	-20mA to +17mA ^{*1,*3}
Gain		-9V to +10V ^{*1,*2}	-17mA to +30mA ^{*1,*3}
Digital output		With sign, 15 bits, binary	With sign, 14 bits, binary
Resolution ^{*4}		0.63mV(20V×1/32000) 2.5mV(20V×1/8000)	2.50μA(40mA×1/16000) 2.00μA(16mA×1/8000)
Overall accuracy	Ambient temperature: 25±5°C	±0.3%(±60mV) for 20V full scale	±0.3%(±120μA) for 40mA full scale Same accuracy for 4mA to 20mA input
	Ambient temperature: 0 to 55°C	±0.5%(±100mV) for 20V full scale	±0.5%(±200μA) for 40mA full scale Same accuracy for 4mA to 20mA input
Time required for A/D conversion		500μs × number of selected channels ^{*5}	
Input characteristics ^{*4}		<p>●When the input mode is set to "0":</p>	<p>●When the input mode is set to "6":</p> <p>●When the input mode is set to "3":</p>
Insulation method		<ul style="list-style-type: none"> The photocoupler is used to insulate the analog input area from the PLC. The DC/DC converter is used to insulate the power supply from the analog inputs. Channels are not insulated from each other. 	
Number of I/O points occupied		8 points (Taken from either the input or output points of the PLC.)	

- *1. Adjustment of the offset or gain value will not affect the resolution. In the direct indication mode, however, the offset/gain cannot be adjusted.
- *2. The offset and the gain should satisfy the following condition:
 $1V \leq (\text{Gain} - \text{Offset})$
- *3. The offset and the gain should satisfy the following condition:
 $3mA \leq (\text{Gain} - \text{Offset}) \leq 30mA$
- *4. The resolution and the input/output characteristics depend on the selected mode.
- *5. If 1 or more channels use the thermocouple input(s), the input voltage/current data conversion speed will be "1 ms × number of selected channels."

4.1.8 FX3G-2AD-BD

Specifications	FX3G-2AD-BD		
	Voltage input	Current input	
Number of input points	2ch		
Analog input range	0V to 10V DC (Input resistance: 198.7 kΩ)	4mA to 20mA DC (Input resistance: 250 Ω)	
Absolute maximum input	-0.5V, +15V	-2mA, +30mA	
Offset	Impossible to change		
Gain	Impossible to change		
Digital output	12 bits, binary	11 bits, binary	
Resolution	2.5mV(10V×1/4000)	8μA(16mA×1/2000)	
Overall accuracy	Ambient temperature: 25±5°C	±0.5%(±50mV) for 10V full scale	±0.5%(±80μA) for 16mA full scale
	Ambient temperature: 0 to 55°C	±1.0%(±100mV) for 10V full scale	±1.0%(±160μA) for 16mA full scale
Time required for A/D conversion	180μs (Data updated every scan time.)		
Input characteristics			
Insulation method	<ul style="list-style-type: none"> The analog input area is not insulated from the PLC. Channels are not insulated from each other. 		
Number of I/O points occupied	0 point (This number is not related to the maximum I/O points of the PLC.)		

A	Common Items
B	FX3U-4AD FX3UC-4AD
C	FX3U-4AD-ADP
D	FX3G-2AD-BD
E	FX3U-4DA
F	FX3U-4DA-ADP
G	FX3G-1DA-BD
H	FX3U-3A-ADP
I	FX3U-4AD-PT -ADP
J	FX3U-4AD-PTW -ADP

4.2 Analog Output

4.2.1 FX3U-4DA-ADP

Specifications	FX3U-4DA-ADP		
	Voltage output	Current output	
Number of output points	4ch		
Analog output range	0V to 10V DC (External load: 5k to 1MΩ)	4mA to 20mA DC (External load: 500Ω or less)	
Offset	Impossible to change		
Gain	Impossible to change		
Digital input	12 bits, binary		
Resolution	2.5mV(10V×1/4000)	4μA(16mA×1/4000)	
Overall accuracy	Ambient temperature: 25±5°C	±0.5%(±50mV) for 10V full scale	±0.5%(±80μA) for 16mA full scale
	Ambient temperature: 0 to 55°C	±1.0%(±100mV) for 10V full scale	±1.0%(±160μA) for 16mA full scale
	Reference	If the external load resistance (Rs) is less than 5kΩ, the accuracy increases as shown in the following formula: (Increase: 100 mV per 1%) $\frac{47 \times 100}{R_s + 47} - 0.9(\%)$	
Time required for D/A conversion	<ul style="list-style-type: none"> FX3U/FX3UC Series PLC : 200μs (Data updated every scan time.) FX3G Series PLC : 250μs (Data updated every scan time.) 		
Output characteristics			
Insulation method	<ul style="list-style-type: none"> The photocoupler is used to insulate the analog output area from the PLC. The DC/DC converter is used to insulate the power supply from the analog inputs. Channels are not insulated from each other. 		
Number of I/O points occupied	0 point (This number is not related to the maximum I/O points of the PLC.)		

4.2.2 FX2N-2DA

Specifications	FX2N-2DA	
	Voltage output	Current output
Number of output points	2ch	
Analog output range	0V to 10V DC 0V to 5V DC (External load: 2k to 1MΩ)	4mA to 20mA DC (External load: 400Ω or less)
Offset*1,*2	If the digital value is "0": 0V to 1V	If the digital value is "0": 4mA
Gain*1,*2	If the digital value is "4000": 5V to 10V	If the digital value is "4000": 20mA
Digital output	12 bits, binary	
Resolution	$2.5\text{mV}(10\text{V} \times 1/4000)^{*2}$	$4\mu\text{A}(16\text{mA} \times 1/4000)^{*2}$
Overall accuracy	$\pm 0.1\text{V}$	$\pm 0.16\text{mA}$
	Does not include any load fluctuation.	-
Time required for D/A conversion	4ms × number of selected channels (Operation synchronized with sequence program)	
Output characteristics		
	If the input data consists of 13 bits or more, only the lower 12 bits will be valid, and the other bits will be ignored.	
Insulation method	<ul style="list-style-type: none"> The photocoupler is used to insulate the analog output area from the PLC. Channels are not insulated from each other. 	
Number of I/O points occupied	8 points (Taken from either the input or output points of the PLC.)	

*1. Use the adjustment volume to adjust the FX2N-2DA.

*2. Adjustment of the offset or gain value will change the resolution.

A	Common Items
B	FX3U-4AD FX3UC-4AD
C	FX3U-4AD-ADP
D	FX3G-2AD-BD
E	FX3U-4DA
F	FX3U-4DA-ADP
G	FX3G-1DA-BD
H	FX3U-3A-ADP
I	FX3U-4AD-PT -ADP
J	FX3U-4AD-PTW -ADP

4.2.3 FX3U-4DA

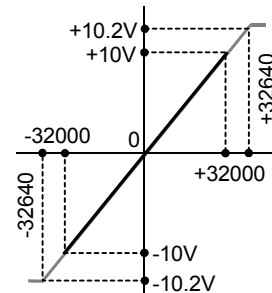
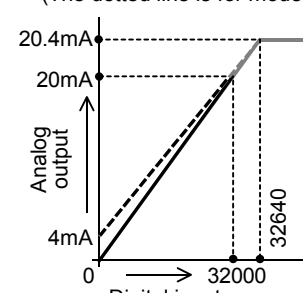
Specifications		FX3U-4DA	
		Voltage output	Current output
Number of output points		4ch	
Analog output range		-10V to +10V DC (External load: 1k to 1MΩ)	0mA to 20mA DC 4mA to 20mA DC (External load: 500Ω or less)
Offset		-10V to +9V ^{*1,*2}	0mA to 17mA ^{*1,*3}
Gain		-9V to +10V ^{*1,*2}	3mA to 30mA ^{*1,*3}
Digital input		With sign, 16 bits, binary	15 bits, binary
Resolution		0.32mV(20V×1/64000) ^{*4}	0.63μA(20mA×1/32000) ^{*4}
Overall accuracy	Ambient temperature: 25±5°C	±0.3%(±60mV) for 20V full scale	±0.3%(±60μA) for 20mA full scale Same accuracy for 4mA to 20mA output
	Ambient temperature: 0 to 55°C	±0.5%(±100mV) for 20V full scale	±0.5%(±100μA) for 20mA full scale Same accuracy for 4mA to 20mA output
	Reference	Includes corrective function by load fluctuation.	-
Time required for D/A conversion		1ms (The number of selected channels will not affect this value.)	
Output characteristics		<p>●When the output mode is set to "0":</p> 	<p>●When the output mode is "2": (The dotted line is for mode 3.)</p> 
Insulation method		<ul style="list-style-type: none"> The photocoupler is used to insulate the analog output area from the PLC. The DC/DC converter is used to insulate the power supply from the analog output. Channels are not insulated from each other. 	
Number of I/O points occupied		8 points (Taken from either the input or output points of the PLC.)	

- *1. Adjustment of the offset or gain value will not affect the resolution. In the analog value specification mode, however, the offset/gain cannot be adjusted.
- *2. The offset and the gain should satisfy the following condition:
 $1V \leq (\text{Gain} - \text{Offset}) \leq 10V$
- *3. The offset and the gain should satisfy the following condition:
 $3mA \leq (\text{Gain} - \text{Offset}) \leq 30mA$
- *4. Adjustment of the offset or gain value will not affect the resolution.

4.2.4 FX2N-4DA

Specifications	FX2N-4DA	
	Voltage output	Current output
Number of output points	4ch	
Analog output range	-10V to +10V DC (External load: 2k to 1MΩ)	0mA to 20mA DC 4mA to 20mA DC (External load: 500Ω or less)
Offset	-5V to +5V ^{*1,*2}	-20mA to +20mA ^{*1,*3}
Gain	15 V or less, and Gain - Offset ≥ 1V	32 mA or less, and Gain - Offset ≥ 4mA
Digital output	With sign, 12 bits, binary	10 bits, binary
Resolution	5mV(10V×1/2000) ^{*1}	20μA(20mA×1/1000) ^{*1}
Overall accuracy	±1.0%(±200mV) for 20V full scale	±1.0%(±200μA) for 20mA full scale Same accuracy for 4mA to 20mA output
	Does not include any load fluctuation.	-
Time required for D/A conversion	2.1 ms (The number of selected channels will not affect this value.)	
Output characteristics	<p>●When the output mode is set to "0":</p>	<p>●When the output mode is set to "2": (The dotted line is for mode 1.)</p>
Insulation method	<ul style="list-style-type: none"> The photocoupler is used to insulate the analog input area from the PLC. The DC/DC converter is used to insulate the power supply from the analog output. Channels are not insulated from each other. 	
Number of I/O points occupied	8 points (Taken from either the input or output points of the PLC.)	

- *1. Adjustment of the offset or gain value will not affect the resolution.
- *2. The offset and the gain should satisfy the following condition: $1V \leq (\text{Gain} - \text{Offset}) \leq 15V$
- *3. The offset and the gain should satisfy the following condition: $4mA \leq (\text{Gain} - \text{Offset}) \leq 32mA$

A	Common Items
B	FX3U-4AD FX3UC-4AD
C	FX3U-4AD-ADP
D	FX3G-2AD-BD
E	FX3U-4DA
F	FX3U-4DA-ADP
G	FX3G-1DA-BD
H	FX3U-3A-ADP
I	FX3U-4AD-PT -ADP
J	FX3U-4AD-PTW -ADP

4.2.5 FX2NC-4DA

Specifications		FX2NC-4DA	
		Voltage output	Current output
Number of output points		4ch	
Analog output range		-10V to +10V DC (External load: 2k to 1MΩ)	0mA to 20mA DC 4mA to 20mA DC (External load: 500Ω or less)
Offset		-5V to +5V ^{*1,*2}	-20mA to +20mA ^{*1,*3}
Gain		-4V to +15V ^{*1,*2}	-16mA to +32mA ^{*1,*3}
Digital input		With sign, 12 bits, binary	10 bits, binary
Resolution ^{*1}		5mV(20V×1/4000)	20μA(20mA×1/1000)
Overall accuracy	Ambient temperature: 25±5°C	±0.5%(±100mV) for 20V full scale	±0.5%(±100μA) for 20mA full scale Same accuracy for 4mA to 20mA output
	Ambient temperature: 0 to 55°C	±1.0%(±200mV) for 20V full scale	±1.0%(±200μA) for 20mA full scale Same accuracy for 4mA to 20mA output
	Reference	Does not include any load fluctuation.	-
Time required for D/A conversion		2.1ms (The number of selected channels will not affect this value.)	
Output characteristics		<p>●When the output mode is set to "0":</p>	<p>●When the output mode is "2": (The dotted line is for mode 1.)</p>
Insulation method		<ul style="list-style-type: none"> The photocoupler is used to insulate the analog output area from the PLC. The DC/DC converter is used to insulate the power supply from the analog output. Channels are not insulated from each other. 	
Number of I/O points occupied		8 points (Taken from either the input or output points of the PLC.)	

*1. Adjustment of the offset or gain value will not affect the resolution.

*2. The offset and the gain should satisfy the following condition:
1V ≤ (Gain - Offset) ≤ 15V

*3. The offset and the gain should satisfy the following condition:
4mA ≤ (Gain - Offset) ≤ 32mA

4.2.6 FX3G-1DA-BD

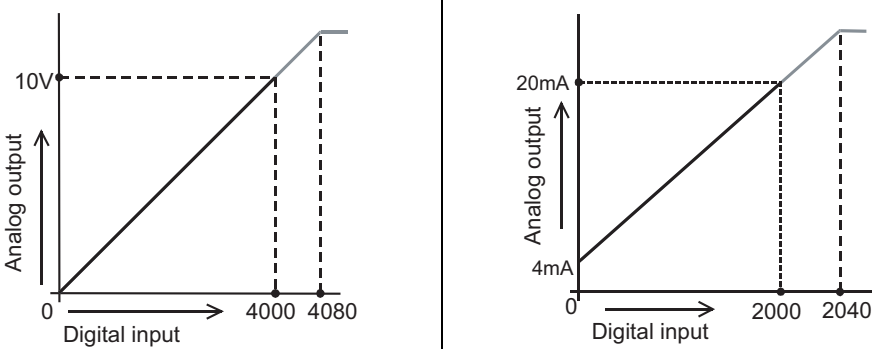
Specifications	FX3G-1DA-BD		
	Voltage output	Current output	
Number of output points	1ch		
Analog output range	0V to 10V DC (External load: 2k to 1M Ω)	4mA to 20mA DC (External load: 500 Ω or less)	
Offset	Impossible to change		
Gain	Impossible to change		
Digital input	12 bits, binary	11 bits, binary	
Resolution	2.5mV(10V \times 1/4000)	8 μ A(16mA \times 1/2000)	
Overall accuracy	Ambient temperature: 25 \pm 5 $^{\circ}$ C	\pm 0.5%(\pm 50mV) for 10V full scale	\pm 0.5%(\pm 80 μ A) for 16mA full scale
	Ambient temperature: 0 to 55 $^{\circ}$ C	\pm 1.0%(\pm 100mV) for 10V full scale	\pm 1.0%(\pm 160 μ A) for 16mA full scale
	Reference	Shipment adjustment is carried out by external load resistance 2k Ω . If external load resistance becomes larger than 2k Ω , the output voltage will increase slightly. When the load is 1M Ω , the output voltage is about 2% higher than the correct value.	
Time required for D/A conversion	60 μ s (Data updated every scan time.)		
Output characteristics	 <p>Caution: An area of dead band is located in the region of 0V. Therefore the output analog value may not represent the digital value accurately.</p>		
Insulation method	• The analog output area is not insulated from the PLC.		
Number of I/O points occupied	0 point (This number is not related to the maximum I/O points of the PLC.)		

A	Common Items
B	FX3U-4AD FX3UC-4AD
C	FX3U-4AD-ADP
D	FX3G-2AD-BD
E	FX3U-4DA
F	FX3U-4DA-ADP
G	FX3G-1DA-BD
H	FX3U-3A-ADP
I	FX3U-4AD-PT -ADP
J	FX3U-4AD-PTW -ADP

4.3 Mixed Analog Input/Output

4.3.1 FX3U-3A-ADP

Specifications	FX3U-3A-ADP				
	Voltage input	Current input	Voltage output	Current output	
Number of input/output points	2ch		1ch		
Analog input/output range	0V to 10V DC (Input resistance:198.7kΩ)	4mA to 20mA DC (Input resistance:250Ω)	0V to 10V DC (External load:5k to 1MΩ)	4mA to 20mA DC (External load:500Ω or less)	
Absolute maximum input	-0.5V, +15V	-2mA, +30mA	-	-	
Digital input/output	12 bits, binary				
Resolution	2.5mV(10V×1/4000)	5μA(16mA×1/3200)	2.5mV(10V×1/4000)	4μA(16mA×1/4000)	
Overall accuracy	Ambient temperature: 25±5°C	±0.5%(±50mV) for 10V full scale	±0.5%(±80μA) for 16mA full scale	±0.5%(±50mV) for 10V full scale	±0.5%(±80μA) for 16mA full scale
	Ambient temperature: 0 to 55°C	±1.0%(±100mV) for 10V full scale	±1.0%(±160μA) for 16mA full scale	±1.0%(±100mV) for 10V full scale	±1.0%(±160μA) for 16mA full scale
	Reference	-	-	If the external load resistance (Rs) is less than 5kΩ, the accuracy increases as shown in the following formula: (Increase: 100 mV per 1%) $\frac{47 \times 100}{R_s + 47} - 0.9(\%)$	-
Time required for conversion	<ul style="list-style-type: none"> FX3U/FX3UC Series PLC : 80μs for each selected input channel + 40μs for each selected output channel (Operation synchronized with sequence program) FX3G Series PLC : 90μs for each selected input channel + 50μs for each selected output channel (Operation synchronized with sequence program) 				
I/O characteristics					
Insulation method	<ul style="list-style-type: none"> The photocoupler is used to insulate the analog input and output area from the PLC. The DC/DC converter is used to insulate the power supply from the analog input and output. Channels are not insulated from each other. 				
Number of I/O points occupied	0 points (This number of points is not related to the maximum number of input/output points of the PLC.)				

4.3.2 FX2N-5A

1. Analog input

Specifications		FX2N-5A	
		Voltage input	Current input
Number of input points		4ch	
Analog input range		-10V to +10V DC -100mV to +100mV DC (Input resistance: 200kΩ)	-20mA to +20mA DC 4mA to 20mA DC (Input resistance: 250Ω)
Absolute maximum input		±15V	
Offset		<ul style="list-style-type: none"> -10V to +10V DC: -32V to +5V DC -100mV to +100mV DC: -320mV to +50mV DC 	-32mA to +10mA
Gain		<ul style="list-style-type: none"> -10V to +10V DC: -5V to +32V, and Gain - Offset > 1V -100mV to +100mV DC: -50mV to +320mV, and Gain - Offset > 10mA 	-10mA to +32mA, and Gain - Offset > 1 mA
Digital input/output		<ul style="list-style-type: none"> -10V to +10V DC: With sign, 16 bits, binary -100mV to +100mV DC: With sign, 12 bits, binary 	With sign, 15 bits, binary
Resolution		312.5μV(20V×1/64000) 50μV(200mV×1/4000)	1.25μA(40mA×1/32000) 10μA(40mA×1/4000)
Overall accuracy	Ambient temperature: 25±5°C	<ul style="list-style-type: none"> -10V to +10V DC: ±0.3% (±60mV) for 20V full scale -100mV to +100mV DC: ±0.5% (±1mV) for 200mV full scale 	±0.3%(±120μA) for 40mA full scale Same accuracy for 4mA to 20mA input
	Ambient temperature: 0±55°C	<ul style="list-style-type: none"> -10V to +10V DC: ±0.5% (±100mV) for 20V full scale -100mV to +100mV DC: ±1.0% (±2mV) for 200mV full scale 	±0.5%(±200μA) for 40mA full scale Same accuracy for 4mA to 20mA input
Time required for conversion		1ms × number of selected channels	
I/O characteristics		<p>●When the input mode is set to "0":</p>	<p>●When the input mode is set to "2":</p> <p>●When the input mode is set to "1":</p>

A	Common Items
B	FX3U-4AD FX3UC-4AD
C	FX3U-4AD-ADP
D	FX3G-2AD-BD
E	FX3U-4DA
F	FX3U-4DA-ADP
G	FX3G-1DA-BD
H	FX3U-3A-ADP
I	FX3U-4AD-PT -ADP
J	FX3U-4AD-PTW -ADP

2. Analog output

Specifications	FX2N-5A	
	Voltage output	Current output
Number of output points	1ch	
Analog output range	-10V to +10V DC (External load: 5k to 1MΩ)	0mA to 20mA DC 4mA to 20mA DC (External load: 500Ω or less)
Offset	-10V to +5V	0mA to 10mA
Gain	-9V to +10V, and Gain - Offset ≥ 1V	3 mA to 30 mA or less, and Gain - Offset ≥ 3mA
Digital input/output	With sign, 12 bits, binary	10 bits, binary
Resolution	5mV(10V×1/4000)	20μA(20mA×1/1000)
Overall accuracy	Ambient temperature: 25±5°C	±0.5% (±100mV) for 20V full scale Same accuracy for 4mA to 20mA output
	Ambient temperature: 0±55°C	±1.0% (±200mV) for 20V full scale Same accuracy for 4mA to 20mA output
Time required for conversion	2ms	
I/O characteristics	<p>●When the output mode is set to "0":</p>	<p>●When the output mode is "4": (The dotted line is for mode 2.)</p>

3. Other

Specifications	FX2N-5A
Insulation method	<ul style="list-style-type: none"> The photocoupler is used to insulate the analog input and output area from the PLC. The DC/DC converter is used to insulate the power supply from the analog input and output. Channels are not insulated from each other.
Number of I/O points occupied	8 points (Taken from either the input or output points of the PLC.)

4.3.3 FX0N-3A

Specifications	FX0N-3A			
	Voltage input	Current input	Voltage output	Current output
Number of input/output points	2ch		1ch	
Analog input/output range*1	0V to 10V DC 0V to 5V DC (Input resistance: 200kΩ)	4mA to 20mA DC (Input resistance: 250Ω)	0V to 10V DC 0V to 5V DC (External load: 1k to 1MΩ)	4mA to 20mA DC (External load: 500Ω)
Absolute maximum input	-0.5V, +15V	-2mA, +60mA	-	-
Offset*2*3	If the digital value is "0": 0V to 1V	If the digital value is "0": 0mA to 4mA	If the digital value is "0": 0V to 1V	If the digital value is "0": 4mA
Gain*2*3	If the digital value is "250": 5V to 10V	If the digital value is "250": 20mA	If the digital value is "250": 5V to 10V	If the digital value is "250": 20mA
Digital input/output	0 to 250 8 bits, binary		0 to 250 8 bits, binary	
Resolution*3	40mV(10V×1/250)	64μA(16mA×1/250)	40mV(10V×1/250)	64μA(16mA×1/250)
Overall accuracy	±0.1V	±0.16mA	±0.1V	±0.16mA
Time required for conversion	TO instruction processing time × 2 + FROM instruction processing time (operation synchronized with sequence program)			
I/O characteristics				
	If the input data consists of 9 bits or more, only the lower 8 bits will be valid, and the other bits will be ignored.			
Insulation method	<ul style="list-style-type: none"> The photocoupler is used to insulate the analog input and output area from the PLC. Channels are not insulated from each other. 			
Number of I/O points occupied	8 points (Taken from either the input or output points of the PLC.)			

- *1. Combined use of voltage and current inputs is not possible.
- *2. Adjustment of the volume (offset or gain) value will change the resolution.
- *3. Adjustment of the offset or gain value will change the resolution.

4.4 Temperature Sensor Input

4.4.1 FX3U-4AD-PT-ADP

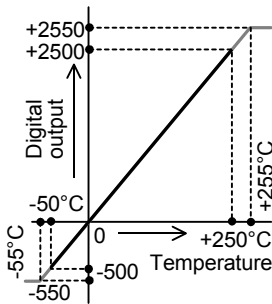
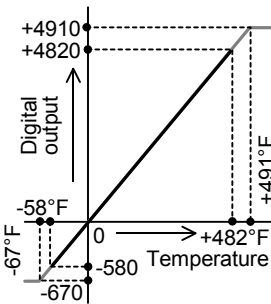
Specifications	FX3U-4AD-PT-ADP	
	Centigrade(°C)	Fahrenheit(°F)
Number of input points	4ch	
Input signal	3-wire platinum resistance thermometer sensor(s) JIS C 1604-1997	
Rated temperature range	-50°C to +250°C	-58°F to +482°F
Digital output	-500 to +2500	-580 to +4820
Resolution	0.1°C	0.18°F
Overall accuracy	<ul style="list-style-type: none"> Ambient temperature: 25°C±5°C ±0.5% for full scale Ambient temperature: 0°C to 55°C ±1.0% for full scale 	
Time required for conversion	<ul style="list-style-type: none"> FX3U/FX3UC Series PLC : 200μs (Data updated every scan time.) FX3G Series PLC : 250μs (Data updated every scan time.) 	
Input characteristics		
Insulation method	<ul style="list-style-type: none"> The photocoupler is used to insulate the analog input area from the PLC. The DC/DC converter is used to insulate the power supply from the analog inputs. Channels are not insulated from each other. 	
Number of I/O points occupied	0 points (This number of points is not related to the maximum number of input/output points of the PLC.)	

4.4.2 FX3U-4AD-PTW-ADP

Specifications	FX3U-4AD-PTW-ADP	
	Centigrade(°C)	Fahrenheit(°F)
Number of input points	4ch	
Input signal	3-wire platinum resistance thermometer sensor(s) JIS C 1604-1997	
Rated temperature range	-100°C to +600°C	-148°F to +1112°F
Digital output	-1000 to +6000	-1480 to +11120
Resolution	0.2°C to 0.3°C	0.4°F to 0.5°F
Overall accuracy	<ul style="list-style-type: none"> Ambient temperature: 25°C±5°C ±0.5% for full scale Ambient temperature: 0°C to 55°C ±1.0% for full scale 	
Time required for conversion	<ul style="list-style-type: none"> FX3U/FX3UC Series PLC : 200μs (Data updated every scan time.) FX3G Series PLC : 250μs (Data updated every scan time.) 	
Input characteristics		
Insulation method	<ul style="list-style-type: none"> The photocoupler is used to insulate the analog input area from the PLC. The DC/DC converter is used to insulate the power supply from the analog inputs. Channels are not insulated from each other. 	
Number of I/O points occupied	0 points (This number of points is not related to the maximum number of input/output points of the PLC.)	

A	Common Items
B	FX3U-4AD FX3UC-4AD
C	FX3U-4AD-ADP
D	FX3G-2AD-BD
E	FX3U-4DA
F	FX3U-4DA-ADP
G	FX3G-1DA-BD
H	FX3U-3A-ADP
I	FX3U-4AD-PT -ADP
J	FX3U-4AD-PTW -ADP

4.4.3 FX3U-4AD-PNK-ADP

Specifications	FX3U-4AD-PNK-ADP			
	Centigrade(°C)		Fahrenheit(°F)	
Number of input points	4ch			
Input signal	Platinum resistance thermometer sensor (2-wire or 3-wire) Pt1000 JIS C 1604-1997 Nickel resistance thermometer sensor (2-wire or 3-wire) Ni1000 DIN 43760-1987			
Rated temperature range	Pt1000	-50°C to +250°C	Pt1000	-58°F to +482°F
	Ni1000	-40°C to +110°C	Ni1000	-40°F to +230°F
Digital output	Pt1000	-500 to +2500	Pt1000	-580 to +4820
	Ni1000	-400 to +1100	Ni1000	-400 to +2300
Resolution	Pt1000	0.1°C	Pt1000	0.2°F
	Ni1000		Ni1000	
Overall accuracy	<ul style="list-style-type: none"> Ambient temperature : 25°C±5°C ±0.5% for full scale Ambient temperature : 0°C to 55°C ±1.0% for full scale 			
Time required for conversion	<ul style="list-style-type: none"> FX3U/FX3UC Series PLC : 200µs (Data updated every scan time.) FX3G Series PLC : 250µs (Data updated every scan time.) 			
Input characteristics				
Insulation method	<ul style="list-style-type: none"> The photocoupler is used to insulate the analog input area from the PLC. The DC/DC converter is used to insulate the power supply line from the analog input area. Channels are not insulated from each other. 			
Number of I/O points occupied	0 points (This number of points is not related to the maximum number of input/output points of the PLC.)			

4.4.4 FX3U-4AD-TC-ADP

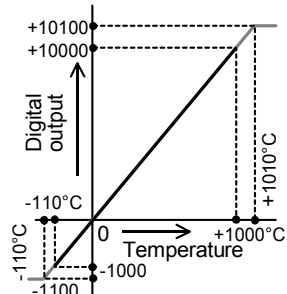
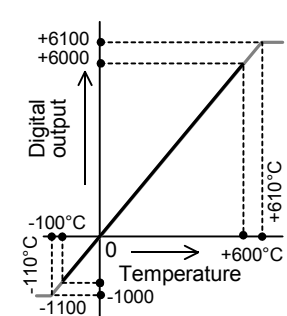
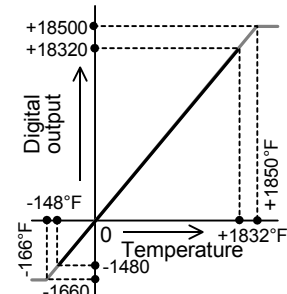
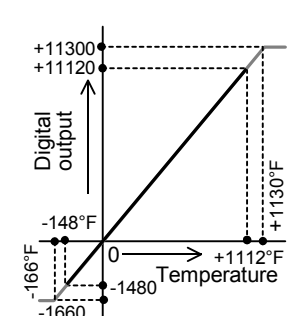
Specifications	FX3U-4AD-TC-ADP	
	Centigrade(°C)	Fahrenheit(°F)
Number of input points	4ch	
Input signal	Thermocouple type K or J JIS C 1602-1995	
Rated temperature range	<ul style="list-style-type: none"> Type K: -100°C to +1000°C Type J: -100°C to +600°C 	<ul style="list-style-type: none"> Type K: -148°F to +1832°F Type J: -148°F to +1112°F
Digital output	<ul style="list-style-type: none"> Type K: -1000 to +10000 Type J: -1000 to +6000 	<ul style="list-style-type: none"> Type K: -1480 to +18320 Type J: -1480 to +11120
Resolution	<ul style="list-style-type: none"> Type K: 0.4°C Type J: 0.3°C 	<ul style="list-style-type: none"> Type K: 0.72°F Type J: 0.54°F
Overall accuracy	±(0.5% for full scale +1°C)	
Time required for conversion	<ul style="list-style-type: none"> FX3U/FX3UC Series PLC : 200μs (Data updated every scan time.) FX3G Series PLC : 250μs (Data updated every scan time.) 	
Input characteristics	<ul style="list-style-type: none"> Type K  <ul style="list-style-type: none"> Type J 	<ul style="list-style-type: none"> Type K  <ul style="list-style-type: none"> Type J 
Insulation method	<ul style="list-style-type: none"> The photocoupler is used to insulate the analog input area from the PLC. The DC/DC converter is used to insulate the power supply from the analog inputs. Channels are not insulated from each other. 	
Number of I/O points occupied	0 points (This number of points is not related to the maximum number of input/output points of the PLC.)	

A	Common Items
B	FX3U-4AD FX3UC-4AD
C	FX3U-4AD-ADP
D	FX3G-2AD-BD
E	FX3U-4DA
F	FX3U-4DA-ADP
G	FX3G-1DA-BD
H	FX3U-3A-ADP
I	FX3U-4AD-PT -ADP
J	FX3U-4AD-PTW -ADP

4.4.5 FX2N-4AD-PT

Specifications	FX2N-4AD-PT	
	Centigrade(°C)	Fahrenheit(°F)
Number of input points	4ch	
Input signal	3-wire platinum resistance thermometer sensor(s) DIN43760 Pt100 JIS C 1604-1997 JPt100 JIS C 1604-1981	
Input signal current	1mA(Constant current system)	
Rated temperature range	-100°C to +600°C	-148°F to +1112°F
Digital output	-1000 to +6000	-1480 to +11120
Resolution	0.2°C to 0.3°C	0.36°F to 0.54°F
Overall accuracy	±1.0% for full scale	
Time required for conversion	60ms(15ms×4ch)	
Input characteristics		
Insulation method	<ul style="list-style-type: none"> • The photocoupler is used to insulate the analog input area from the PLC. • The DC/DC converter is used to insulate the power supply from the analog inputs. • Channels are not insulated from each other. 	
Number of I/O points occupied	8 points (Count either the input or output points of the PLC.)	

4.4.6 FX2N-4AD-TC

Specifications	FX2N-4AD-TC	
	Centigrade(°C)	Fahrenheit(°F)
Number of input points	4ch	
Input signal	Thermocouple type K or J JIS C 1602-1995	
Rated temperature range	<ul style="list-style-type: none"> Type K: -100°C to +1200°C Type J: -100°C to +600°C 	<ul style="list-style-type: none"> Type K: -148°F to +2192°F Type J: -148°F to +1112°F
Digital output	<ul style="list-style-type: none"> Type K: -1000 to +12000 Type J: -1000 to +6000 	<ul style="list-style-type: none"> Type K: -1480 to +21920 Type J: -1480 to +11120
Resolution	<ul style="list-style-type: none"> Type K: 0.4°C Type J: 0.3°C 	<ul style="list-style-type: none"> Type K: 0.72°F Type J: 0.54°F
Overall accuracy	±(0.5% for full scale +1°C)	
Time required for conversion	(240ms±2%)× number of selected channels	
Input characteristics		
Insulation method	<ul style="list-style-type: none"> The photocoupler is used to insulate the analog input area from the PLC. The DC/DC converter is used to insulate the power supply from the analog inputs. Channels are not insulated from each other. 	
Number of I/O points occupied	8 points (Taken from either the input or output points of the PLC.)	

A	Common Items
B	FX3U-4AD FX3UC-4AD
C	FX3U-4AD-ADP
D	FX3G-2AD-BD
E	FX3U-4DA
F	FX3U-4DA-ADP
G	FX3G-1DA-BD
H	FX3U-3A-ADP
I	FX3U-4AD-PT -ADP
J	FX3U-4AD-PTW -ADP

4.4.7 FX2N-8AD

Specifications	FX2N-8AD	
	Centigrade(°C)	Fahrenheit(°F)
Number of input points	8ch	
Input signal	Thermocouple type K, J, and T JIS C 1602-1995	
Rated temperature range	<ul style="list-style-type: none"> Type K -100°C to +1200°C Type J -100°C to +600°C Type T -100°C to +350°C 	<ul style="list-style-type: none"> Type K -148°F to +2192°F Type J -148°F to +1112°F Type T -148°F to +662°F
Digital output	<ul style="list-style-type: none"> Type K -1000 to +12000 Type J -1000 to +6000 Type T -1000 to +3500 	<ul style="list-style-type: none"> Type K -1480 to +21920 Type J -1480 to +11120 Type T -1480 to +6620
Resolution	0.1°C	0.1°F
Overall accuracy Ambient temperature: 0 to 55°C	<ul style="list-style-type: none"> Type K: ±0.5%(±6.5°C) for full scale Type J: ±0.5%(±3.5°C) for full scale Type T: ±0.7%(±3.15°C) for full scale 	<ul style="list-style-type: none"> Type K: ±0.5%(±11.7°F) for full scale Type J: ±0.5%(±6.3°F) for full scale Type T: ±0.7%(±5.67°F) for full scale
Time required for conversion	40ms × number of selected channels	
Input characteristics		
Insulation method	<ul style="list-style-type: none"> The photocoupler is used to insulate the analog input area from the PLC. The DC/DC converter is used to insulate the power supply from the analog inputs. Channels are not insulated from each other. 	
Number of I/O points occupied	8 points (Taken from either the input or output points of the PLC.)	

4.4.8 FX2N-2LC

Specifications	FX2N-2LC*1*2	
	Centigrade(°C)	Fahrenheit(°F)
Number of input points	2ch	
Input signal	Thermocouple type K, J, R, S, E, T, B, N, PL II, W5Re/W26Re, U, and L JIS C 1602-1995 3-wire platinum resistance thermometer sensor(s) Pt100 JIS C 1604-1997, JPt100 JIS C 1604-1981	
Rated temperature range	Examples: • Type K -100°C to +1300°C • Type J -100.0°C to +800.0°C	Examples: • Type K -100°F to +2400°F • Type J -100°F to +2100°F
Digital output	Examples: • Type K -100 to +1300 • Type J -1000 to +8000	Examples: • Type K -100 to +2400 • Type J -100 to +2100
Resolution	1°C or 0.1°C	1°F or 0.1°F
Overall accuracy	Ambient temperature: 23±5°C	±0.3°C(±1digit) for full scale
	Ambient temperature: 0 to 55°C	±0.7°C (±1digit) for full scale
Cold junction temperature compensation error	±1.0°C ±2.0°C if the input value is in the range from -150°C to -100°C ±3.0°C if the input value is in the range from -200°C to -150°C	
Time required for conversion	500ms(Sampling period)	
Input characteristics	<p>●When type K (input mode 2) is set:</p>	<p>●When type K (input mode 4) is set:</p>
Insulation method	<ul style="list-style-type: none"> The photocoupler is used to insulate the analog input area from the PLC. The DC/DC converter is used to insulate the power supply from the analog inputs. Channels are insulated from each other. 	
Number of I/O points occupied	8 points (Taken from either the input or output points of the PLC.)	

- *1. For FX2N-2LC, the rated temperature range, digital output value, and resolution depend on the selected sensor and mode.
- *2. Accuracy is not guaranteed for the temperature range of 0°C to 399°C(0°F to 799°F) of the thermocouple -B input and for the temperature range of 0°F to 32°F of the PL II and WRe5-26 inputs.

A	Common Items
B	FX3U-4AD FX3UC-4AD
C	FX3U-4AD-ADP
D	FX3G-2AD-BD
E	FX3U-4DA
F	FX3U-4DA-ADP
G	FX3G-1DA-BD
H	FX3U-3A-ADP
I	FX3U-4AD-PT -ADP
J	FX3U-4AD-PTW -ADP

4.4.9 FX3U-4LC

Specifications	FX3U-4LC*1*2	
	Centigrade(°C)	Fahrenheit(°F)
Number of input points	4ch	
Input signal	Thermocouple type K, J, R, S, E, T, B, N JIS C 1602-1995 PL II, W5Re/W26Re, U, and L 3-wire platinum resistance thermometer sensor(s) Pt100 JIS C 1604-1997, JPt100 JIS C 1604-1981 2-wire/3-wire platinum resistance thermometer sensor(s) Pt1000 JIS C 1604-1997 micro voltage input	
Rated temperature range	Examples: • Type K -100°C to +1300°C • Type J -100.0°C to +800.0°C	Examples: • Type K -100°F to +2400°F • Type J -100°F to +2100°F
Digital output	Examples: • Type K -100 to +1300 • Type J -1000 to +8000	Examples: • Type K -100 to +2400 • Type J -100 to +2100
Resolution	1°C or 0.1°C	1°F or 0.1°F
Overall accuracy	Ambient temperature: 25±5°C	Measurement accuracy differs depending on the type of input, and the input range. For specification details, refer to the FX3U-4LC User's Manual.
	Ambient temperature: 0 to 55°C	Measurement accuracy differs depending on the type of input, and the input range. For specification details, refer to the FX3U-4LC User's Manual.
Cold junction temperature compensation error	±1.0°C ±2.0°C if the input value is in the range from -150°C to -100°C ±3.0°C if the input value is in the range from -200°C to -150°C	
Time required for conversion	250ms(Sampling period)	
Input characteristics	<p>●When type K (input mode 2) is set:</p>	<p>●When type K (input mode 4) is set:</p>
Insulation method	<ul style="list-style-type: none"> The photocoupler is used to insulate the analog input area from the PLC. The DC/DC converter is used to insulate the power supply from the analog inputs. Channels are insulated from each other. 	
Number of I/O points occupied	8 points (Taken from either the input or output points of the PLC.)	

*1. For FX3U-4LC, the rated temperature range, digital output value, and resolution depend on the selected sensor and mode.

*2. For a detailed description of the micro voltage input, refer to the FX3U-4LC User's Manual.

5. Version Number

5.1 PLC Main Unit

5.1.1 Manufacturer's serial number check method

The year and month of production of the PLC main unit can be checked on the nameplate, and "LOT" indicated on the front of the product.

1. Checking the nameplate

The year and month of production of the PLC main unit can be checked from the manufacturer's serial number "S/N" indicated on the label adhered to the right side of the product.

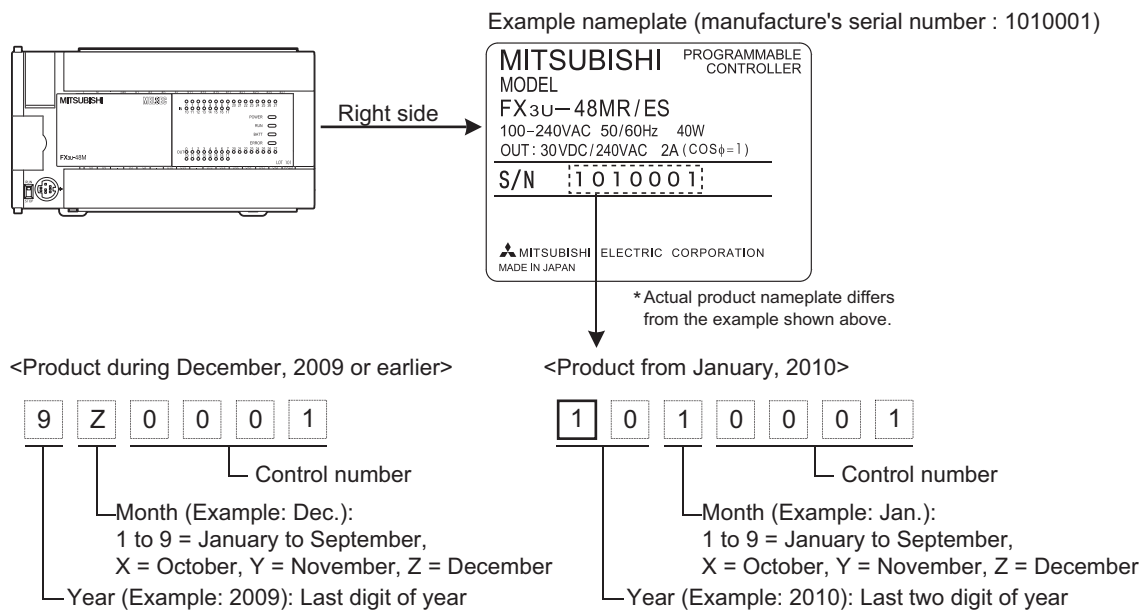

2. Checking the front of the product

The year and month of production of the PLC main unit can be checked from the manufacturer's serial number "LOT" on the front (at the bottom) of the product.

The "LOT" indication is adopted for products manufactured at the following times.

Main unit	"LOT" indication adoption time
FX3U(C) Series PLC	January 2009 and later
FX3G Series PLC	October 2008 and later

Example: FX3U-48MR/ES

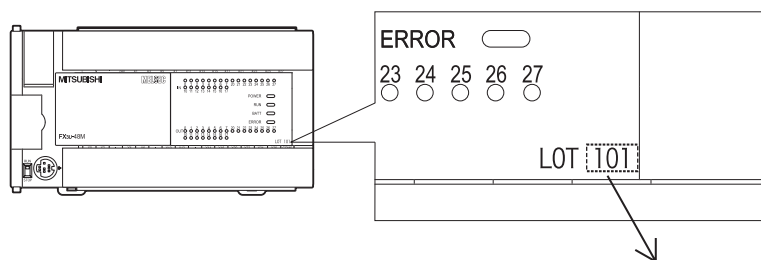

<Product during December, 2009 or earlier>

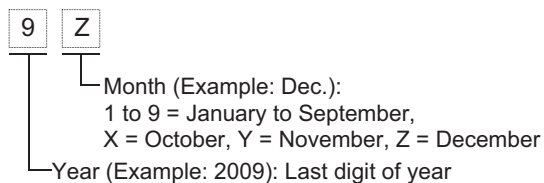

<Product from January, 2010>

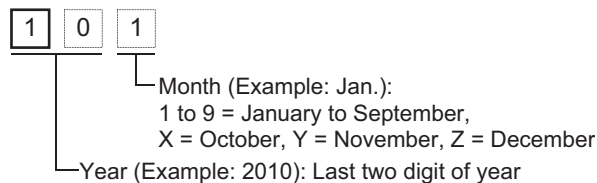

5.1.2 Version check

Special data register D8001 contains information for determining the PLC version number.

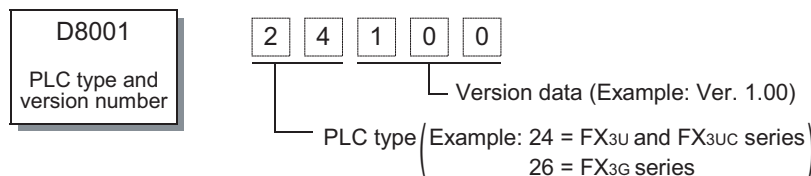

5.2 Special adapter

5.2.1 Manufacturer's serial number check method

1. Checking the nameplate

The year and month of production of the PLC main unit can be checked from the manufacturer's serial number "S/N" indicated on the label adhered to the left side of the product.

Example: FX3U-4DA-ADP
(manufacturer's serial number: 1010001)

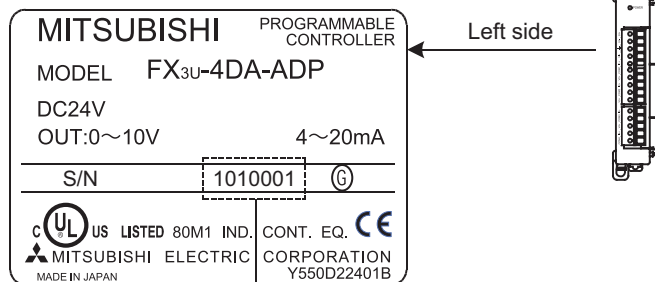

* Actual product nameplate differs from the example shown above.

<Product during December, 2009 or earlier>

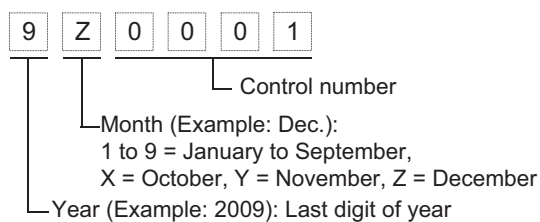

<Product from January, 2010>

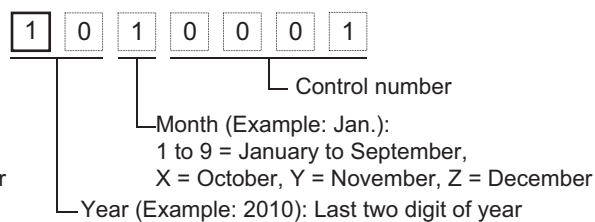

6. Manual Introduction (Types, Contents, and Obtainment)

This chapter describes the FX3U/FX3UC/FX3G Series PLC main unit instruction manual and the various manuals of analog products.

6.1 How to Use the Manuals

Various analog products can be connected to the FX Series PLC to control the analog inputs and outputs.

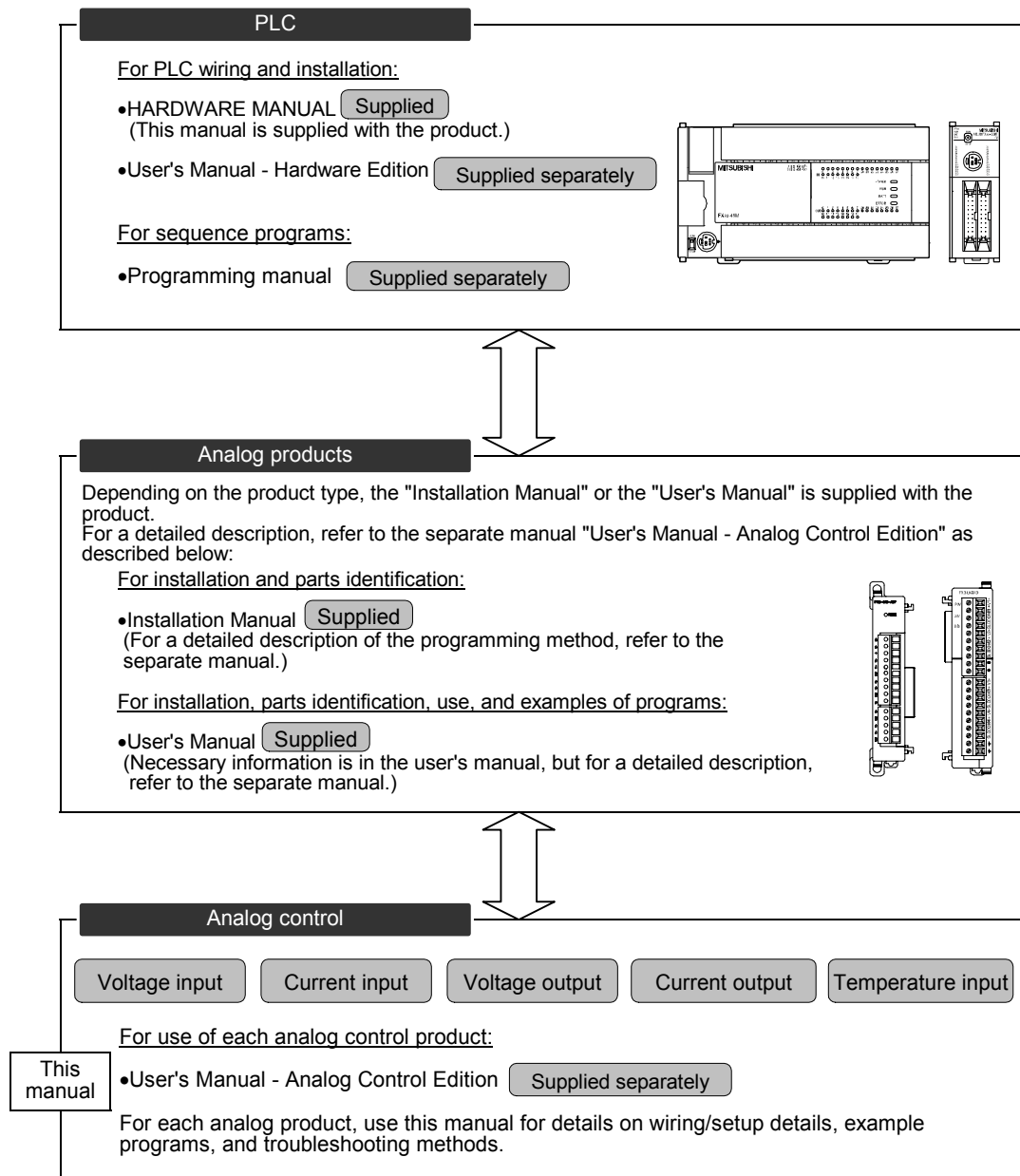

6.2 Description of Related Manuals

The main manuals necessary for the use of analog products are described below. These manuals are classified into two groups: manuals necessary for the PLC main unit, and manuals necessary for analog products. The manuals specified as "supplied separately" are not supplied with the products. Other manuals are supplied with the corresponding products.

6.2.1 Analog control manuals

The following manuals are common manuals that can be used for any of the FX3U/FX3UC/FX3G Series analog products.

Manual type	Document number	Supplied with product or supplied separately	Description
FX3G/FX3U/FX3UC Series PLC			
FX3G/FX3U/FX3UC Series User's Manual - Analog Control Edition	JY997D16701	Supplied separately (This manual)	This manual describes the details of the FX3G/ FX3U/ FX3UC Series PLC analog products.

6.2.2 Manuals related to the FX3G/FX3U/FX3UC Series PLC main unit

For a detailed description of the commands to be used for the sequence programs, refer to the programming manual. For a detailed description of the hardware, such as wiring of the PLC main unit, refer to the User's Manual - Hardware Edition.

Manual type	Document number	Supplied with product or supplied separately	Description
FX3G Series PLC			
FX3G Series HARDWARE MANUAL	JY997D33401	Supplied with product	This manual describes various items necessary for the hardware of the FX3G Series PLC main unit, such as specifications, wiring, and installation.
FX3G Series User's Manual - Hardware Edition	JY997D31301	Supplied separately	This manual describes various items necessary for the FX3G Series PLC main unit and various items for the hardware, such as extension specifications, wiring, and installation.
FX3U Series PLC			
FX3U Series HARDWARE MANUAL	JY997D18801	Supplied with product	This manual describes various items necessary for the hardware of the FX3U Series PLC main unit, such as specifications, wiring, and installation.
FX3U Series User's Manual - Hardware Edition	JY997D16501	Supplied separately	This manual describes various items necessary for the FX3U Series PLC main unit and various items for the hardware, such as extension specifications, wiring, and installation.
FX3UC Series PLC			
FX3UC (D, DS, DSS) Series HARDWARE MANUAL	JY997D28601	Supplied with product	The input/output specifications and the wiring and installation methods for the FX3UC (D, DS, DSS) PLC are excerpted from the FX3UC Series User's Manual (for Hardware). For details, refer to the FX3UC Series User's Manual (for Hardware).
FX3UC-32MT-LT-2 HARDWARE MANUAL	JY997D31601	Supplied with product	This manual describes various items necessary for the hardware of the FX3UC-32MT-LT-2 PLC main unit, such as specifications, wiring, and installation.

A	Common Items
B	FX3U-4AD FX3UC-4AD
C	FX3U-4AD-ADP
D	FX3G-2AD-BD
E	FX3U-4DA
F	FX3U-4DA-ADP
G	FX3G-1DA-BD
H	FX3U-3A-ADP
I	FX3U-4AD-PT -ADP
J	FX3U-4AD-PTW -ADP

Manual type	Document number	Supplied with product or supplied separately	Description
FX3UC Series User's Manual - Hardware Edition	JY997D28701	Supplied separately	Provides detailed information on the hardware, such as the input/output specifications and detailed wiring, installation, and maintenance methods for the FX3UC PLC.
FX3G, FX3U, FX3UC Series PLC			
FX3G/FX3U/FX3UC Series Programming Manual - Basic & Applied Instruction Edition	JY997D16601	Supplied separately	This manual describes the basic and application commands necessary for the FX3G/FX3U/FX3UC Series PLC.
MELSEC-Q/L/F Structured Programming Manual (Fundamentals)	SH-080782	Supplied separately	Programming methods, specifications, functions, etc. required to create structured programs.
FXCPU Structured Programming Manual (Device & Common)	JY997D26001	Supplied separately	Devices, parameters, etc. provided in structured projects of GX Works2.
FXCPU Structured Programming Manual (Basic & Applied Instruction)	JY997D34701	Supplied separately	Sequence instructions provided in structured projects of GX Works2.
FXCPU Structured Programming Manual (Application Functions)	JY997D34801	Supplied separately	Application functions provided in structured projects of GX Works2.

6.2.3 Manuals of analog units

The manuals of various analog units are described below:

Manual type	Document number	Supplied with product or supplied separately	Description
Analog input unit			
FX3G-2AD-BD INSTALLATION MANUAL	JY997D33501	Supplied with product	This manual describes the FX3G-2AD-BD analog input expansion board hardware, such as specifications and installation.
FX3U-4AD INSTALLATION MANUAL	JY997D20701	Supplied with product	This manual describes the FX3U-4AD analog input special function block hardware, such as specifications and installation, and also describes various programs.
FX3U-4AD-ADP USER'S MANUAL	JY997D13901	Supplied with product	This manual describes the FX3U-4AD-ADP analog input special adapter hardware, such as specifications and installation.
FX2NC-4AD USER'S MANUAL	JY997D07801	Supplied with product	This manual describes the FX2NC-4AD analog input special function block hardware, such as specifications and installation, and also describes various programs.
FX2N-8AD USER'S MANUAL	JY992D86001	Supplied with product	This manual describes the FX2N-8AD analog input special function block hardware, such as specifications and installation, and also describes various programs.
FX2N-4AD USER'S GUIDE	JY992D65201	Supplied with product	This manual describes the FX2N-4AD analog input special function block hardware, such as specifications and installation, and also describes various programs.
FX2N-2AD USER'S GUIDE	JY992D74701	Supplied with product	This manual describes the FX2N-2AD analog input special function block hardware, such as specifications and installation, and also describes various programs.
Analog output unit			
FX3G-1DA-BD INSTALLATION MANUAL	JY997D33601	Supplied with product	This manual describes the FX3G-1DA-BD analog output expansion board hardware, such as specifications and installation.
FX3U-4DA INSTALLATION MANUAL	JY997D20801	Supplied with product	This manual describes the FX3U-4DA analog output special function block hardware, such as specifications and installation.
FX3U-4DA-ADP USER'S MANUAL	JY997D14001	Supplied with product	This manual describes the FX3U-4DA-ADP analog output special adapter hardware, such as specifications and installation.
FX2NC-4DA USER'S MANUAL	JY997D07601	Supplied with product	This manual describes the FX2NC-4DA analog output special function block hardware, such as specifications and installation, and also describes various programs.
FX2N-4DA USER'S GUIDE	JY992D65901	Supplied with product	This manual describes the FX2N-4DA analog output special function block hardware, such as specifications and installation, and also describes various programs.
FX2N-2DA USER'S GUIDE	JY992D74901	Supplied with product	This manual describes the FX2N-2DA analog output special function block hardware, such as specifications and installation, and also describes various programs.
Analog input/output unit			
FX3U-3A-ADP USER'S MANUAL	JY997D35601	Supplied with product	This manual describes the FX3U-3A-ADP analog input/output special adapter hardware, such as specifications and installation.
FX2N-5A USER'S MANUAL	JY997D11401	Supplied with product	This manual describes the FX2N-5A analog input/output special function block hardware, such as specifications and installation, and also describes various programs.
FX0N-3A USER'S GUIDE	JY992D49001	Supplied with product	This manual describes the FX0N-3A analog input/output special function block hardware, such as specifications and installation, and also describes various programs.

Manual type	Document number	Supplied with product or supplied separately	Description
Temperature sensor unit			
FX3U-4AD-PT-ADP USER'S MANUAL	JY997D14701	Supplied with product	This manual describes the FX3U-4AD-PT-ADP platinum resistance thermometer input special adapter hardware, such as specifications and installation.
FX3U-4AD-PTW-ADP USER'S MANUAL	JY997D29101	Supplied with product	This manual describes the FX3U-4AD-PTW-ADP platinum resistance thermometer input special adapter hardware, such as specifications and installation.
FX3U-4AD-PNK-ADP USER'S MANUAL	JY997D29201	Supplied with product	This manual describes the FX3U-4AD-PNK-ADP resistance thermometer input special adapter hardware, such as specifications and installation.
FX3U-4AD-TC-ADP USER'S MANUAL	JY997D14801	Supplied with product	This manual describes the FX3U-4AD-TC-ADP thermocouple input special adapter hardware, such as specifications and installation.
FX2N-4AD-PT USER'S GUIDE	JY992D65601	Supplied with product	This manual describes the FX2N-4AD-PT platinum resistance thermometer input special function block hardware, such as specifications and installation, and also describes various programs.
FX2N-4AD-TC USER'S GUIDE	JY992D65501	Supplied with product	This manual describes the FX2N-4AD-TC thermocouple input special function block hardware, such as specifications and installation, and also describes various programs.
FX3U-4LC INSTALLATION MANUAL	JY997D38901	Supplied with product	This manual describes the FX3U-4LC temperature adjustment special function block hardware, such as specifications and installation.
FX3U-4LC USER'S MANUAL	JY997D39101	Supplied separately	This manual describes the FX3U-4LC temperature adjustment special function block hardware, such as specifications and installation, and also describes various programs.
FX2N-2LC USER'S GUIDE	JY992D85601	Supplied with product	This manual describes the FX2N-2LC temperature adjustment special function block hardware, such as specifications and installation.
FX2N-2LC USER'S MANUAL	JY992D85801	Supplied separately	This manual describes the FX2N-2LC temperature adjustment special function block hardware, such as specifications and installation, and also describes various programs.

7. Generic Names and Abbreviations in This Manual

1. Main unit

Abbreviation, generic name	Description
PLC	
FX Series PLC	Generic name for the FX0, FX0S, FX1S, FX0N, FX1N, FX1, FX2(FX), FX2N, FX3G, FX3U, FX1NC, FX2NC, and FX3UC Series PLC
FX3G Series	Generic name for the FX3G Series PLC
FX3G Series PLC or main unit	Generic name for the FX3G Series PLC main unit
FX3U Series	Generic name for the FX3U Series PLC
FX3U Series PLC or main unit	Generic name for the FX3U Series PLC main unit
FX3UC Series	Generic name for the FX3UC Series PLC
FX3UC Series PLC or main unit	Generic name for the FX3UC Series PLC main unit

2. Expansion board and special adapter

Abbreviation, generic name	Description
Expansion board	
Expansion board	Generic name for analog expansion board, communication expansion board, special adapter connection expansion board and variable analog potentiometer expansion board. The number of connectable units, however, depends on the type of the main unit. To check the number of connectable units, refer to the User's Manual - Hardware Edition of the main unit to be used for your system.
Analog expansion board	Generic name for 2AD-BD, 1DA-BD
2AD-BD	FX3G-2AD-BD
1DA-BD	FX3G-1DA-BD
Communication expansion board	Generic name for 232BD, 422BD, 485BD, and USBBD.
232BD	FX3U-232-BD, FX3G-232-BD, FX2N-232-BD, FX1N-232-BD
422BD	FX3U-422-BD, FX3G-422-BD, FX2N-422-BD, FX1N-422-BD
485BD	FX3U-485-BD, FX3G-485-BD, FX2N-485-BD, FX1N-485-BD
USBBD	FX3U-USB-BD
Variable analog potentiometer expansion board	Generic name for 8AV-BD
8AV-BD	FX3U-8AV-BD, FX3G-8AV-BD
Special adapter connection board or connector conversion board	Generic name for CNVBD.
CNVBD	FX3U-CNV-BD, FX2N-CNV-BD, FX1N-CNV-BD
Special adapter	
Special adapter	Generic name for high-speed input special adapter, high-speed output special adapter, communication special adapter, CF card special adapter, and analog special adapter. The number of connectable units, however, depends on the type of the main unit. To check the number of connectable units, refer to the User's Manual - Hardware Edition of the main unit to be used for your system.
High-speed input/output special adapter	Generic name for high-speed input special adapter and high-speed output special adapter.
2HSY-ADP	FX3U-2HSY-ADP
4HSX-ADP	FX3U-4HSX-ADP
Communication special adapter	Generic name for communication special adapter.
232ADP	FX3U-232ADP(-MB), FX2NC-232ADP, FX0N-232ADP, FX-232ADP
485ADP	FX3U-485ADP(-MB), FX2NC-485ADP, FX0N-485ADP, FX-485ADP

Abbreviation, generic name	Description
CF card special adapter	Generic name for CF card special adapter.
CF-ADP	FX3U-CF-ADP
Analog special adapter	Generic name for analog special adapter.
4AD-ADP	FX3U-4AD-ADP
4DA-ADP	FX3U-4DA-ADP
3A-ADP	FX3U-3A-ADP
PT-ADP	FX3U-4AD-PT-ADP
PTW-ADP	FX3U-4AD-PTW-ADP
PNK-ADP	FX3U-4AD-PNK-ADP
TC-ADP	FX3U-4AD-TC-ADP
Special adapter connection conversion adapter or connection conversion adapter	Generic name for CNVADP
CNVADP	FX3G-CNV-ADP

3. Extension unit

Abbreviation, generic name	Description
Voltage/current input	
Extension unit	Generic name for the FX3U Series extension unit, FX3UC Series extension unit, FX2N Series extension unit, FX2NC Series extension unit, and FX0N Series extension unit. The number of connectable units, however, depends on the type of the main unit. To check the number of connectable units, refer to the User's Manual - Hardware Edition of the main unit to be used for your system.
FX3U Series extension unit	Generic name for FX3U Series special function block.
FX3UC Series extension unit	Generic name for FX3UC Series special function block.
FX2N Series extension unit	Generic name for FX2N Series input/output powered extension unit, FX2N Series input/output extension block, FX2N Series special function unit, and FX2N Series special function block.
FX2NC Series extension unit	Generic name for FX2NC Series input/output extension block and FX2NC Series special function block.
FX0N Series extension unit	Generic name for FX0N Series input/output extension block and FX0N Series special function block.
Special function unit/block	Generic name for FX3U Series special function block, FX3UC Series special function block, FX2N Series special function unit, FX2N Series special function block, FX2NC Series special function block, and FX0N Series special function block.
FX3U Series special function block	FX3U-4AD, FX3U-4DA, FX3U-4LC, FX3U-2HC, FX3U-20SSC-H, FX3U-64CCL
FX3UC Series special function block	FX3UC-4AD
FX2N Series special function unit	FX2N-10GM, FX2N-20GM, FX2N-1RM-E-SET, FX2N-1RM-SET
FX2N Series special function block	FX2N-232IF, FX2N-16CCL-M, FX2N-32CCL, FX2N-32ASI-M, FX2N-2AD, FX2N-4AD, FX2N-8AD, FX2N-4AD-PT, FX2N-4AD-TC, FX2N-2LC, FX2N-2DA, FX2N-4DA, FX2N-5A, FX2N-1HC, FX2N-1PG-E, FX2N-1PG, FX2N-10PG The number of connectable units, however, depends on the type of main unit. To check the number of connectable units, refer to the User's Manual - Hardware Edition of the main unit to be used for your system.
FX2NC Series special function block	FX2NC-4AD, FX2NC-4DA, FX2NC-1HC
FX0N Series special function block	FX0N-3A

4. Peripheral unit

Abbreviation, generic name	Description
Peripheral unit	
Peripheral unit	Generic name for programming software, handy programming panel, and display units.
Programming tool	
Programming tool	Generic name for programming software, and handy programming panel.
Programming software	Generic name for Programming software.
GX Works2	Generic name for SW□DNC-GXW2-J and SW□DNC-GXW2-E programming software packages.
GX Developer	Generic name for SW□D5C-GPPW-J and SW□D5C-GPPW-E programming software packages.
Handy programming panels (HPP)	Generic name for the following models FX-30P, FX-20P(-E)-SET0, FX-20P(-E), FX-10P-SET0, FX-10P(-E)

5. Manual

Abbreviation, generic name	Description
FX3G hardware manual	FX3G Series User's Manual - Hardware Edition
FX3U hardware manual	FX3U Series User's Manual - Hardware Edition
FX3UC hardware manual	FX3UC Series User's Manual - Hardware Edition
Programming manual	FX3G/FX3U/FX3UC Series Programming Manual - Basic and Applied Instruction Edition

A

Common Items

B

FX3U-4AD
FX3UC-4AD

C

FX3U-4AD-ADP

D

FX3G-2AD-BD

E

FX3U-4DA

F

FX3U-4DA-ADP

G

FX3G-1DA-BD

H

FX3U-3A-ADP

I

FX3U-4AD-PT-ADP

J

FX3U-4AD-PTW-ADP

MEMO

FX3G/FX3U/FX3UC Series Programmable Controllers

User's Manual [Analog Control Edition] FX3U-4AD (4-channel Analog Input) FX3UC-4AD (4-channel Analog Input)

Foreword

This manual describes the specifications, wiring, and operation methods for the FX3U-4AD/FX3UC-4AD special extension block (4-channel analog input) and should be read and understood before attempting to install or use the unit.

Store this manual in a safe place so that you can take it out and read it whenever necessary. Always forward it to the end user.

This manual confers no industrial property rights or any rights of any other kind, nor does it confer any patent licenses. Mitsubishi Electric Corporation cannot be held responsible for any problems involving industrial property rights which may occur as a result of using the contents noted in this manual.

© 2005 MITSUBISHI ELECTRIC CORPORATION

A
Common Items

B
FX3U-4AD
FX3UC-4AD

C
FX3U-4AD-ADP

D
FX3G-2AD-BD

E
FX3U-4DA

F
FX3U-4DA-ADP

G
FX3G-1DA-BD

H
FX3U-3A-ADP

I
FX3U-4AD-PT
-ADP

J
FX3U-4AD-PTW
-ADP

1. Outline

This chapter outlines the FX3U-4AD/FX3UC-4AD.
 For common descriptions of the FX3U-4AD and FX3UC-4AD, these model names are referred to as the 4AD.

1.1 Outline of Functions

The FX3U-4AD is an analog special function block which is connectable with the FX3G, FX3U and FX3UC Series PLC used to capture 4-ch voltage/current data. The FX3UC-4AD cannot be connected to the FX3G/FX3U Series PLC.

- 1) Up to 8*1 units can be connected to the FX3G/FX3U/FX3UC Series PLC. (including the other special function blocks).
- 2) Either "voltage input" or "current input" can be specified for each channel.
- 3) The A/D conversion values will be stored in the 4AD buffer memory (BFM).
- 4) Set the digital filter to read out stable A/D conversion values.
- 5) For each channel, up to 1,700 A/D conversion values can be stored as history data.

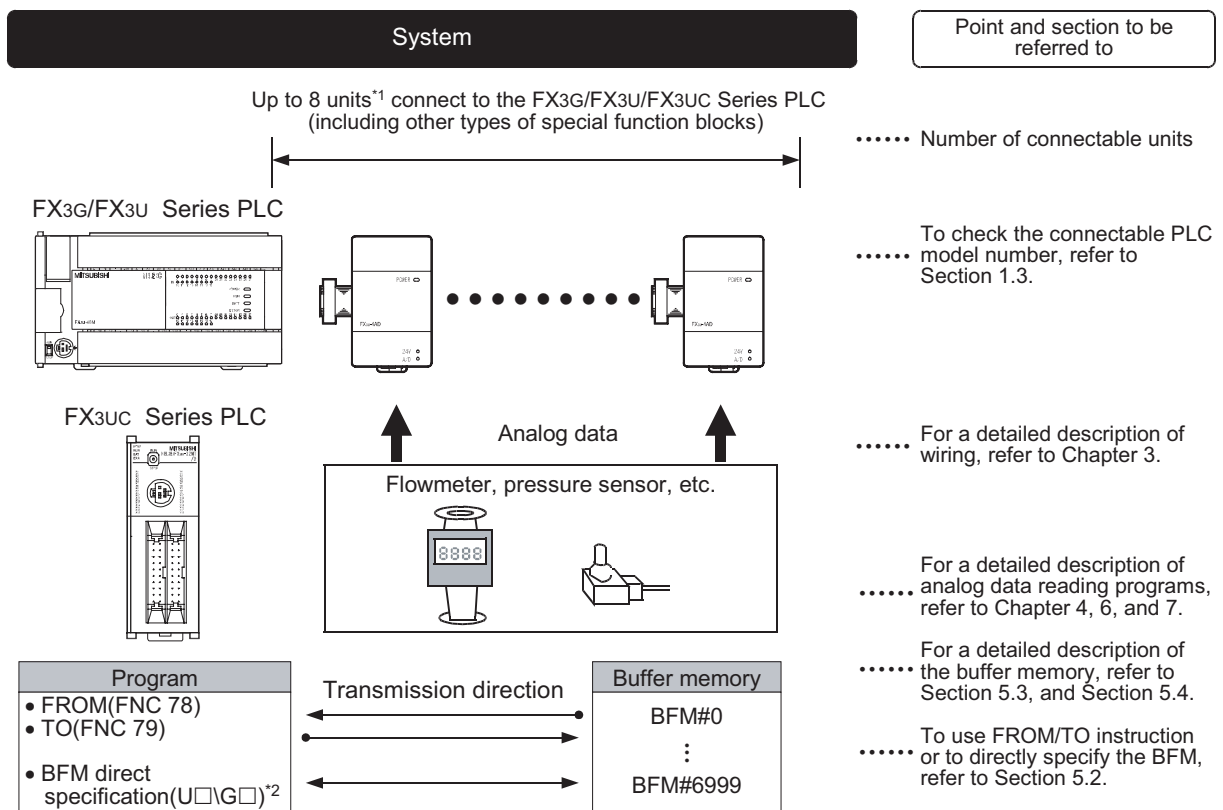

Refer to the system configuration shown in the FX3G/FX3U/FX3UC User's Manual - Hardware Edition to check the number of connectable units and to configure the entire system.

- *1. Up to 7 units can be connected to the FX3UC-32MT-LT(-2) PLC.
 *2. This function is only available for FX3U and FX3UC PLCs.

A
Common Items

B
FX3U-4AD
FX3UC-4AD

C
FX3U-4AD-ADP

D
FX3G-2AD-BD

E
FX3U-4DA

F
FX3U-4DA-ADP

G
FX3G-1DA-BD

H
FX3U-3A-ADP

I
FX3U-4AD-PT
-ADP

J
FX3U-4AD-PTW
-ADP

1.2 Setup Procedure Before Starting Operation

Before starting to use the 4AD, follow the procedure below to set up the system:

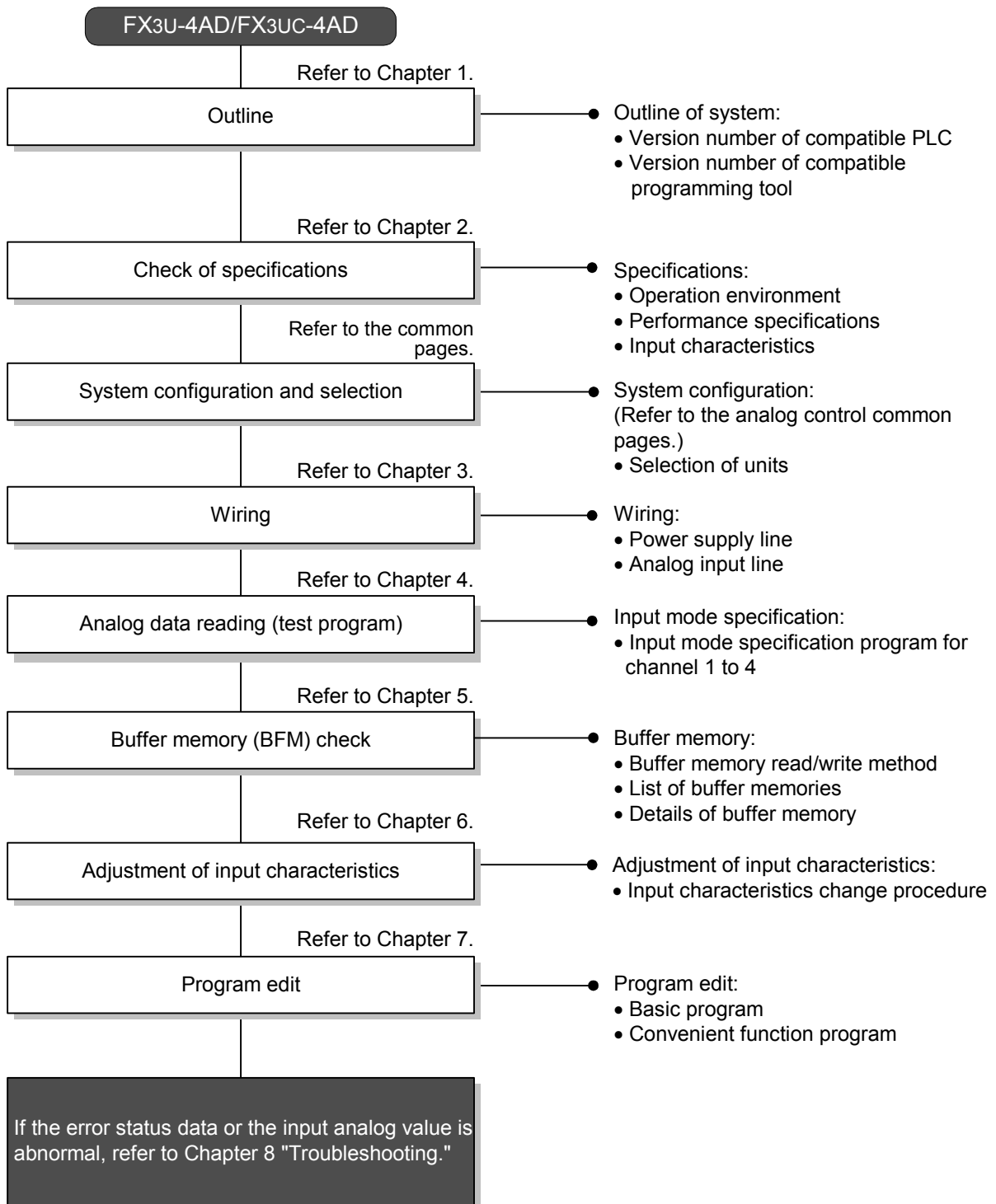

1.3 Connectable PLC and Version Numbers

FX3U-4AD is compatible with the following PLC.

Compatible PLC	Version number	Date of production
FX3U Series PLC	Ver. 2.20 or later	from first product
FX3UC Series PLC	Ver. 1.30 or later	August 2004 and later
FX3G Series PLC	Ver. 1.00 or later	from first product

FX3UC-4AD is compatible with the following PLC.

Compatible PLC	Version number	Date of production
FX3UC Series PLC	Ver. 1.30 or later	August 2004 and later

1. Version check

Special data register D8001 contains information for determining the PLC version number.

→ For a detailed description of the version check, refer to A. Common Items Subsection 5.1.2.

2. How to check the manufacturer's serial number

The year and month of production of the product can be checked on the nameplate, and on the front of the product.

→ For a detailed description of how to check the manufacturer's serial number, refer to A. Common Items Subsection 5.1.1.

1.4 Compatible Programming Tool Version Number

Use a programming tool with the following version number to create 4AD programs for the FX3G/FX3U/FX3UC Series PLC.

1. GX Works2

Software	Version number	Remarks
GX Works2 SW□DNC-GXW2-J	Ver. 1.07H or later	-
GX Works2 SW□DNC-GXW2-E	Ver. 1.08J or later	-

2. GX Developer

- FX3U/FX3UC Series PLC

Software	Version number	Remarks
GX Developer SW□D5C-GPPW-J	Ver. 8.13P or later	When selecting the model, select FX3U(C) ^{*1} .
GX Developer SW□D5C-GPPW-E	Ver. 8.18U or later	

- FX3G Series PLC

Software	Version number	Remarks
GX Developer • SW□D5C-GPPW-J • SW□D5C-GPPW-E	Ver. 8.72A or later	-

If a programming tool with the wrong version number is used, some instructions and devices cannot be used.

*1. For Ver. 8.13P to 8.24A of GX Developer, select FX3UC for the PLC type.

3. FX-30P

Model name	Version number	Remarks
FX-30P	Ver. 1.00 or later	-

2. Specifications

This chapter describes the general, power supply, and performance specifications for the 4AD.

2.1 Generic Specifications

Item	Specifications				
Ambient temperature	0 to 55°C (32 to 131°F) when operating -25 to 75°C (-13 to 167°F) when stored				
Relative humidity	5 to 95%RH (no condensation) when operating				
Vibration resistance *1	DIN Rail Mounting	Frequency (Hz)	Acceleration (m/s ²)	Half amplitude (mm)	10 times of testing in each direction (X-, Y-, and Z-axis directions) (Total: 80 min, each)
		10 - 57	-	0.035	
	Direct Mounting *2	57 - 150	4.9	-	
		10 - 57	-	0.075	
Shock resistance *1	147 m/s ² Acceleration, Action time: 11ms, 3 times by half-sine pulse in each direction X, Y, and Z	57 - 150	9.8	-	
Noise resistance	Using noise simulator of: Noise voltage: 1,000Vp-p / Noise width: 1μs / Rise: 1ns / Cycle: 30 to 100Hz				
Dielectric withstand voltage	500 V AC, for 1 min	Between all terminals and ground terminal			
Insulation resistance	5MΩ or more using 500V DC insulation resistance meter				
Grounding	Class D grounding (grounding resistance: 100 Ω or less) <Common grounding with a heavy electrical system is not allowed.>*3				
Working atmosphere	Free from corrosive or flammable gas and excessive conductive dust				
Working altitude	< 2000m*4				

*1. The criterion is shown in IEC61131-2.

*2. The direct mounting method cannot be used with FX3UC-4AD.
 When this block is connected to the FX3UC Series PLC, the direct mounting method cannot be used.

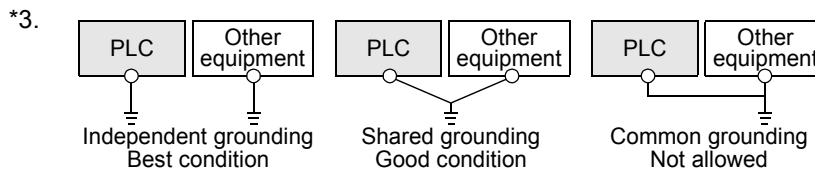

→ For a detailed description of grounding, refer to Section 3.5.

*4. If the pressure is higher than the atmospheric pressure, do not use the 4AD; 4AD may malfunction.

2.2 Power Supply Specifications

FX3U-4AD

Item	Specifications
A/D conversion circuit drive power	24V DC $\pm 10\%$, 90mA (It is necessary to supply 24V DC from the terminal block.)
CPU drive power	5V DC, 110mA (Since the internal power is supplied from the main unit, it is not necessary to supply power externally.)

FX3UC-4AD

Item	Specifications
A/D conversion circuit drive power	24V DC $\pm 10\%$, 80mA (It is necessary to supply 24V DC from the power connector.)
CPU drive power	5V DC, 100mA (Since the internal power is supplied from the main unit, it is not necessary to supply the power.)

2.3 Performance Specifications

Item	Specifications	
	Voltage input	Current input
Analog input range	-10V to +10V DC (Input resistance: 200k Ω)	-20mA to +20mA DC, 4mA to 20mA DC (Input resistance: 250 Ω)
Offset ^{*1}	-10V to +9V ^{*2}	-20mA to +17mA ^{*3}
Gain ^{*1}	-9V to +10V ^{*2}	-17mA to +30mA ^{*3}
Absolute maximum input	$\pm 15V$	$\pm 30mA$
Digital output	With sign, 16bits, binary	With sign, 15bits, binary
Resolution ^{*4}	0.32mV (20V \times 1/ 64,000) 2.5mV (20V \times 1/8000)	1.25 μA (40mA \times 1/ 32,000) 5.00 μA (40mA \times 1/8000)
Overall accuracy	<ul style="list-style-type: none"> Ambient temperature: 25°C\pm5°C $\pm 0.3\%$ ($\pm 60mV$) for 20V full scale Ambient temperature: 0°C to 55°C $\pm 0.5\%$ ($\pm 100mV$) for 20V full scale 	<ul style="list-style-type: none"> Ambient temperature: 25°C\pm5°C $\pm 0.5\%$ ($\pm 200\mu A$) for 40mA full scale Same accuracy ($\pm 200\mu A$) for 4mA to 20mA input Ambient temperature: 0°C to 55°C $\pm 1\%$ ($\pm 400\mu A$) for 40mV full scale Same accuracy ($\pm 400\mu A$) for 4mA to 20mA input
Time required for A/D conversion	500 μs \times number of selected channels (If 1 or more channels use the digital filter(s): 5ms \times number of selected channels)	
Insulation method	<ul style="list-style-type: none"> The photocoupler is used to insulate the analog input area from the PLC. The DC/DC converter is used to insulate the analog input area from the power supply unit. Channels are not insulated from each other. 	
Number of I/O points occupied	8 points (Taken from either the input or output points of the PLC.)	

- *1. Adjustment of the offset or gain value will not affect the resolution. In the direct indication mode, however, the offset/gain cannot be adjusted.
- *2. The offset and the gain should satisfy the following condition:
 $1V \leq (\text{Gain} - \text{Offset})$
- *3. The offset and the gain should satisfy the following condition:
 $3 \text{ mA} \leq (\text{Gain} - \text{Offset}) \leq 30 \text{ mA}$
- *4. If 1 or more channels use the digital filter(s), the time required for A/D conversion will be "5 ms \times number of selected channels."

2.4 Input Mode (Characteristics) BFM #0

For the 4AD, there are two types of input characteristics: voltage (-10 to +10V) and current (4 to 20mA, -20 to +20mA) input characteristics. The input characteristics depend on the set input mode as described below. For each input range, there are 3 input modes.

1. Voltage input characteristics [-10 to +10V] (Input mode: 0 to 2)

Set input mode: 0
 Input type: Voltage input
 Analog input range: -10 to +10V
 Digital output range: -32000 to +32000
 Offset/gain adjustment: Possible

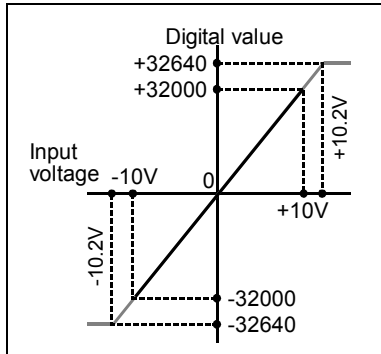

Set input mode: 1
 Input type: Voltage input
 Analog input range: -10 to +10V
 Digital output range: -4000 to +4000
 Offset/gain adjustment: Possible

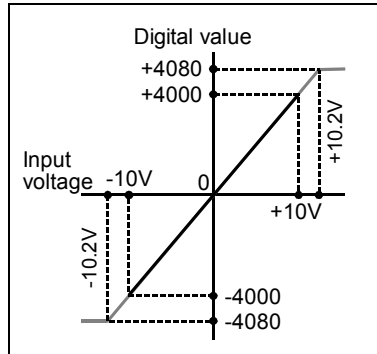

Set input mode: 2
 Input type: Voltage input
 (analog value direct indication)
 Analog input range: -10 to +10V
 Digital output range: -10000 to +10000
 Offset/gain adjustment: Impossible

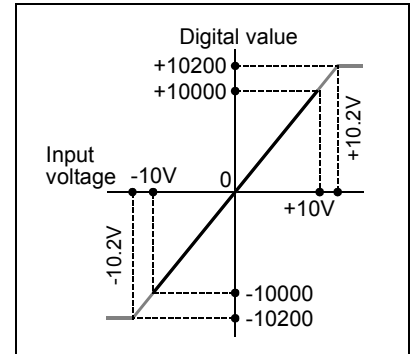

2. Current input characteristics [4 to 20mA] (Input mode: 3 to 5)

Set input mode: 3
 Input type: Current input
 Analog input range: 4 to 20mA
 Digital output range: 0 to 16000
 Offset/gain adjustment: Possible

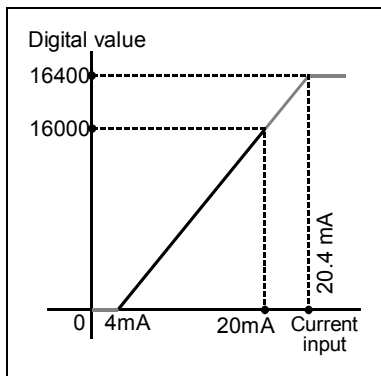

Set input mode: 4
 Input type: Current input
 Analog input range: 4 to 20 mA
 Digital output range: 0 to 4000
 Offset/gain adjustment: Possible

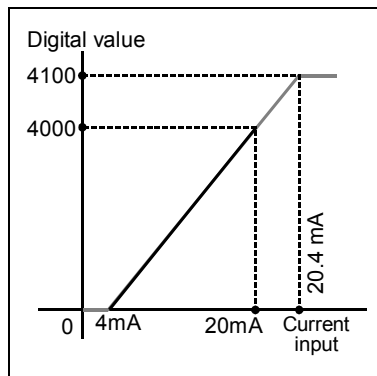

Set input mode: 5
 Input type: Current input
 (analog value direct indication)
 Analog input range: 4 to 20 mA
 Digital output range: 4000 to 20000
 Offset/gain adjustment: Impossible

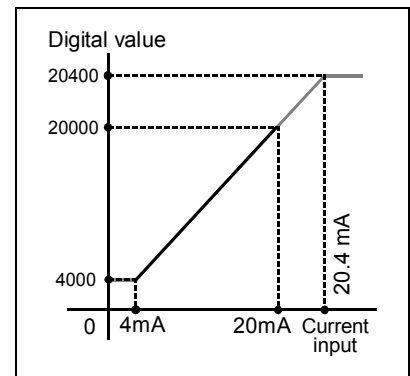

3. Current input characteristics [-20 to +20mA] (Input mode: 6 to 8)

Set input mode: 6
 Input type: Current input
 Analog input range: -20 to +20mA
 Digital output range: -16000 to +16000
 Offset/gain adjustment: Possible

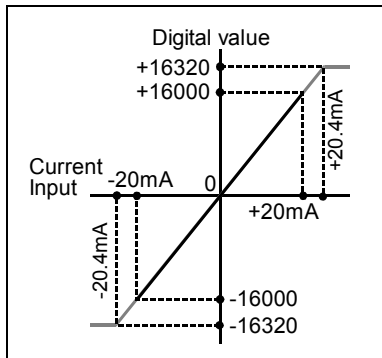

Set input mode: 7
 Input type: Current input
 Analog input range: -20 to +20mA
 Digital output range: -4000 to +4000
 Offset/gain adjustment: Possible

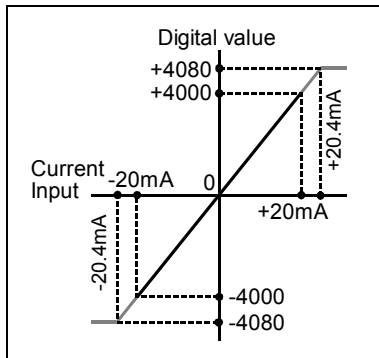

Set input mode: 8
 Input type: Current input
 (analog value direct indication)
 Analog input range: -20 to +20mA
 Digital output range: -20000 to +20000
 Offset/gain adjustment: Impossible

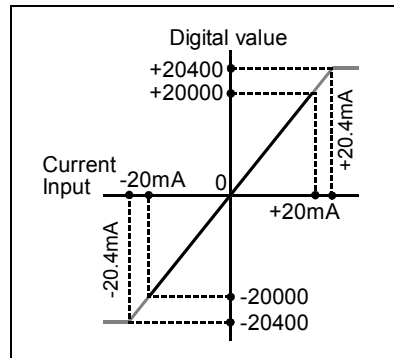

A

Common Items

B

FX3U-4AD
 FX3UC-4AD

C

FX3U-4AD-ADP

D

FX3G-2AD-BD

E

FX3U-4DA

F

FX3U-4DA-ADP

G

FX3G-1DA-BD

H

FX3U-3A-ADP

I

FX3U-4AD-PT-ADP

J

FX3U-4AD-PTW-ADP

3. Wiring

This chapter describes the 4AD wiring.
Observe the following cautions when wiring the 4AD.

WIRING PRECAUTIONS



DANGER

- Make sure to cut off all phases of the power supply externally before attempting wiring work. Failure to do so may cause electric shock or damages to the product.

WIRING PRECAUTIONS



CAUTION

- Connect the DC power supply wiring to the dedicated terminals described in this manual. If an AC power supply is connected to a DC input/output terminal or DC power supply terminal, the PLC will be burnt out.
- Do not wire vacant terminals externally. Doing so may damage the product.
- Perform class D grounding (grounding resistance: 100Ω or less) to the grounding terminal on the main unit. Do not use common grounding with heavy electrical systems.
- When drilling screw holes or wiring, make sure cutting or wire debris does not enter the ventilation slits. Failure to do so may cause fire, equipment failures or malfunctions.
- Make sure to observe the following precautions in order to prevent malfunctions under the influence of noise:
 - Do not bundle the power line or twisted shielded cable together with or lay it close to the main circuit, high-voltage line, or load line. Otherwise, noise disturbance and/or surge induction are likely to take place. As a guideline, lay the control line at least 100mm (3.94") or more away from the main circuit, high-voltage line, or load line.
 - Ground the shield of the analog input/output cable at one point on the signal receiving side. However, do not use common grounding with heavy electrical systems.
- Make sure to properly wire to the European terminal board in accordance with the following precautions. Failure to do so may cause electric shock, equipment failures, a short-circuit, wire breakage, malfunctions, or damage to the product.
 - The disposal size of the cable end should follow the dimensions described in the manual.
 - Tightening torque should follow the specifications in the manual.
 - Twist the end of strand wire and make sure there are no loose wires.
 - Do not solder-plate the electric wire ends.
 - Do not connect more than the specified number of wires or electric wires of unspecified size.
 - Affix the electric wires so that neither the terminal block nor the connected parts are directly stressed.
- Make sure to properly wire the terminal block in accordance with the following precautions. Failure to do so may cause electric shock, equipment failures, a short-circuit, wire breakage, malfunctions, or damage to the product.
 - The disposal size of the cable end should follow the dimensions described in the manual.
 - Tightening torque should follow the specifications in the manual.

3.1 Terminal Layout

FX3U-4AD

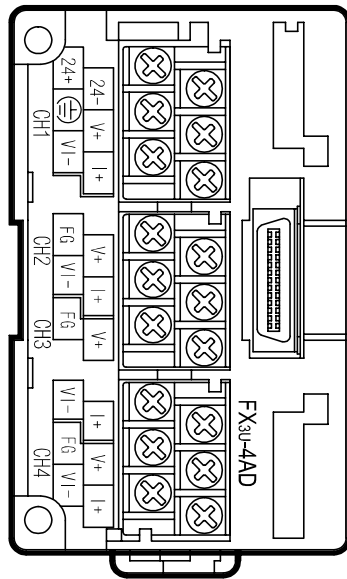

Signal	Application
24+	24V DC power supply
24-	
⊕	Ground terminal
V+	Channel-1 analog input
VI-	
I+	
FG	Channel-2 analog input
V+	
VI-	
I+	Channel-3 analog input
FG	
V+	
VI-	Channel-4 analog input
I+	
FG	

FX3UC-4AD

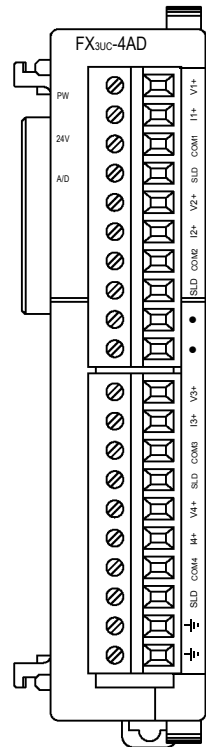

Signal	Application
V1+	Channel-1 analog input
I1+	
COM1	
SLD	Channel-2 analog input
V2+	
I2+	
COM2	Do not connect any lines.
SLD	
•	
V3+	Channel-3 analog input
I3+	
COM3	
SLD	Channel-4 analog input
V4+	
I4+	
COM4	Ground terminal
SLD	
⊕	

A
Common Items

B
FX3U-4AD
FX3UC-4AD

C
FX3U-4AD-ADP

D
FX3G-2AD-BD

E
FX3U-4DA

F
FX3U-4DA-ADP

G
FX3G-1DA-BD

H
FX3U-3A-ADP

I
FX3U-4AD-PT-ADP

J
FX3U-4AD-PTW-ADP

3.2 Cable and Terminal Tightening Torque

3.2.1 Power cable (FX3UC-4AD)

The power crossover cable (type "C" shown in the following table) is supplied with the FX3UC-4AD. To connect the power cable, refer to the User's Manual - Hardware Edition of the PLC main unit. There are 3 types of power cables as shown in the following table. Types "A" and "B" are supplied with the main unit, and type "C" is supplied with the input extension blocks or the special function blocks for FX3UC Series.

Type	Application	Model	Length	Cable supplied with
A	Power cable for main unit	FX2NC-100MPCB	1m (3' 3")	FX3UC Series PLC main unit
B	Input power cable for input extension block	FX2NC-100BPCB	1m (3' 3")	
C	Input power crossover cable for input extension block	FX2NC-10BPCB1	0.1m (0' 3")	<ul style="list-style-type: none"> Input extension block for FX2NC Series Special function block for FX3UC/FX2NC Series

The crossover cable (type "C") can skip up to 4 16-point output blocks to connect units. If more blocks should be skipped to supply power to an input block, use cable type "B".

<Self-made power cable>

To use self-made power cables, use the following wire rods and connectors:

		Specifications/model
Wire size		AWG24 (0.2mm ²)
Crimp-style terminal		1602-0069 (manufactured by Molex Japan Co., Ltd.)
Housing	For main unit	51030-0330 (manufactured by Molex Japan Co., Ltd.)
	For input extension block	51030-0230 (manufactured by Molex Japan Co., Ltd.)

Supply the 24V DC power to FX3UC-4AD via the power supply connector.

3.2.2 Cable (FX3U-4AD)

The FX3U-4AD terminal block is designed for M3 screws.

The end disposal of the cable shows blow.

Tighten the terminal to a torque of 0.5 to 0.8 N·m.

Do not tighten terminal screws with a torque exceeding the regulation torque.

Failure to do so may cause equipment failures or malfunctions.

- When one wire is connected to one terminal

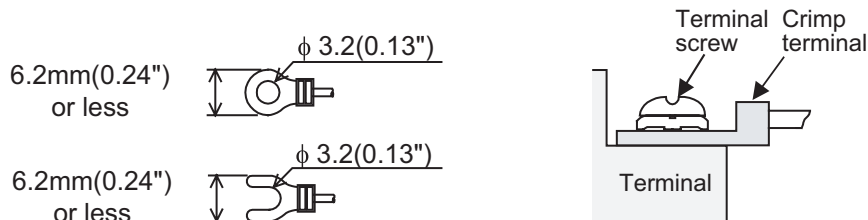

- When two wires are connected to one terminal

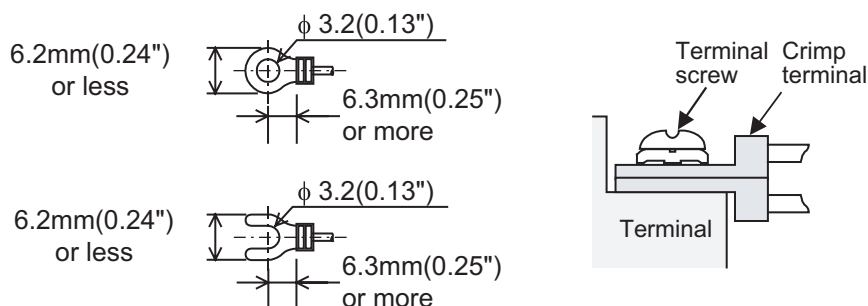

3.2.3 Cable (FX3UC-4AD)

Use the following cables to connect with counterpart equipment. Terminate the cable end as shown below.

1. Cable

Applicable cable and tightening torque

	Wire size (stranded/ single-wire)	Tightening torque	Termination
Single wire	0.3mm ² to 0.5mm ² (AWG22 to 20)	0.22N•m to 0.25N•m	<ul style="list-style-type: none"> To connect a stranded cable, peel the cover off the cable and then twist the core before connection. To connect a single-wire cable, peel the cover off the cable before connection. Rod terminal with insulation sleeve (recommended terminal) AI 0.5-8WH : Manufactured by Phoenix Contact Caulking tool CRIMPFOX 6*1 : Manufactured by Phoenix Contact (or CRIMPFOX 6T-F*2 : Manufactured by Phoenix Contact)
Double wire	0.3mm ² (AWG22)		
Rod terminal with insulation sleeve	0.3mm ² to 0.5mm ² (AWG22 to 20) (Refer to the external view of rod terminal shown in the following figure.)		

- *1. Old model name : CRIMPFOX ZA 3
- *2. Old model name : CRIMPFOX UD 6

2. Termination of cable end

To terminate the cable, treat the stranded/single-wire directly or use the rod terminal with insulation sleeve.

- To directly terminate end of stranded/single-wire cable:
 - Terminate the end of the stranded cable so that the "barbed wires" cannot protrude.
 - Do not solder-plate the end of the cable.
- To terminate cable end using rod terminal with insulation sleeve:
 If the cable sheath is too thick, it may be difficult to insert the cable into the insulation sleeve. For this reason, select an appropriate cable while referring to the external view.

<Reference>

Manufacturer	Model	Caulking tool
Phoenix Contact	AI 0.5-8WH	CRIMPFOX 6*3 (or CRIMPFOX 6T-F*4)

- *3. Old model name : CRIMPFOX ZA 3
- *4. Old model name : CRIMPFOX UD 6

3. Tool

- To tighten terminals, use a purchased small-sized screwdriver whose head is straight and is not widened as shown in the right figure.

Note:

If the diameter of screwdriver grip is too small, tightening torque will not be able to be achieved. To achieve the appropriate tightening torque shown in the table above, use the following screwdriver or an appropriate replacement (grip diameter: approximately 25mm (0.98")).

<Reference>

Manufacturer	Model
Phoenix Contact	SZS 0.4×2.5

Termination of cable end

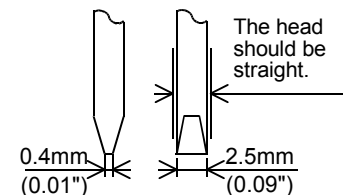
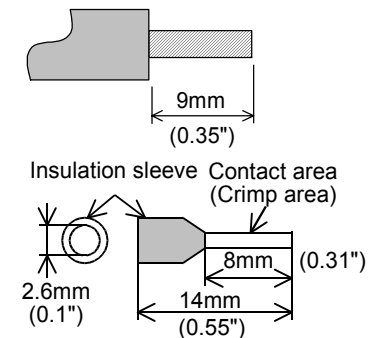

3.3 Examples of Power Supply Circuit

3.3.1 FX3U-4AD

Below are shown examples of circuits for using the 24V DC service power supply of the FX3G/FX3U Series PLC.

1) Sink input [- common] wiring

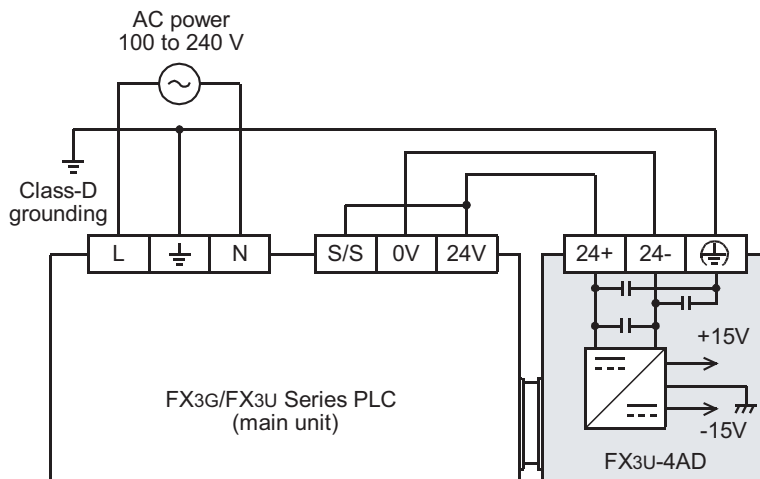

Connect the "S/S" terminal of the main unit to the "24V" terminal.

2) Source input [+ common] wiring

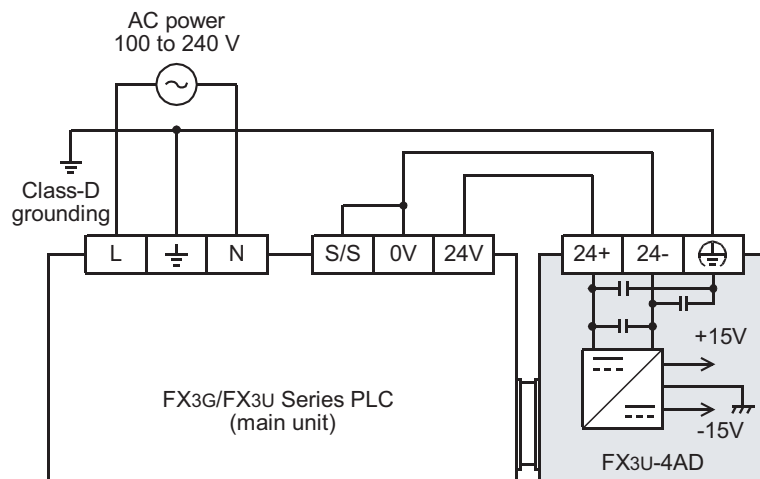

Connect the "S/S" terminal of the main unit to the "0V" terminal.

3.3.2 FX3UC-4AD

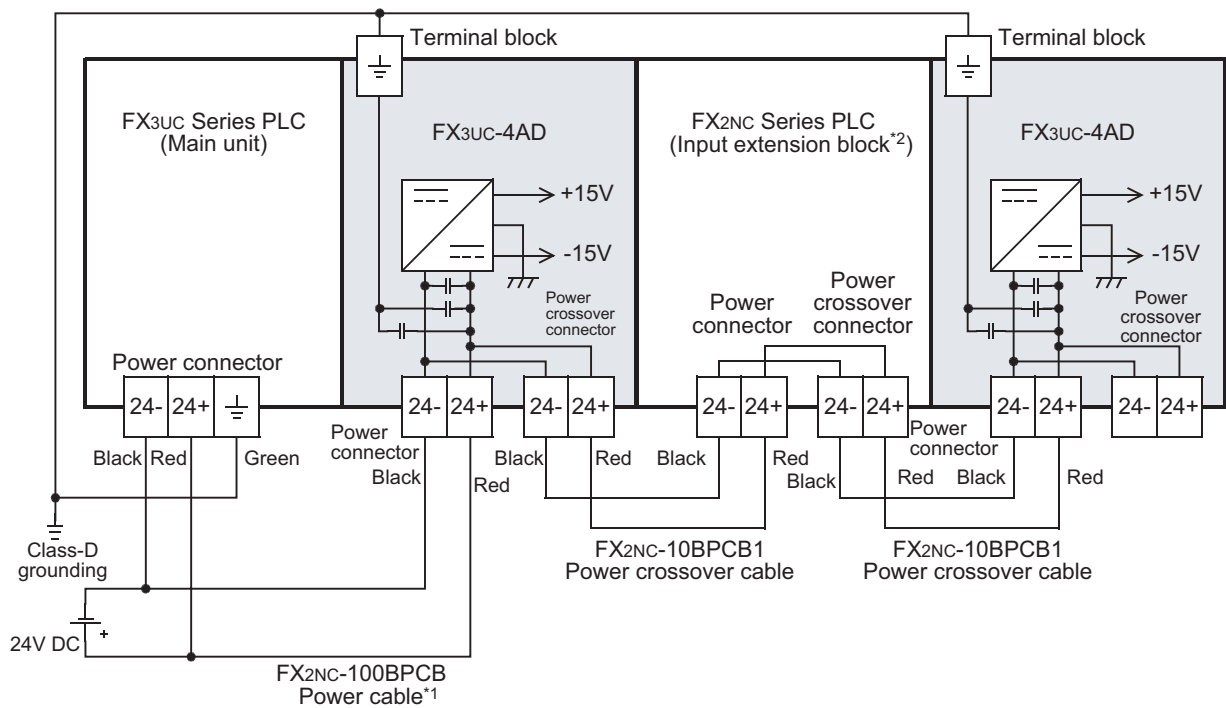

*1. The FX3UC-□□MT/D and FX3UC-32MT-LT(-2) are supplied together with power cable.

*2. The FX2NC-□□EX-DS and FX2NC-16EX-T-DS do not have a power connector, and receive power from the input connector.

3.3.3 Cautions regarding connection of power cables

- Ground the " \perp " terminal and " \oplus " terminal to the Class - D grounding line (100 Ω or less) together with the ground terminal of the main unit.
- To perform crossover wiring to connect the power line from FX3UC-4AD to a succeeding extension block, remove the resin cover from the power crossover connector using nippers.
- For the timing of power-on/off when using an external power supply, see the following manual of the connected PLC.
 - Refer to the **FX3G Series User's Manual - Hardware Edition**.
 - Refer to the **FX3U Series User's Manual - Hardware Edition**.
 - Refer to the **FX3UC Series User's Manual - Hardware Edition**.

3.4 Analog Input Line

The analog input type, "voltage input" or "current input", can be selected for each channel.

3.4.1 FX3U-4AD

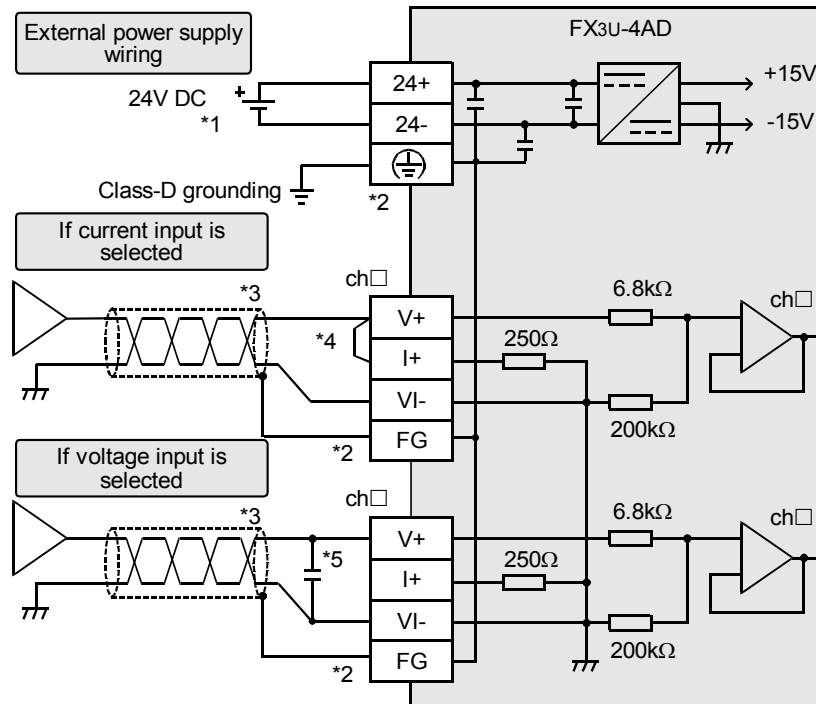

ch□ : □ represents the channel number.

- *1. For FX3G/FX3U Series PLC (AC power type), the 24V DC service power supply is also available.
- *2. The [FG] terminal and the [⊕] terminal are connected internally.
There is no "FG" terminal for ch1. When using ch1, connect directly to the [⊕] terminal.
- *3. Use a 2-core twisted shield wire for analog input line, and separate it from other power lines or inductive lines.
- *4. For the current input, short-circuit the [V+] terminal and the [I+] terminal.
- *5. If there is voltage ripple in the input voltage or there is noise in the external wiring, connect a capacitor of approximately 0.1 to 0.47μF 25 V.

3.4.2 FX3UC-4AD

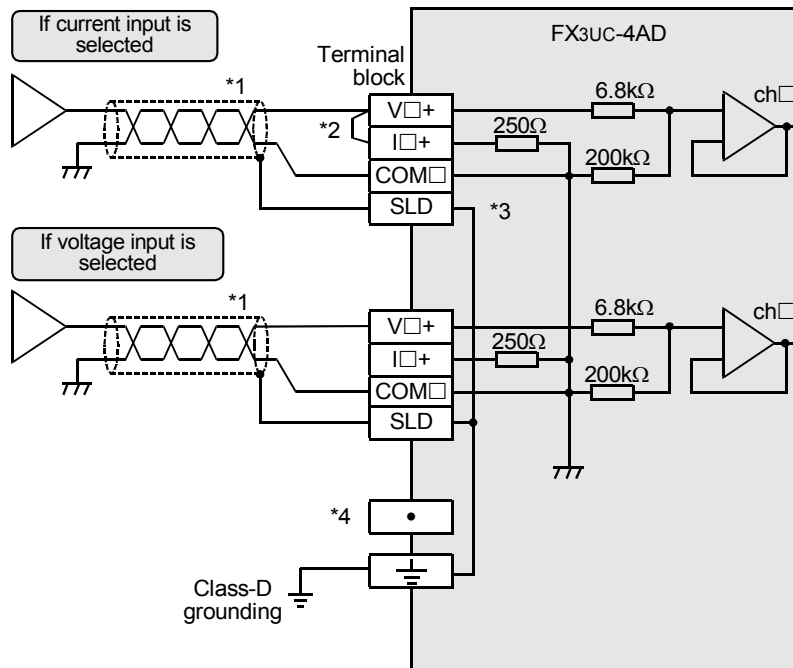

V□+, I□+, ch□ : □ represents the channel number.

- *1. Use the 2-core shielded twisted pair cable for the analog input lines, and separate the analog input lines from the other motive power lines or inductive lines.
- *2. To use the current input, be sure to short circuit the line between the V□ + terminal and the I□ + terminal (□ : channel number).
- *3. The SLD and "⏏" terminals are connected to each other inside.
- *4. Do not connect any lines to the "•" terminal.

3.5 Grounding

Grounding should be performed as stated below.

- The grounding resistance should be 100Ω or less.
- Independent grounding should be performed for best results. When independent grounding is not performed, perform "shared grounding" as shown in the following figure.

→ For details, refer to the User's Manual - Hardware Edition of each Series.

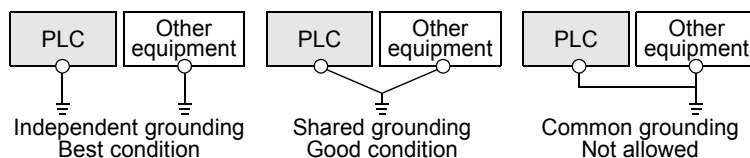

- Use the following grounding wire.

FX3u-4AD	AWG14 (2mm ²)
FX3uc-4AD	AWG22-20 (0.3 to 0.5mm ²)

- The PLC grounding point should be close, and all grounding wires should be as short as possible.

4. Analog Input

This chapter describes the minimum programming necessary to readout the 4AD analog data. Follow the procedure below to confirm that the analog data can be properly read out.

4.1 Analog Input Procedures

1 Unit number check

Unit numbers from 0 to 7 will be assigned to the special function units/blocks starting from the left. When units/blocks are connected to the FX3UC-32MT-LT(-2) PLC, unit numbers from 1 to 7 are assigned. Check the unit number assigned to the 4AD.

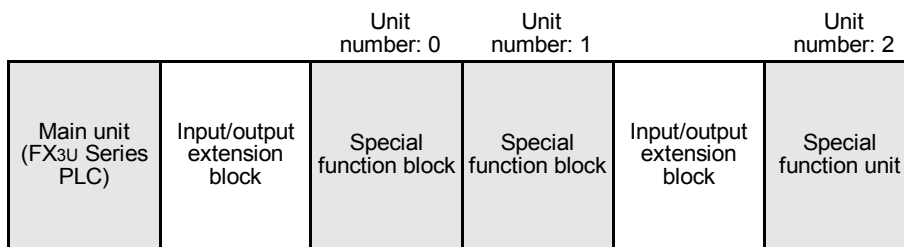

2 Input mode (BFM #0) setting

Depending on the analog signal generator to be connected, set the input mode (BFM #0) for each channel.

Use hexadecimal numbers for input mode setting. Set the corresponding channel digit to the input mode setting value specified in the following table:

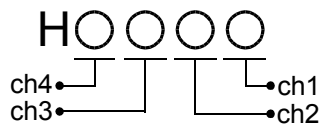

Setting value	Input mode	Analog input range	Digital output range
0	Voltage input mode	-10V to +10V	-32000 to +32000
1	Voltage input mode	-10V to +10V	-4000 to +4000
2	Voltage input Analog value direct indication mode	-10V to +10V	-10000 to +10000
3	Current input mode	4mA to 20mA	0 to 16000
4	Current input mode	4mA to 20mA	0 to 4000
5	Current input mode Analog value direct indication mode	4mA to 20mA	4000 to 20000
6	Current input mode	-20mA to +20mA	-16000 to +16000
7	Current input mode	-20mA to +20mA	-4000 to +4000
8	Current input mode Analog value direct indication mode	-20mA to +20mA	-20000 to +20000
F	Channel not used		

→ For a detailed description of the standard input characteristics, refer to Section 2.4.

→ For a detailed description of the input mode (BFM #0), refer to Subsection 5.4.1.

3 Creation of sequence program

Create the program as follows to read analog signals.

- While referring to step 2, set the input mode "H****".
- While referring to step 1, set the unit number in □
 - Program Example (For FX3U, FX3UC Series PLCs)*1

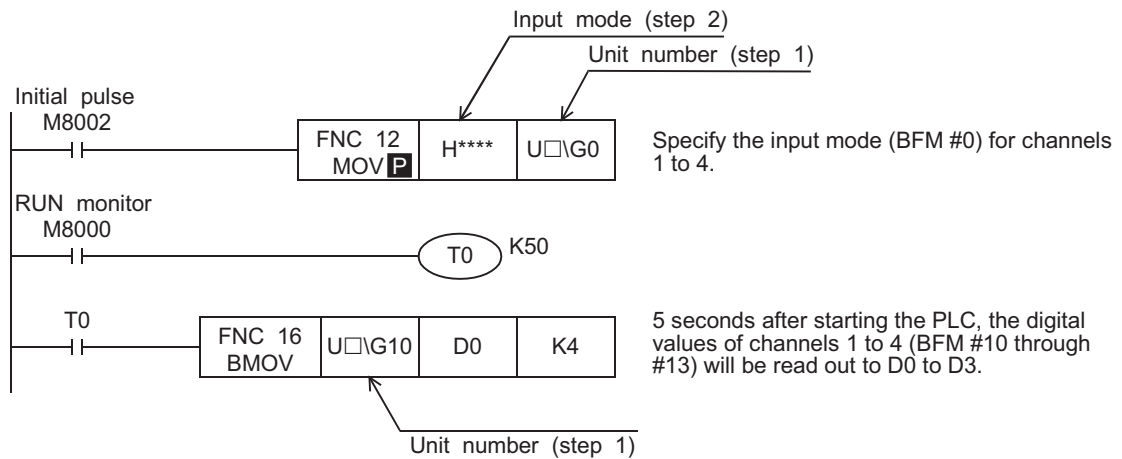

*1. Use the FROM and TO instructions in FX3G PLCs.

4 Sequence program transfer and data register check

- 1) Transfer the sequence program, and start the PLC.
- 2) The 4AD analog data input mode will be stored in data registers (D0 to D3) of the PLC.
- 3) Check that the data is stored in D0 to D3.

→ If the data is not properly stored, refer to Chapter 8 "Troubleshooting."

A	Common Items
B	FX3U-4AD FX3UC-4AD
C	FX3U-4AD-ADP
D	FX3G-2AD-BD
E	FX3U-4DA
F	FX3U-4DA-ADP
G	FX3G-1DA-BD
H	FX3U-3A-ADP
I	FX3U-4AD-PT -ADP
J	FX3U-4AD-PTW -ADP

5. Buffer Memory (BFM)

This chapter describes the buffer memory incorporated in 4AD.

5.1 Assignment of Unit Numbers and Outline of Buffer Memory

1. Assignment of unit numbers

Unit numbers from 0 to 7 will be assigned to the special function units/blocks starting from the left. When the units/blocks are connected to the FX3UC-32MT-LT(-2) PLC, unit numbers from 1 to 7 are assigned.

When connected to the FX3G/FX3U/FX3UC (D, DS, DSS) Series PLC

		Unit number: 0	Unit number: 1			Unit number: 2
Main unit	Input/output extension block	Special function block	Special function block	Input/output extension block		Special function unit

When connected to the FX3UC-32MT-LT(-2) PLC

Unit number: 0 (Incorporated CC-Link/LT)			Unit number: 1	Unit number: 2			Unit number: 3
Main unit (FX3UC-32MT -LT(-2))	Input/output extension block		Special function block	Special function block	Input/output extension block		Special function unit

2. Outline of buffer memory

The analog signals input into the 4AD will be converted into digital values and then stored in the 4AD buffer memory.

To switch the input mode between voltage input and current input, or to adjust the offset or gain, numeric data will be sent from the main unit and written/set in the 4AD buffer memory.

To read/write data from/to the 4AD buffer memory, the buffer memory can be directly specified using the FROM/TO instruction or an applied instruction. Using this function, sequence programs can be easily created.

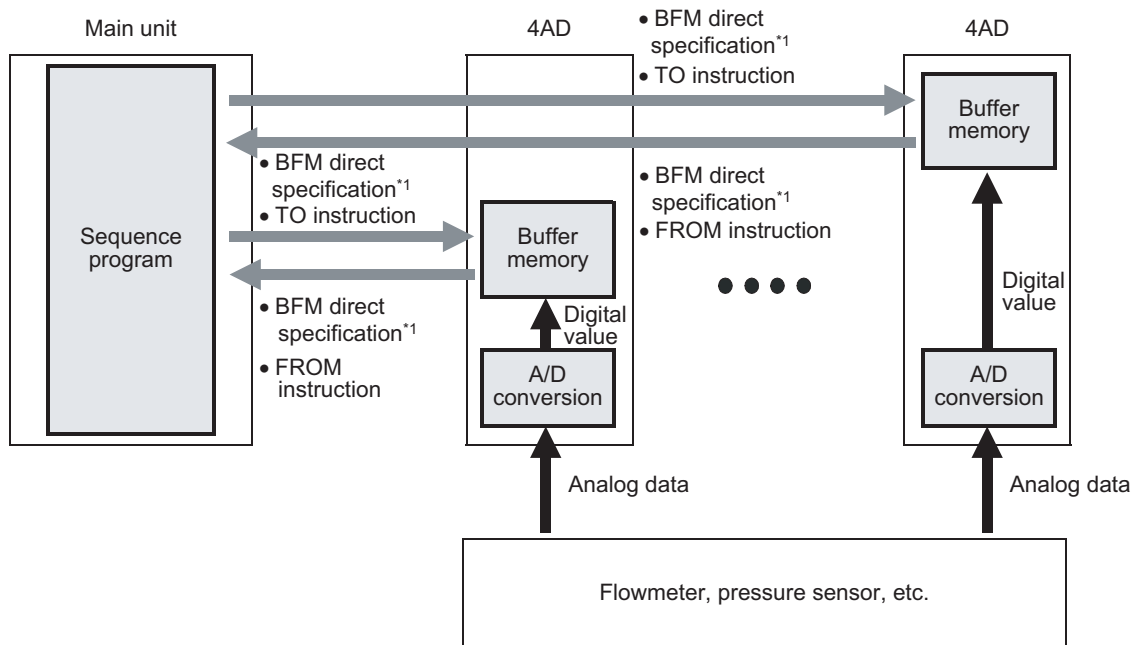

*1. Since buffer memory direct specification (U□\G□) can directly specify the buffer memory in the source or destination area of an applied instruction, programs can be created efficiently. (This function is supported only in FX3U/FX3UC PLCs.)

→ For a detailed description of buffer memory reading/writing, refer to Section 5.2.
 → For a detailed description of the buffer memory, refer to Section 5.4.

A Common Items
B FX3U-4AD / FX3UC-4AD
C FX3U-4AD-ADP
D FX3G-2AD-BD
E FX3U-4DA
F FX3U-4DA-ADP
G FX3G-1DA-BD
H FX3U-3A-ADP
I FX3U-4AD-PT-ADP
J FX3U-4AD-PTW-ADP

5.2 Buffer Memory Reading/Writing Method

To read or write to the 4AD buffer memory, use the FROM/TO instructions or buffer memory direct specifications*1.

However, to use buffer memory direct specification*1, software compatible with FX3U/FX3UC Series PLCs is required.

*1. This function is supported only in FX3U/FX3UC PLCs.

→ For a detailed description of software compatible with the FX3U/FX3UC Series PLC, refer to Section 1.4.

5.2.1 Buffer memory direct specification (FX3U, FX3UC PLC only)

When directly specifying the buffer memory, specify the following device in the source or destination area of the applied instruction as follows:

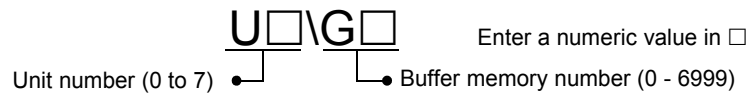

1. Example 1

If the following program is created, data in buffer memory (BFM #10) of unit 1 will be multiplied by the data (K10), and then the multiplication result will be output to data registers (D10, D11).

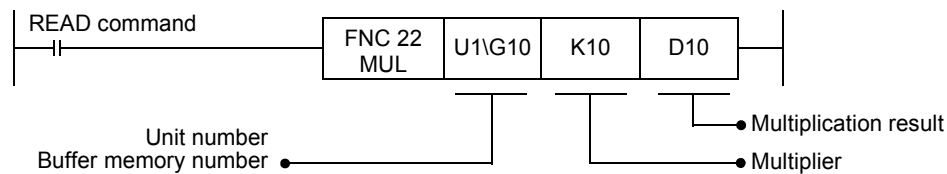

2. Example 2

If the following program is created, the value in data register (D20) is added to K10 and written to buffer memory (BFM #6) of unit 1.

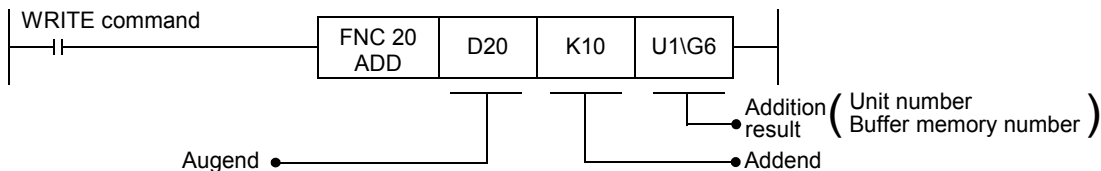

5.2.2 FROM/TO instruction (FX3G, FX3U, FX3UC PLC)

1. FROM instruction (Reading out BFM data to PLC)

Use the FROM instruction to read the data from the buffer memory.

In a sequence program, use this instruction as follows:

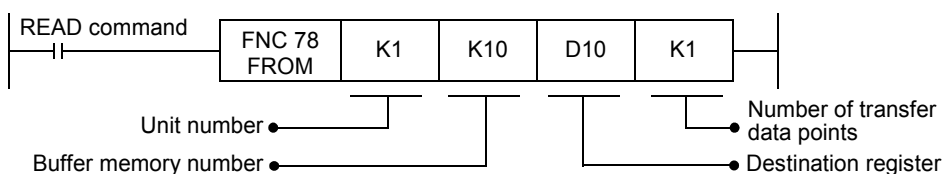

If the above program is created, 1 point of data will be read out from the buffer memory BFM #10 of unit No.1 to data register D10.

2. TO instruction (Writing PLC data into BFM)

Use the TO instruction to write data to a buffer memory.

In a sequence program, use this instruction as follows:

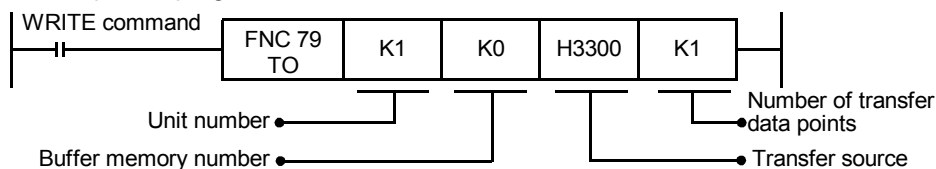

If the above program is created, 1 point of data (H3300) will be written to buffer memory BFM #0 of unit No.1.

5.3 Buffer Memory List (BFM)

4AD incorporates the following buffer memories.

→ For a detailed description of the buffer memory, refer to Section 5.4 and subsequent sections.

BFM number	Description	Setting range	Initial value	Data type	Reference
#0*1	Input mode setting for channels 1 to 4	*2	H0000 at delivery	Hexadecimal	Subsection 5.4.1
#1	Not used	-	-	-	-
#2	Averaging time units for channel 1	1 to 4095	K1	Decimal	Subsection 5.4.2
#3	Averaging time units for channel 2	1 to 4095	K1	Decimal	
#4	Averaging time units for channel 3	1 to 4095	K1	Decimal	
#5	Averaging time units for channel 4	1 to 4095	K1	Decimal	
#6	Channel-1 digital filter setting	0 to 1600	K0	Decimal	Subsection 5.4.3
#7	Channel-2 digital filter setting	0 to 1600	K0	Decimal	
#8	Channel-3 digital filter setting	0 to 1600	K0	Decimal	
#9	Channel-4 digital filter setting	0 to 1600	K0	Decimal	
#10	Channel-1 data (current data or average data)	-	-	Decimal	Subsection 5.4.4
#11	Channel-2 data (current data or average data)	-	-	Decimal	
#12	Channel-3 data (current data or average data)	-	-	Decimal	
#13	Channel-4 data (current data or average data)	-	-	Decimal	
#14 to #18	Not used	-	-	-	-
#19*1	Data change disable Disables adjustment of the following buffer memory locations: <ul style="list-style-type: none"> • Input mode specification (BFM #0) • Initialization function (BFM #20) • Input characteristics writing (BFM #21) • Convenient functions (BFM #22) • Offset data (BFM #41 to #44) • Gain data (BFM #51 to #54) • Automatic transfer-to data register specification (BFM #125 to #129) • Data history sampling time setting (BFM #198) 	To enable data change: K2080 To disable data change: Value other than K2080	K2080 at delivery	Decimal	Subsection 5.4.5
#20	Initialization function: Set "K1" in this buffer memory to perform initialization. At the completion of initialization, buffer memory will be automatically reset to "K0".	K0 or K1	K0	Decimal	Subsection 5.4.6
#21	Input characteristics writing: Write the input characteristics offset/gain value. At the completion of writing, buffer memory will be automatically reset to "H0000" (b0 to b3: OFF).	*3	H0000	Hexadecimal	Subsection 5.4.7

- *1. If power failure occurs, the EEPROM will retain its data.
- *2. To specify the input mode of each channel, set each digit using hexadecimal numbers 0 to 8 and F.
- *3. Use b0 to b3.

BFM number	Description	Setting range	Initial value	Data type	Reference	
#22*1	Convenient function setting: Convenient functions:Automatic send function, data addition, upper/lower limit detection, abrupt change detection, peak value holding	*2	H0000 at delivery	Hexadecimal	Subsection 5.4.8	
#23 to #25	Not used	-	-	-	-	
#26	Upper/lower limit value error status (Valid if b1 of BFM #22 is set to ON)	-	H0000	Hexadecimal	Subsection 5.4.9	
#27	Abrupt change detection status (Valid if b2 of BFM #22 is set to ON)	-	H0000	Hexadecimal	Subsection 5.4.10	
#28	Over-scale status	-	H0000	Hexadecimal	Subsection 5.4.11	
#29	Error status	-	H0000	Hexadecimal	Subsection 5.4.12	
#30	Model code K2080	-	K2080	Decimal	Subsection 5.4.13	
#31 to #40	Not used	-	-	-	-	
#41*1	Channel-1 offset data (Unit: mV or μ A)	BFM #21 will be used for writing data.	• Voltage input: -10000 to +9000*3 • Current input: -20000 to +17000*4	K0 at delivery	Decimal	Subsection 5.4.14
#42*1	Channel-2 offset data (Unit: mV or μ A)			K0 at delivery	Decimal	
#43*1	Channel-3 offset data (Unit: mV or μ A)			K0 at delivery	Decimal	
#44*1	Channel-4 offset data (Unit: mV or μ A)			K0 at delivery	Decimal	
#45 to #50	Not used	-	-	-	-	
#51*1	Channel-1 gain data (Unit: mV or μ A)	BFM #21 will be used for writing data.	• Voltage input: -9000 to +10000*3 • Current input: -17000 to +30000*4	K5000 at delivery	Decimal	Subsection 5.4.14
#52*1	Channel-2 gain data (Unit: mV or μ A)			K5000 at delivery	Decimal	
#53*1	Channel-3 gain data (Unit: mV or μ A)			K5000 at delivery	Decimal	
#54*1	Channel-4 gain data (Unit: mV or μ A)			K5000 at delivery	Decimal	
#55 to #60	Not used	-	-	-	-	
#61	Channel-1 addition data (Valid if b0 of BFM #22 is set to ON)	-16000 to +16000	K0	Decimal	Subsection 5.4.15	
#62	Channel-2 addition data (Valid if b0 of BFM #22 is set to ON)	-16000 to +16000	K0	Decimal		
#63	Channel-3 addition data (Valid if b0 of BFM #22 is set to ON)	-16000 to +16000	K0	Decimal		
#64	Channel-4 addition data (Valid if b0 of BFM #22 is set to ON)	-16000 to +16000	K0	Decimal		
#65 to #70	Not used	-	-	-	-	
#71	Channel-1 lower limit value error setting (Valid if b1 of BFM #22 is set to ON)	From minimum digital value in input range to upper limit value error setting value	Minimum digital value in input range	Decimal	Subsection 5.4.16	
#72	Channel-2 lower limit value error setting (Valid if b1 of BFM #22 is set to ON)		Minimum digital value in input range	Decimal		
#73	Channel-3 lower limit value error setting (Valid if b1 of BFM #22 is set to ON)		Minimum digital value in input range	Decimal		
#74	Channel-4 lower limit value error setting (Valid if b1 of BFM #22 is set to ON)		Minimum digital value in input range	Decimal		
#75 to #80	Not used	-	-	-	-	

- *1. If power failure occurs, the EEPROM will retain its data.
- *2. Use b0 to b7.
- *3. The offset and gain values should satisfy the following conditions: Gain value - Offset value \geq 1000
- *4. The offset and gain values should satisfy the following conditions: 30000 \geq Gain value - Offset value \geq 3000

BFM number	Description	Setting range	Initial value	Data type	Reference
#81	Channel-1 upper limit value error setting (Valid if b1 of BFM #22 is set to ON)	From lower limit value error setting value to maximum digital value in input range	Maximum digital value in input range	Decimal	Subsection 5.4.16
#82	Channel-2 upper limit value error setting (Valid if b1 of BFM #22 is set to ON)		Maximum digital value in input range	Decimal	
#83	Channel-3 upper limit value error setting (Valid if b1 of BFM #22 is set to ON)		Maximum digital value in input range	Decimal	
#84	Channel-4 upper limit value error setting (Valid if b1 of BFM #22 is set to ON)		Maximum digital value in input range	Decimal	
#85 to #90	Not used	-	-	-	-
#91	Channel-1 abrupt change detection value (Valid if b2 of BFM #22 is set to ON)	From 1 to 50% of full scale	5% of full scale	Decimal	Subsection 5.4.17
#92	Channel-2 abrupt change detection value (Valid if b2 of BFM #22 is set to ON)	From 1 to 50% of full scale	5% of full scale	Decimal	
#93	Channel-3 abrupt change detection value (Valid if b2 of BFM #22 is set to ON)	From 1 to 50% of full scale	5% of full scale	Decimal	
#94	Channel-4 abrupt change detection value (Valid if b2 of BFM #22 is set to ON)	From 1 to 50% of full scale	5% of full scale	Decimal	
#95 to #98	Not used	-	-	-	-
#99	Clear of upper/lower limit error data or abrupt change error data	*1	H0000	-	Subsection 5.4.18
#100	Not used	-	-	-	-
#101	Channel-1 minimum peak value (Valid if b3 of BFM #22 is set to ON)	-	-	Decimal	Subsection 5.4.19
#102	Channel-2 minimum peak value (Valid if b3 of BFM #22 is set to ON)	-	-	Decimal	
#103	Channel-3 minimum peak value (Valid if b3 of BFM #22 is set to ON)	-	-	Decimal	
#104	Channel-4 minimum peak value (Valid if b3 of BFM #22 is set to ON)	-	-	Decimal	
#105 to #108	Not used	-	-	-	-
#109	Minimum peak value resetting	*3	H0000	Hexadecimal	Subsection 5.4.20
#110	Not used	-	-	-	-
#111	Channel-1 maximum peak value (Valid if b3 of BFM #22 is set to ON)	-	-	Decimal	Subsection 5.4.19
#112	Channel-2 maximum peak value (Valid if b3 of BFM #22 is set to ON)	-	-	Decimal	
#113	Channel-3 maximum peak value (Valid if b3 of BFM #22 is set to ON)	-	-	Decimal	
#114	Channel-4 maximum peak value (Valid if b3 of BFM #22 is set to ON)	-	-	Decimal	
#115 to #118	Not used	-	-	-	-
#119	Maximum peak value resetting	*3	H0000	Hexadecimal	Subsection 5.4.20
#120 to #124	Not used	-	-	-	-
#125 ^{*2}	Peak values (Minimum: BFM #101 to #104 / Maximum: #111 to #114) automatic transfer to first data register specification (Valid if b4 of BFM #22 is set to ON / Occupies of 8 consecutive points)	0 to 7992	K200 at delivery	Decimal	Subsection 5.4.21

- *1. Use b0 to b2.
- *2. If power failure occurs, the EEPROM will retain its data.
- *3. Use b0 to b3.

A
Common Items

B
FX3U-4AD
FX3UC-4AD

C
FX3U-4AD-ADP

D
FX3G-2AD-BD

E
FX3U-4DA

F
FX3U-4DA-ADP

G
FX3G-1DA-BD

H
FX3U-3A-ADP

I
FX3U-4AD-PT-ADP

J
FX3U-4AD-PTW-ADP

BFM number	Description	Setting range	Initial value	Data type	Reference
#126*1	Upper/lower limit error status data (BFM #26) automatic transfer-to data register specification (Valid if b5 of BFM #22 is set to ON)	0 to 7999	K208 at delivery	Decimal	Subsection 5.4.22
#127*1	Abrupt change detection status data (BFM #27) automatic transfer-to data register specification (Valid if b6 of BFM #22 is set to ON)	0 to 7999	K209 at delivery	Decimal	Subsection 5.4.23
#128*1	Over-scale status data (BFM #28) automatic transfer-to data register specification (Valid if b7 of BFM #22 is set to ON)	0 to 7999	K210 at delivery	Decimal	Subsection 5.4.24
#129*1	Error status data (BFM #29) automatic transfer-to data register specification (Valid if b8 of BFM #22 is set to ON)	0 to 7999	K211 at delivery	Decimal	Subsection 5.4.25
#130 to #196	Not used	-	-	-	-
#197	Selection of cyclic data update function (function for data history)	*2	H0000	Hexadecimal	Subsection 5.4.26
#198*1	Data history sampling time setting (Unit: ms)	0 to 30000	K15000	Decimal	Subsection 5.4.27
#199	Data history resetting/stoppage	*3	H0000	Hexadecimal	Subsection 5.4.28
#200	Channel-1 data history (initial value)	-	K0	Decimal	Subsection 5.4.29
∧	∧	∧	∧	Decimal	
#1899	Channel-1 data history (1,700th value)	-	K0	Decimal	
#1900	Channel-2 data history (initial value)	-	K0	Decimal	
∧	∧	∧	∧	Decimal	
#3599	Channel-2 data history (1,700th value)	-	K0	Decimal	
#3600	Channel-3 data history (initial value)	-	K0	Decimal	
∧	∧	∧	∧	Decimal	
#5299	Channel-3 data history (1,700th value)	-	K0	Decimal	
#5300	Channel-4 data history (initial value)	-	K0	Decimal	
∧	∧	∧	∧	Decimal	
#6999	Channel-4 data history (1,700th value)	-	K0	Decimal	
#7000 to #8063	System area	-	-	-	-

- *1. If power failure occurs, the EEPROM will retain its data.
- *2. Use b0 to b3.
- *3. Use b0 to b3 and b8 to b11.

5.4 Buffer Memory Details

5.4.1 BFM #0: Input mode specification

Initial value (at delivery): H0000
 Numeric data type: Hexadecimal (H)

Specify the input modes of channel 1 to 4.
 4 hexadecimal digits are assigned to specify the input modes of the 4 channels.
 Change the value of each digit to change the input mode of each channel. 0 to 8 or F can be set for each digit.

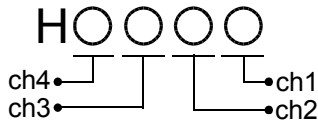

The different types of input modes are shown in the following table:

→ For a detailed description of input characteristics, refer to Section 2.4.

Set value [HEX]	Input mode	Analog input range	Digital output range
0	Voltage input mode	-10V to +10V	-32000 to +32000
1	Voltage input mode	-10V to +10V	-4000 to +4000
2*1	Voltage input Analog value direct indication mode	-10V to +10V	-10000 to +10000
3	Current input mode	4mA to 20mA	0 to 16000
4	Current input mode	4mA to 20mA	0 to 4000
5*1	Current input Analog value direct indication mode	4mA to 20mA	4000 to 20000
6	Current input mode	-20mA to +20mA	-16000 to +16000
7	Current input mode	-20mA to +20mA	-4000 to +4000
8*1	Current input Analog value direct indication mode	-20mA to +20mA	-20000 to +20000
9 to E	Setting not possible	-	-
F	Channel not used	-	-

*1. The offset/gain values cannot be changed.

1. Cautions regarding input mode setting

- If the input mode is set (changed), the analog input characteristics will be changed automatically. Furthermore, when the offset/gain value is changed, the characteristics can be set to the desired values. (The resolution cannot be changed.)
- If the analog value direct indication (*1) is specified, the offset/gain value cannot be changed.
- It takes approximately 5 seconds to determine the input mode. For this reason, after changing the input mode, be sure to wait for 5 seconds or more before writing other data.
- HFFFF (no channels used) cannot be set.

2. Caution regarding EEPROM writing

If data is written to BFM #0, #19, #21, #22, #125 to #129, or #198, the data will also be written to the 4AD EEPROM.

The maximum number of EEPROM rewrites is 10,000 times. Therefore, when creating a program, do not frequently write data to the above buffer memories (BFM).

5.4.2 BFM #2 to #5: Averaging time

Setting range: 1 to 4095
Initial value: K1
Numeric data type: Decimal (K)

To change the channel data type from the immediate data (channels 1 to 4: BFM #10 to #13) to the average data, set the desired averaging time (channels 1 to 4 : BFM #2 to 5).

The relation between the set averaging time and the corresponding operation is shown in the following table.

→ **For a detailed description of channel data update timing, refer to Subsection 5.4.4.**

Averaging time (BFM #2 to #5)	Channel data (BFM #10 to #13) type	Error descriptions
0 or less	Immediate data (Each time the A/D conversion is performed, the channel data will be updated.)	K0 will be set, and the averaging time setting error (b10 of BFM #29) will occur.
1 (initial value)	Immediate data (Each time the A/D conversion is performed, the channel data will be updated.)	-
2 to 400	Average data (Each time the A/D conversion is performed, the average value will be calculated and the channel data will be updated.)	-
401 to 4095	Average data (Each time the A/D conversion data reaches the averaging time, the average data will be calculated and the channel data will be updated.)	-
4096 or more	Average data (Each time the A/D conversion is performed, the channel data will be updated.)	4096 will be set, and the averaging time setting error (b10 of BFM #29) will occur.

1. Application

If the measurement signal contains comparatively reduced ripple noise, such as supply voltage frequency, averaging will result in obtaining of stable data.

2. Cautions regarding averaging time setting

- To use the averaging function, be sure to set the digital filter of the corresponding channel to "0". (Digital filter setting: BFM #6 to #9 for channels 1 to 4)
 To use the digital filter function, be sure to set the averaging time of the corresponding channel to "1". (Averaging time: BFM #2 to #5 for channels 1 to 4)
 If the averaging time is set to a value other than "1" and the digital filter (BFM #6 to #9 for channels 1 to 4) is set to a value other than "0", the digital filter setting error (b11 of BFM #29) will occur.
- If one of the channels uses the digital filter, the A/D conversion time will be set to 5 ms for all the channels.
- If the averaging time is out of the setting range, the averaging time setting error (b10 of BFM #29) will occur.
- If the averaging time is set, the data history function cannot be used.

5.4.3 BFM #6 to #9: Digital filter setting

Setting range: 0 to 1600
Initial value: K0
Numeric data type: Decimal (K)

To use the digital filter for channel data (BFM #10 to #13 for channels 1 to 4), set the digital filter value in the corresponding buffer memory (BFM #6 to #9 for channels 1 to 4).

→ For a detailed description of channel data update timing, refer to Subsection 5.4.4.

If the digital filter function is used, the relation between the analog input value and the set digital filter value or the digital output value (channel data) will be as follows:

- Digital filter value (BFM #6 to #9 for channels 1 to 4) > Fluctuation of analog signal (fluctuation width: less than 10 times of sampling)**
 If the fluctuation of the analog signal (input value) is less than the set digital filter value, the analog input value will be converted into a stabilized digital output value and stored in the corresponding buffer memory (BFM #10 to #13 for channels 1 to 4).
- Digital filter value (BFM #6 to #9 for channels 1 to 4) < Fluctuation of analog signal**
 If the fluctuation of the analog signal (input value) is more than the set digital filter value, the digital output value will follow the analog input value, and the digital output value equal to the analog input value will be stored in the corresponding buffer memory (BFM #10 to #13 for channels 1 to 4).

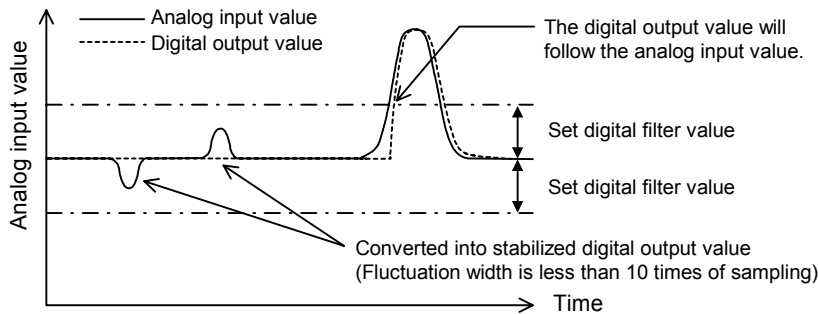

The relation between the set value and the corresponding operation is shown in the following table:

Set value	Operation
Less than 0	Disables the digital filter function. A setting error will occur (b11 of BFM #29 will be set to ON).
0	Disables the digital filter function.
1 to 1600	Enables the digital filter function.
1601 or more	Disables the digital filter function. A setting error will occur (b11 of BFM #29 will be set to ON).

1. Application

If the measurement signal contains steep spike noise, use the digital filter instead of the averaging function. The digital filter produces more stabilized data results.

2. Cautions regarding digital filter setting

- To use the digital filter function, be sure to set the averaging time of the corresponding channel to "1". (Averaging time: BFM #2 to #5 for channels 1 to 4) If the averaging time is set to a value other than "1" and the digital filter is set to a value other than "0", the digital filter setting error (b11 of BFM #29) will occur.
- If one of the channels uses the digital filter, the A/D conversion time will be set to 5 ms for all the channels.
- If the digital filter set value is not in the range from 0 to 1600, the digital filter setting error (b11 of BFM #29) will occur.

5.4.4 BFM #10 to #13: Channel data

Numeric data type: Decimal (K)

Use these buffer memories to store the A/D converted digital values.

The channel data (BFM #10 to #13 for channels 1 to 4) and the data update timing will depend on the set averaging time (BFM #2 to #5 for channels 1 to 4) or the digital filter setting condition (BFM #6 to #9 for channels 1 to 4) as shown in the following table.

- For a detailed description of the averaging time, refer to Subsection 5.4.2.
- For a detailed description of digital filter functions, refer to Subsection 5.4.3.

Averaging time (BFM #2 to #5)	Digital filter function (BFM #6 to #9)	Channel data (BFM #10 to #13) update timing	
		Channel data type	Update timing
0 or less	0 (The digital filter will not be used.)	Immediate data "0" will be set, and the averaging time setting error (b10 of BFM #29) will occur.	Each time the A/D conversion is performed, the data will be updated. The update timing will be as follows: Update time = 500μs^{*1} × Number of selected channels
	0 (The digital filter will not be used.)	Immediate data	
1	1 to 1600 (The digital filter will be used.)	Immediate data The digital filter function will be used.	Each time the A/D conversion is performed, the data will be updated. The update timing will be as follows: Update time = 5ms × Number of selected channels
	0 (The digital filter will not be used.)	Average data	Each time the A/D conversion is performed, the data will be updated. The update timing will be as follows: Update time = 500μs^{*1} × Number of selected channels
2 to 400	0 (The digital filter will not be used.)	Average data	Each time the A/D conversion is performed for the set averaging time, the data will be updated. The update timing will be as follows: Update time = 500μs^{*1} × Number of selected channels × Averaging time
401 to 4095		Average data	
4096 or more		Average data "4096" will be set, and the averaging time setting error (b10 of BFM #29) will occur.	

- *1. "500 μ s" represents the A/D conversion time.
 However, if one of the channels uses the digital filter function, the A/D conversion time will be 5 ms for all the channels.

5.4.5 BFM #19: Data change disable

Setting range: K2080, or value other than K2080
Initial value (at delivery): K2080
Numeric data type: Decimal (K)

Disables adjustment of the following BFM:

- Input mode specification (BFM #0)
- Input characteristics writing (BFM #21)
- Offset data (BFM #41 to #44)
- Automatic transfer-to data register specification (BFM #125 to #129)
- Data history sampling time setting (BFM #198)
- Initialization function (BFM #20)
- Convenient functions (BFM #22)
- Gain data (BFM #51 to #54)

Set the value of BFM #19 (Data change disable) as follows:

Set value	Description
K2080	Data change enabled.
Value other than K2080	Data change disabled.

1. Caution regarding EEPROM writing

If data is written to BFM #0, #19, #21, #22, #125 to #129, or #198, the data will also be written to the 4AD EEPROM.

→ For a detailed description of caution regarding EEPROM writing, refer to Subsection 5.4.1.

5.4.6 BFM #20: Initialization function (resetting to factory default status)

Setting range: K0 or K1
Initial value: K0
Numeric data type: Decimal (K)

Use this function to initialize all data in BFM #0 to #6999, to the factory default status.

Set value	Description
K0	Normal
K1	Initializes all data

Set "K1" to initialize all data. When initialization is complete, "K0" will be set automatically.

1. Caution regarding initialization function setting

- It takes approximately 5 seconds to initialize all the data.
- Priority is given to BFM #19 which prevents a data from being changed. To initialize, set K2080 in BFM #19.

5.4.7 BFM #21: Input characteristics writing

Initial value: H0000
Numeric data type: Hexadecimal (H)

Channel numbers are assigned to the 4 lower bits of BFM #21. If any of these bits are turned on, the offset data (BFM #41 to #44) and gain data (BFM #51 to #54) of the corresponding channel will be written to the internal memory (EEPROM). When written to the internal memory, the data will become valid.

1. BFM #21 bits channel number assignment

Bit No.	Description
b0	Channel-1 offset data (BFM #41) and gain data (BFM #51) writing
b1	Channel-2 offset data (BFM #42) and gain data (BFM #52) writing
b2	Channel-3 offset data (BFM #43) and gain data (BFM #53) writing
b3	Channel-4 offset data (BFM #44) and gain data (BFM #54) writing
b4 to b15	Not used.

The WRITE command can be given to two or more channels at the same time. (Set "H000F" to write all channel data to the EEPROM.) When writing is complete, "H0000" (b0 to b3: OFF) will be set automatically.

5.4.8 BFM #22: Convenient function setting

Initial value: H0000
Numeric data type: Hexadecimal (H)

Turn on each bit (b0 to b8) of BFM #22 to enable the function assigned to each bit (refer to the following table). Turn off each bit to disable the function of each bit.

1. Function assigned to each bit of BFM #22

Bit No.	Function	Description	Reference
b0	Data addition function	The channel data (BFM #10 to #13), peak data (BFM #101 to #104, #111 to #114), and data history (BFM #200 to #6999) will be subject to change (the addition data (BFM #61 to #64) will be added to the measurement data). When setting the lower limit error data (BFM #71 to #74) or the upper limit error data (BFM #81 to #84), add the addition data (BFM #61 to #64) to the error data to be set.	Subsection 5.4.15
b1	Upper/lower limit detection function	If the A/D conversion data of a channel is outside the range set by the lower limit error data (BFM #71 to #74) and the upper limit error data (BFM #81 to #84), the result will be written to BFM #26 as the upper/lower limit error status data.	Subsection 5.4.16
b2	Abrupt change detection function	When channel data (BFM #10 to #13) is updated, if the difference between the previous value and the new value is larger than the set abrupt change detection value (value set in BFM #91 to #94), the result will be written to BFM #27 as the abrupt change detection status data.	Subsection 5.4.17
b3	Peak value holding function	The minimum value of channel data written to BFM #10 to #13 will be written to BFM #101 to #104 as the minimum peak value, and the maximum value of channel data written to BFM #10 to #13 will be written to BFM #111 to #114 as the maximum peak value.	Subsection 5.4.19
b4	Peak value automatic transfer function	If the automatic transfer-to first data register is specified in BFM #125, the minimum peak value (BFM #101 to #104) and the maximum peak value (BFM #111 to #114) will be automatically written to the specified data registers (8 points (registers) starting from the first data register specified).	Subsection 5.4.19 Subsection 5.4.21
b5	Upper/lower limit error status data automatic transfer function	If the upper/lower limit error status data automatic transfer-to data register is specified in BFM #126, the upper/lower limit error status data (BFM #26) will be automatically written to the specified data register.	Subsection 5.4.16 Subsection 5.4.22
b6	Abrupt change detection status data automatic transfer function	If the abrupt change detection status data automatic transfer-to data register is specified in BFM #127, the abrupt change detection status data (BFM #27) will be automatically written to the specified data register.	Subsection 5.4.17 Subsection 5.4.23
b7	Over-scale status data automatic transfer function	If the over-scale status data automatic transfer-to data register is specified in BFM #128, the over-scale status data (BFM #28) will be automatically written to the specified data register.	Subsection 5.4.24
b8	Error status data automatic transfer function	If the error status data automatic transfer to data register is specified in BFM #129, the error status data (BFM #29) will be automatically written to the specified data register.	Subsection 5.4.25
b9 to b15	-	Not used.	-

2. Caution regarding convenient function setting

- Even if the data addition function is used, the value before adding the addition data (BFM #61 to #64) will be checked to detect the over-scale error.
- To use the peak value automatic transfer function (b4 of BFM #22), be sure to enable the peak value holding function (b3 of BFM #22).
- To use the upper/lower limit error status data automatic transfer function (b5 of BFM #22), be sure to enable the upper/lower limit value detection function (b1 of BFM #22).
- To use the abrupt change detection status data automatic transfer function (b6 of BFM #22), be sure to enable the abrupt change detection function (b2 of BFM #22).

3. Caution regarding EEPROM writing

If data is written to BFM #0, #19, #21, #22, #125 to #129, or #198, the data will also be written to the 4AD EEPROM.

→ For a detailed description of caution regarding EEPROM writing, refer to Subsection 5.4.1.

A
Common Items

B
FX3U-4AD
FX3UC-4AD

C
FX3U-4AD-ADP
FX3UC-4AD

D
FX3G-2AD-BD

E
FX3U-4DA

F
FX3U-4DA-ADP

G
FX3G-1DA-BD

H
FX3U-3A-ADP

I
FX3U-4AD-PT
-ADP

J
FX3U-4AD-PTW
-ADP

5.4.9 BFM #26: Upper/lower limit error status

Initial value: H0000
Numeric data type: Hexadecimal (H)

If channel data (BFM #10 to #13) is out of the range set by the lower limit error data (BFM #71 to #74) and the upper limit error data (BFM #81 to #84), the following operation will be performed:

- If "channel data < lower limit error set value":
 The lower limit error bit will turn on.
 - If "channel data > upper limit error set value":
 The upper limit error bit will turn on.
- For a detailed description of upper/lower limit error status data resetting, refer to Subsection 5.4.18.

1. BFM #26 bit assignment

The upper and lower limit error values of each channel are assigned as shown in the following table:

Bit No.	Channel number	Description
b0	ch1	Lower limit error value
b1		Upper limit error value
b2	ch2	Lower limit error value
b3		Upper limit error value
b4	ch3	Lower limit error value
b5		Upper limit error value
b6	ch4	Lower limit error value
b7		Upper limit error value
b8 to b15	Not used.	

2. Cautions regarding use of upper/lower limit error status data

- To use the upper/lower limit error status data, be sure to turn on the upper/lower limit detection function (b1 of BFM #22).
- Perform one of the following operations to turn off the previously turned on bit:
 - Turn the power off and on.
 - Turn on b0 or b1 of BFM #99 to reset the upper/lower limit error status.
 - Write "H0000" in BFM #26 as the upper/lower limit error status data.
- Even if an error is detected, channel data (BFM #10 to #13) will be continuously updated.

3. Upper/lower limit error status data automatic transfer function (b5 of BFM #22)

If the upper/lower limit error status data automatic transfer-to data register is specified in BFM #126, the data in BFM #26 can be transferred to the specified data register.

When the upper/lower error is detected, data will be automatically transferred from the 4AD to the PLC. For this reason, the PLC does not need the program for reading data, and the scanning time of the PLC can be shortened.

□ : Represents a numeric value.

Convenient function setting	Automatic data transfer function		
	Transfer-from buffer memory		Transfer-to data register specification (BFM #126: K□)
BFM #22 b1:ON BFM #22 b5:ON	BFM #26	→	D□

5.4.10 BFM #27: Abrupt change detection status

Initial value: H0000
 Numeric data type: Hexadecimal (H)

When channel data (BFM #10 to #13) is updated, if the difference between the previous value and the new value is larger than the set abrupt change detection value (value set in BFM #91 to #94), the following operation will be performed:

- If "(new value) - (previous value) > (abrupt change detection value)":
 The "+" direction bit will turn on.
- If "(previous value) - (new value) > (abrupt change detection value)":
 The "-" direction bit will turn on.

→ For a detailed description of abrupt change detection status data resetting, refer to Subsection 5.4.18.

1. Assignment of each bit of BFM #27

For the abrupt change detection function of each channel, the "+" and "-" directions are assigned as shown in the following table:

Bit No.	Channel number	Description
b0	ch1	"-" direction for abrupt change detection
b1		"+" direction for abrupt change detection
b2	ch2	"-" direction for abrupt change detection
b3		"+" direction for abrupt change detection
b4	ch3	"-" direction for abrupt change detection
b5		"+" direction for abrupt change detection
b6	ch4	"-" direction for abrupt change detection
b7		"+" direction for abrupt change detection
b8 to b15	Not used.	

2. Caution regarding use of abrupt change detection status data

- To use the abrupt change status data, be sure to turn on the abrupt change detection function (b2 of BFM #22).
- Perform one of the following operations to turn off the previously turned on bit:
 - Turn the power off and on.
 - Turn on b2 of BFM #99 to reset the abrupt change detection error status.
 - Write "H0000" in BFM #27 as the abrupt change detection status data.
- Even if abrupt change is detected, channel data (BFM #10 to #13) will be continuously updated.

3. Abrupt change detection status data automatic transfer function (b6 of BFM #22)

If the abrupt change detection status data automatic transfer-to data register is specified in BFM #127, the data in BFM #27 can be transferred to the specified data register.

When abrupt change is detected, data will be automatically transferred from the 4AD to the PLC. For this reason, the PLC does not need any program for reading the data, and the scan time of the PLC can be shortened.

□ : Represents a numeric value.

Convenient function setting	Automatic data transfer function		
	Transfer-from memory		Transfer-to data register specification (BFM #127: K□)
ON = Valid BFM #22 b2:ON BFM #22 b6:ON	BFM #27	→	D□

5.4.11 BFM #28: Over-scale status

Initial value: H0000
Numeric data type: Hexadecimal (H)

If the input analog value is out of the A/D conversion range, the following operation will be performed:

- If "(analog input value) < (lower limit value in A/D conversion range)":
 The over-scale lower limit bit will turn on.
- If "(analog input value) > (upper limit value in A/D conversion range)":
 The over-scale upper limit bit will turn on.

1. A/D conversion range

Input type	A/D conversion range
Voltage input	-10.2V to +10.2V
Current input	-20.4mA to +20.4mA

2. Assignment of each bit of BFM #28

Bit No.	Channel number	Description
b0	ch1	Over-scale (lower limit)
b1		Over-scale (upper limit)
b2	ch2	Over-scale (lower limit)
b3		Over-scale (upper limit)
b4	ch3	Over-scale (lower limit)
b5		Over-scale (upper limit)
b6	ch4	Over-scale (lower limit)
b7		Over-scale (upper limit)
b8 to b15	Not used.	

3. Caution regarding use of over-scale status data

- Perform one of the following operations to turn off the previously turned on bit:
 - Turn the power off and on.
 - Write "H0000" in BFM #28 as the over-scale status data.
- Even if over scale is detected, channel data (BFM #10 to #13) will continuously be updated.

4. Over-scale status data automatic transfer function (b7 of BFM #22)

If the over-scale status data automatic transfer-to data register is specified in BFM #128, the data in BFM #28 can be transferred to the specified data register.

When over-scale is detected, data will be automatically transferred from the 4AD to the PLC. For this reason, the PLC does not need any program for reading the data, and the scan time of the PLC can be shortened.

□ : Represents a numeric value.

Convenient function setting	Automatic data transfer function		
	Transfer-from memory		Transfer-to data register specification (BFM #128: K□)
ON = Valid	BFM #28	→	D□

5.4.12 BFM #29: Error status

Initial value: H0000
 Numeric data type: Hexadecimal (H)

Error data is assigned to the bits of BFM #29.

1. BFM #29 Bit Assignment

Bit No.	Item	Description
b0	Error detection	If any bits between b2 and b4 are turned on, b0 will turn on.
b1	-	-
b2	Power supply error	The 24 V power is not supplied properly. Check the wiring condition or the voltage supplied.
b3	Hardware error	FX3U-4AD/FX3UC-4AD may be defective. Please contact the nearest Mitsubishi Electric distributor office.
b4	A/D conversion error	The A/D conversion value is abnormal. Check the over-scale status data (BFM #28) to localize the error channel.
b5	-	-
b6	BFM reading/writing impossible	If change in the input characteristics is started, this bit will turn on. If this bit (b6) is on, A/D conversion data cannot be read out correctly.
b7	-	-
b8	Data setting error detection	If any bits between b10 and b15 are turned on, b8 will turn on.
b9	-	-
b10	Averaging time setting error	The averaging time (BFM #2 to #5) is not set correctly. Set the averaging time again in the range from 1 to 4095.
b11	Digital filter setting error	The digital filter value (BFM #6 to #9) is not set correctly. Set the digital filter value again in the range from 0 to 1600.
b12	Abrupt change detection value setting error	The abrupt change detection value (BFM #91 to #94) is not set correctly. Correctly set the value again.
b13	Upper/lower limit error detection value setting error	The lower limit error detection value (BFM #71 to #74) or the upper limit error detection value (BFM #81 to #84) is not set correctly. Correctly set the value again.
b14	-	-
b15	Addition data setting error	The addition data (BFM #61 to #64) is not set correctly. Set the addition data again in the range from -16000 to +16000.

2. Caution regarding error status

If the error cause is eliminated, the error bit will turn off.
 Do not directly write "H0000" in BFM #29 using a sequence program.

3. Error status data automatic transfer function (b8 of BFM #22)

If the error status data automatic transfer-to data register is specified in BFM #129, the data in BFM #29 can be transferred to the specified data register.

When an error is detected, data will be automatically transferred from 4AD to the PLC. For this reason, the PLC does not need any program for reading the data, and the scan time of the PLC can be shortened.

: Represents a numeric value.

Convenient function setting	Automatic data transfer function		
	Transfer-from memory		Transfer-to data register specification (BFM #129: K <input type="checkbox"/>)
BFM #22 b8:ON	BFM #29	→	D <input type="checkbox"/>

5.4.13 BFM #30: Model code

Initial value: K2080
Numeric data type: Decimal (K)

"K2080" (fixed value) is stored as the model code.

5.4.14 BFM #41 to #44: Offset data / BFM #51 to #54: Gain data

Setting range: See below.
Initial value: See below.
Numeric data type: Decimal (K)

If the input mode is specified in BFM #0, the offset data and the gain data of each channel will be automatically stored. The initial offset data and gain data are set for each mode as shown in the following table:

- Offset data: Analog input value when the digital value is "0" (reference offset value)
- Gain data: Analog input value when the digital value is equal to the reference gain value (The reference gain value depends on the set input mode.)

1. Reference offset/gain value and initial value set at delivery

Input mode (BFM #0)		Offset (Channels 1 to 4: BFM #41 to #44)		Gain (Channels 1 to 4: BFM #51 to #54)	
Set value	Description	Reference value	Initial value	Reference value	Initial value
0	Voltage input (-10V to +10V:-32000 to +32000)	0	0mV	16000	5000mV
1	Voltage input (-10V to +10V:-4000 to +4000)	0	0mV	2000	5000mV
2	Voltage input Analog value direct indication mode (-10V to +10V:-10000 to +10000)	0 (Data change impossible)	0mV (Data change impossible)	5000 (Data change impossible)	5000mV (Data change impossible)
3	Current input (4mA to 20mA:0 to 16000)	0	4000μA	16000	20000μA
4	Current input (4mA to 20mA:0 to 4000)	0	4000μA	4000	20000μA
5	Current input Analog value direct indication mode (4mA to 20mA:4000 to 20000)	4000 (Data change impossible)	4000μA (Data change impossible)	20000 (Data change impossible)	20000μA (Data change impossible)
6	Current input (-20mA to +20mA:-16000 to +16000)	0	0μA	16000	20000μA
7	Current input (-20mA to +20mA:-4000 to +4000)	0	0μA	4000	20000μA
8	Current input Analog value direct indication mode (-20mA to +20mA:-20000 to +20000)	0 (Data change impossible)	0μA (Data change impossible)	20000 (Data change impossible)	20000μA (Data change impossible)

2. Offset/gain data change

Set offset data and gain data to change the input characteristics.

The offset and gain data can be set for each channel. If the voltage input mode is set, write the offset and gain data in mV. If the current input mode is set, write the offset and gain data in μA .

To change the offset data or gain data, turn on the corresponding bit of BFM #21 (buffer memory for input characteristics writing).

The data setting range is shown in the following table:

	Voltage input (mV)	Current input (μA)
Offset data	-10000 to +9000* ¹	-20000 to +17000* ²
Gain data	-9000 to +10000* ¹	-17000 to +30000* ²

*1. The offset and gain values should meet the following condition:

$$\text{Gain value} - \text{Offset value} \geq 1000$$

*2. The offset and gain values should meet the following condition:

$$30000 \geq \text{Gain value} - \text{Offset value} \geq 3000$$

3. Cautions regarding offset/gain data change

- If the analog value direct indication mode is used, the input characteristics cannot be changed.
- Even if the input characteristics are changed, the actual valid input range will not be changed: from -10V to +10V for the voltage input mode, and from -20mA to +20mA for the current input mode.
- Even if the input characteristics are changed, the resolution will not increase.
 → For a detailed description of input characteristics change, refer to Chapter 6.

5.4.15 BFM #61 to #64: Addition data

Setting range: -16000 to +16000

Initial value: K0

Numeric data type: Decimal (K)

If the addition data (BFM #61 to #64) is set, the set data will be added before storing the channel data (BFM #10 to #13), peak data (BFM #101 to #104, BFM #111 to #114), or data history (BFM #200 to #6999).

1. Cautions regarding addition data setting

- To use the addition data, be sure to turn on the data addition function (b0 of BFM #22).
- When setting the lower limit error data (BFM #71 to #74) or the upper limit error data (BFM #81 to #84), add the addition data (BFM #61 to #64) to the error data to be set.

A	Common Items
B	FX3U-4AD FX3UC-4AD
C	FX3U-4AD-ADP
D	FX3G-2AD-BD
E	FX3U-4DA
F	FX3U-4DA-ADP
G	FX3G-1DA-BD
H	FX3U-3A-ADP
I	FX3U-4AD-PT -ADP
J	FX3U-4AD-PTW -ADP

5.4.16 BFM #71 to #74: Lower limit error setting / BFM #81 to #84: Upper limit error setting

Setting range: See below.
Initial value: See below.
Numeric data type: Decimal (K)

Set the upper/lower limit error data so that the upper/lower limit error status (BFM #26) can be detected.
 The data setting range depends on the input mode set in BFM #0.
 The following table shows the data setting range for each input mode:

Input mode (BFM #0)		Setting range	Initial value	
Set value	Description		Lower limit value (Channels 1 to 4: BFM #71 to #74)	Upper limit value (Channels 1 to 4: BFM #81 to #84)
0	Voltage input (-10V to +10V: -32000 to +32000)	-32768 to +32767	-32768	32767
1	Voltage input (-10V to +10V: -4000 to +4000)	-4095 to +4095	-4095	4095
2	Voltage input Analog value direct indication mode (-10V to +10V: -10000 to +10000)	-10200 to +10200	-10200	10200
3	Current input (4mA to 20mA: 0 to 16000)	-1 to +16383	-1	16383
4	Current input (4mA to 20mA: 0 to 4000)	-1 to +4095	-1	4095
5	Current input Analog value direct indication mode (4mA to 20mA: 4000 to 20000)	3999 to 20400	3999	20400
6	Current input (-20mA to +20mA: -16000 to +16000)	-16384 to +16383	-16384	16383
7	Current input (-20mA to +20mA: -4000 to +4000)	-4096 to +4095	-4096	4095
8	Current input Analog value direct indication mode (-20mA to +20mA: -20000 to +20000)	-20400 to +20400	-20400	20400

1. Cautions regarding upper/lower limit error setting

- To use the set upper/lower limit error data, be sure to turn on the upper/lower limit error detection function (b1 of BFM #22).
- To use the data addition function (b0 of BFM #22) together with this function, be sure to add the addition data (channels 1 to 4: BFM #61 to #64) to the upper/lower limit values to be set. In addition, observe the data setting range.

5.4.17 BFM #91 to #94: Abrupt change detection value setting

Setting range: See below.
Initial value: See below.
Numeric data type: Decimal (K)

When channel data (BFM #10 to #13) is updated, if the difference between the previous value and the new value is larger than the set abrupt change detection value (value set in BFM #91 to #94), the system will judge that the channel data is changed abruptly.

The result of abrupt change detection will be written to BFM #27 as the abrupt change detection status data. The abrupt change detection value setting range depends on the set input mode (BFM #0) as shown in the following table:

Input mode (BFM #0)		Setting range	Initial value
Set value	Description		
0	Voltage input (-10V to +10V:-32000 to +32000)	1 to 32767	3200
1	Voltage input (-10V to +10V:-4000 to +4000)	1 to 4095	400
2	Voltage input Analog value direct indication mode (-10V to +10V:-10000 to +10000)	1 to 10000	1000
3	Current input (4mA to 20mA:0 to 16000)	1 to 8191	800
4	Current input (4mA to 20mA:0 to 4000)	1 to 2047	200
5	Current input Analog value direct indication mode (4mA to 20mA:4000 to 20000)	1 to 8191	800
6	Current input (-20mA to +20mA:-16000 to +16000)	1 to 16383	1600
7	Current input (-20mA to +20mA:-4000 to +4000)	1 to 4095	400
8	Current input Analog value direct indication mode (-20mA to +20mA:-20000 to +20000)	1 to 20000	2000

1. Caution regarding abrupt change detection value setting

To use the abrupt change detection value, be sure to turn on the abrupt change detection function (b2 of BFM #22).

A	Common Items
B	FX3U-4AD FX3UC-4AD
C	FX3U-4AD-ADP
D	FX3G-2AD-BD
E	FX3U-4DA
F	FX3U-4DA-ADP
G	FX3G-1DA-BD
H	FX3U-3A-ADP
I	FX3U-4AD-PT -ADP
J	FX3U-4AD-PTW -ADP

5.4.18 BFM #99: Clearance of upper/lower limit error data and abrupt change detection data

Initial value: H0000
 Numeric data type: Hexadecimal (H)

Three error data clearance commands (lower limit error data clearance command, upper limit error data clearance command, and abrupt change detection data clearance command) are respectively assigned to the 3 lower bits of BFM #99.

Turning on each bit (batch turning on for all channels) will reset the corresponding error status flag (#26 or #27 of BFM).

1. BFM #99 bits command assignment

Bit No.	Description	Buffer memory to be cleared
b0	Lower limit error data clearance command	BFM #26
b1	Upper limit error data clearance command	
b2	Abrupt change detection data clearance command	BFM #27
b3 to b15	Not used.	-

Two or more data clearance commands can be turned on at the same time.

2. Operation after resetting BFM #26, #27

Each bit will turn off automatically.

5.4.19 BFM #101 to #104: Minimum peak value / BFM #111 to #114: Maximum peak value

Numeric data type: Decimal (K)

The minimum channel data (channels 1 to 4) value written to BFM #10 to #13 will be written to BFM #101 to #104 as the minimum peak value, and the maximum channel data value will be written to BFM #111 to #114 as the maximum peak value.

1. Caution regarding peak value

To use the minimum peak value and the maximum peak value, be sure to turn on the peak value holding function (b3 of BFM #22).

Note:

- If the data addition function (b0 of BFM #22) is used together with this function, the addition data will be added to the measurement data.
- If the value holding function is not used, the peak value will be "K0".

2. Peak value automatic transfer function (b4 of BFM #22)

If the automatic transfer-to first data register is specified in BFM #125, the minimum peak value and the maximum peak value will be automatically written to the specified data registers (8 points (registers) starting from the first data register specified).

When the peak value is updated, data will be automatically transferred from the 4AD to the PLC. For this reason, the PLC does not need any program for reading the data, and the scan time of the PLC can be shortened.

□ : Represents a numeric value.

Convenient function setting	Automatic data transfer function		
ON = Valid	Transfer-from buffer memory		Transfer-to data register specification (BFM #125: K□) (8 points (registers) starting from the specified data register)
BFM #22 b4:ON BFM #22 b3:ON	BFM #101 to 104 BFM #111 to 114	→	D□ to D□+3 D□+4 to D□+7

5.4.20 BFM #109: Minimum peak value resetting / BFM #119: Maximum peak value resetting

Initial value: H0000
Numeric data type: Hexadecimal (H)

BFM #109 can reset the minimum peak value (BFM #101 to #104), and BFM #119 can reset the maximum peak value (BFM #111 to #114).

Channel numbers are assigned to the bits of BFM #109 and #119 to specify the channel to be subject to peak value resetting.

Turn on each bit to reset the peak value of the corresponding channel.

1. BFM #109/#119 bits Channel number assignment

Bit No.	Description	
	BFM #109	BFM #119
b0	Channel-1 minimum peak value (BFM #101) resetting	Channel-1 maximum peak value (BFM #111) resetting
b1	Channel-2 minimum peak value (BFM #102) resetting	Channel-2 maximum peak value (BFM #112) resetting
b2	Channel-3 minimum peak value (BFM #103) resetting	Channel-3 maximum peak value (BFM #113) resetting
b3	Channel-4 minimum peak value (BFM #104) resetting	Channel-4 maximum peak value (BFM #114) resetting
b4 to b15	Not used.	

Two or more bits can be turned on at a time.

5.4.21 BFM #125: Peak value automatic transfer to first data register specification

Setting range: 0 to 7992
Initial value (at delivery) : K200
Numeric data type: Decimal (K)

If the automatic transfer to first data register is specified in BFM #125, the minimum peak value (BFM #101 to #104) and the maximum peak value (BFM #111 to #114) will be automatically transferred to the specified data registers (8 points (registers) starting from the first data register specified).

When the peak value is updated, data will be automatically transferred from the 4AD to the PLC. For this reason, the PLC does not need any program for reading the data, and the scan time of the PLC can be shortened.

→ For a detailed description of the minimum peak value (BFM #101 to #104) and the maximum peak value (BFM #111 to #114), refer to Subsection 5.4.19.

1. If "BFM #125 = K200 (initial value)"

Data will be transferred to D200 to D207 (8 points).

Specified data register	Description
D200	Channel-1 minimum peak value (BFM #101)
D201	Channel-2 minimum peak value (BFM #102)
D202	Channel-3 minimum peak value (BFM #103)
D203	Channel-4 minimum peak value (BFM #104)
D204	Channel-1 maximum peak value (BFM #111)
D205	Channel-2 maximum peak value (BFM #112)
D206	Channel-3 maximum peak value (BFM #113)
D207	Channel-4 maximum peak value (BFM #114)

2. Caution regarding peak value automatic transfer-to first data register specification

- If data registers are already specified for the other automatic transfer functions, do not specify the same data registers.
- Be sure to turn on the peak value automatic transfer function (b4 of BFM #22) and the peak value holding function (b3 of BFM #22).
- The data written to BFM #125 will be retained in the EEPROM.

3. Caution regarding EEPROM writing

If data is written to BFM #0, #19, #21, #22, #125 to #129, or #198, the data will also be written to the 4AD EEPROM.

→ For a detailed description of caution regarding EEPROM writing, refer to Subsection 5.4.1.

5.4.22 BFM #126: Upper/lower error status data automatic transfer-to data register specification

Setting range: 0 to 7999
Initial value (at delivery) : K208
Numeric data type: Decimal (K)

Use this function to automatically transfer the upper/lower limit error status data (BFM #26) to the data register specified in BFM #126.

When the upper/lower limit error is detected, data will be automatically transferred from the 4AD to the PLC. For this reason, the PLC does not need any program for reading the data, and the scanning time of the PLC can be shortened.

→ For a detailed description of the upper/lower limit error status data (BFM #26), refer to Subsection 5.4.9.

1. If "BFM #126 = K208 (initial value)"

Specified data register	Description
D208	Upper/lower limit error status data in BFM #26

2. Cautions regarding upper/lower limit error status data automatic transfer-to data register specification

- If a data register is already specified for the other automatic transfer functions, do not specify the same data register.
- Be sure to turn on the upper/lower limit error status data automatic transfer function (b5 of BFM #22) and the upper/lower limit detection function (b1 of BFM #22).
- The data written to BFM #126 will be retained in the EEPROM.

3. Caution regarding EEPROM writing

If data is written to BFM #0, #19, #21, #22, #125 to #129, or #198, the data will also be written to the 4AD EEPROM.

→ For a detailed description of caution regarding EEPROM writing, refer to Subsection 5.4.1.

5.4.23 BFM #127: Abrupt change detection status data automatic transfer-to data register specification

Setting range: 0 to 7999
Initial value (at delivery) : K209
Numeric data type: Decimal (K)

Use this function to automatically transfer the abrupt change detection status data (BFM #27) to the data register specified in BFM #127.

When abrupt change is detected, data will be automatically transferred from the 4AD to the PLC. For this reason, the PLC does not need any program for reading the data, and the scan time of the PLC can be shortened.

→ For a detailed description of the abrupt change detection status data (BFM #27), refer to Subsection 5.4.10.

1. If "BFM #127 = K209 (initial value)"

Specified data register	Description
D209	Abrupt change detection status data in BFM #27

2. Caution regarding abrupt change detection status data automatic transfer to data register specification

- If a data register is already specified for the other automatic transfer functions, do not specify the same data register.
- Be sure to turn on the abrupt change detection status data automatic transfer function (b6 of BFM #22) and the abrupt change detection function (b2 of BFM #22).
- The data written to BFM #127 will be retained in the EEPROM.

3. Caution regarding EEPROM writing

If data is written to BFM #0, #19, #21, #22, #125 to #129, or #198, the data will also be written to the 4AD EEPROM.

→ For a detailed description of caution regarding EEPROM writing, refer to Subsection 5.4.1.

A
Common Items

B
FX3U-4AD
FX3UC-4AD

C
FX3U-4AD-ADP

D
FX3G-2AD-BD

E
FX3U-4DA

F
FX3U-4DA-ADP

G
FX3G-1DA-BD

H
FX3U-3A-ADP

I
FX3U-4AD-PT
-ADP

J
FX3U-4AD-PTW
-ADP

5.4.24 BFM #128: Over-scale status data automatic transfer-to data register specification

Setting range: 0 to 7999
Initial value (at delivery) : K210
Numeric data type: Decimal (K)

Use this function to automatically transfer the over-scale status data (BFM #28) to the data register specified in BFM #128.

When over-scale is detected, data will be automatically transferred from the 4AD to the PLC. For this reason, the PLC does not need any program for reading the data, and the scan time of the PLC can be shortened.

→ For a detailed description of the over-scale status data (BFM #28), refer to Subsection 5.4.11.

1. If "BFM #128 = K210 (initial value)"

Specified data register	Description
D210	Over-scale status data in BFM #28

2. Cautions regarding over-scale status data automatic transfer-to data register specification

- If a data register is already specified for the other automatic transfer functions, do not specify the same data register.
- Be sure to turn on the over-scale status data automatic transfer function (b7 of BFM #22).
- The data written to BFM #128 will be retained in the EEPROM.

3. Caution regarding EEPROM writing

If data is written to BFM #0, #19, #21, #22, #125 to #129, or #198, the data will also be written to the 4AD EEPROM.

→ For a detailed description of caution regarding EEPROM writing, refer to Subsection 5.4.1.

5.4.25 BFM #129: Error status data automatic transfer-to data register specification

Setting range: 0 to 7999
Initial value (at delivery) : K211
Numeric data type: Decimal (K)

Use this function to automatically transfer the error status data (BFM #29) to the data register specified in BFM #129.

When an error is detected, data will be automatically transferred from the 4AD to the PLC. For this reason, the PLC does not need any program for reading the data, and the scan time of the PLC can be shortened.

→ For a detailed description of the error status data (BFM #29), refer to Subsection 5.4.12.

1. If "BFM #129 = K211 (initial value)"

Specified data register	Description
D211	Error status data in BFM #29

2. Cautions regarding error status data automatic transfer-to data register specification

- If a data register is already specified for the other automatic transfer functions, do not specify the same data register.
- Be sure to turn on the error status data automatic transfer function (b8 of BFM #22).
- The data written to BFM #129 will be retained in the EEPROM.

3. Caution regarding EEPROM writing

If data is written to BFM #0, #19, #21, #22, #125 to #129, or #198, the data will also be written to the 4AD EEPROM.

→ For a detailed description of caution regarding EEPROM writing, refer to Subsection 5.4.1.

5.4.26 BFM #197: Selection of cyclic data update function (function for data history)

Initial value: H0000
 Numeric data type: Hexadecimal (H)

Use this function to update the data history in BFM #200 to #6999.

Channel numbers are respectively assigned to the 4 lower bits of BFM #197. Turn each bit on or off to select the data history update function.

ON: If a bit is turned on, the corresponding data will be stored in the buffer memories in the order of the smallest BFM number to the largest BFM number, but when 1,700 points of data are stored, data will be then overwritten in the buffer memories starting from the smallest BFM numbers.

OFF: If a bit is turned off, the corresponding data will be stored in the buffer memories in the order of the smallest BFM number to the largest BFM number, but when 1,700 points of data are stored, data storage will stop.

1. Channel number assignment to each bit of BFM #197

Bit No.	Description	History data stored in
b0	Selection of channel-1 data update function	BFM #200 to #1899, 1,700 points
b1	Selection of channel-2 data update function	BFM #1900 to #3599, 1,700 points
b2	Selection of channel-3 data update function	BFM #3600 to #5299, 1,700 points
b3	Selection of channel-4 data update function	BFM #5300 to #6999, 1,700 points
b4 to b15	Not used.	-

5.4.27 BFM #198: Data history sampling time setting

Setting range: 0 to 30000
 Initial value (at delivery) : K15000
 Numeric data type: Decimal (K)

Use this function to set the data history sampling time.

If one of the channels uses the digital filter function, set a multiple of 5.

1. Sampling cycle

As shown in the following table, the sampling cycle depends on whether the digital filter function is used.

Whether digital filter function is used	Value set in BFM #198	Sampling cycle
None of the channels use the digital filter function.	0	0.5 ms × number of selected channels (number of channels using the digital filter function)
	1 or more	Set value (ms) in BFM #198 × number of selected channels (number of channels using the digital filter function)
One or more channels use the digital filter function.	9 or less	5 ms × number of selected channels (number of channels using the digital filter function)
	10 or more	Set value (ms) ^{*1} in BFM #198 × number of selected channels (number of channels using the digital filter function)

*1. Only multiples of 5 are valid.
 (If any value from 10 to 14 is set, the sampling cycle will be 10 ms. If any value from 15 to 19 is set, the sampling cycle will be 15 ms.)

2. Caution regarding use of data history function

If the averaging time is set, the data history function cannot be used.

3. Caution regarding EEPROM writing

If data is written to BFM #0, #19, #21, #22, #125 to #129, or #198, the data will also be written to the 4AD EEPROM.

→ For a detailed description of cautions regarding EEPROM writing, refer to Subsection 5.4.1.

5.4.28 BFM #199: Data history resetting/stoppage

Initial value: H0000
Numeric data type: Hexadecimal (H)

The data history resetting function and the data history stoppage function are assigned to the bits of BFM #199.

1. Data history resetting function (b0 to b3)

The sampled history data can be reset for each channel.

Turn on a bit to reset all the history data (1st to 1,700th) of the corresponding channel. (Note that two or more bits can be turned on at a time.)

When the data reset is complete, the corresponding bit will turn off automatically.

2. Data history stoppage function (b8 to b11)

Data sampling can be temporarily stopped for each channel.

Turn on a bit to temporarily stop sampling history data for the corresponding channel. (Note that two or more bits can be turned on at a time.)

Turn off the bit to restart sampling of history data.

3. Function assignment to each bit of BFM #199

Bit No.	Channel number	Description
b0	ch1	Data history resetting function
b1	ch2	
b2	ch3	
b3	ch4	
b4 to b7	Not used.	
b8	ch1	Data history stoppage function
b9	ch2	
b10	ch3	
b11	ch4	
b12 to b15	Not used.	

4. Caution regarding data history resetting

- When a bit is turned on, the corresponding data history will be reset.

5.4.29 BFM #200 to #6999: Data history

Initial value: K0
 Numeric data type: Decimal (K)

Use this function to sample the A/D conversion data of each channel and to write the sampled data to the buffer memories.

The 4AD can sample up to 1,700 points of A/D conversion data of each channel at the sampling cycle specified in BFM #198, and can store the sampled data as history data in the buffer memories as shown in the following table. Buffer memories are assigned to the 4 channels as shown in the following table, and data is stored in the buffer memories in the order of the smallest BFM number to the largest BFM number.

Use BFM #199 to stop or reset the data history.

Number of data samples	BFM number			
	ch1	ch2	ch3	ch4
1st	#200	#1900	#3600	#5300
2nd	#201	#1901	#3601	#5301
3rd	#202	#1902	#3602	#5302
⋮	⋮	⋮	⋮	⋮
1,700th	#1899	#3599	#5299	#6999

1. Caution regarding data history reading

If a large amount of history data is collectively read out to the PLC main unit using the FROM instruction, the watchdog timer error may occur in the PLC main unit. Therefore, when programming, separate the history data and then read it out using the FROM instruction. Set WDT (watchdog timer refresh) instruction between the separated data.

A	Common Items
B	FX3U-4AD FX3UC-4AD
C	FX3U-4AD-ADP
D	FX3G-2AD-BD
E	FX3U-4DA
F	FX3U-4DA-ADP
G	FX3G-1DA-BD
H	FX3U-3A-ADP
I	FX3U-4AD-PT -ADP
J	FX3U-4AD-PTW -ADP

6. Changing Input Characteristics

For the 4AD, the standard input characteristics are provided for each input mode (BFM #0) at the time of factory shipment.

Changing the offset data (BFM #41 to #44) or gain data (BFM #51 to #54), however, can change the input characteristics of each channel. This chapter describes how to change the input characteristics.

6.1 Procedure for Changing Input Characteristics

1 Determine the input mode (BFM #0)

Determine the optimum input mode (BFM #0) for the selected channels and the voltage/current specifications.

Set value (HEX)	Input mode	Analog input range	Digital output range
0	Voltage input mode	-10V to +10V	-32000 to +32000
1	Voltage input mode	-10V to +10V	-4000 to +4000
2	Voltage input analog value direct indication mode	The offset and the gain cannot be adjusted.	
3	Current input mode	4mA to 20mA	0 to 16000
4	Current input mode	4mA to 20mA	0 to 4000
5	Current input analog value direct indication mode	The offset and the gain cannot be adjusted.	
6	Current input mode	-20mA to +20mA	-16000 to +16000
7	Current input mode	-20mA to +20mA	-4000 to +4000
8	Current input analog value direct indication mode	The offset and the gain cannot be adjusted.	
9 to E	Not used.	-	-
F	Channel not used	-	-

Example: Enter "HFF00" in BFM #0 to set input mode 0 for channels 1 and 2 and prevent use channels 3 and 4.

Caution regarding data setting:

- If a channel is set to the value "2", "5", "8" or "F", the input characteristics of the channel cannot be changed.
- Set the optimum input mode for the analog signal to be input.

2 Determine the input characteristics to be changed.

Determine the digital value to be output according to the input voltage/current.

Example: To output digital values in the range from 0 to 32000 by inputting the voltage in the range from 1V DC to 5V DC:

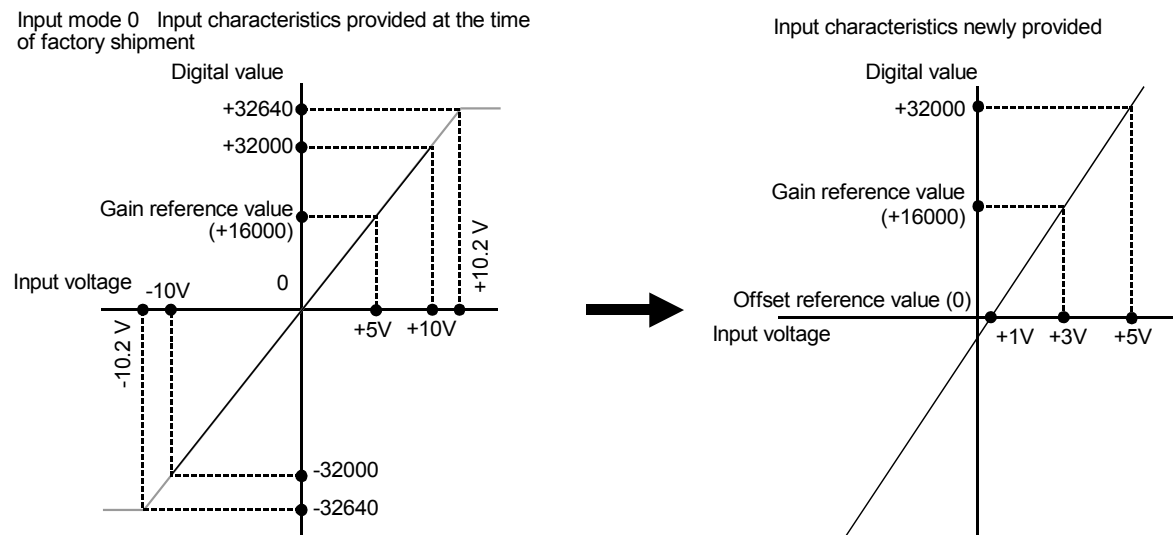

3 Determine the offset data.

Determine the analog input value (offset data) for digital output value of "0".

Set the analog input value in mV for the voltage input mode, and set the analog input value in μA for the current input mode.

Example: To set the offset value of 1 V, set 1,000 mV.

→ For a detailed description of offset data, refer to Subsection 5.4.14.

4 Determine the gain data.

Determine the analog input value so that the digital output value is equal to the gain reference value of each input mode.

The following table shows the gain reference value of each input mode:

Numeric value	Input mode	Analog input range	Gain standard value	Initial value
0	Voltage input mode	-10V to +10V	16000	5000mV
1	Voltage input mode	-10V to +10V	2000	5000mV
3	Current input mode	4mA to 20mA	16000	20000 μA
4	Current input mode	4mA to 20mA	4000	20000 μA
6	Current input mode	-20mA to +20mA	16000	20000 μA
7	Current input mode	-20mA to +20mA	4000	20000 μA

Set the analog input value in mV for the voltage input mode, and set the analog input value in μA for the current input mode.

Example: To set the gain value of 3 V, set 3000 mV.

→ For a detailed description of gain data, refer to Subsection 5.4.14.

5 Create a sequence program.

To change the input characteristics, write the offset data (BFM #41 to #44) and the gain data (BFM #51 to #54) in the sequence program, and then turn on the corresponding bit of BFM #21 for the corresponding channel. The following example shows a program for the unit number 0.

Example: Program for changing the input characteristics of channels 1 and 2 (For FX3U, FX3UC Series PLCs):

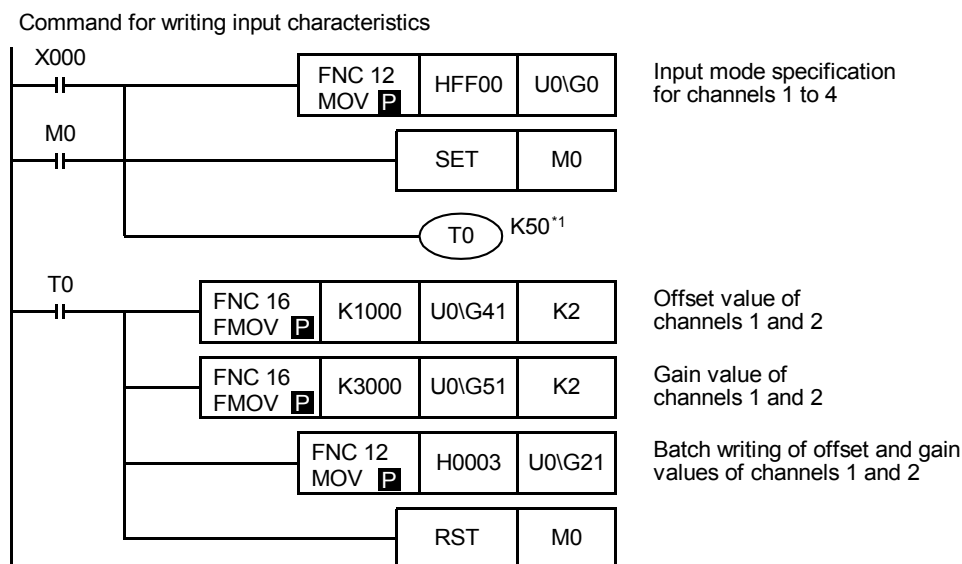

- *1. It takes approximately 5 seconds to change the input mode (BFM #0). This is because all the set values should be changed.
 After changing the input mode, be sure to wait for 5 seconds or more before setting other data.

The input characteristics of each channel can be written in BFM #21. It is also possible to perform batch writing of input characteristics for two or more channels.

6 Transfer the sequence program to change the input characteristics.

Transfer the sequence program, and start the PLC.

Start the PLC, and turn on the command (X000) to write the input characteristics. In approx. 5 seconds, the offset data and the gain data will be written.

Since the offset data and the gain data are stored in the 4AD EEPROM, it is possible to delete the sequence program.

7 Read out the analog data to check the data.

Create the following program to check the stored data (For FX3U, FX3UC Series PLCs):

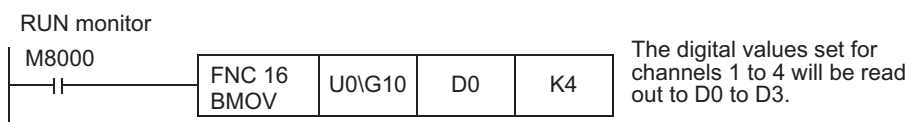

→ If data is not stored properly, refer to Chapter 8 "Troubleshooting".

7. Examples of Practical Programs

Use the functions incorporated in the 4AD to create practical programs. This chapter describes the examples of practical programs.

- Program that uses the averaging time
- Program that uses convenient functions
- Program that uses the data history function
- Program that initializes 4AD (to the factory default status)

7.1 Program That Uses Averaging Time

This section describes a program that uses the analog data averaging time input to the 4AD or the digital filter function of the 4AD.

1. Conditions

The sequence program described in this section is created under the following conditions.

- 1) System configuration
The FX3U-4AD (unit No.0) should be connected to the FX3U Series PLC.
- 2) Input mode
Channels 1 and 2 should be set to mode 0 (voltage input, -10V to +10V → -32000 to +32000).
Channels 3 and 4 should be set to mode 3 (current input, 4mA to 20mA → 0 to 16000).
- 3) Averaging time
For channels 1 to 4, the averaging time should be set to "10".
- 4) Digital filter function
For channels 1 to 4, the digital filter function should be disabled (default).
- 5) Device assignment

Device	Description
D0	A/D converted digital value for channel 1
D1	A/D converted digital value for channel 2
D2	A/D converted digital value for channel 3
D3	A/D converted digital value for channel 4

2. Example of sequence program

- For FX3U, FX3UC Series PLCs

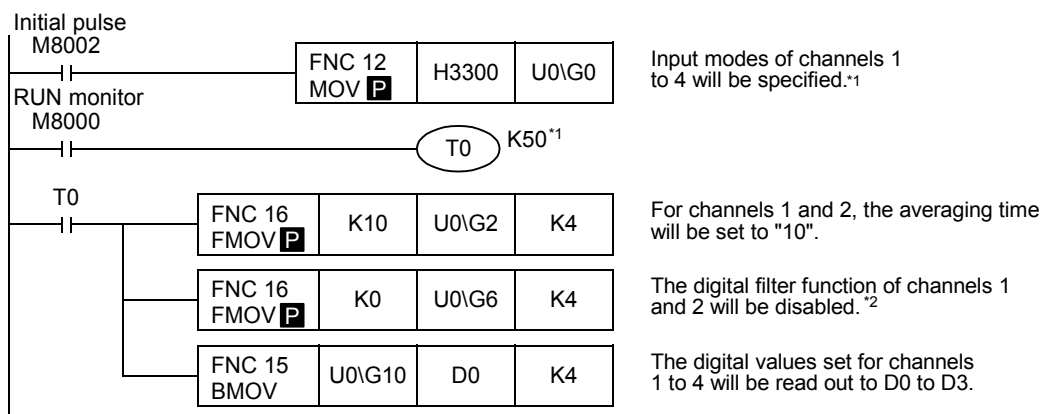

- *1. After setting the input mode, set the data writing time (waiting time) to 5 seconds or more for each setting.
The specified input mode will be retained even if power failure occurs. After specifying the input mode, if the same input mode is used, it is not necessary to set the input mode and waiting time (T0 K50).
- *2. To use the default value set for the digital filter function, it is not necessary to set the digital filter function in the sequence program.

- For FX3G, FX3U, FX3UC Series PLCs

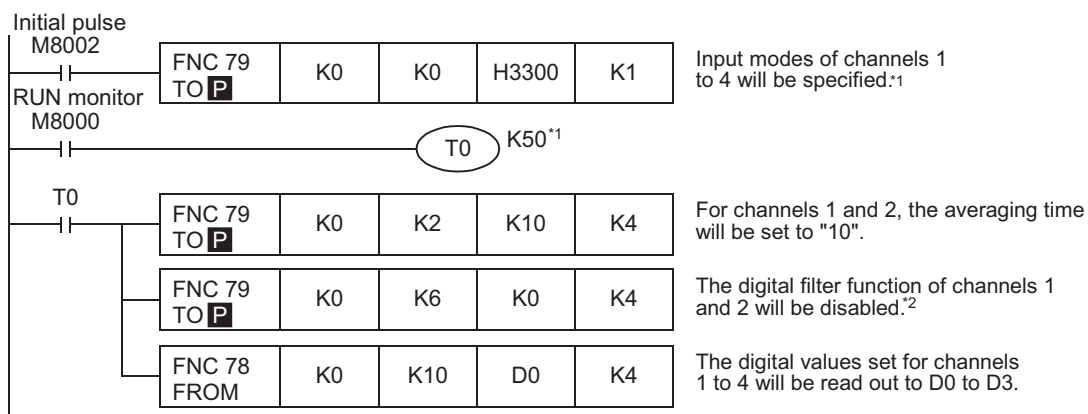

- *1. After setting the input mode, set the data writing time (waiting time) to 5 seconds or more for each setting.
 The specified input mode will be retained even if power failure occurs. After specifying the input mode, if the same input mode is used, it is not necessary to set the input mode and waiting time (T0 K50).
- *2. To use the default value set for the digital filter function, it is not necessary to set the digital filter function in the sequence program.

7.2 Program That Uses Convenient Functions

This section describes a program that uses the 4AD convenient functions (BFM #22).

1. Conditions

The sequence program described in this section is created under the following conditions.

- 1) System configuration
 The FX3U-4AD (unit No.0) should be connected to the FX3U Series PLC.
- 2) Input mode
 Channels 1 and 2 should be set to mode 0 (voltage input, -10V to +10V → -32000 to +32000).
 Channels 3 and 4 should be set to mode 3 (current input, 4mA to 20mA → 0 to 16000).
- 3) Averaging time
 For all the channels, the averaging time should be set to "1" (default).
 (To use the default value, it is not necessary to set the averaging time in the sequence program.)
- 4) Digital filter function
 For all channels, the digital filter function should be disabled (default).
 (To use the default value, it is not necessary to set the digital filter function in the sequence program.)
- 5) Convenient functions
 The upper/lower limit detection function, upper/lower limit error status data automatic transfer function, over-scale status data automatic transfer function, and error status data automatic transfer function should be used.
- 6) Device assignment

Device		Description
Input	X000	Clearance of upper/lower limit error data
	X001	Clearance of over-scale data
Output	Y000	Output of channel-1 lower limit error data
	Y001	Output of channel-1 upper limit error data
	Y002	Output of channel-2 lower limit error data
	Y003	Output of channel-2 upper limit error data
	Y004	Output of channel-3 lower limit error data
	Y005	Output of channel-3 upper limit error data
	Y006	Output of channel-4 lower limit error data
	Y007	Output of channel-4 upper limit error data
	Y010	Output of channel-1 over-scale (lower limit) data
	Y011	Output of channel-1 over-scale (upper limit) data
	Y012	Output of channel-2 over-scale (lower limit) data
	Y013	Output of channel-2 over-scale (upper limit) data
	Y014	Output of channel-3 over-scale (lower limit) data
	Y015	Output of channel-3 over-scale (upper limit) data
	Y016	Output of channel-4 over-scale (lower limit) data
	Y017	Output of channel-4 over-scale (upper limit) data
	Y20	Output of error detection signal
	Y21	Output of setting error detection signal
	D0	A/D converted digital value of channel 1
	D1	A/D converted digital value of channel 2
D2	A/D converted digital value of channel 3	
D3	A/D converted digital value of channel 4	
D100	Upper/lower limit error status data automatic transfer-to data register	
D101	Over-scale status data automatic transfer-to data register	
D102	Error status data automatic transfer-to data register	

2. Example of sequence program

- For FX3U, FX3UC Series PLCs

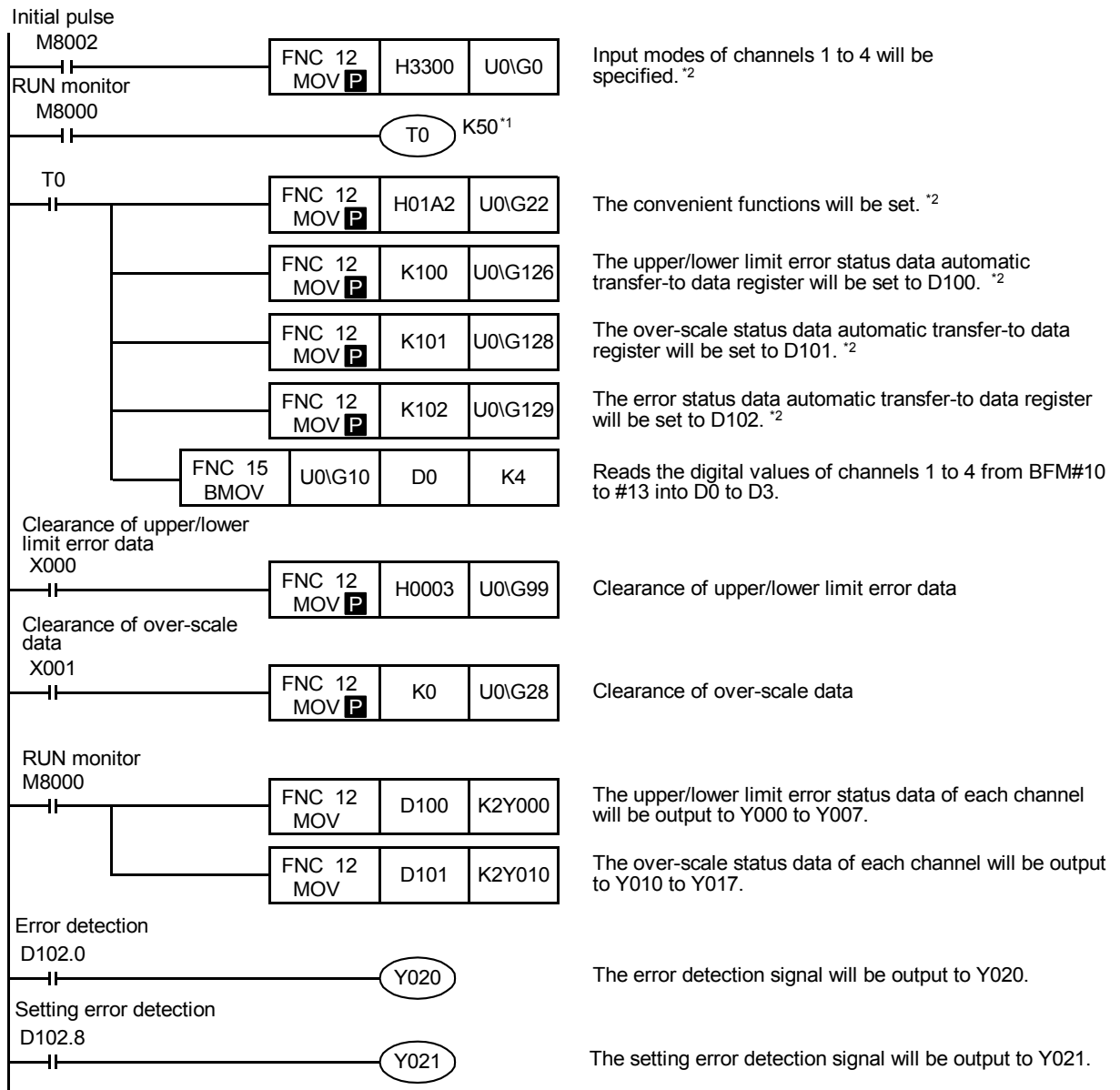

- *1. After setting the input mode, set the data writing time (waiting time) to 5 seconds or more for each setting.
 After this, if the same input mode is used, it is not necessary to set the input mode and waiting time (T0 K50) again.
- *2. The set input mode, convenient functions, upper/lower limit error status data automatic transfer-to data register number, over-scale status data automatic transfer-to data register number, and error status data automatic transfer-to data register number are retained in the 4AD EEPROM. For this reason, even if the sequence program is deleted, the previously set functions will still be valid.

- For FX3G, FX3U, FX3UC Series PLCs

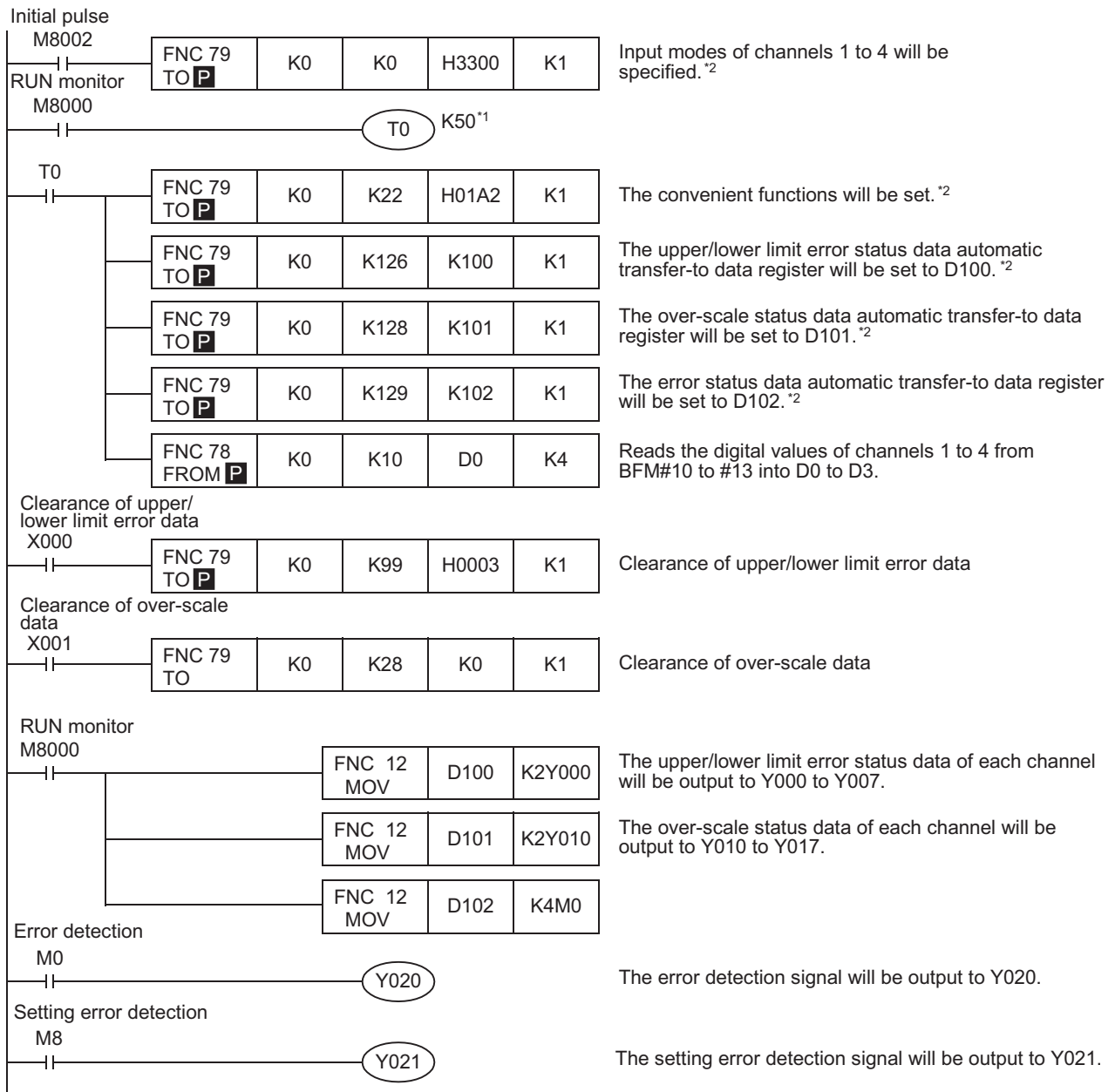

- *1. After setting the input mode, set the data writing time (waiting time) to 5 seconds or more for each setting. After this, if the same input mode is used, it is not necessary to set the input mode and waiting time (T0 K50) again.
- *2. The set input mode, convenient functions, upper/lower limit error status data automatic transfer-to data register number, over-scale status data automatic transfer-to data register number, and error status data automatic transfer-to data register number are retained in the 4AD EEPROM. For this reason, even if the sequence program is deleted, the previously set functions will still be valid.

7.3 Program That Uses Data History Function

This section describes a program that uses the data history function of the 4AD.

1. Conditions

The sequence program described in this section is created under the following functions.

- 1) System configuration
 The FX3U-4AD (unit No.0) should be connected to the FX3U Series PLC.
- 2) Input mode
 Channels 1 and 2 should be set to mode 0 (voltage input, -10V to +10V → -32000 to +32000).
 Channels 3 and 4 should be set to mode 3 (current input, 4mA to 20mA → 0 to 16000).
- 3) Averaging time
 For all the channels, the averaging time should be set to "1" (default).
 (To use the default value, it is not necessary to set the averaging time in the sequence program.)
- 4) Digital filter function
 For all channels, the digital filter function should be disabled (default).
 (To use the default value, it is not necessary to set the digital filter function in the sequence program.)
- 5) Data history function
 For all channels, the data sampling time should be set to 100 ms.
 The sampling cycle should be $100 \text{ ms} \times 4$ (number of selected channels) = 400 ms.
 For all channels, data will be sampled 100 times, and the sampled data will be stored as data history in the data registers.
- 6) Device assignment

Device		Description
Input	X000	Clearance of data history
	X001	Temporarily stoppage of data history
Data register	D0	A/D converted digital value of channel 1
	D1	A/D converted digital value of channel 2
	D2	A/D converted digital value of channel 3
	D3	A/D converted digital value of channel 4
	D100 to D199	Channel-1 data history(100 data samples)
	D200 to D299	Channel-2 data history(100 data samples)
	D300 to D399	Channel-3 data history(100 data samples)
	D400 to D499	Channel-4 data history(100 data samples)

2. Example of sequence program

- For FX3U, FX3UC Series PLCs

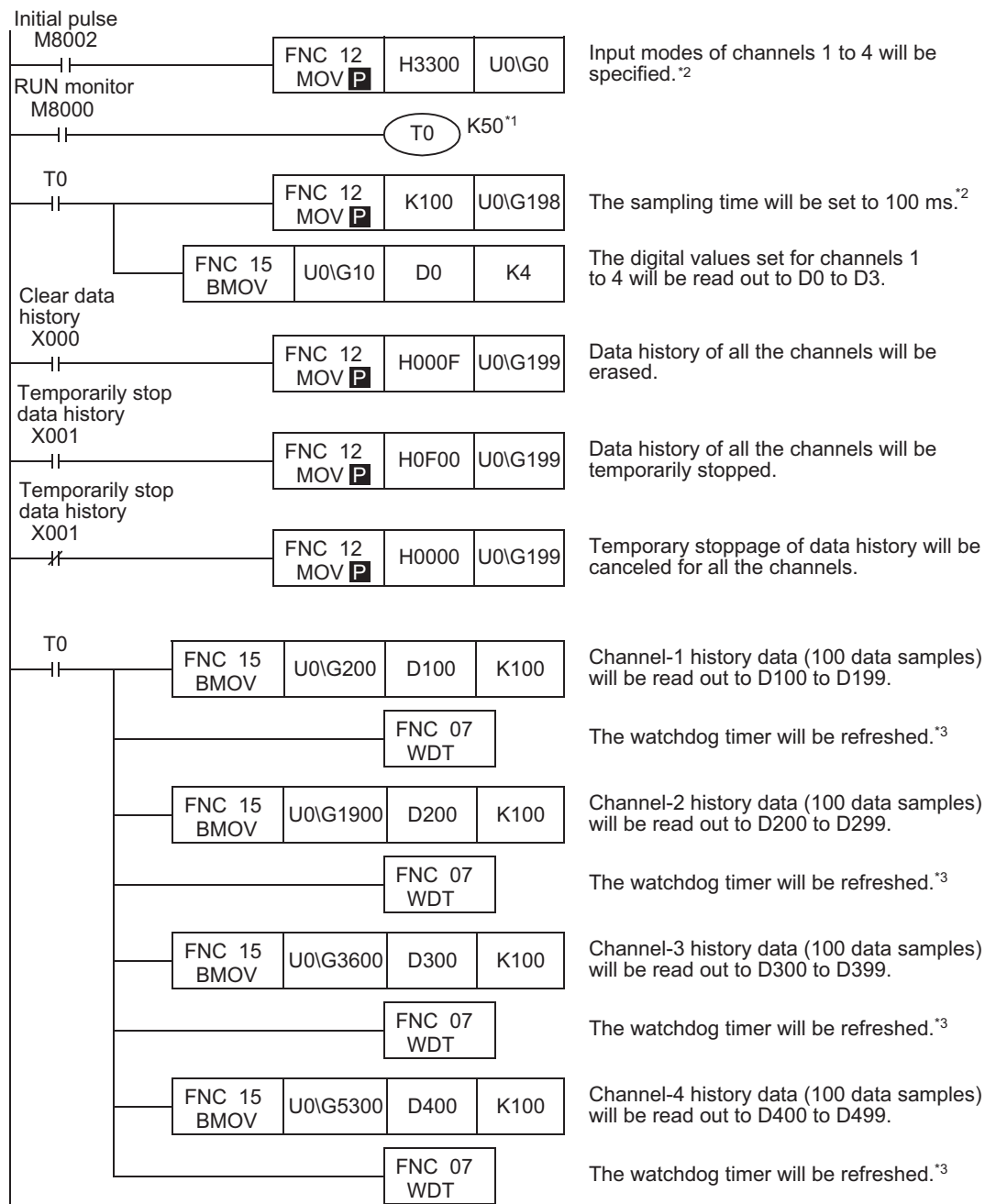

- *1. After setting the input mode, set the data writing time (waiting time) to 5 seconds or more for each setting.
 After this, if the same input mode is used, it is not necessary to set the input mode and waiting time (T0 K50) again.
- *2. The set input mode and the sampling time are retained in the 4AD EEPROM. Therefore, even if the sequence program is deleted, the previously set functions will still be valid.
- *3. If a large amount of history data is read out, the scan time of the PLC will be become longer. If the scan time exceeds 200 ms, the CPU error indicator lamp will illuminate, and the PLC will stop.
 Insert WDT instruction (watchdog timer refresh) between BMOV instructions.

- For FX3G, FX3U, FX3UC Series PLCs

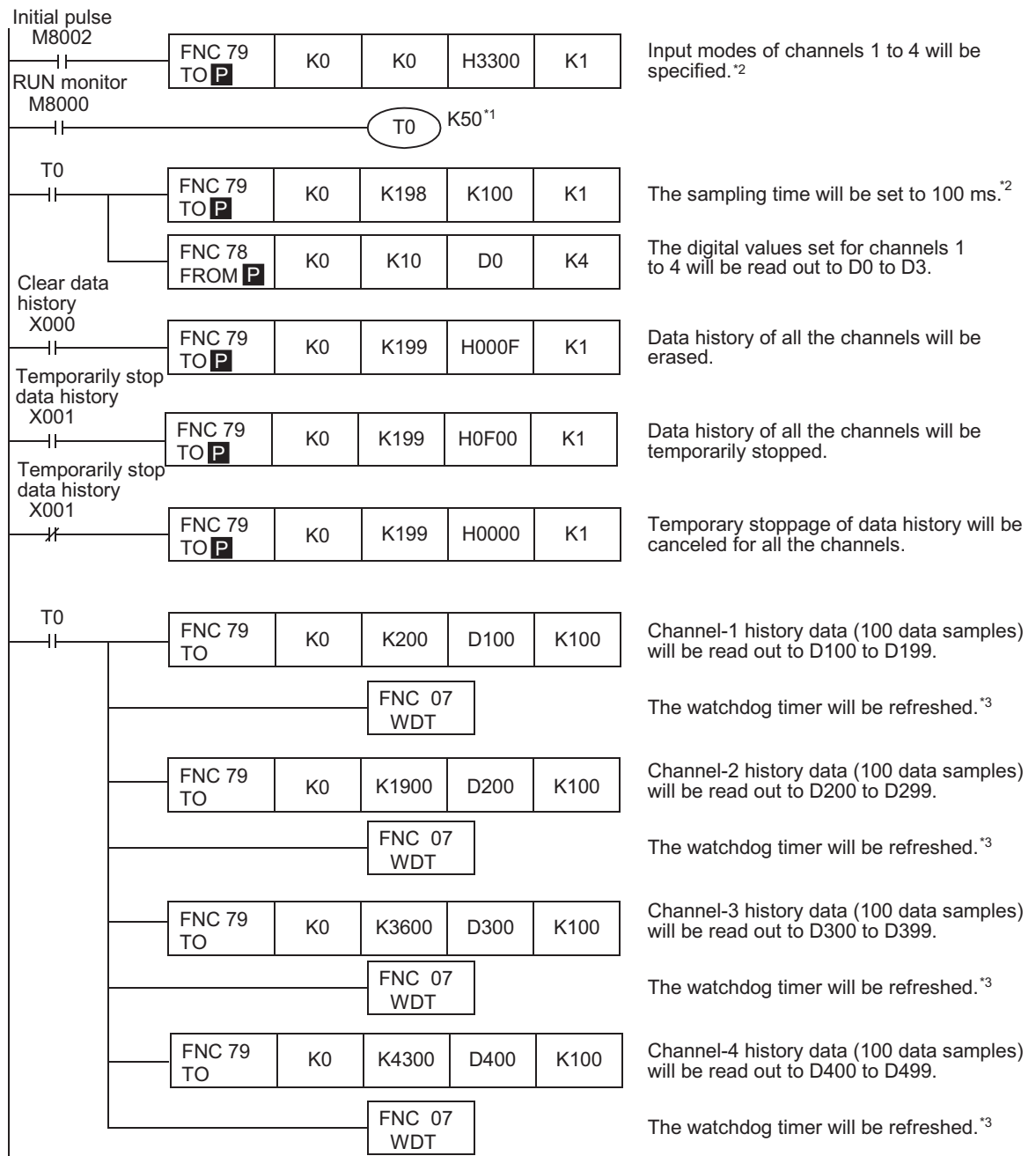

- After setting the input mode, set the data writing time (waiting time) to 5 seconds or more for each setting.
 After this, if the same input mode is used, it is not necessary to set the input mode and waiting time (T0 K50) again.
- The set input mode and the sampling time are retained in the 4AD EEPROM. Therefore, even if the sequence program is deleted, the previously set functions will still be valid.
- If a large amount of history data is read out, the scan time of the PLC will become longer. If the scan time exceeds 200 ms, the CPU error indicator lamp will illuminate, and the PLC will stop. Insert WDT instruction (watchdog timer refresh) between BMOV instructions.

7.4 Initialization Program for 4AD (Factory Default)

Execution of the following program will reset the input mode (BFM #0), offset data (BFM #41 to #44), gain data (BFM #51 to #54), etc. to the factory default status.

1. Conditions

The sequence program described in this section runs under the following conditions.

- 1) System configuration
 The FX3U-4AD (unit No.0) should be connected to the FX3U Series PLC.
- 2) Device assignment

Device	Description
X000	4AD initialization command

2. Example of sequence program

- For FX3U, FX3UC Series PLCs

4AD initialization command

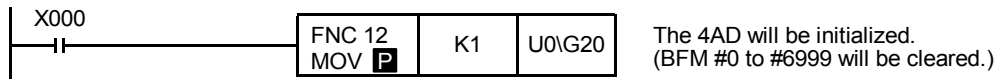

- For FX3G, FX3U, FX3UC Series PLCs

4AD initialization command

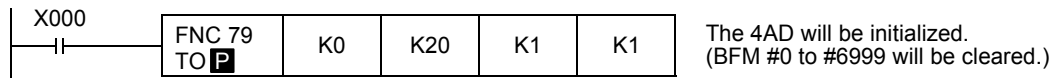

3. Cautions

- It takes approximately 5 seconds to complete initialization.
 Do not write any data to the buffer memory in this time.
- When initialization is complete, the value of BFM #20 will be reset to "K0".
- Priority is given to the data change disable (BFM #19). To initialize, write K2080 to BFM #19.

A	Common Items
B	FX3U-4AD FX3UC-4AD
C	FX3U-4AD-ADP
D	FX3G-2AD-BD
E	FX3U-4DA
F	FX3U-4DA-ADP
G	FX3G-1DA-BD
H	FX3U-3A-ADP
I	FX3U-4AD-PT -ADP
J	FX3U-4AD-PTW -ADP

8. Troubleshooting

This chapter describes troubleshooting methods and error codes.

If the A/D conversion data is not input, or if the proper digital value is not input, check the following items:

- PLC version number
- Wiring
- Program
- Error status

8.1 PLC Version Number Check

Verify that the PLC being used is of the following version or later.

FX3U-4AD

Compatible PLC	Version number
FX3U Series PLC	Ver. 2.20 or later
FX3UC Series PLC	Ver. 1.30 or later
FX3G Series PLC	Ver. 1.00 or later

FX3UC-4AD

Compatible PLC	Version number
FX3UC Series PLC	Ver. 1.30 or later

→ For a detailed description of version number check method, refer to Section 1.3.

8.2 Wiring Check

Check the wiring as follows:

1. Power

The 4AD needs driving power. Verify that the power supply line is properly connected. Also check that the 24 V indicator lamp of the 4AD is on.

2. Analog input line

Use the 2-core twisted shielded cable for the analog input line. In addition, be sure to separate the analog input line from any other power lines or inductive lines.

3. Use of current input mode

To use the current input mode for a channel, be sure to short-circuit the line between the V+ terminal and the I+ terminal of the channel.

Without short circuiting the terminals, it is impossible to obtain the correctly converted digital values.

→ For a detailed description of wiring, refer to Chapter 4.

8.3 Program Check

Check the program as follows:

1. Storage devices

Check whether the device holding digital values contains any values written by other programs.

2. Setting of averaging time and digital filter function

Check if the averaging time or the digital filter function is set for the same channel. It is not possible to set both functions for the same channel.

8.4 Error Status Check

If an error occurs in the 4AD, the corresponding bit of BFM #29 (error status buffer memory) will turn on. To solve the problem, refer to the troubleshooting method described below:

Bit No.	Items	Bit No.	Items
b0	Error detection	b8	Data setting error detection
b1	-	b9	-
b2	Power supply error	b10	Averaging time setting error
b3	Hardware error	b11	Digital filter setting error
b4	A/D conversion error	b12	Abrupt change detection value setting error
b5	-	b13	Upper/lower limit detection setting error
b6	BFM reading/writing impossible	b14	-
b7	-	b15	Addition data setting error

1. Error detection (b0)

- 1) Description of error
If any bits from b2 to b4 are turned on, this bit (b0) will turn on.

2. Power supply error (b2)

- 1) Description of error
The 24 V power is not being supplied properly.
- 2) Remedy
Check the wiring condition or the supplied voltage.

3. Hardware error (b3)

- 1) Description of error
4AD may be defective.
- 2) Remedy
Please contact the nearest Mitsubishi Electric distributor office.

4. A/D conversion error (b4)

- 1) Description of error
The A/D conversion value is abnormal.
- 2) Remedy
Check the over-scale status data (BFM #28) to localize the error channel. After that, check to make sure the input analog data is in the specified range.

5. BFM reading/writing impossible (b6)

- 1) Description of error
While voltage input characteristics are being changed, this bit will turn on. If this bit (b6) is on, A/D conversion data cannot be read out correctly or cannot be written to the BFM correctly.
- 2) Remedy
Check the sequence program and confirm that the input characteristics (BFM #21 b0 to b3) are not being written continuously.

6. Data setting error detection (b8)

- 1) Description of error
If any bits from b10 to b15 are turned on, this bit (b8) will turn on.

7. Averaging time setting error (b10)

- 1) Description of error
The averaging time (BFM #2 to #5) is not set correctly.
- 2) Remedy
Set the averaging time again in the range from 1 to 4095.

8. Digital filter setting error (b11)

- 1) Description of error
The digital filter value (BFM #6 to #9) is not set correctly.
- 2) Remedy
Set the digital filter value again in the range from 0 to 1600.
Also check that the averaging is not set for the selected channel.

9. Abrupt change detection value setting error (b12)

- 1) Description of error
The abrupt change detection value (BFM #91 to #94) is not set correctly.
- 2) Remedy
Check that the abrupt change detection value is in the range specified for the selected input mode. If the value is out of the range, correct it.

10. Upper/lower limit detection setting error (b13)

- 1) Description of error
The lower limit error detection value (BFM #71 to #74) or the upper limit error detection value (BFM #81 to #84) is not set correctly.
- 2) Remedy
Check that the upper/lower limit error detection value is in the range specified for the selected input mode. If the value is out of the range, correct it.

11. Addition data setting error (b15)

- 1) Description of error
The addition data (BFM #61 to #64) is not set correctly.
- 2) Remedy
Set the addition data again in the range from -16000 to +16000.

8.5 4AD Initialization and Test Program

If the remedies above cannot solve the problem, initialize and then check the conditions of the 4AD using the test program.

- For a detailed description of 4AD initialization program, refer to Subsection 7.4.
- For a detailed description of the test program, refer to Chapter 4.

FX3G/FX3U/FX3UC Series Programmable Controllers

User's Manual [Analog Control Edition] FX3U-4AD-ADP (4-channel analog Input)

Foreword

This manual describes the specifications, wiring, and operation methods for the FX3U-4AD-ADP special adapter (4-channel analog input) and should be read and understood before attempting to install or use the unit.

Store this manual in a safe place so that you can take it out and read it whenever necessary. Always forward it to the end user.

This manual confers no industrial property rights or any rights of any other kind, nor does it confer any patent licenses. Mitsubishi Electric Corporation cannot be held responsible for any problems involving industrial property rights which may occur as a result of using the contents noted in this manual.

© 2005 MITSUBISHI ELECTRIC CORPORATION

A
Common Items

B
FX3U-4AD
FX3UC-4AD

C
FX3U-4AD-ADP

D
FX3G-2AD-BD

E
FX3U-4DA

F
FX3U-4DA-ADP

G
FX3G-1DA-BD

H
FX3U-3A-ADP

I
FX3U-4AD-PT
-ADP

J
FX3U-4AD-PTW
-ADP

1. Outline

This chapter outlines the FX3U-4AD-ADP (referred to as the 4AD-ADP).

1.1 Outline of Functions

The FX3U-4AD-ADP is an analog special adapter. Connect the FX3U-4AD-ADP to the FX3U/FX3UC/FX3G Series PLC to read 4 channels of voltage/current data.

- 1) Up to 4 4AD-ADP units can be connected to the FX3U/FX3UC Series PLC.
 Up to 2*1 4AD-ADP units can be connected to the FX3G Series PLC.
 (including the other analog special adapters).
- 2) Either "voltage input" or "current input" can be specified for each channel.
- 3) A/D conversion data of each channel will be automatically written to the special data register of the FX3U/FX3UC/FX3G Series PLC.

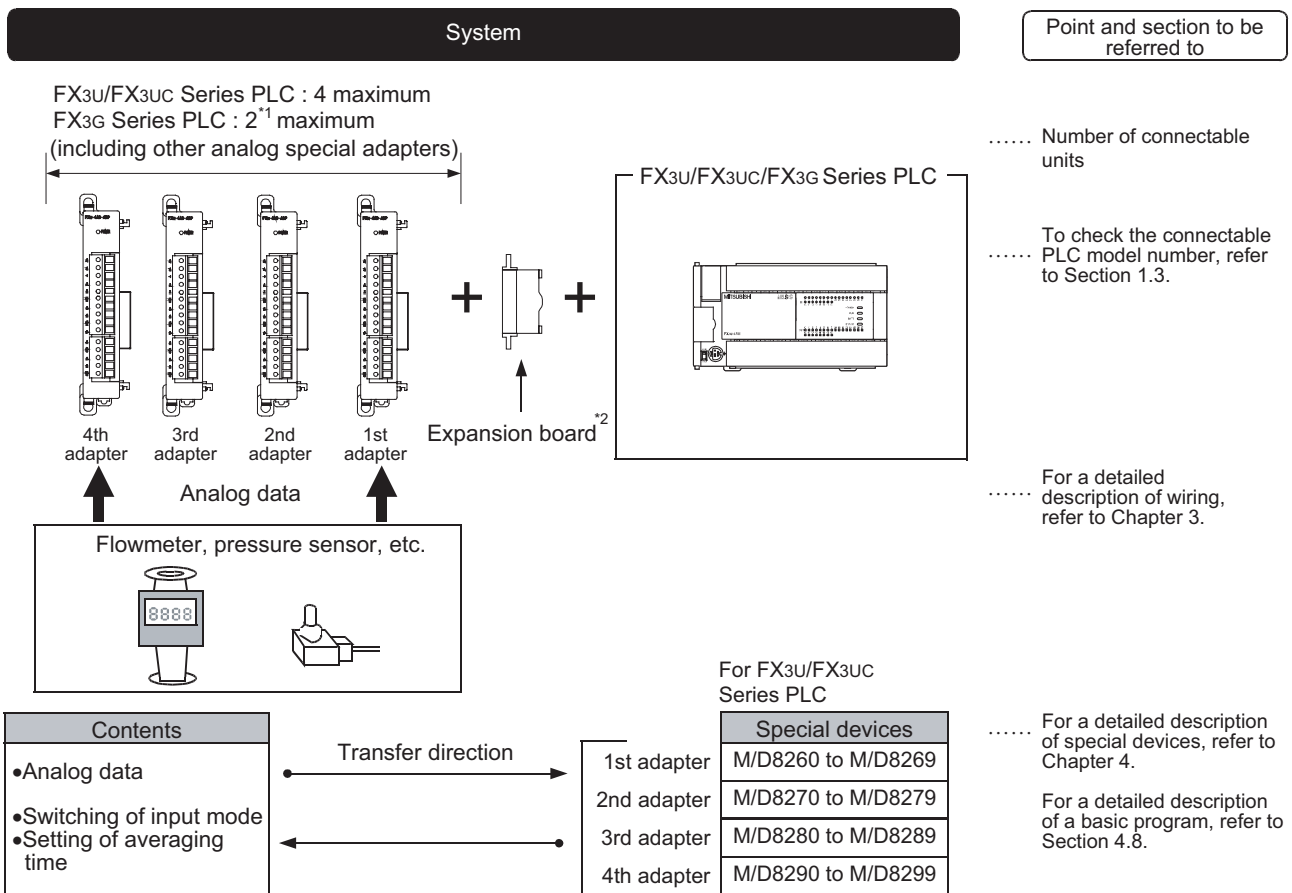

Refer to the system configuration shown in the User's Manual - Hardware Edition to check the number of connectable units and to configure the entire system.

*1. Only 1 analog special adapter can be connected to the 14-point and 24-point type main unit.

*2. The expansion board is not required when connecting with the FX3UC (D, DSS) PLC.
 For the FX3G Series PLC a connector conversion adapter is used.

1.2 Setup Procedure Before Starting Operation

Before starting analog input using the 4AD-ADP, follow the procedure below to set up the system:

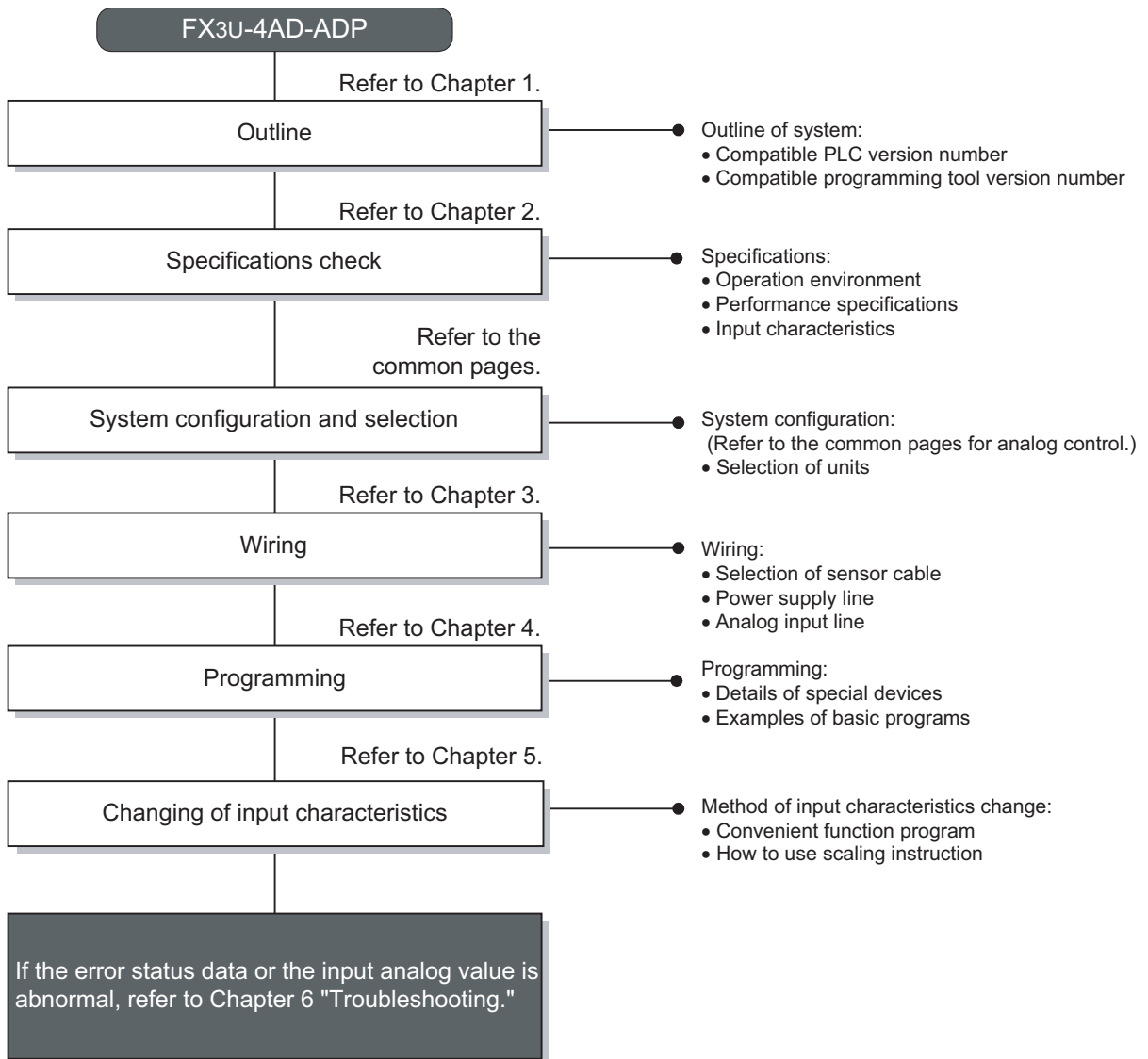

1.3 Connectable PLCs and Version Number

The 4AD-ADP is compatible with the following PLCs.

Compatible PLC	Version number	Date of production
FX3U Series PLC	Ver.2.20 or later*1	After May 2005 (initial production)
FX3UC Series PLC	Ver.1.20 or later*1	After April 2004
FX3G Series PLC	Ver.1.00 or later	After June 2008 (initial production)

*1. The FX3U/FX3UC Series PLC Ver. 2.70 or later supports the under-scale detection.

1. Version check

Special data register D8001 contains information for determining the PLC version number.

→ For a detailed description of the version check, refer to A. Common Items Subsection 5.1.2.

2. How to check the manufacturer's serial number

The year and month of production of the product can be checked on the nameplate, and on the front of the product.

→ For a detailed description of how to check the manufacturer's serial number, refer to A. Common Items Subsection 5.1.1.

1.4 Compatible Programming Tool Version Number

Use the programming tool with following version numbers to create programs for the 4AD-ADP:

1. GX Works2

Software	Version number	Remarks
GX Works2 SW□DNC-GXW2-J	Ver. 1.07H or later	-
GX Works2 SW□DNC-GXW2-E	Ver. 1.08J or later	-

2. GX Developer

- FX3U/FX3UC Series PLC

Software	Version number	Remarks
GX Developer SW□D5C-GPPW-J	Ver. 8.13P or later	When selecting the model, select FX3U(C)*2.
GX Developer SW□D5C-GPPW-E	Ver. 8.18U or later	

- FX3G Series PLC

Software	Version number	Remarks
GX Developer • SW□D5C-GPPW-J • SW□D5C-GPPW-E	Ver. 8.72A or later	-

If a programming tool with the wrong version number is used, programming will not be possible.

*2. For Ver. 8.13P to 8.24A of GX Developer, select FX3UC for the PLC type.

3. FX-30P

Model name	Version number	Remarks
FX-30P	Ver.1.00 or later	-

2. Specifications

This chapter describes the general, power supply, and performance specifications for the 4AD-ADP.

2.1 Generic Specifications

Item	Specifications				
Ambient temperature	0 to 55°C (32 to 131°F) when operating -25 to 75°C (-13 to 167°F) when stored				
Relative humidity	5 to 95%RH (no condensation) when operating				
Vibration resistance *1	DIN Rail Mounting	Frequency (Hz)	Acceleration (m/s ²)	Half amplitude (mm)	Tests 10 times in each direction (X-, Y-, and Z-axis directions) (Total: 80 min, each)
		10 - 57	-	0.035	
	Direct Mounting *2	57 - 150	4.9	-	
		10 to 57	-	0.075	
		57 to 150	9.8	-	
Shock resistance *1	147 m/s ² Acceleration, Action time: 11ms, 3 times by half-sine pulse in each direction X, Y, and Z				
Noise resistance	Using noise simulator of: Noise voltage: 1,000Vp-p / Noise width: 1μs / Rise: 1ns / Cycle: 30 to 100Hz				
Dielectric withstand voltage	500 V AC, for 1 min	Between all terminals and ground terminal			
Insulation resistance	5MΩ or more using 500V DC insulation resistance meter				
Grounding	Class D grounding (grounding resistance: 100 Ω or less) <Common grounding with a heavy electrical system is not allowed.>*3				
Working environment	Free from corrosive or flammable gas and excessive conductive dusts				
Working altitude	< 2000m*4				

*1. The criterion is shown in IEC61131-2.

*2. If 4AD-ADP is connected to the FX3uc Series PLC, direct installation is not possible.

*3.

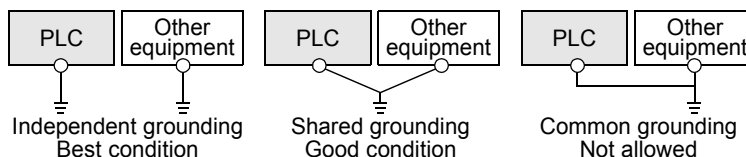

→ For a detailed description of the grounding, refer to Section 3.5.

*4. If the pressure is higher than the atmospheric pressure, do not use the 4AD-ADP.
 The 4AD-ADP may malfunction.

2.2 Power Supply Specifications

Item	Specifications
A/D conversion circuit driving power	24V DC +20%-15%, 40mA (It is necessary to connect a 24V DC power supply to the terminal block.)
Interface driving power	5V DC, 15mA (Since the internal power is supplied from the FX Series main unit, it is not necessary to supply the power.)

2.3 Performance Specifications

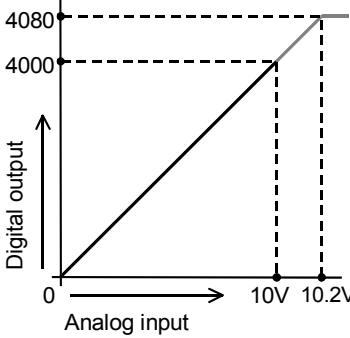
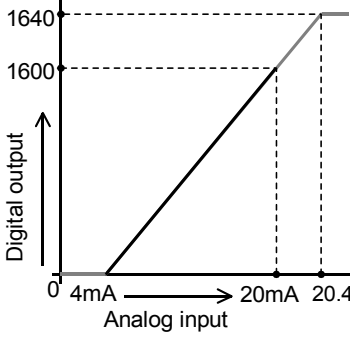
Item	Specifications	
	Voltage input	Current input
Analog input range	0V to 10V DC (Input resistance: 194 kΩ)	4mA to 20mA DC (Input resistance: 250 Ω)
Absolute input maximum	-0.5V, +15V	-2mA, +30mA
Digital output	12 bits, binary	11 bits, binary
Resolution	2.5mV (10V/4000)	10μA (16mA/1600)
Total accuracy	<ul style="list-style-type: none"> ±0.5% (±50mV) for 10V full scale (when ambient temperature is 25°C ± 5°C) ±1.0% (±100mV) for 10V full scale (when ambient temperature is 0°C to 55°C) 	<ul style="list-style-type: none"> ±0.5% (±80μA) for 16mA full scale (when ambient temperature is 25°C ± 5°C) ±1.0% (±160μA) for 16mA full scale (when ambient temperature is 0°C to 55°C)
A/D conversion time	<ul style="list-style-type: none"> FX3U/ FX3UC Series PLC : 200 μs (The data will be updated at every scan time.) FX3G Series PLC : 250 μs (The data will be updated at every scan time.) → For a detailed description of data update, refer to Section 2.4.	
Input characteristics		
Insulation method	<ul style="list-style-type: none"> The photocoupler is used to insulate the analog input area from the PLC. The DC/DC converter is used to insulate the power supply line from the analog input area. Channels are not insulated from each other. 	
Number of I/O points occupied	0 point (This number is not related to the maximum number of input/output points of the PLC.)	

A Common Items
 B FX3U-4AD FX3UC-4AD
 C FX3U-4AD-ADP
 D FX3G-2AD-BD
 E FX3U-4DA
 F FX3U-4DA-ADP
 G FX3G-1DA-BD
 H FX3U-3A-ADP
 I FX3U-4AD-PT-ADP
 J FX3U-4AD-PTW-ADP

2.4 A/D Conversion Time

This section describes the A/D conversion time.

2.4.1 When connected to a FX3U, FX3UC PLC

1. A/D conversion and special data register update timing

A/D conversion is performed at every scan time of the PLC.

During execution of END instruction, the PLC performs A/D conversion, reads out the A/D converted data, and then writes the data in the special data registers.

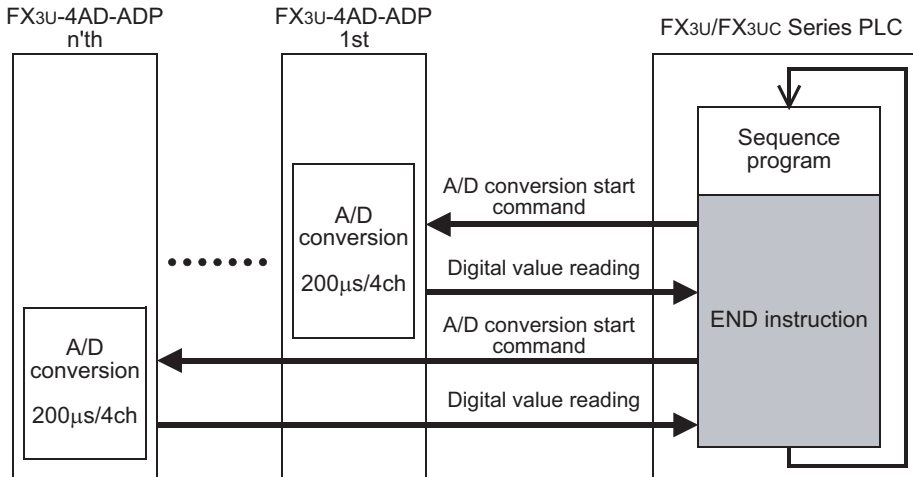

2. A/D conversion during PLC STOP

Even if the PLC is stopped, A/D conversion will be performed and the special data registers will be updated.

3. If two or more analog special adapters are connected

During execution of the END instruction, data will be read out from all the connected adapters (in the order of 1st adapter → 2nd adapter... 4th adapter).

4. A/D conversion speed (data update time)

During execution of END instruction, the A/D converted data of all 4 channels will be read out in 200μs, and the data read out will be written to the special data registers.

END instruction execution time will be "200μs × number of connected analog adapters."

2.4.2 When connected to a FX3G PLC

1. A/D conversion and special data register update timing

A/D conversion is performed at every scan time of the PLC.

During execution of END instruction, the PLC performs A/D conversion, reads out the A/D converted data, and then writes the data in the special data registers.

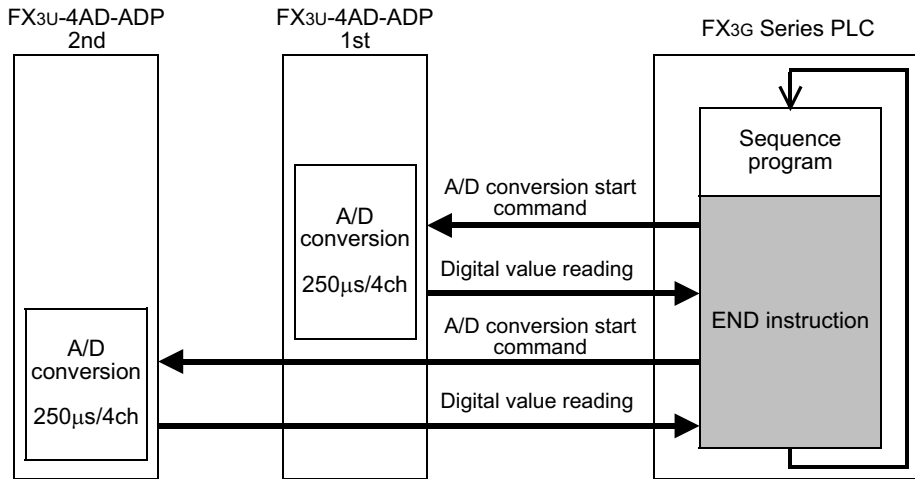

2. A/D conversion during PLC STOP

Even if the PLC is stopped, A/D conversion will be performed and the special data registers will be updated.

3. If two analog special adapters are connected

During execution of the END instruction, data will be read out from all the connected adapters (in the order of 1st adapter → 2nd adapter).

4. A/D conversion speed (data update time)

During execution of END instruction, the A/D converted data of all 4 channels will be read out in 250µs, and the data read out will be written to the special data registers.

END instruction execution time will be "250µs × number of connected analog adapters."

A	Common Items
B	FX3U-4AD FX3UC-4AD
C	FX3U-4AD-ADP
D	FX3G-2AD-BD
E	FX3U-4DA
F	FX3U-4DA-ADP
G	FX3G-1DA-BD
H	FX3U-3A-ADP
I	FX3U-4AD-PT -ADP
J	FX3U-4AD-PTW -ADP

3. Wiring

This chapter describes the 4AD-ADP wiring.
Observe the following caution to wire the 4AD-ADP.

WIRING PRECAUTIONS



DANGER

- Make sure to cut off all phases of the power supply externally before attempting wiring work. Failure to do so may cause electric shock or damages to the product.

WIRING PRECAUTIONS



CAUTION

- Connect the DC power supply wiring to the dedicated terminals described in this manual. If an AC power supply is connected to a DC input/output terminal or DC power supply terminal, the PLC will be burnt out.
- Do not wire vacant terminals externally. Doing so may damage the product.
- Perform class D grounding (grounding resistance: 100Ω or less) to the grounding terminal on the main unit. Do not use common grounding with heavy electrical systems.
- When drilling screw holes or wiring, make sure cutting or wire debris does not enter the ventilation slits. Failure to do so may cause fire, equipment failures or malfunctions.
- Make sure to observe the following precautions in order to prevent malfunctions under the influence of noise:
 - Do not bundle the power line or twisted shielded cable together with or lay it close to the main circuit, high-voltage line, or load line. Otherwise, noise disturbance and/or surge induction are likely to take place. As a guideline, lay the control line at least 100mm (3.94") or more away from the main circuit, high-voltage line, or load line.
 - Ground the shield of the analog input/output cable at one point on the signal receiving side. However, do not use common grounding with heavy electrical systems.
- Make sure to properly wire to the European terminal board in accordance with the following precautions. Failure to do so may cause electric shock, equipment failures, a short-circuit, wire breakage, malfunctions, or damage to the product.
 - The disposal size of the cable end should follow the dimensions described in the manual.
 - Tightening torque should follow the specifications in the manual.
 - Twist the end of strand wire and make sure there are no loose wires.
 - Do not solder-plate the electric wire ends.
 - Do not connect more than the specified number of wires or electric wires of unspecified size.
 - Affix the electric wires so that neither the terminal block nor the connected parts are directly stressed.

3.1 Terminal Layout

The terminals of the 4AD-ADP are arranged as follows:

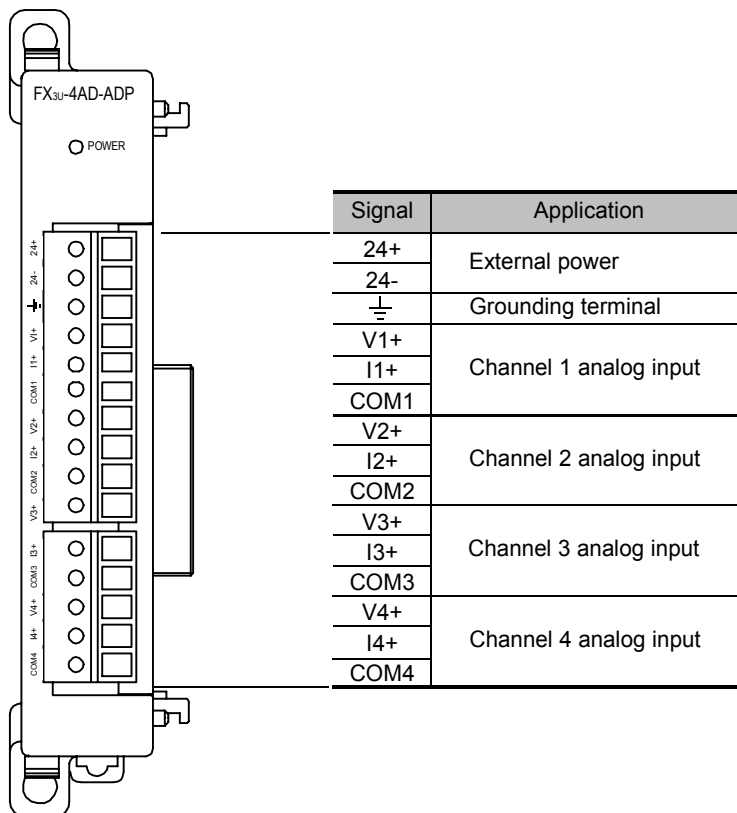

A

Common Items

B

FX3U-4AD
FX3UC-4AD

C

FX3U-4AD-ADP

D

FX3G-2AD-BD

E

FX3U-4DA

F

FX3U-4DA-ADP

G

FX3G-1DA-BD

H

FX3U-3A-ADP

I

FX3U-4AD-PT-ADP

J

FX3U-4AD-PTW-ADP

3.2 Applicable Cables and Terminal Tightening Torque

Use the following cables to connect with the counterpart equipment. Terminate the cable ends as shown below.

1. Cables

Applicable cable and tightening torque

	Wire size (stranded/ single-wire)	Tightening torque	Termination
Single-wire	0.3mm ² to 0.5mm ² (AWG22 to 20)	0.22N•m to 0.25N•m	<ul style="list-style-type: none"> To connect a stranded cable, peel the cover off the cable and then twist the core before connection. To connect a single-wire cable, just strip the cover off the cable before connection.
2-wire	0.3mm ² (AWG22)		
Rod terminal with insulation sleeve	0.3mm ² to 0.5mm ² (AWG22 to 20) (Refer to the rod terminal external view shown in the following figure.)		<ul style="list-style-type: none"> Rod terminal with insulation sleeve (recommended terminal) AI 0.5-8WH : Manufactured by Phoenix Contact Caulking tool CRIMPFOX 6*1 : Manufactured by Phoenix Contact (or CRIMPFOX 6T-F*2 : Manufactured by Phoenix Contact)

*1. Old model name : CRIMPFOX ZA 3

*2. Old model name : CRIMPFOX UD 6

2. Termination of cable end

To terminate the cable, treat the stranded/single-wire directly or use a rod terminal with insulation sleeve.

- To directly terminate the end of a stranded/single-wire cable:
 - Twist the end of the stranded cable so that the "barbed wires" cannot protrude.
 - Do not solder-plate the end of the cable.

Termination of cable end

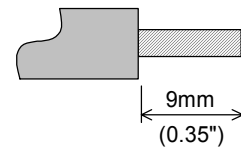

- To terminate cable end using a rod terminal with insulation sleeve:
 If the cable cover is too thick, it may be difficult to insert the cable into the insulation sleeve. For this reason, select an appropriate cable while referring to the external view.

<Reference>

Manufacturer	Model	Caulking tool
Phoenix Contact	AI 0.5-8WH	CRIMPFOX 6*3 (or CRIMPFOX 6T-F*4)

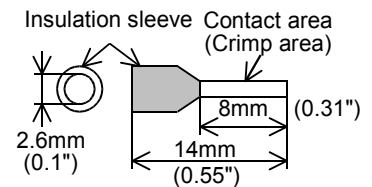

*3. Old model name : CRIMPFOX ZA 3

*4. Old model name : CRIMPFOX UD 6

3. Tool

- To tighten terminals, use a small-sized screwdriver whose head is straight and is not widened as shown in the figure to the right.

Note:

If the diameter of screwdriver grip is too small, tightening torque will not be able to be achieved. To achieve the appropriate tightening torque shown in the table above, use the following screwdriver or an appropriate replacement (grip diameter: approximately 25mm (0.98")).

<Reference>

Manufacturer	Model
Phoenix Contact	SZS 0.4×2.5

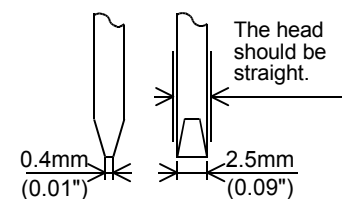

3.3 Power Supply Line

Connect the 24V DC power supply line of the 4AD-ADP to the 24+ and 24- terminals of the terminal block.

3.3.1 To connect to the FX3G, FX3U Series PLC

1. To use an External power supply

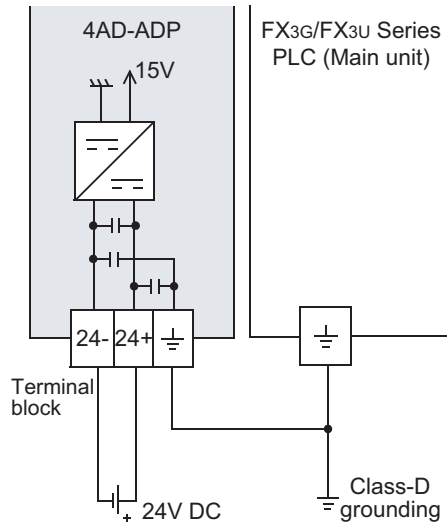

2. To use the 24V DC power of the PLC

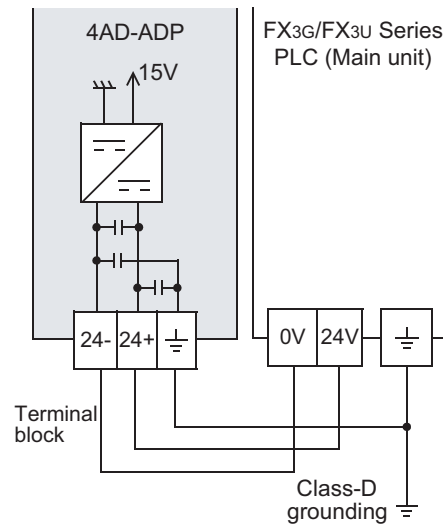

Caution regarding connection of the power supply line:

- Ground the " \perp " terminal to a class-D grounded power supply line (100Ω or less) together with the grounding terminal of the PLC main unit.
- When using an external power supply, turn it ON at the same time with the main unit or earlier than the main unit. When turning OFF the power, confirm the safety of the system, and then turn OFF the power of the PLC (including special adapter) at the same time.

3.3.2 To connect to the FX3UC Series PLC

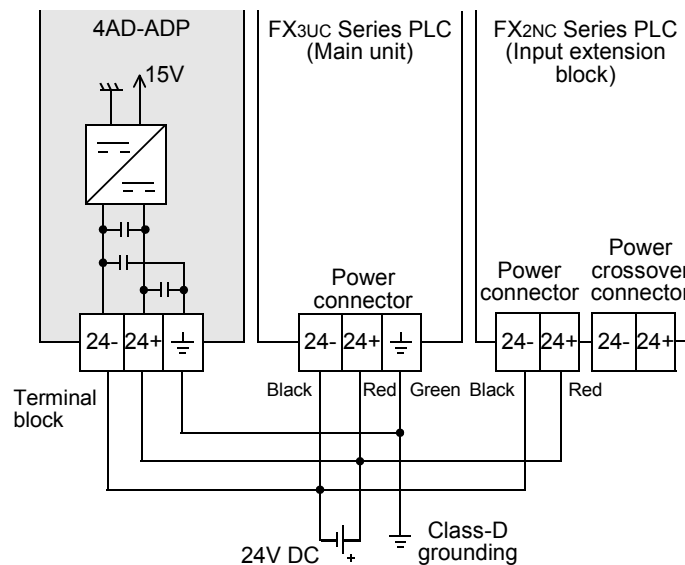

Cautions regarding connection of the power supply line:

- For the 24V DC power supply line, be sure to use the same power as the FX3UC Series PLC.
- Ground the " \perp " terminal to a class-D grounded power supply line (100Ω or less) together with the grounding terminal of the PLC main unit.

3.4 Analog Input Line

For analog input, "voltage input" or "current input" can be selected for each channel.

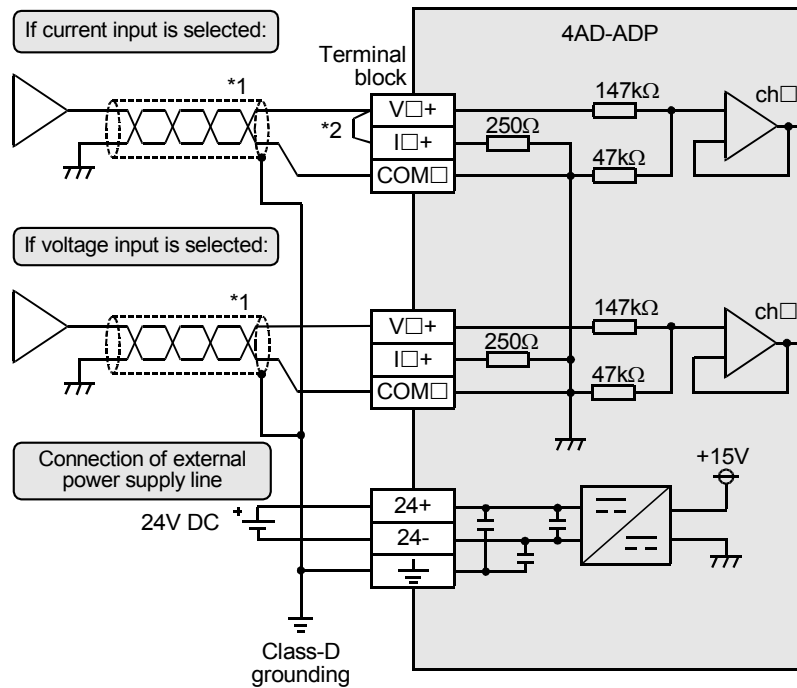

V□+, I□+, ch□ : □ represents the channel number.

- *1. Use the 2-core shielded twisted pair cable for the analog input lines, and separate the analog input lines from other power lines or inductive lines.
- *2. If "current input" is selected, be sure to short the line between the V□+ terminal and the I□+ terminal. (□: Channel number).

3.5 Grounding

Grounding should be performed as stated below.

- The grounding resistance should be 100Ω or less.
- Independent grounding should be performed for best results. When independent grounding is not performed, perform "shared grounding" as shown in the following figure.

→ For details, refer to the User's Manual - Hardware Edition of the PLC Series.

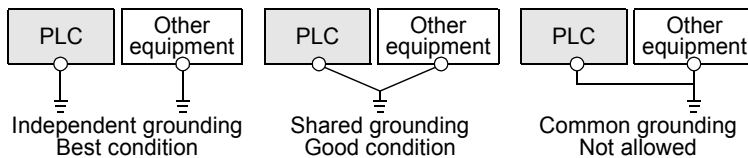

- The grounding wire size should be AWG22 to 20 (0.3 to 0.5 mm²).
- The grounding point should be close to the PLC, and all grounding wires should be as short as possible.

4. Programming

This chapter describes how to create programs that can read analog data using the 4AD-ADP.

4.1 Loading of A/D Conversion Data

- 1) The input analog data will be converted into digital data and then stored in the special devices of the FX3U/FX3UC/FX3G Series PLC.
- 2) If the data is stored in the special devices, the averaging time can be set, and the input mode can be specified.
- 3) Special auxiliary relays (10 points) and special data registers (10 points) are assigned automatically starting from the adapter nearest to the main unit.

→ For a detailed description of special device assignment, refer to Section 4.2.

- FX3U, FX3UC Series PLC

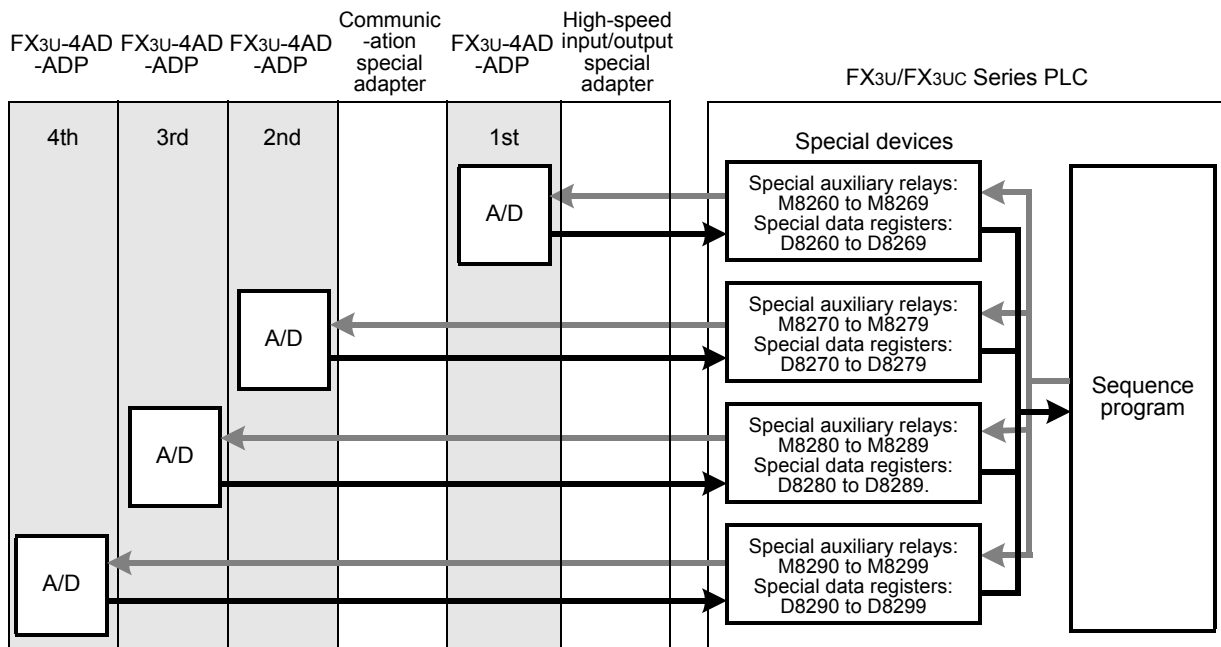

The analog special adapter nearest to the main unit is counted as the 1st analog special adapter, and the next adapter as the 2nd analog special adapter, and so on. However, in this case, do not include the high-speed input/output special adapter, communication special adapter, and the CF card special adapter.

• FX3G Series PLC

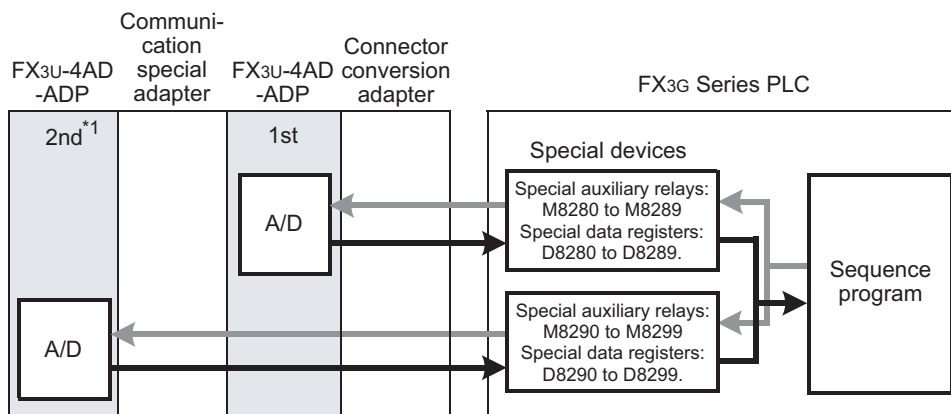

The analog special adapter nearest to the main unit is counted as the 1st analog special adapter, and the next adapter as the 2nd analog special adapter. However, in this case, do not include the connector conversion adapter and the communication special adapter.

*1. The second special adapter is not available in the FX3G Series PLC(14-point and 24-point type).

4.2 List of Special Devices

If the 4AD-ADP is connected, special devices will be assigned automatically as shown in the following table:

- FX3U, FX3UC Series PLC

R: Read / W: Write

Special device	Device number				Description	Attribute	Reference
	1st	2nd	3rd	4th			
Special auxiliary relay	M8260	M8270	M8280	M8290	Switches the input mode of channel 1	R/W	Section 4.3
	M8261	M8271	M8281	M8291	Switches the input mode of channel 2	R/W	
	M8262	M8272	M8282	M8292	Switches the input mode of channel 3	R/W	
	M8263	M8273	M8283	M8293	Switches the input mode of channel 4	R/W	
	M8264 to M8269	M8274 to M8279	M8284 to M8289	M8294 to M8299	Unused (Do not use.)	-	-
Special data register	D8260	D8270	D8280	D8290	Channel-1 input data	R	Section 4.4
	D8261	D8271	D8281	D8291	Channel-2 input data	R	
	D8262	D8272	D8282	D8292	Channel-3 input data	R	
	D8263	D8273	D8283	D8293	Channel-4 input data	R	
	D8264	D8274	D8284	D8294	Averaging time for channel-1 (Setting range: 1 to 4095)	R/W	Section 4.5
	D8265	D8275	D8285	D8295	Averaging time for channel-2 (Setting range: 1 to 4095)	R/W	
	D8266	D8276	D8286	D8296	Averaging time for channel-3 (Setting range: 1 to 4095)	R/W	
	D8267	D8277	D8287	D8297	Averaging time for channel-4 (Setting range: 1 to 4095)	R/W	
	D8268	D8278	D8288	D8298	Error status	R/W	Section 4.6
D8269	D8279	D8289	D8299	Model code = 1	R	Section 4.7	

A
Common Items

B
FX3U-4AD
FX3UC-4AD

C
FX3U-4AD-ADP

D
FX3G-2AD-BD

E
FX3U-4DA

F
FX3U-4DA-ADP

G
FX3G-1DA-BD

H
FX3U-3A-ADP

I
FX3U-4AD-PT-ADP

J
FX3U-4AD-PTW-ADP

- FX3G Series PLC

R: Read / W: Write

Special device	Device number		Description	Attribute	Reference
	1st	2nd			
Special auxiliary relay	M8280	M8290	Switches the input mode of channel 1	R/W	Section 4.3
	M8281	M8291	Switches the input mode of channel 2	R/W	
	M8282	M8292	Switches the input mode of channel 3	R/W	
	M8283	M8293	Switches the input mode of channel 4	R/W	
	M8284 to M8289	M8294 to M8299	Unused (Do not use.)	-	-
Special data register	D8280	D8290	Channel-1 input data	R	Section 4.4
	D8281	D8291	Channel-2 input data	R	
	D8282	D8292	Channel-3 input data	R	
	D8283	D8293	Channel-4 input data	R	
	D8284	D8294	Averaging time for channel-1 (Setting range: 1 to 4095)	R/W	Section 4.5
	D8285	D8295	Averaging time for channel-2 (Setting range: 1 to 4095)	R/W	
	D8286	D8296	Averaging time for channel-3 (Setting range: 1 to 4095)	R/W	
	D8287	D8297	Averaging time for channel-4 (Setting range: 1 to 4095)	R/W	
	D8288	D8298	Error status	R/W	Section 4.6
	D8289	D8299	Model code = 1	R	Section 4.7

4.3 Switching of Input Mode

Turn the special auxiliary relay on/off to switch the input mode of 4AD-ADP between the current input mode and the voltage input mode.

To switch the input mode, use the following special auxiliary relays:

- FX3U, FX3UC Series PLC

Special auxiliary relay				Description
1st	2nd	3rd	4th	
M8260	M8270	M8280	M8290	Switches the input mode of channel 1
M8261	M8271	M8281	M8291	Switches the input mode of channel 2
M8262	M8272	M8282	M8292	Switches the input mode of channel 3
M8263	M8273	M8283	M8293	Switches the input mode of channel 4

OFF: Voltage input
 ON: Current input

- FX3G Series PLC

Special auxiliary relay		Description
1st	2nd	
M8280	M8290	Switches the input mode of channel 1
M8281	M8291	Switches the input mode of channel 2
M8282	M8292	Switches the input mode of channel 3
M8283	M8293	Switches the input mode of channel 4

OFF: Voltage input
 ON: Current input

1. Program Example (For FX3U, FX3UC Series PLC)

To switch the channel input mode, create a sequence program as follows:

- 1) To switch the input mode of channel 1 of the 1st analog special adapter to the voltage input mode:

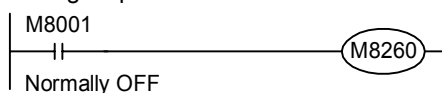

- 2) To switch the input mode of channel 2 of the 1st analog special adapter to the current input mode:

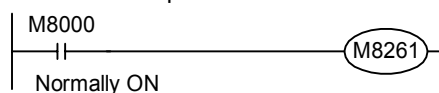

4.4 Input Data

Numeric data type: Decimal (K)

The data converted by the 4AD-ADP will be stored in the special data registers.
 The special data registers that store the input data are shown in the following table:

- FX3U, FX3UC Series PLC

Special data register				Description
1st	2nd	3rd	4th	
D8260	D8270	D8280	D8290	Stores the channel-1 input data
D8261	D8271	D8281	D8291	Stores the channel-2 input data
D8262	D8272	D8282	D8292	Stores the channel-3 input data
D8263	D8273	D8283	D8293	Stores the channel-4 input data

- FX3G Series PLC

Special data register		Description
1st	2nd	
D8280	D8290	Stores the channel-1 input data
D8281	D8291	Stores the channel-2 input data
D8282	D8292	Stores the channel-3 input data
D8283	D8293	Stores the channel-4 input data

The converted A/D immediate data or averaged data (data average conforming to the specified averaging time) will be stored in the above data registers as the input data.

→ For a detailed description of the averaging time, refer to Section 4.5.

1. Caution regarding input data

Input data is for reading only.

Do not change (rewrite) the input data using sequence program, indicator, or device monitor of the programming tool.

2. Program Example (For FX3U, FX3UC Series PLC)

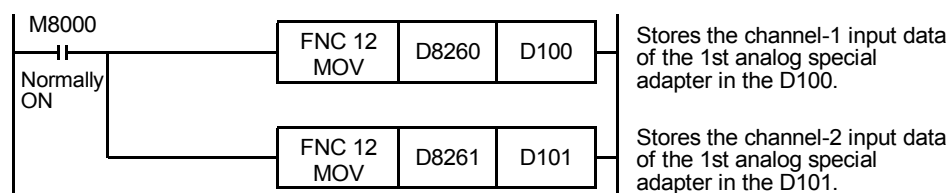

Stores the channel-1 input data of the 1st analog special adapter in the D100.

Stores the channel-2 input data of the 1st analog special adapter in the D101.

Even if the input data is not stored in D100 or D101, data registers D8260 or D8261 can be directly used in the timer/counter set value or in a PID instruction.

4.5 Averaging Time

Setting range: 1 to 4095

Initial value: K1

Numeric data type: Decimal (K)

If the averaging time is set for the 4AD-ADP, the average data will be stored as the input data. The averaging time can be set for each channel.

Set the averaging time in the following special data registers:

- FX3U, FX3UC Series PLC

Special data register				Description
1st	2nd	3rd	4th	
D8264	D8274	D8284	D8294	Averaging time for channel-1 data
D8265	D8275	D8285	D8295	Averaging time for channel-2 data
D8266	D8276	D8286	D8296	Averaging time for channel-3 data
D8267	D8277	D8287	D8297	Averaging time for channel-4 data

- FX3G Series PLC

Special data register		Description
1st	2nd	
D8284	D8294	Averaging time for channel-1 data
D8285	D8295	Averaging time for channel-2 data
D8286	D8296	Averaging time for channel-3 data
D8287	D8297	Averaging time for channel-4 data

1. Cautions regarding averaging time setting

- If the averaging time is set to "1", the immediate data is stored to the special data register.
- If the averaging time is set in the range from 2 to 4095, the average value will be calculated to conform to the set averaging time, and the average value obtained will be stored in the special data register.
- After turning the PLC power on, the current data is stored to special data registers until the number of data items reaches the set averaging time. After this, the average data will be stored.
- Set the averaging time in the range from 1 to 4095. If the set value is outside the setting range, an error signal will be output.
- If the averaging time is set to "0" or smaller, the PLC will perform as if the averaging time is set to "1".
 If the averaging time is set to "4096" or larger, the PLC will perform as if the averaging time is set to "4096".
 → For a detailed description of the error status, refer to Section 6.5

2. Program Example (For FX3U, FX3UC Series PLC)

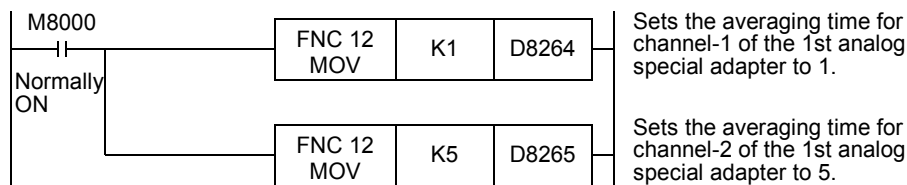

4.6 Error Status

If an error is detected in the 4AD-ADP, the error status data will be stored in the corresponding special data register.

The following table shows the special data registers that store the error status data:

- FX3U, FX3UC Series PLC

Special data register				Description
1st	2nd	3rd	4th	
D8268	D8278	D8288	D8298	Stores the error status data.

- FX3G Series PLC

Special data register		Description
1st	2nd	
D8288	D8298	Stores the error status data.

Check the ON/OFF status of each bit of the error status data register to check the description of the error. Errors are assigned to the bits as shown in the following table. Create a program to detect errors.

→ For a detailed description of the error status, refer to Section 6.5.

Bit	Description	Bit	Description
b0	Channel-1 over-scale detection	b7	4AD-ADP communication data error
b1	Channel-2 over-scale detection	b8	Channel-1 under-scale detection*1
b2	Channel-3 over-scale detection	b9	Channel-2 under-scale detection*1
b3	Channel-4 over-scale detection	b10	Channel-3 under-scale detection*1
b4	EEPROM error	b11	Channel-4 under-scale detection*1
b5	Averaging time setting error	b12 to b15	Unused
b6	4AD-ADP hardware error (Power supply error included)	-	-

- *1. The FX3U/FX3UC Series PLC Ver.2.70 or later supports the under-scale detection function. The under-scale detection function is valid only for current input mode.

1. Caution regarding use of error status data

If a 4AD-ADP hardware error (b6) or 4AD-ADP communication data error (b7) is detected, it is necessary to clear the error status with a program at the next power-on of the PLC.

For this reason, be sure to create the following program:

- For FX3G, FX3U, FX3UC Series PLC

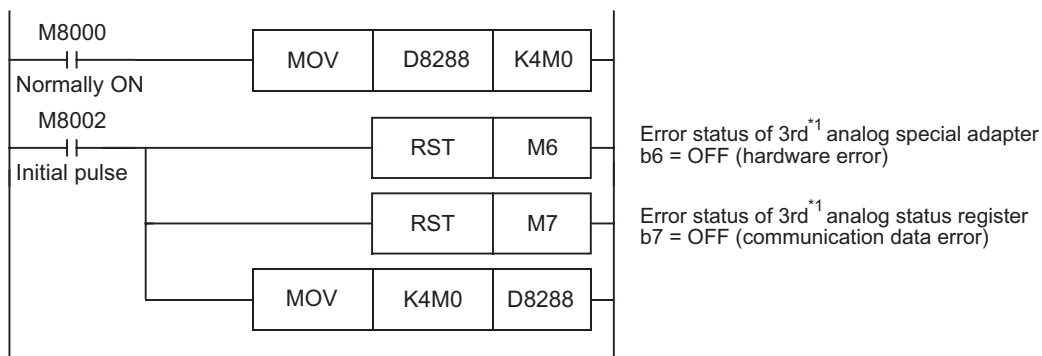

- *1. "1st" for the FX3G PLC.

- For FX3U, FX3UC Series PLC

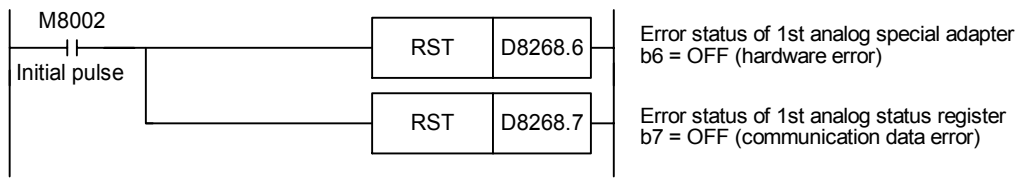

2. Program Example 1 (For FX3G, FX3U, FX3UC Series PLC)

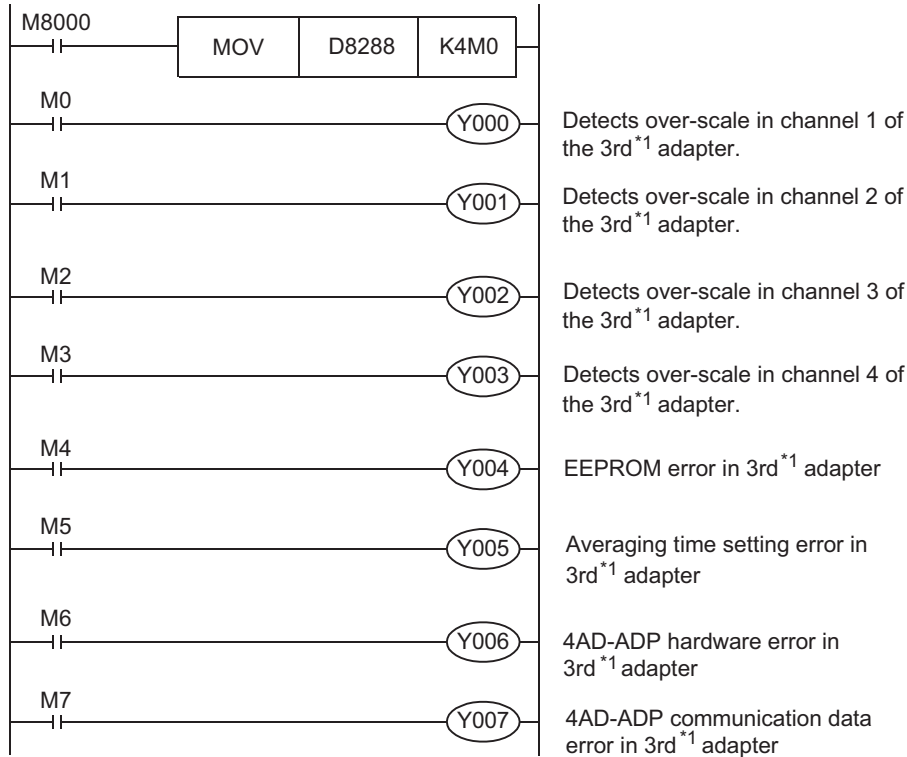

*1. "1st" for the FX3G PLC.

3. Program Example 2 (For FX3U, FX3UC Series PLC)

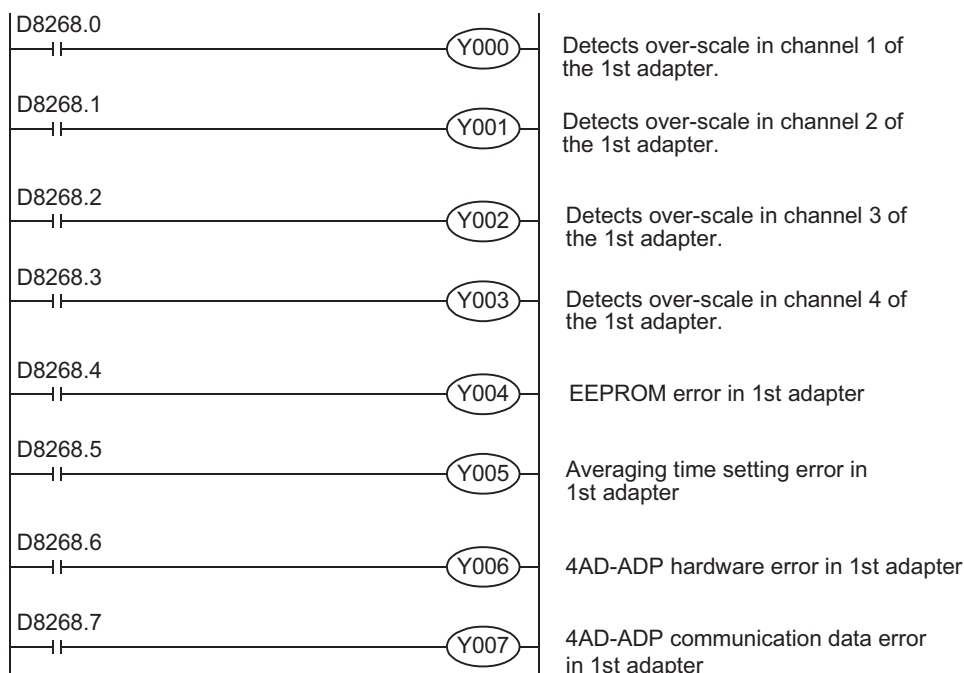

4.7 Model Code

Initial value: K1
Numeric data type: Decimal (K)

When the 4AD-ADP is connected, model code "1" is stored in the corresponding special data register.
 The following table shows the special data registers that store the model code:

- FX3U, FX3UC Series PLC

Special data register				Description
1st	2nd	3rd	4th	
D8269	D8279	D8289	D8299	Model code

- FX3G Series PLC

Special data register		Description
1st	2nd	
D8289	D8299	Model code

Use the special data registers above to check whether a 4AD-ADP is connected or not.

1. Program Example (For FX3U, FX3UC Series PLC)

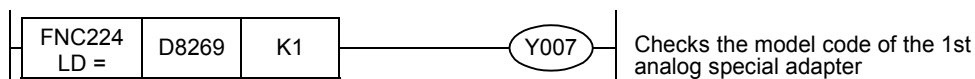

4.8 Basic Program Example

Create the following basic program example to read out analog conversion (A/D conversion) data.

- For FX3G, FX3U, FX3UC Series PLC

The following program will set channel 1 of the 3rd^{*1} adapter to voltage input mode and channel 2 to current input mode, and will store the converted A/D value of channel-1 data into D100 and that of channel-2 data into D101.

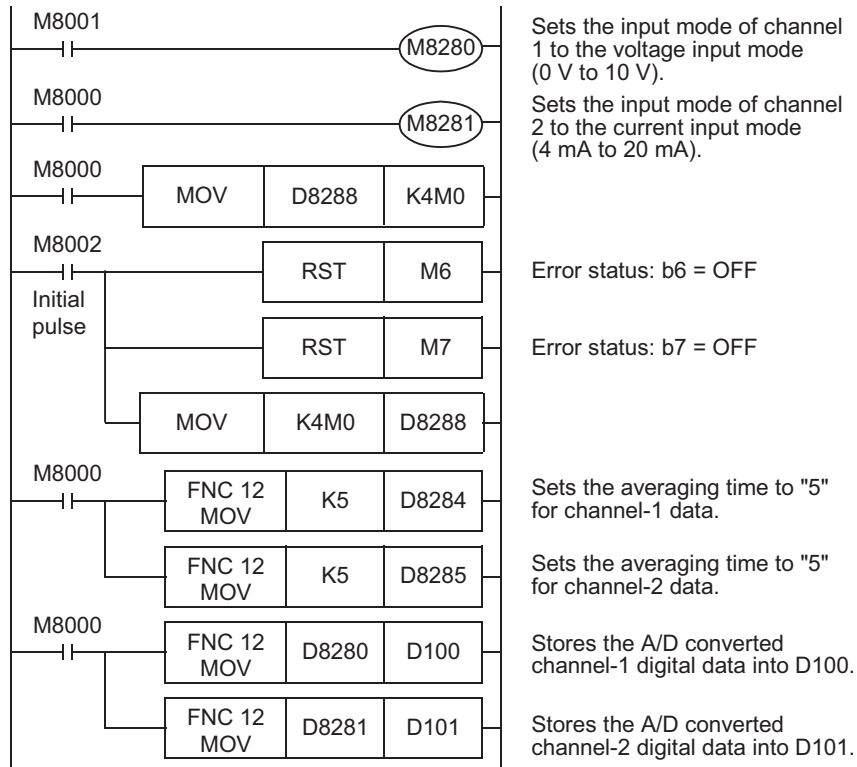

Even if the input data is not stored into D100 or D101, the data registers D8280 or D8281 can be directly used in the timer/counter setting value or in a PID instruction.

*1. "1st" for the FX3G PLC.

- For FX3U, FX3UC Series PLC

The following program will set channel 1 of the 1st adapter to voltage input mode and channel 2 to current input mode, and will store the converted A/D value of channel-1 data into D100 and that of channel-2 data into D101.

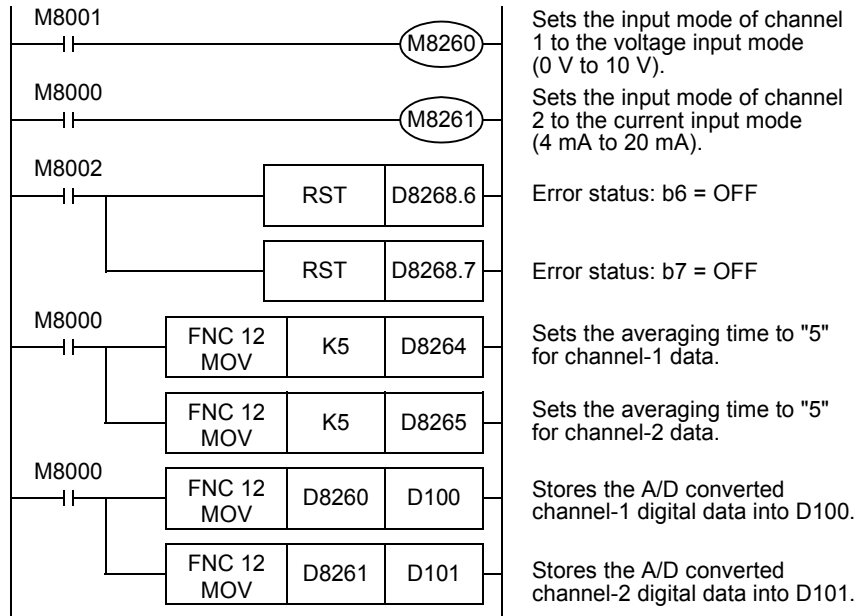

Even if the input data is not stored into D100 or D101, the data registers D8260 or D8261 can be directly used in the timer/counter setting value or in a PID instruction.

A	Common Items
B	FX3U-4AD FX3UC-4AD
C	FX3U-4AD-ADP
D	FX3G-2AD-BD
E	FX3U-4DA
F	FX3U-4DA-ADP
G	FX3G-1DA-BD
H	FX3U-3A-ADP
I	FX3U-4AD-PT -ADP
J	FX3U-4AD-PTW -ADP

5. Changing of Input Characteristics

Use the scaling instruction (SCL/FNC 259) for the FX3U/FX3UC Series PLC to change the input characteristics. FX3G Series PLCs do not support the scaling instruction. Use sequence programs to change the input characteristics.

→ For a detailed description of scaling instruction, refer to the **FX3G/FX3U/FX3UC Series Programming Manual - Basic & Applied Instruction Edition**.

5.1 Example: Changing of Voltage Input Characteristics

In the example explained in this section, the voltage input data "1 to 5 V" (Digital output value: 400 to 2000) is changed to the digital output value "0 to 10000".

1. Input characteristics

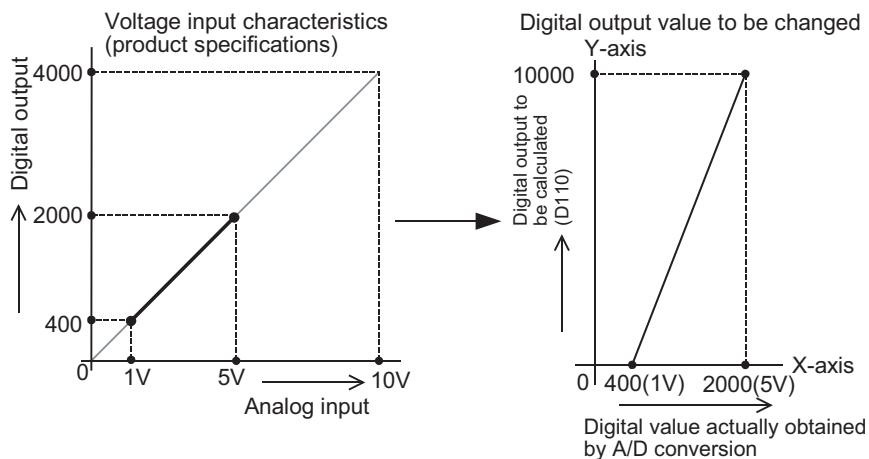

2. Example of program 1 (For FX3U, FX3UC Series PLC)

- For example, create the following program to change the digital input data of the 1st analog special adapter:

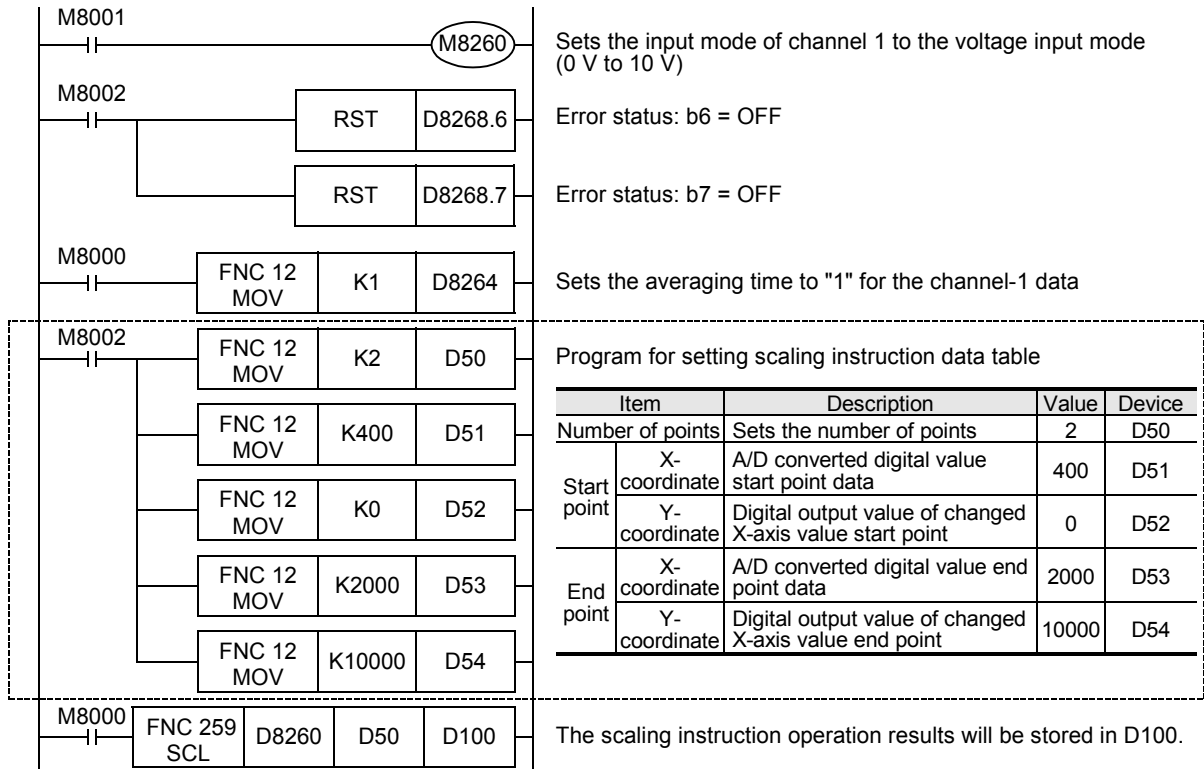

3. Example of program 2 (For FX3G Series PLC)

- For example, create the following program to change the digital input data (D110) of the 1st analog special adapter:

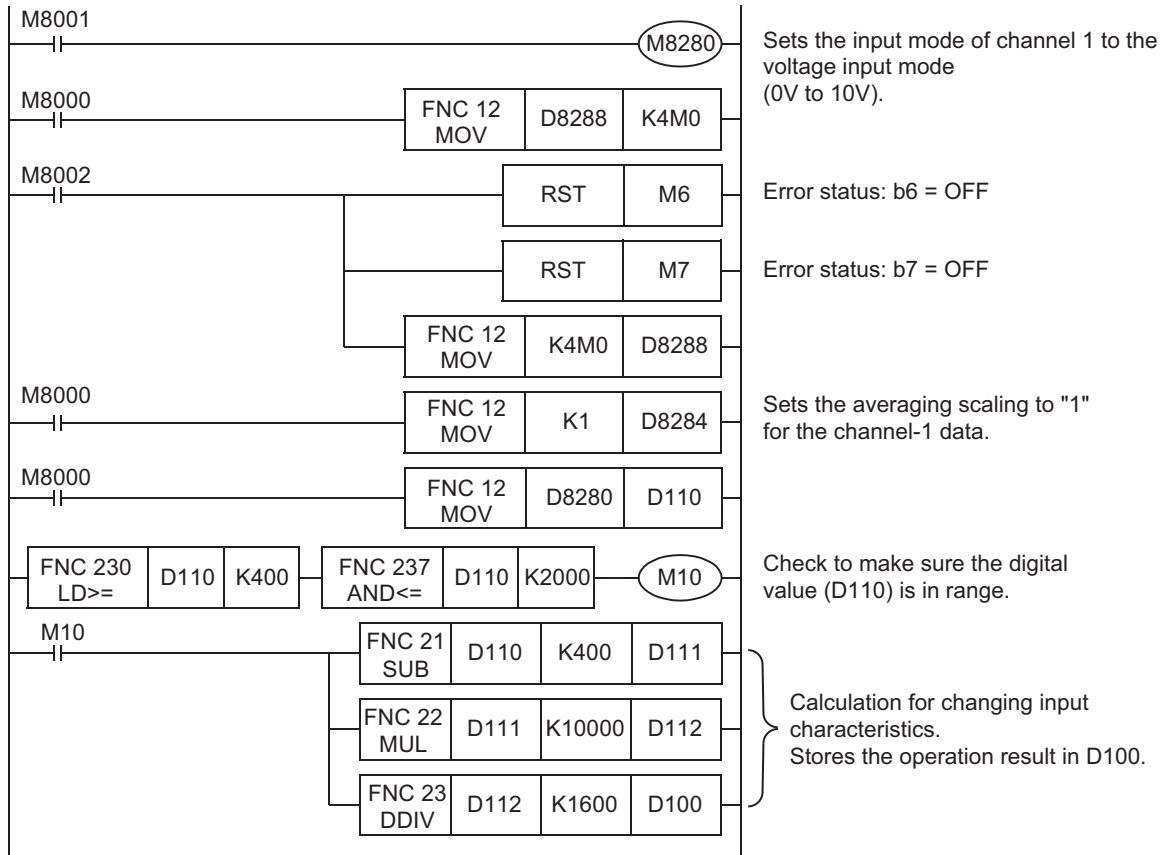

4. Cautions regarding programming

- GX Developer version 8.13P or later supports scaling instruction (SCL/FNC 259).
- If the A/D converted digital value is out of the data table range specified by the scaling instruction (SCL/FNC 259), the FX Series PLC will detect an operation error (error code: K6706).

6. Troubleshooting

This chapter describes troubleshooting methods and error statuses.

If the A/D conversion data is not input, or if the proper digital value is not input, check the following items:

- PLC version number
- Wiring
- Special devices
- Programs
- Error status

6.1 PLC Version Number Check

- Any versions (from Ver.2.20 (initial version) to the latest version) of the FX3U Series are compatible.
- Check the version number of the FX3UC Series PLC. The version number should be 1.20 or later.
- Any versions (from Ver.1.00 (initial version) to the latest version) of the FX3G Series are compatible.
→ For a detailed description of the version number check method, refer to Section 1.3.

6.2 Wiring Check

Check the following items for wiring:

1. Power

The 4AD-ADP needs driving power. Verify that the power supply line is properly connected. Also check that the POWER indicator lamp of the 4AD-ADP is on.

2. Analog input line

Use 2-core twisted shielded pair cable for the analog input line. In addition, be sure to separate the analog input line from other power lines or inductive lines.

3. Use of current input mode

To use the current input mode for a channel, be sure to shortcircuit the line between the V \square + terminal and the I \square + terminal (\square : channel number) of the channel. If the line is not shortcircuited, data will not be converted into proper digital data.

→ For a detailed description of wiring, refer to Chapter 3.

6.3 Special Device Check

Check whether the special devices for the 4AD-ADP are being used correctly:

1. Input mode switching

Check that the special device for switching the input mode is set correctly.

Turn off the device to set the input mode to the voltage input mode. Turn on the device to set the input mode to the current input mode.

2. Input data

Verify that the special device of the selected channel is correctly selected. This special device should be selected depending on the connecting position and the channel.

3. Averaging time

Check that the set averaging time is within the specified range. The averaging time should be set in the range from 1 to 4095. If the set averaging time is outside the specified range, an error occurs.

4. Error status

Check that no error is detected in the 4AD-ADP.

If an error is detected, check the details of the error, and then check the wiring and programs.

→ **For a detailed description of special devices, refer to Chapter 4.**

6.4 Program Check

Check the following items for the program:

1. Clearing of error status at power on

When the power is turned off and then on again, the error status should be cleared (b6 and b7 should turn off) using the program.

2. Check of storage devices

Verify that different values are not being stored in the same device by other parts of the program.

6.5 Error Status Check

If an error occurs in the 4AD-ADP, the corresponding bit will turn ON.
 The bit which is turned ON due to the error status is held ON until overwritten to OFF by the program or the power is cycled. If b6 or b7 is turned ON, then it is necessary to clear the error status using the program the next time the power of the PLC is cycled.

Bit	Description	Bit	Description
b0	Channel-1 over-scale detection	b7	4AD-ADP communication data error
b1	Channel-2 over-scale detection	b8	Channel-1 under-scale detection*1
b2	Channel-3 over-scale detection	b9	Channel-2 under-scale detection*1
b3	Channel-4 over-scale detection	b10	Channel-3 under-scale detection*1
b4	EEPROM error	b11	Channel-4 under-scale detection*1
b5	Averaging time setting error	b12 to b15	Unused
b6	4AD-ADP hardware error (Power supply error included)	-	-

*1. The FX3U/FX3UC Series PLC Ver.2.70 or later supports the under-scale detection function. The under-scale detection function is valid only for current input mode.

To solve the problem, refer to the troubleshooting method described below:

1. Over-scale detection (b0 to b3)

- 1) Description of error
 The input analog value (voltage or current value) is outside the specified range.
 Voltage input mode : The input voltage value is over the specified upper limit of 10.2 V.
 Current input mode : The input current value is over the specified upper limit of 20.4 mA.
- 2) Remedy
 Check that the input analog value is within the specified range. Also check the wiring.

2. EEPROM error (b4)

- 1) Description of error
 The adjustment data which was set in the EEPROM before delivery from our factory cannot be read out properly or has been destroyed.
- 2) Remedy
 Please contact the nearest Mitsubishi Electric distributor office.

3. Averaging time setting error (b5)

- 1) Description of error
 The averaging time set for one of the channels (channels 1 to 4) is outside the specified range: 1 to 4095.
- 2) Remedy
 Check that the averaging time is set correctly for each channel.

4. 4AD-ADP hardware error (b6)

- 1) Description of error
 The 4AD-ADP is not operating properly.
- 2) Remedy
 Check that the 24V DC power is properly supplied to the 4AD-ADP. Also check that the 4AD-ADP is correctly connected to the PLC.
 If the problem cannot be solved even after the above check, please contact the nearest Mitsubishi Electric distributor office.

5. 4AD-ADP communication error (b7)

- 1) Description of error
A communication error is detected between the 4AD-ADP and the PLC.
- 2) Remedy
Check that the 4AD-ADP is correctly connected to the PLC.
If the problem cannot be solved even after the above check, please contact the nearest Mitsubishi Electric distributor office.

6. Under-scale detection (b8 to b11)

- 1) Description of error
The input analog value (current value) is below the specified lower limit.
This error is only detected for the current input mode, and indicates the input current is less than 2 mA.
- 2) Remedy
Check that the input analog value is within the specified range. Also check the wiring.

FX3G/FX3U/FX3UC Series Programmable Controllers

User's Manual [Analog Control Edition] FX3G-2AD-BD (2-channel analog Input)

Foreword

This manual describes the specifications, wiring, and operation methods for the FX3G-2AD-BD analog input expansion board (2-channel analog input) and should be read and understood before attempting to install or use the unit.

Store this manual in a safe place so that you can take it out and read it whenever necessary. Always forward it to the end user.

This manual confers no industrial property rights or any rights of any other kind, nor does it confer any patent licenses. Mitsubishi Electric Corporation cannot be held responsible for any problems involving industrial property rights which may occur as a result of using the contents noted in this manual.

© 2005 MITSUBISHI ELECTRIC CORPORATION

A
Common Items

B
FX3U-4AD
FX3UC-4AD

C
FX3U-4AD-ADP

D
FX3G-2AD-BD

E
FX3U-4DA

F
FX3U-4DA-ADP

G
FX3G-1DA-BD

H
FX3U-3A-ADP

I
FX3U-4AD-PT
-ADP

J
FX3U-4AD-PTW
-ADP

1. Outline

This chapter outlines the FX3G-2AD-BD (referred to as the 2AD-BD).

1.1 Outline of Functions

The FX3G-2AD-BD is an analog expansion board. Connect the FX3G-2AD-BD to the FX3G Series PLC to read 2 channels of voltage/current data.

- 1) Up to 2*1 2AD-BD units can be connected to the FX3G Series PLC.
 (including the other analog expansion board, analog special adapters).
- 2) Either "voltage input" or "current input" can be specified for each channel.
- 3) A/D conversion data of each channel will be automatically written to the special data register of the FX3G Series PLC.

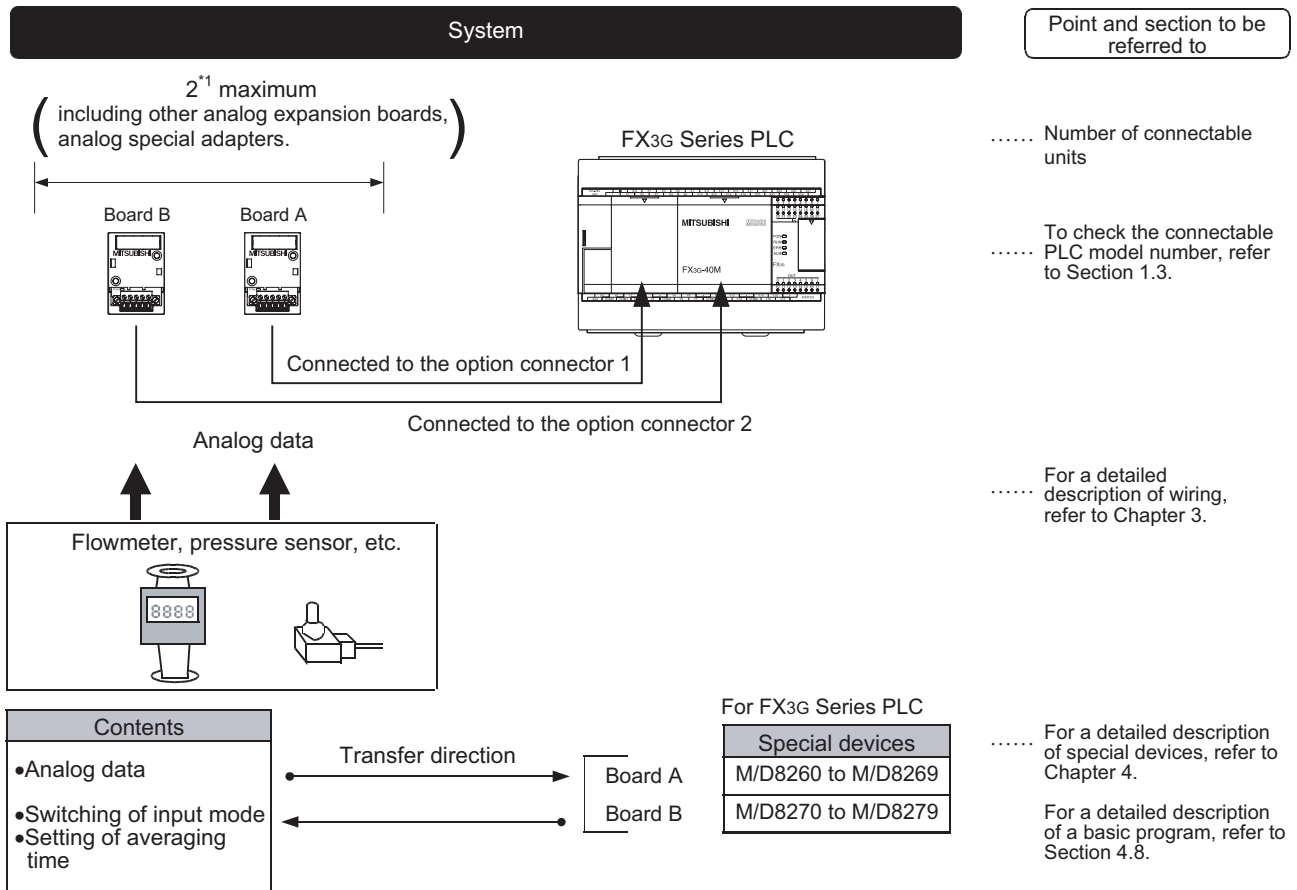

Refer to the system configuration shown in the User's Manual - Hardware Edition to check the number of connectable units and to configure the entire system.

*1. Only 1 analog board can be connected to the FX3G Series PLC (14-point and 24-point type).

1.2 Setup Procedure Before Starting Operation

Before starting analog input using the 2AD-BD, follow the procedure below to set up the system:

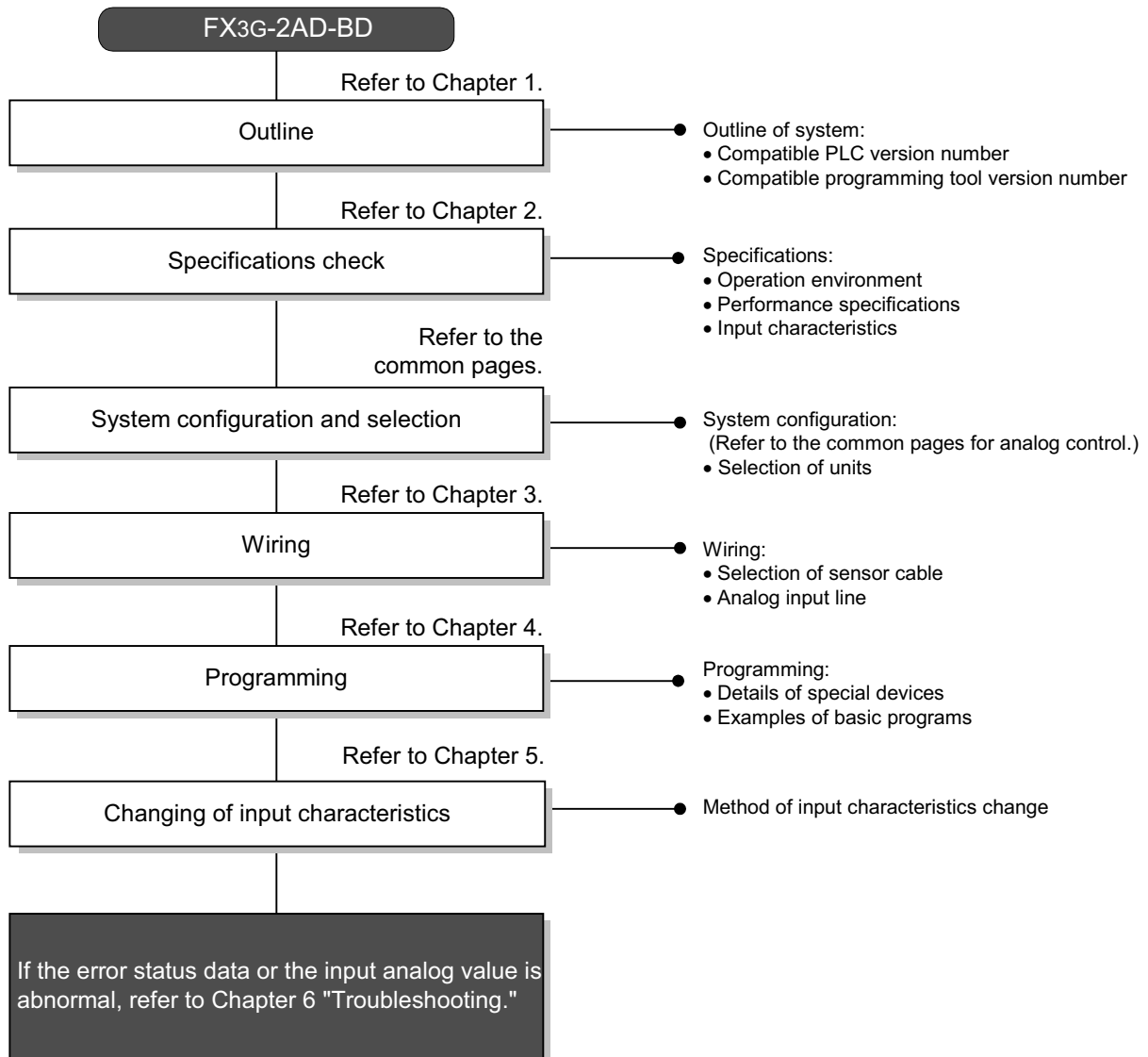

1.3 Connectable PLCs and Version Number

The 2AD-BD is compatible with the following PLC.

Compatible PLC	Version number	Date of production
FX3G Series PLC	Ver.1.10 or later	After October 2008 (initial production)

1. Version check

Special data register D8001 contains information for determining the PLC version number.

→ For a detailed description of the version check, refer to A. Common Items Subsection 5.1.2.

2. How to check the manufacturer's serial number

The year and month of production of the product can be checked on the nameplate, and on the front of the product.

→ For a detailed description of how to check the manufacturer's serial number, refer to A. Common Items Subsection 5.1.1.

1.4 Compatible Programming Tool Version Number

Use the programming tool with following version numbers to create programs for the 2AD-BD:

1. GX Works2

Software	Version number	Remarks
GX Works2 SW□DNC-GXW2-J	Ver. 1.07H or later	-
GX Works2 SW□DNC-GXW2-E	Ver. 1.08J or later	-

2. GX Developer

Software	Version number	Remarks
GX Developer • SW□D5C-GPPW-J • SW□D5C-GPPW-E	Ver. 8.72A or later	-

If a programming tool with the wrong version number is used, programming will not be possible.

3. FX-30P

Model name	Version number	Remarks
FX-30P	Ver. 1.00 or later	-

A
Common Items

B
FX3U-4AD
FX3UC-4AD

C
FX3U-4AD-ADP

D
FX3G-2AD-BD

E
FX3U-4DA

F
FX3U-4DA-ADP

G
FX3G-1DA-BD

H
FX3U-3A-ADP

I
FX3U-4AD-PT
-ADP

J
FX3U-4AD-PTW
-ADP

2. Specifications

This chapter describes the general and performance specifications for the 2AD-BD.

2.1 Generic Specifications

Item	Specifications				
Ambient temperature	0 to 55°C (32 to 131°F) when operating -25 to 75°C (-13 to 167°F) when stored				
Relative humidity	5 to 95%RH (no condensation) when operating				
Vibration resistance *1	DIN Rail Mounting	Frequency (Hz)	Acceleration (m/s ²)	Half amplitude (mm)	Tests 10 times in each direction (X-, Y-, and Z-axis directions) (Total: 80 min, each)
		10 - 57	-	0.035	
	Direct Mounting	57 - 150	4.9	-	
		10 to 57	-	0.075	
57 to 150	9.8	-			
Shock *1 resistance	147 m/s ² Acceleration, Action time: 11ms, 3 times by half-sine pulse in each direction X, Y, and Z				
Noise resistance	Using noise simulator of: Noise voltage: 1,000Vp-p / Noise width: 1μs / Rise: 1ns / Cycle: 30 to 100Hz				
Grounding	Class D grounding (grounding resistance: 100 Ω or less) <Common grounding with a heavy electrical system is not allowed.>*2				
Working environment	Free from corrosive or flammable gas and excessive conductive dusts				
Working altitude	< 2000m ^{*3}				

*1. The criterion is shown in IEC61131-2.

*2.

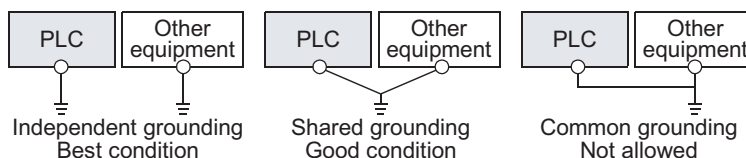

→ For a detailed description of the grounding, refer to Section 3.5.

*3. If the pressure is higher than the atmospheric pressure, do not use the 2AD-BD.
 The 2AD-BD may malfunction.

2.2 Performance Specifications

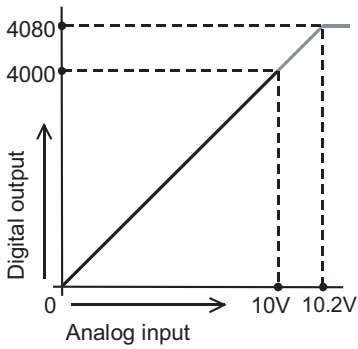
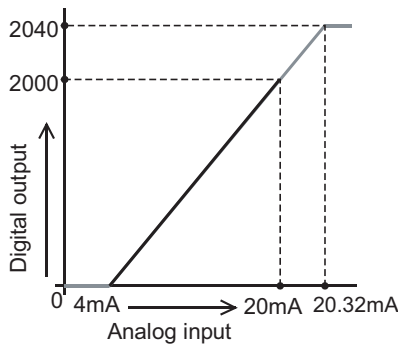
Item	Specifications	
	Voltage input	Current input
Analog input range	0V to 10V DC (Input resistance: 198.7 kΩ)	4mA to 20mA DC (Input resistance: 250 Ω)
Absolute input maximum	-0.5V, +15V	-2mA, +30mA
Digital output	12 bits, binary	11 bits, binary
Resolution	2.5mV (10V/4000)	8μA (16mA/2000)
Total accuracy	<ul style="list-style-type: none"> ±0.5% (±50mV) for 10V full scale (when ambient temperature is 25°C ± 5°C) ±1.0% (±100mV) for 10V full scale (when ambient temperature is 0°C to 55°C) 	<ul style="list-style-type: none"> ±0.5% (±80μA) for 16mA full scale (when ambient temperature is 25°C ± 5°C) ±1.0% (±160μA) for 16mA full scale (when ambient temperature is 0°C to 55°C)
A/D conversion time	180 μs (The data will be updated at every scan time.) → For a detailed description of data update, refer to Section 2.4.	
Input characteristics		
Insulation method	<ul style="list-style-type: none"> The analog input area is not insulated from the PLC. Channels are not insulated from each other. 	
Number of I/O points occupied	0 point (This number is not related to the maximum number of input/output points of the PLC.)	

A
Common Items

B
FX3U-4AD
FX3UC-4AD

C
FX3U-4AD-ADP

D
FX3G-2AD-BD

E
FX3U-4DA

F
FX3U-4DA-ADP

G
FX3G-1DA-BD

H
FX3U-3A-ADP

I
FX3U-4AD-PT-ADP

J
FX3U-4AD-PTW-ADP

2.3 A/D Conversion Time

This section describes the A/D conversion time.

1. A/D conversion and special data register update timing

A/D conversion is performed at every scan time of the PLC.

During execution of END instruction, the PLC performs A/D conversion, reads out the A/D converted data, and then writes the data in the special data registers.

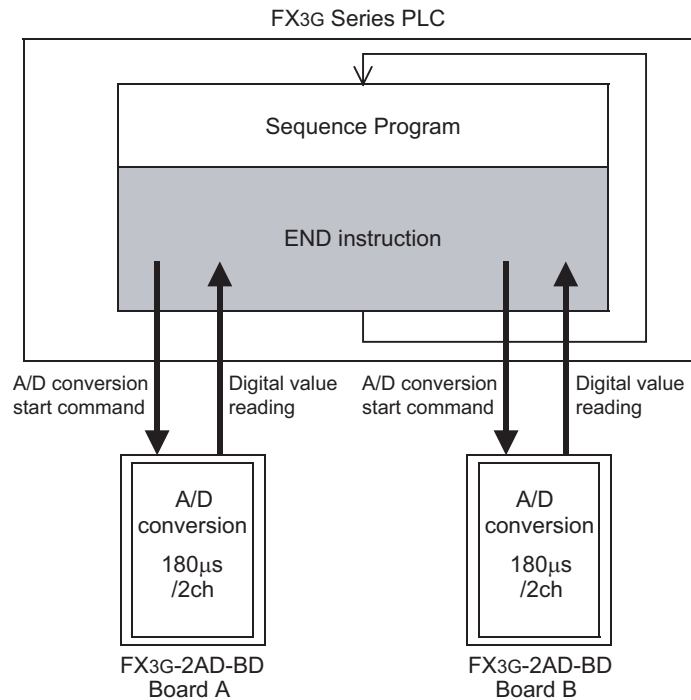

2. A/D conversion during PLC STOP

Even if the PLC is stopped, A/D conversion will be performed and the special data registers will be updated.

3. If two analog expansion boards are connected

During execution of the END instruction, data will be read out from all the connected boards (in the order of board A → board B).

4. A/D conversion speed (data update time)

During execution of END instruction, the A/D converted data of all 2 channels will be read out in 180µs, and the data read out will be written to the special data registers.

END instruction execution time will be "180µs × number of connected analog boards."

3. Wiring

This chapter describes the 2AD-BD wiring.
 Observe the following caution to wire the 2AD-BD.

WIRING PRECAUTIONS



- Make sure to cut off all phases of the power supply externally before attempting wiring work. Failure to do so may cause electric shock or damages to the product.

WIRING PRECAUTIONS



- Connect the DC power supply wiring to the dedicated terminals described in this manual. If an AC power supply is connected to a DC input/output terminal or DC power supply terminal, the PLC will be burnt out.
- Do not wire vacant terminals externally. Doing so may damage the product.
- Perform class D grounding (grounding resistance: 100Ω or less) to the grounding terminal on the main unit. Do not use common grounding with heavy electrical systems.
- When drilling screw holes or wiring, make sure cutting or wire debris does not enter the ventilation slits. Failure to do so may cause fire, equipment failures or malfunctions.
- Make sure to observe the following precautions in order to prevent malfunctions under the influence of noise:
 - Do not bundle the power line or twisted shielded cable together with or lay it close to the main circuit, high-voltage line, or load line. Otherwise, noise disturbance and/or surge induction are likely to take place. As a guideline, lay the control line at least 100mm (3.94") or more away from the main circuit, high-voltage line, or load line.
 - Ground the shield of the analog input/output cable at one point on the signal receiving side. However, do not use common grounding with heavy electrical systems.
- Make sure to properly wire to the European terminal board in accordance with the following precautions. Failure to do so may cause electric shock, equipment failures, a short-circuit, wire breakage, malfunctions, or damage to the product.
 - The disposal size of the cable end should follow the dimensions described in the manual.
 - Tightening torque should follow the specifications in the manual.
 - Twist the end of strand wire and make sure there are no loose wires.
 - Do not solder-plate the electric wire ends.
 - Do not connect more than the specified number of wires or electric wires of unspecified size.
 - Affix the electric wires so that neither the terminal block nor the connected parts are directly stressed.

A
Common Items

B
FX3U-4AD
FX3UC-4AD

C
FX3U-4AD-ADP

D
FX3G-2AD-BD

E
FX3U-4DA

F
FX3U-4DA-ADP

G
FX3G-1DA-BD

H
FX3U-3A-ADP

I
FX3U-4AD-PT
-ADP

J
FX3U-4AD-PTW
-ADP

3.1 Terminal Layout

The terminals of the 2AD-BD are arranged as follows:

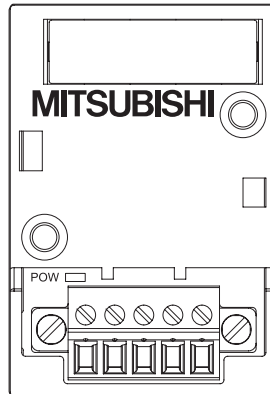

Signal	V1+	I1+	V2+	I2+	VI-
Application	Channel 1 analog input		Channel 2 analog input		COM terminal

3.2 Applicable Cables and Terminal Tightening Torque

Use the following cables to connect with the counterpart equipment. Terminate the cable ends as shown below.

1. Cables

Applicable cable and tightening torque

	Wire size (stranded/ single-wire)	Tightening torque	Termination
Single-wire	0.3mm ² to 0.5mm ² (AWG22 to 20)	0.22N•m to 0.25N•m	<ul style="list-style-type: none"> To connect a stranded cable, peel the cover off the cable and then twist the core before connection. To connect a single-wire cable, just strip the cover off the cable before connection. Rod terminal with insulation sleeve (recommended terminal) AI 0.5-8WH : Manufactured by Phoenix Contact Caulking tool CRIMPFOX 6*1 : Manufactured by Phoenix Contact (or CRIMPFOX 6T-F*2 : Manufactured by Phoenix Contact)
2-wire	0.3mm ² (AWG22)		
Rod terminal with insulation sleeve	0.3mm ² to 0.5mm ² (AWG22 to 20) (Refer to the rod terminal external view shown in the following figure.)		

- *1. Old model name : CRIMPFOX ZA 3
- *2. Old model name : CRIMPFOX UD 6

2. Termination of cable end

To terminate the cable, treat the stranded/single-wire directly or use a rod terminal with insulation sleeve.

- To directly terminate the end of a stranded/single-wire cable:
 - Twist the end of the stranded cable so that the "barbed wires" cannot protrude.
 - Do not solder-plate the end of the cable.
- To terminate cable end using a rod terminal with insulation sleeve:
 If the cable cover is too thick, it may be difficult to insert the cable into the insulation sleeve. For this reason, select an appropriate cable while referring to the external view.
 <Reference>

Termination of cable end

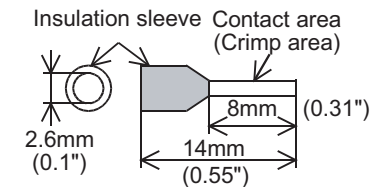
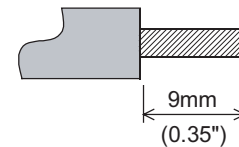

Manufacturer	Model	Caulking tool
Phoenix Contact	AI 0.5-8WH	CRIMPFOX 6*3 (or CRIMPFOX 6T-F*4)

- *3. Old model name : CRIMPFOX ZA 3
- *4. Old model name : CRIMPFOX UD 6

3. Tool

- To tighten terminals, use a small-sized screwdriver whose head is straight and is not widened as shown in the figure to the right.

Note:

If the diameter of screwdriver grip is too small, tightening torque will not be able to be achieved. To achieve the appropriate tightening torque shown in the table above, use the following screwdriver or an appropriate replacement (grip diameter: approximately 25mm (0.98")).
 <Reference>

Manufacturer	Model
Phoenix Contact	SZS 0.4×2.5

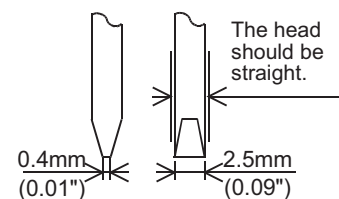

3.3 Analog Input Line

For analog input, "voltage input" or "current input" can be selected for each channel.

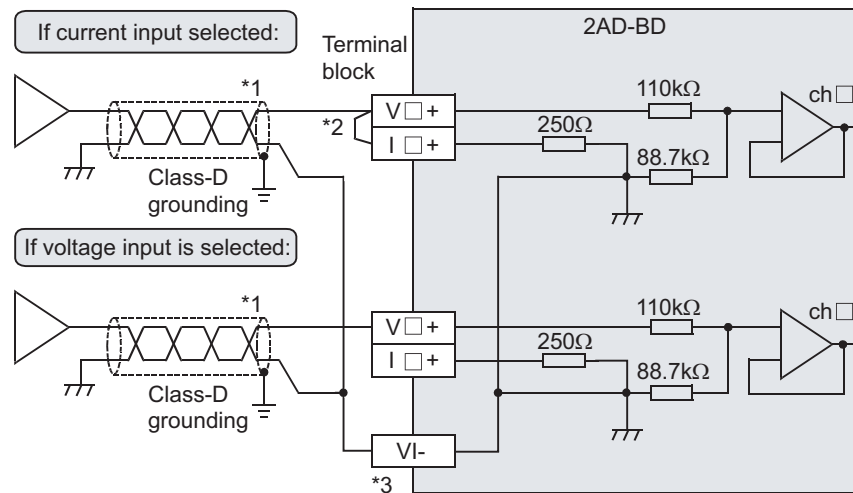

V□+, I□+, ch□:□ represents the channel number.

- *1. Use the 2-core shielded twisted pair cable for the analog input lines, and separate the analog input lines from other power lines or inductive lines.
- *2. If "current input" is selected, be sure to short the line between the V□+ terminal and the I□+ terminal. (□: Channel number).
- *3. Make sure to short-circuit the "V□+" and "VI-" terminals when ch is not used.

3.4 Grounding

Grounding should be performed as stated below.

- The grounding resistance should be 100Ω or less.
- Independent grounding should be performed for best results.
 When independent grounding is not performed, perform "shared grounding" as shown in the following figure.

→ For details, refer to the User's Manual - Hardware Edition of the PLC Series.

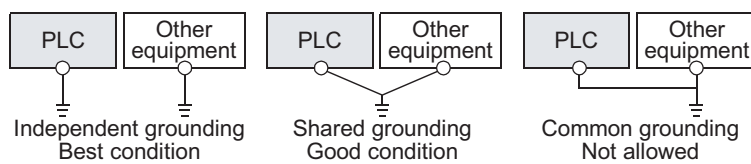

- The grounding wire size should be AWG22 to 20 (0.3 to 0.5 mm²).
- The grounding point should be close to the PLC, and all grounding wires should be as short as possible.

4. Programming

This chapter describes how to create programs that can read analog data using the 2AD-BD.

4.1 Loading of A/D Conversion Data

- 1) The input analog data will be converted into digital data and then stored in the special devices of the FX3G Series PLC.
- 2) If the data is stored in the special devices, the averaging time can be set, and the input mode can be specified.
- 3) Special auxiliary relays (10 points) and special data registers (10 points) are assigned respectively to the analog expansion board (board A) connected to option connector 1 and the analog expansion board (board B) connected to option connector 2 in this order.

→ For a detailed description of special device assignment, refer to Section 4.2.

- FX3G Series PLC

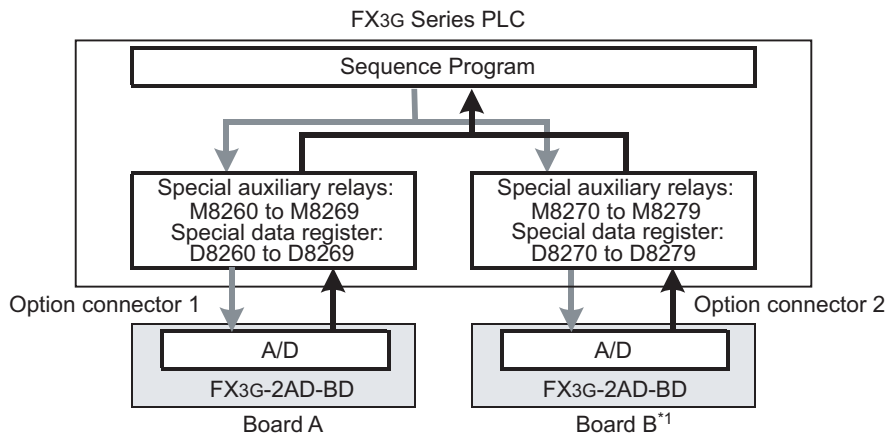

The analog expansion board connected to option connector 1 is regarded as the "board A", and the analog expansion board connected to option connector 2 is regarded as the "board B".

- *1. Board B is not available in the FX3G Series PLC (14-point and 24-point type).

4.2 List of Special Devices

If the 2AD-BD is connected, special devices will be assigned automatically as shown in the following table:
 R: Read / W: Write

Special device	Device number		Description	Attribute	Reference
	Board A	Board B			
Special auxiliary relay	M8260	M8270	Switches the input mode of channel 1	R/W	Section 4.3
	M8261	M8271	Switches the input mode of channel 2	R/W	
	M8262 to M8269	M8272 to M8279	Unused (Do not use.)	-	-
Special data register	D8260	D8270	Channel-1 input data	R	Section 4.4
	D8261	D8271	Channel-2 input data	R	
	D8262	D8272	Unused (Do not use.)	-	-
	D8263	D8273			
	D8264	D8274	Averaging time for channel-1 (Setting range: 1 to 4095)	R/W	Section 4.5
	D8265	D8275	Averaging time for channel-2 (Setting range: 1 to 4095)	R/W	
	D8266	D8276	Unused (Do not use.)	-	-
	D8267	D8277			
	D8268	D8278	Error status	R/W	Section 4.6
D8269	D8279	Model code = 3	R	Section 4.7	

4.3 Switching of Input Mode

Turn the special auxiliary relay on/off to switch the input mode of 2AD-BD between the current input mode and the voltage input mode.

To switch the input mode, use the following special auxiliary relays:

Special auxiliary relay		Description	
Board A	Board B		
M8260	M8270	Switches the input mode of channel 1	OFF: Voltage input
M8261	M8271	Switches the input mode of channel 2	ON: Current input

1. Program Example

To switch the channel input mode, create a sequence program as follows:

- 1) To switch the input mode of channel 1 of the board A to the voltage input mode:
- 2) To switch the input mode of channel 2 of the board A to the current input mode:

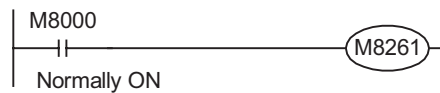
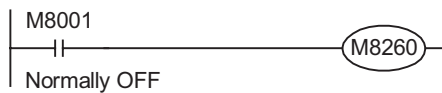

4.4 Input Data

Numeric data type: Decimal (K)

The data converted by the 2AD-BD will be stored in the special data registers.
 The special data registers that store the input data are shown in the following table:

Special data register		Description
Board A	Board B	
D8260	D8270	Stores the channel-1 input data
D8261	D8271	Stores the channel-2 input data

The converted A/D immediate data or averaged data (data average conforming to the specified averaging time) will be stored in the above data registers as the input data.

→ For a detailed description of the averaging time, refer to Section 4.5.

1. Caution regarding input data

Input data is for reading only.

Do not change (rewrite) the input data using sequence program, indicator, or device monitor of the programming tool.

2. Program Example

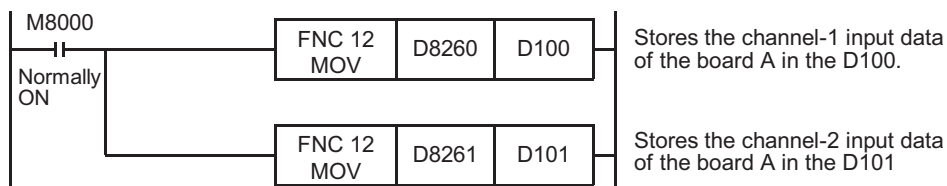

Stores the channel-1 input data of the board A in the D100.

Stores the channel-2 input data of the board A in the D101

Even if the input data is not stored in D100 or D101, data registers D8260 or D8261 can be directly used in the timer/counter set value or in a PID instruction.

4.5 Averaging Time

Setting range: 1 to 4095

Initial value: K1

Numeric data type: Decimal (K)

If the averaging time is set for the 2AD-BD, the average data will be stored as the input data. The averaging time can be set for each channel.

Set the averaging time in the following special data registers:

Special data register		Description
Board A	Board B	
D8264	D8274	Averaging time for channel-1 data
D8265	D8275	Averaging time for channel-2 data

1. Cautions regarding averaging time setting

- If the averaging time is set to "1", the immediate data is stored to the special data register.
- If the averaging time is set in the range from 2 to 4095, the average value will be calculated to conform to the set averaging time, and the average value obtained will be stored in the special data register.
- After turning the PLC power on, the current data is stored to special data registers until the number of data items reaches the set averaging time. After this, the average data will be stored.
- Set the averaging time in the range from 1 to 4095. If the set value is outside the setting range, an error signal will be output.
- If the averaging time is set to "0" or smaller, the PLC will perform as if the averaging time is set to "1".
 If the averaging time is set to "4096" or larger, the PLC will perform as if the averaging time is set to "4096".
 → **For a detailed description of the error status, refer to Section 6.5**

2. Program Example

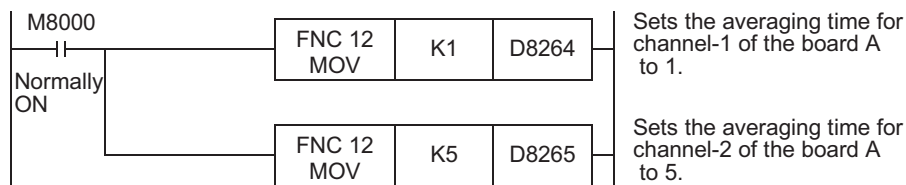

4.6 Error Status

If an error is detected in the 2AD-BD, the error status data will be stored in the corresponding special data register.

The following table shows the special data registers that store the error status data:

Special data register		Description
Board A	Board B	
D8268	D8278	Stores the error status data.

Check the ON/OFF status of each bit of the error status data register to check the description of the error. Errors are assigned to the bits as shown in the following table. Create a program to detect errors.

→ For a detailed description of the error status, refer to Section 6.5.

Bit	Description	Bit	Description
b0	Channel-1 over-scale detection	b5	Averaging time setting error
b1	Channel-2 over-scale detection	b6	2AD-BD hardware error
b2	Unused	b7	2AD-BD communication data error
b3	Unused	b8 to b15	Unused
b4	EEPROM error	-	-

1. Caution regarding use of error status data

If a 2AD-BD hardware error (b6) or 2AD-BD communication data error (b7) is detected, it is necessary to clear the error status with a program at the next power-on of the PLC.

For this reason, be sure to create the following program:

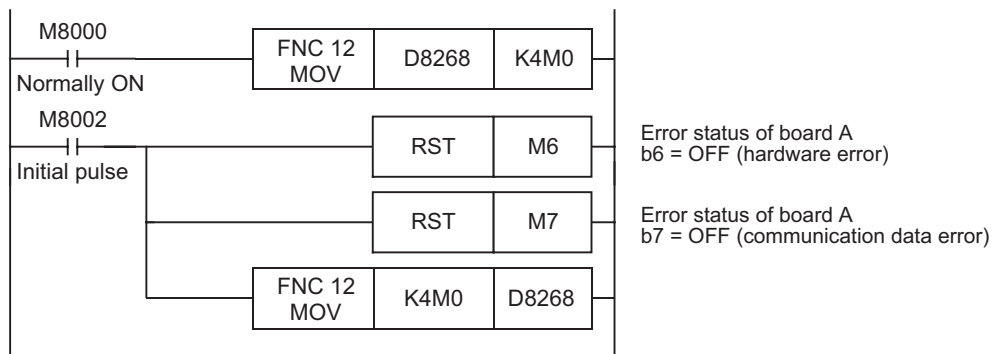

2. Program Example

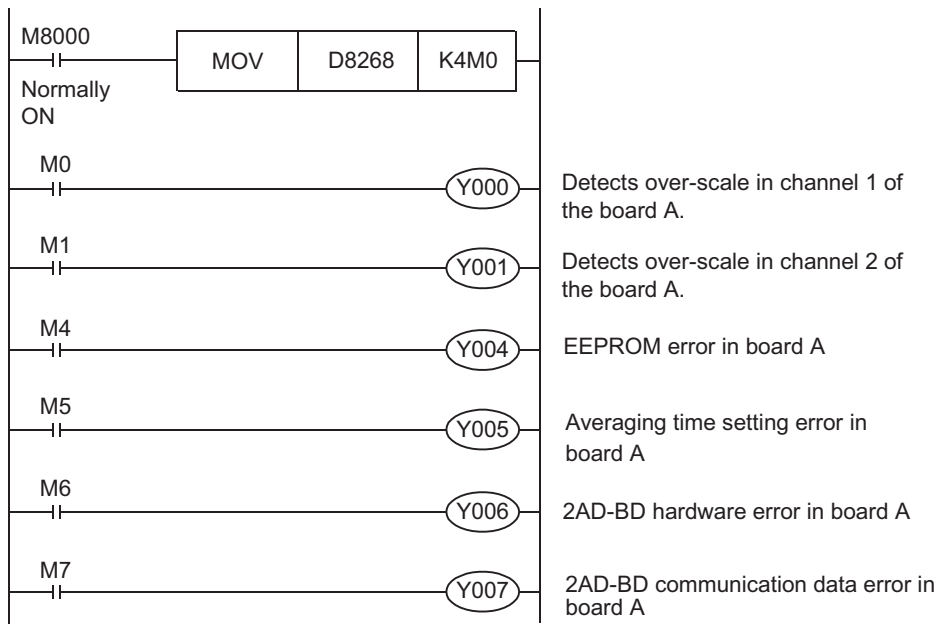

4.7 Model Code

Initial value: K3
Numeric data type: Decimal (K)

When the 2AD-BD is connected, model code "3" is stored in the corresponding special data register.
 The following table shows the special data registers that store the model code:

Special data register		Description
Board A	Board B	
D8269	D8279	Model code

Use the special data registers above to check whether a 2AD-BD is connected or not.

1. Program Example

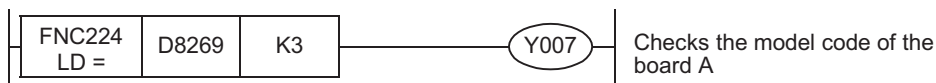

4.8 Basic Program Example

Create the following basic program example to read out analog conversion (A/D conversion) data.
 The following program will set the board A to voltage input mode and channel 2 to current input mode, and will store the converted A/D value of channel-1 data into D100 and that of channel-2 data into D101.

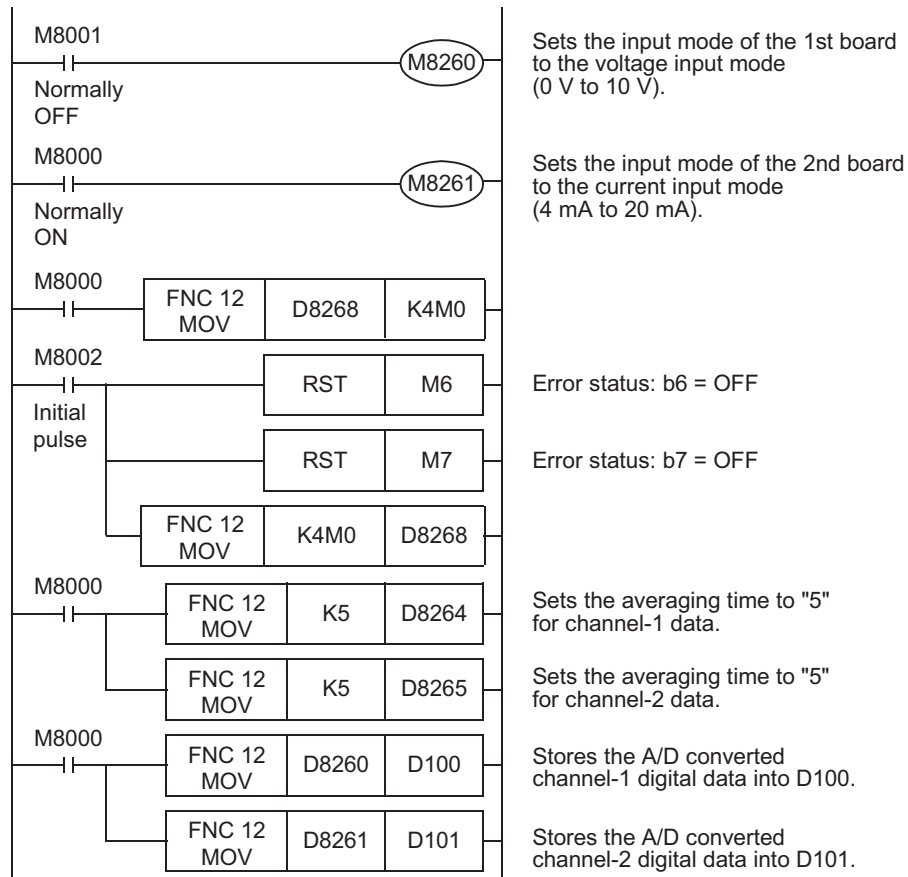

Even if the input data is not stored into D100 or D101, the data registers D8260 or D8261 can be directly used in the timer/counter setting value or in a PID instruction.

5. Changing of Input Characteristics

The input characteristics can be changed using sequence programs in FX3G Series PLCs.

5.1 Example: Changing of Voltage Input Characteristics

This section describes an example of a program that can change the digital output range of 400 to 2000 (when the voltage input is 1 to 5V) to the digital output range of 0 to 10000.

1. Input characteristics

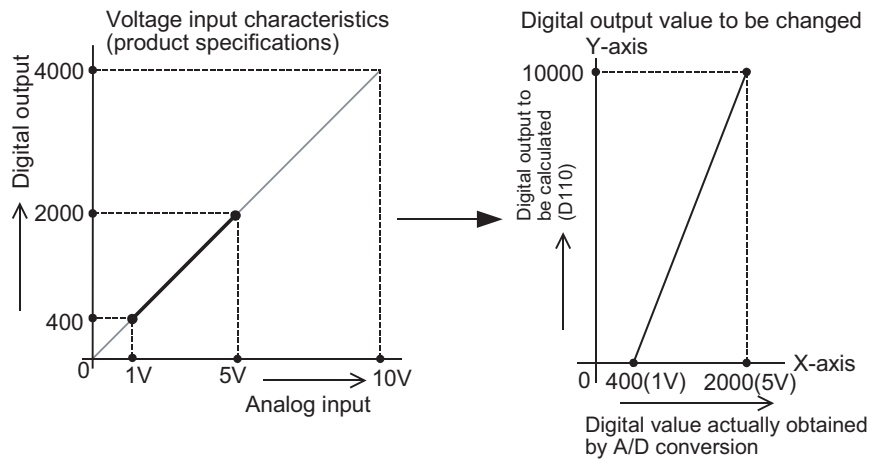

2. Example of program

For example, create the following program to change the digital input data of the board A:

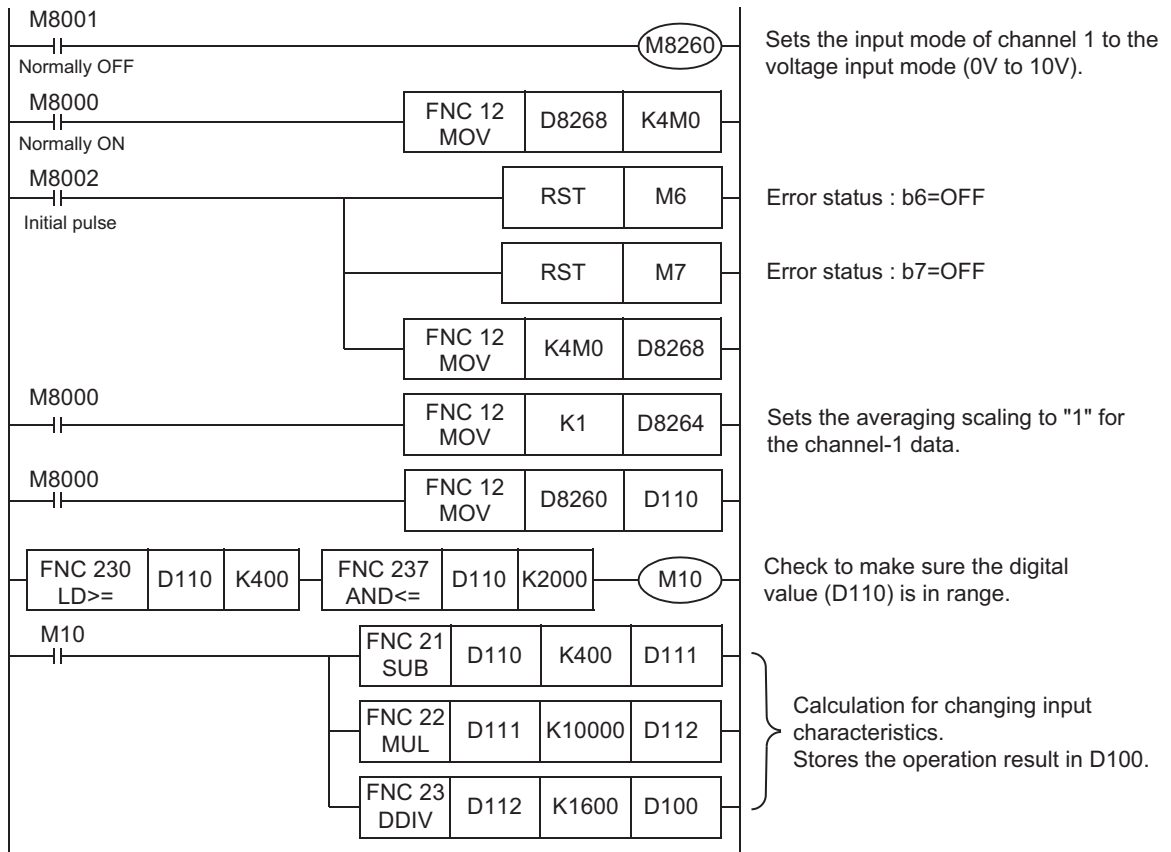

6. Troubleshooting

This chapter describes troubleshooting methods and error statuses.

If the A/D conversion data is not input, or if the proper digital value is not input, check the following items:

- PLC version number
- Installation
- Wiring
- Special devices
- Programs
- Error status

6.1 PLC Version Number Check

- Check the version number of the FX3G Series PLC. The version number should be 1.10 or later.
→ For a detailed description of the version number check method, refer to Section 1.3.

6.2 Checking Installation

- Confirm that the 2AD-BD is attached correctly to the main unit. Confirm also that the POW indicator lamp of the 2AD-BD is lit correctly.
→ For a detailed description of installing, refer to FX3G Series User's Manual - Hardware Edition.

6.3 Wiring Check

Check the following items for wiring:

1. Analog input line

Use 2-core twisted shielded pair cable for the analog input line. In addition, be sure to separate the analog input line from other power lines or inductive lines.

2. Use of current input mode

To use the current input mode for a channel, be sure to shortcircuit the line between the V \square + terminal and the I \square +terminal (\square : channel number) of the channel. If the line is not shortcircuited, data will not be converted into proper digital data.

→ For a detailed description of wiring, refer to Chapter 3.

6.4 Special Device Check

Check whether the special devices for the 2AD-BD are being used correctly:

1. Input mode switching

Check that the special device for switching the input mode is set correctly.

Turn off the device to set the input mode to the voltage input mode. Turn on the device to set the input mode to the current input mode.

2. Input data

Verify that the special device of the selected channel is correctly selected. This special device should be selected depending on the connecting position and the channel.

3. Averaging time

Check that the set averaging time is within the specified range. The averaging time should be set in the range from 1 to 4095. If the set averaging time is outside the specified range, an error occurs.

4. Error status

Check that no error is detected in the 2AD-BD.

If an error is detected, check the details of the error, and then check the wiring and programs.

→ For a detailed description of special devices, refer to Chapter 4.

6.5 Program Check

Check the following items for the program:

1. Clearing of error status at power on

When the power is turned off and then on again, the error status should be cleared (b6 and b7 should turn off) using the program.

2. Check of storage devices

Verify that different values are not being stored in the same device by other parts of the program.

6.6 Error Status Check

If an error occurs in the 2AD-BD, the corresponding bit will turn on.

The bit which is turned ON due to the error status is held ON until overwritten to OFF by the program or the power is cycled. If b6 or b7 is turned ON, then it is necessary to clear the error status using the program the next time the power of the PLC is cycled.

Bit	Description	Bit	Description
b0	Channel-1 over-scale detection	b5	Averaging time setting error
b1	Channel-2 over-scale detection	b6	2AD-BD hardware error
b2	Unused	b7	2AD-BD communication data error
b3	Unused	b8 to b15	Unused
b4	EEPROM error	-	-

To solve the problem, refer to the troubleshooting method described below:

1. Over-scale detection (b0, b1)

1) Description of error

The input analog value (voltage or current value) is outside the specified range.

The digital value is out of the range specified for the voltage input mode (0 to 4080) or outside the range specified for the current input mode (0 to 2040).

2) Remedy

Check that the input analog value is within the specified range. Also check the wiring.

2. EEPROM error (b4)

1) Description of error

The adjustment data which was set in the EEPROM before delivery from our factory cannot be read out properly or has been destroyed.

2) Remedy

Please contact the nearest Mitsubishi Electric distributor office.

3. Averaging time setting error (b5)

1) Description of error

The averaging time set for one of the channels (channels 1 to 2) is outside the specified range: 1 to 4095.

2) Remedy

Check that the averaging time is set correctly for each channel.

4. 2AD-BD hardware error (b6)

- 1) Description of error
The 2AD-BD is not operating properly.
- 2) Remedy
Check that the 2AD-BD is correctly connected to the PLC.
If the problem cannot be solved even after the above check, please contact the nearest Mitsubishi Electric distributor office.

5. 2AD-BD communication data error (b7)

- 1) Description of error
A communication error is detected between the 2AD-BD and the PLC.
- 2) Remedy
Check that the 2AD-BD is correctly connected to the PLC.
If the problem cannot be solved even after the above check, please contact the nearest Mitsubishi Electric distributor office.

A

Common Items

B

FX3U-4AD
FX3UC-4AD

C

FX3U-4AD-ADP

D

FX3G-2AD-BD

E

FX3U-4DA

F

FX3U-4DA-ADP

G

FX3G-1DA-BD

H

FX3U-3A-ADP

I

FX3U-4AD-PT-ADP

J

FX3U-4AD-PTW-ADP

MEMO

FX3G/FX3U/FX3UC Series Programmable Controllers

User's Manual [Analog Control Edition] FX3U-4DA (4-channel Analog Output)

Foreword

This manual describes the specifications, wiring, and operation methods for the FX3U-4DA special extension block (4-channel analog output) and should be read and understood before attempting to install or use the unit.

Store this manual in a safe place so that you can take it out and read it whenever necessary. Always forward it to the end user.

This manual confers no industrial property rights or any rights of any other kind, nor does it confer any patent licenses. Mitsubishi Electric Corporation cannot be held responsible for any problems involving industrial property rights which may occur as a result of using the contents noted in this manual.

© 2005 MITSUBISHI ELECTRIC CORPORATION

A
Common Items

B
FX3U-4AD
FX3UC-4AD

C
FX3U-4AD-ADP

D
FX3G-2AD-BD

E
FX3U-4DA

F
FX3U-4DA-ADP

G
FX3G-1DA-BD

H
FX3U-3A-ADP

I
FX3U-4AD-PT
-ADP

J
FX3U-4AD-PTW
-ADP

1. Outline

This chapter outlines the FX3U-4DA.

1.1 Outline of Functions

FX3U-4DA is an analog special function block which is connectable to the FX3G, FX3U or FX3UC Series PLC to convert 4-channel digital signal from the PLC to analog signal (voltage/current).

- 1) Up to 8^{*1} units can be connected to the FX3G/FX3U/FX3UC Series PLC. (including the other special function blocks).
- 2) Each channel has either Voltage Output or Current Output specification.
- 3) The block converts the digital values stored in the FX3U-4DA buffer memory (BFM) in FX3U-4DA to analog signals (voltage/current).
- 4) A predetermined output pattern is set as data table, and analog signal can be output according to the data table.

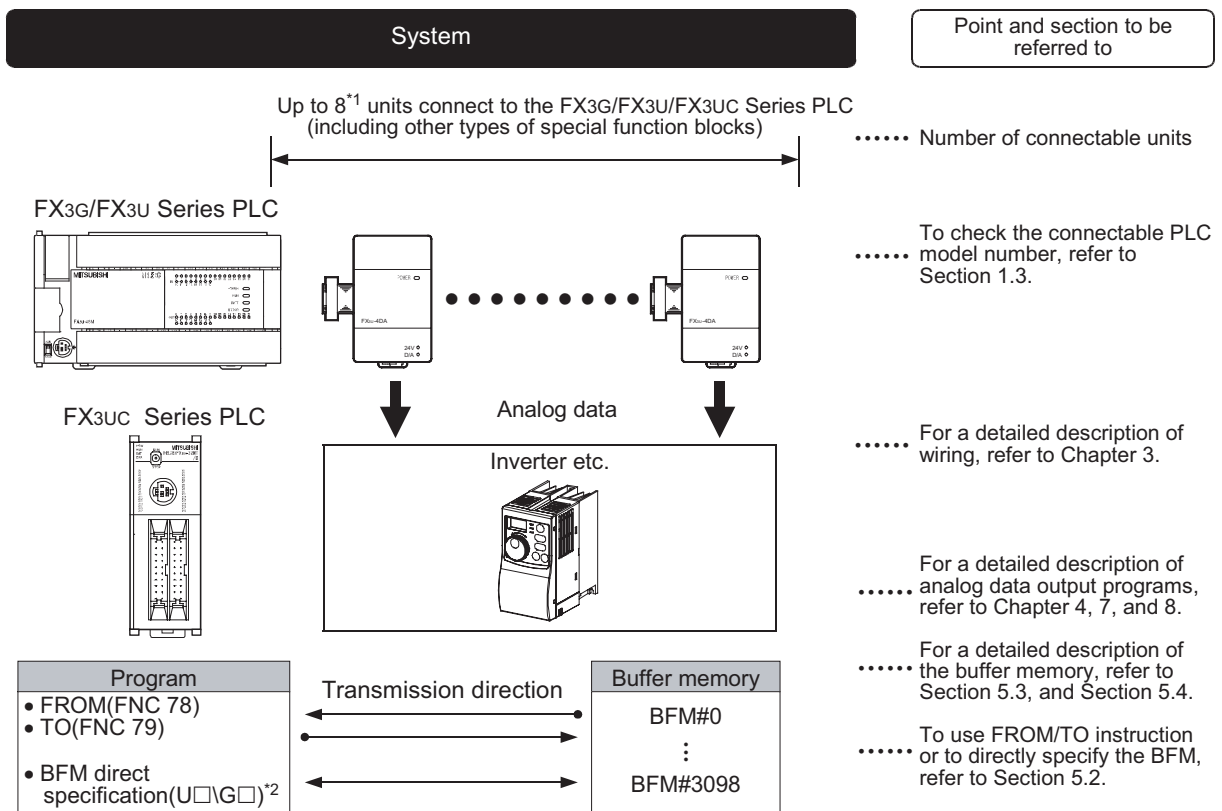

Refer to the system configuration shown in the FX3G/FX3U/FX3UC User's Manual - Hardware Edition to check the number of connectable units and to configure the entire system.

- *1. Up to 7 units can be connected to the FX3UC-32MT-LT(-2) PLC.
- *2. This function is only available for FX3U and FX3UC PLCs.

1.2 Setup Procedure Before Starting Operation

Before starting to use the FX3U-4DA, follow the procedure below to set up the system:

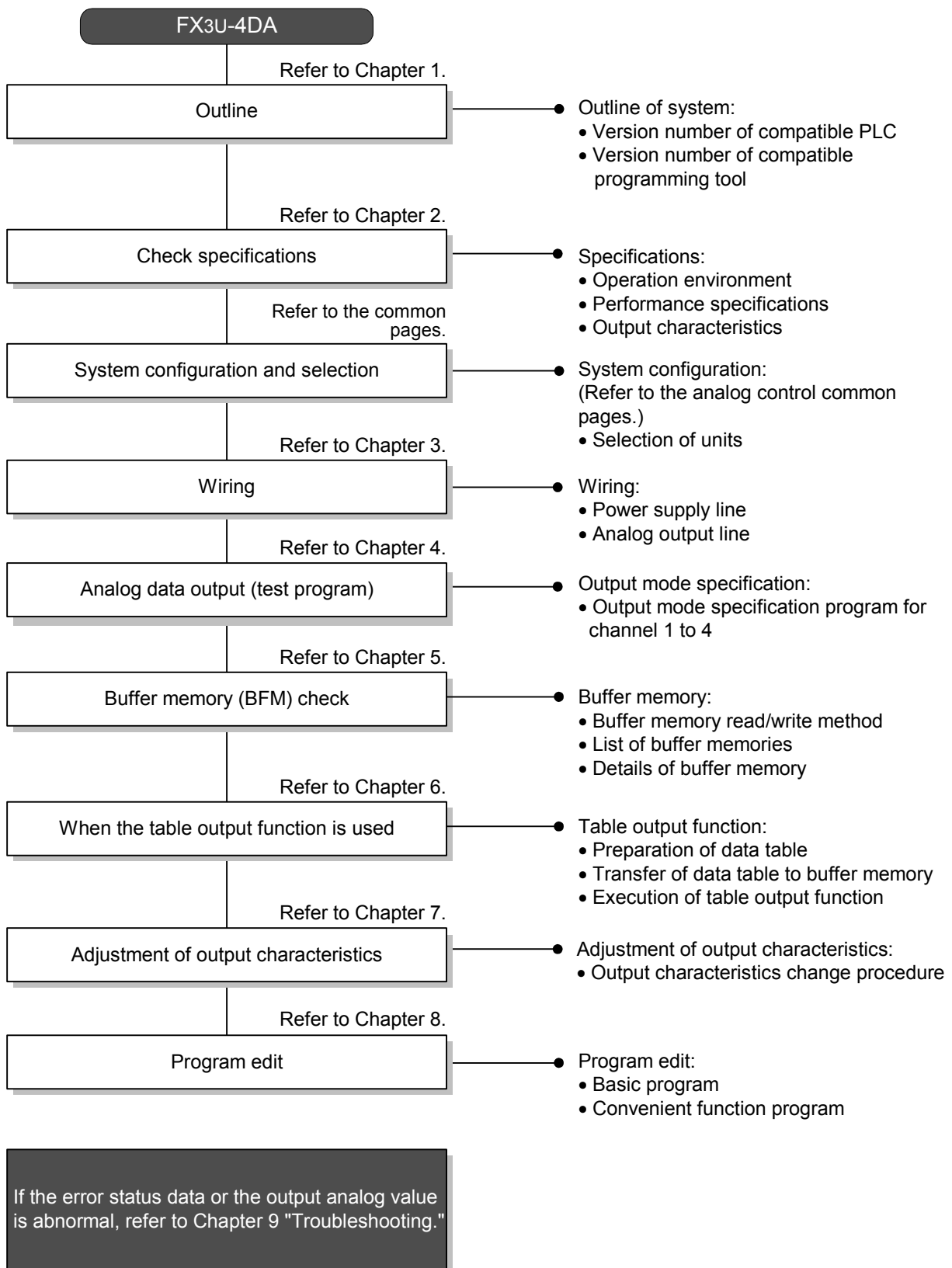

1.3 Connectable PLCs and Version Numbers

FX3U-4DA is compatible with the following PLC.

Compatible PLC	Version number	Date of production
FX3U Series PLC	Ver. 2.20 or later	from the first product
FX3UC Series PLC	Ver. 1.30 or later	August 2004 and later
FX3G Series PLC	Ver. 1.00 or later	from the first product

1. Version check

Special data register D8001 contains information for determining the PLC version.

→ For a detailed description of the version check, refer to A. Common Items Subsection 5.1.2.

2. How to check the manufacturer's serial number

The year and month of production of the product can be checked on the nameplate, and on the front of the product.

→ For a detailed description of how to check the manufacturer's serial number, refer to A. Common Items Subsection 5.1.1.

1.4 Compatible Programming Tool Version Number

Use a programming tool with the following version number to create FX3U-4DA programs for the FX3G/FX3U/FX3UC Series PLC.

1. GX Works2

Software	Version number	Remarks
GX Works2 SW□DNC-GXW2-J	Ver. 1.07H or later	-
GX Works2 SW□DNC-GXW2-E	Ver. 1.08J or later	-

2. GX Developer

- FX3U/FX3UC Series PLC

Software	Version number	Remarks
GX Developer SW□D5C-GPPW-J	Ver. 8.13P or later	When selecting the model, select FX3U(C)*1.
GX Developer SW□D5C-GPPW-E	Ver. 8.18U or later	

- FX3G Series PLC

Software	Version number	Remarks
GX Developer • SW□D5C-GPPW-J • SW□D5C-GPPW-E	Ver. 8.72A or later	-

If a programming tool with the wrong version number is used, programming will not be possible.

*1. For Ver. 8.13P to 8.24A of GX Developer, select FX3UC for the PLC type.

3. FX-30P

Model name	Version number	Remarks
FX-30P	Ver. 1.00 or later	-

2. Specifications

This chapter describes the general, power supply, and performance specifications for the FX3U-4DA.

2.1 Generic Specifications

Item	Specifications				
Ambient temperature	0 to 55°C (32 to 131°F) when operating -25 to 75°C (-13 to 167°F) when stored				
Relative humidity	5 to 95%RH (no condensation) when operating				
Vibration resistance *1	DIN Rail Mounting	Frequency (Hz)	Acceleration (m/s ²)	Half amplitude (mm)	Tests 10 times in each direction (X-, Y-, and Z-axis directions) (Total: 80 min, each)
		10 - 57	-	0.035	
	Direct Mounting *2	57 - 150	4.9	-	
		10 - 57	-	0.075	
Direct Mounting *2	57 - 150	9.8	-		
Shock resistance *1	147 m/s ² Acceleration, Action time: 11ms, 3 times by half-sine pulse in each direction X, Y, and Z				
Noise resistance	Using noise simulator of: Noise voltage: 1,000Vp-p / Noise width: 1μs / Rise: 1ns / Cycle: 30 to 100Hz				
Dielectric withstand voltage	500 V AC, for 1 min		Between batch of all terminals and ground terminal		
Insulation resistance	5MΩ or more using 500V DC insulation resistance meter				
Grounding	Class D grounding (grounding resistance: 100 Ω or less) <Common grounding with a heavy electrical system is not allowed.>*3				
Working environment	Free from corrosive or flammable gas and excessive conductive dusts				
Working altitude	< 2000m*4				

*1. The criterion is shown in IEC61131-2.

*2. When this block is connected to the FX3UC Series PLC, the direct mounting method cannot be used.

*3.

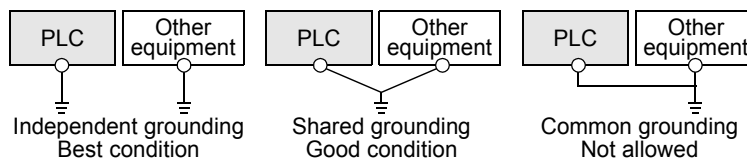

→ For a detailed description of grounding, refer to Section 3.5.

*4. If the pressure is higher than the atmospheric pressure, do not use the FX3U-4DA, as it may malfunction.

2.2 Power Supply Specifications

Item	Specifications
D/A conversion circuit drive power	24V DC $\pm 10\%$, 160mA (It is necessary to supply 24V DC from the terminal block.)
CPU drive power	5V DC, 120mA (Since the internal power is supplied from the main unit, it is not necessary to supply power externally.)

2.3 Performance Specifications

Item	Specifications	
	Voltage output	Current output
Analog output range	-10V to +10V DC (External load: 1k Ω to 1M Ω)	0mA to 20mA DC, 4mA to 20mA DC (External load: 500 Ω or less)
Offset ^{*1}	-10V to +9V ^{*2}	0mA to 17mA ^{*3}
Gain ^{*1}	-9V to +10V ^{*2}	3mA to 30mA ^{*3}
Digital input	With sign, 16bits, binary	15bits, binary
Resolution	0.32mV (20V / 64,000)	0.63 μ A (20mA / 32,000)
Overall accuracy ^{*4}	<ul style="list-style-type: none"> Ambient temperature: 25°C\pm5°C $\pm 0.3\%$ (± 60mV) for 20V full scale Ambient temperature: 0°C to 55°C $\pm 0.5\%$ (± 100mV) for 20V full scale 	<ul style="list-style-type: none"> Ambient temperature: 25°C\pm5°C $\pm 0.3\%$ ($\pm 60$$\mu$A) for 20mA full scale Ambient temperature: 0°C to 55°C $\pm 0.5\%$ ($\pm 100$$\mu$A) for 20mA full scale
Time required for D/A conversion	1ms (The number of selected channels will not affect this value.)	
Insulation method	<ul style="list-style-type: none"> The photocoupler is used to insulate the analog output area from the PLC. The DC/DC converter is used to insulate the analog output area from the power supply unit. Channels are not insulated from each other. 	
Number of I/O points occupied	8 points (Taken from either the input or output points of the PLC.)	

- *1. Adjustment of the offset or gain value will not affect the resolution. In output mode 1 or 4, however, the offset/gain cannot be adjusted.
- *2. The offset and the gain should satisfy the following condition:
 $1V \leq (\text{Gain} - \text{Offset}) \leq 10V$
- *3. The offset and the gain should satisfy the following condition:
 $3mA \leq (\text{Gain} - \text{Offset}) \leq 30mA$
- *4. When the external load is less than 30k Ω , please use the output corrective function by load resistance.
 → For a detailed description of the output corrective function by load resistance, refer to Subsection 5.4.17.

2.4 Output Mode (Characteristics) BFM #0

For the FX3U-4DA, there are two types of output characteristics: voltage (-10 to +10V) and current (0 to 20mA, 4 to 20mA) output characteristics. The output characteristics depend on the set output mode as described below.

1. Voltage output characteristics [-10 to +10V] (Output mode: 0, 1)

Set output mode: 0
 Output type: Voltage output
 Analog output range: -10 to +10V
 Digital input range: -32000 to +32000
 Offset/gain adjustment: Possible

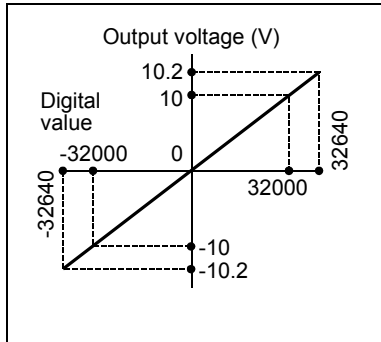

Set output mode: 1
 Output type: Voltage output
 (Specification of analog value mV)
 Analog output range: -10 to +10V
 Digital input range: -10000 to +10000
 Offset/gain adjustment: Impossible

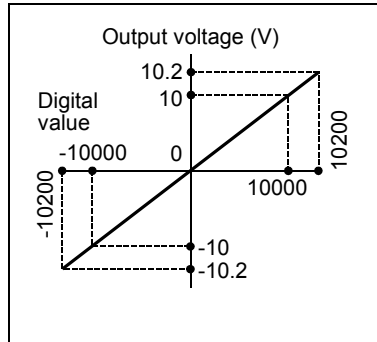

2. Current output characteristics [0 to 20mA] (Output mode: 2, 4)

Set output mode: 2
 Output type: Current output
 Analog output range: 0 to 20mA
 Digital input range: 0 to 32000
 Offset/gain adjustment: Possible

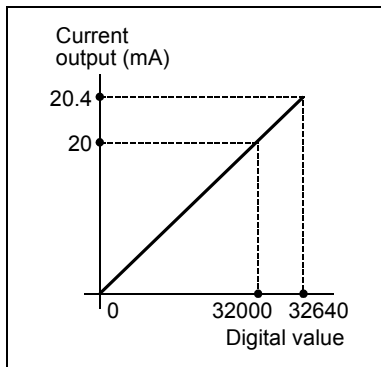

Set output mode: 4
 Output type: Current output
 (Specification of analog value μ A)
 Analog output range: 0 to 20 mA
 Digital input range: 0 to 20000
 Offset/gain adjustment: Impossible

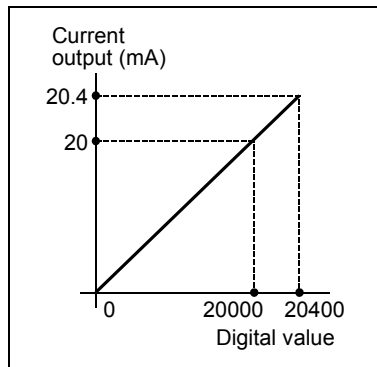

3. Current Output characteristics [4 to 20mA] (Output mode: 3)

Set output mode: 3
 Output type: Current output
 Analog output range: 4 to 20mA
 Digital input range: 0 to 32000
 Offset/gain adjustment: Possible

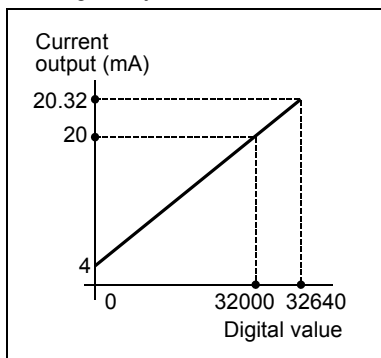

3. Wiring

This chapter describes wiring of the FX3U-4DA.
 Observe the following cautions wiring the FX3U-4DA.

WIRING PRECAUTIONS



- Make sure to cut off all phases of the power supply externally before attempting wiring work. Failure to do so may cause electric shock or damages to the product.

WIRING PRECAUTIONS



- Connect the DC power supply wiring to the dedicated terminals described in this manual. If an AC power supply is connected to a DC input/output terminal or DC power supply terminal, the PLC will be burnt out.
- Do not wire vacant terminals externally. Doing so may damage the product.
- Perform class D grounding (grounding resistance: 100Ω or less) to the grounding terminal on the main unit. Do not use common grounding with heavy electrical systems.
- When drilling screw holes or wiring, make sure cutting or wire debris does not enter the ventilation slits. Failure to do so may cause fire, equipment failures or malfunctions.
- Make sure to observe the following precautions in order to prevent malfunctions under the influence of noise:
 - Do not bundle the power line or twisted shielded cable together with or lay it close to the main circuit, high-voltage line, or load line. Otherwise, noise disturbance and/or surge induction are likely to take place. As a guideline, lay the control line at least 100mm (3.94") or more away from the main circuit, high-voltage line, or load line.
 - Ground the shield of the analog input/output cable at one point on the signal receiving side. However, do not use common grounding with heavy electrical systems.
- Make sure to properly wire the terminal block in accordance with the following precautions. Failure to do so may cause electric shock, equipment failures, a short-circuit, wire breakage, malfunctions, or damage to the product.
 - The disposal size of the cable end should follow the dimensions described in the manual.
 - Tightening torque should follow the specifications in the manual.

A
Common Items

B
FX3U-4AD
FX3UC-4AD

C
FX3U-4AD-ADP

D
FX3G-2AD-BD

E
FX3U-4DA

F
FX3U-4DA-ADP

G
FX3G-1DA-BD

H
FX3U-3A-ADP

I
FX3U-4AD-PT
-ADP

J
FX3U-4AD-PTW
-ADP

3.1 Terminal Layout

The terminals of FX3U-4DA are arranged as follows:

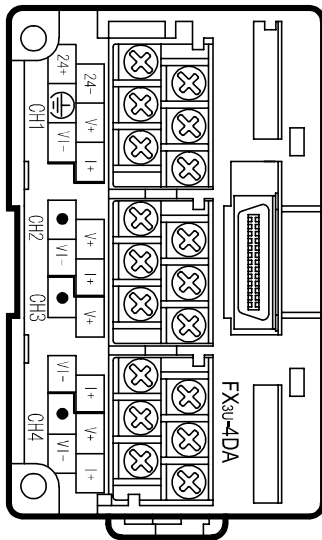

Signal	Application
24+	24V DC power supply
24-	
⊕	Ground terminal
V+	Channel-1 analog output
VI-	
I+	
•	Do not connect any lines.
V+	Channel-2 analog output
VI-	
I+	
•	Do not connect any lines.
V+	Channel-3 analog output
VI-	
I+	
•	Do not connect any lines.
V+	Channel-4 analog output
VI-	
I+	

3.2 Cable and Terminal Tightening Torque

The FX3U-4DA terminal block is designed for M3 screws.
 The end disposal of the cable shown below.
 Tighten the terminal to a torque of 0.5 to 0.8 N.m.
 Do not tighten terminal screws with a torque exceeding the regulation torque.
 Failure to do so may cause equipment failures or malfunctions.

- When one wire is connected to one terminal

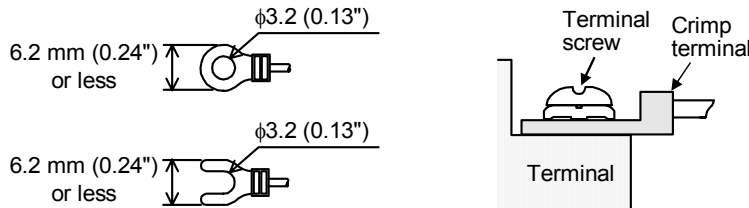

- When two wires are connected to one terminal

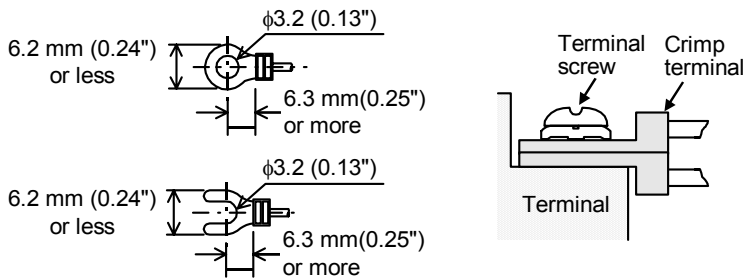

3.3 Wiring to Power Supply Terminals

3.3.1 Examples of Power Supply Circuit

Below are examples of circuits for using the 24V DC service power supply of the FX3G/FX3U Series PLC.

1) Sink input [- common] wiring

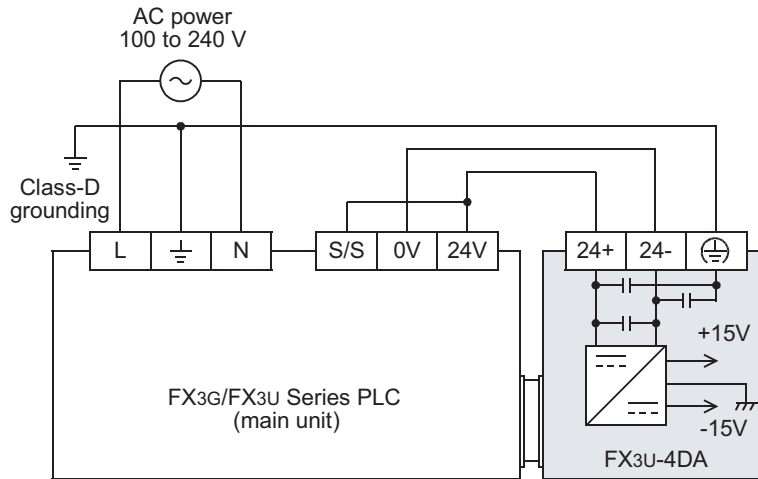

Connect the "S/S" terminal of the main unit to the "24V" terminal.

2) Source input [+ common] wiring

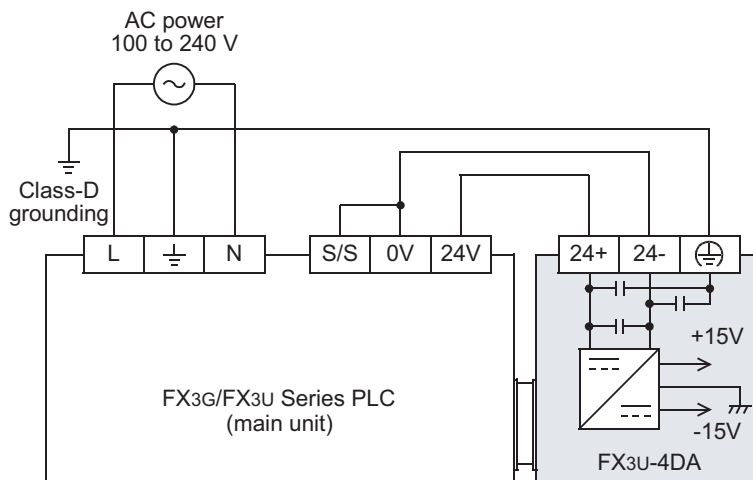

Connect the "S/S" terminal of the main unit to the "0V" terminal.

3.3.2 Cautions regarding wiring to the power supply terminals

- Ground the " \perp " terminal and " \oplus " terminal to the Class - D grounding line (100 Ω or less) together with the ground terminal of the main unit.
- For the timing of power-on/off when using an external power supply, see the following manual of the connected PLC.

→ Refer to the **FX3G Series User's Manual - Hardware Edition**.
 → Refer to the **FX3U Series User's Manual - Hardware Edition**.

3.4 Analog Output Wiring

The analog output mode, "voltage output" or "current output", can be selected for each channel.

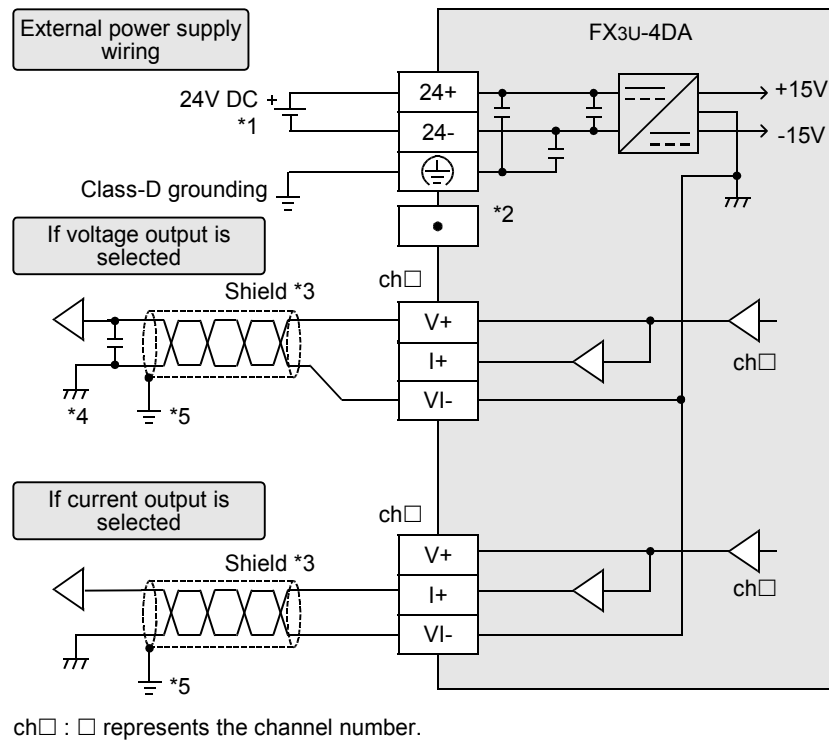

- *1. For FX3G/FX3U Series PLC (AC power type), the 24V DC service power supply is also available.
- *2. Do not connect any wires to the " • " terminal.
- *3. Use a 2-core twisted shield wire for analog output wire, and separate it from other power lines or inductive lines.
- *4. If there is ripple or noise in the output voltage, connect a capacitor of approximately 0.1 to 0.47 μ F 25V in the vicinity of the signal receiving side.
- *5. Ground the shielded wire at one point on the signal receiving side.

3.5 Grounding

Grounding should be performed as stated below.

- The grounding resistance should be 100 Ω or less.
- Independent grounding should be performed for best results.
 When independent grounding is not performed, perform "shared grounding" as shown in the following figure.

→ For details, refer to the User's Manual - Hardware Edition of each Series.

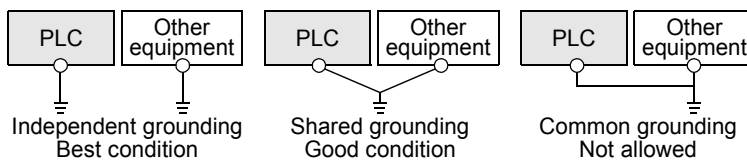

- The grounding wire size should be AWG14 (2mm².)
- The grounding point should be close to the PLC, and all grounding wires should be as short as possible.

4. Analog Output

This chapter describes the minimum programming necessary for analog output by the FX3U-4DA. Follow the procedure below to confirm that correct analog values can be output.

4.1 Analog Output Procedures

1 Unit number check

Unit numbers from 0 to 7 will be assigned to the special function units/blocks starting from the left. When the units/blocks are connected to the FX3UC-32MT-LT(-2) PLC, the unit numbers from 1 to 7 are assigned. Check the unit number assigned to the FX3U-4DA.

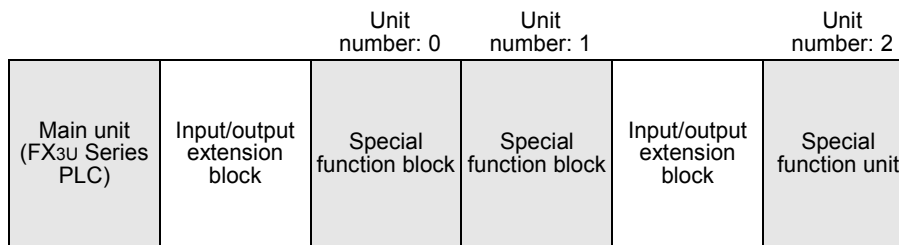

2 Output mode (BFM #0) setting

Depending on the analog signal generator to be connected, set the output mode (BFM #0) for each channel.

Use hexadecimal numbers for output mode setting. Set the corresponding channel digit to the output mode setting value specified in the following table:

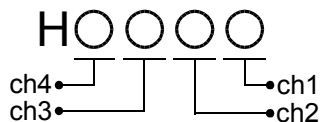

Setting value	Output mode	Analog output range	Digital input range
0	Voltage output mode	-10V to +10V	-32000 to +32000
1	Voltage output analog value mV specification mode	-10V to +10V	-10000 to +10000
2	Current output mode	0mA to 20mA	0 to 32000
3	Current output mode	4mA to 20mA	0 to 32000
4	Current output analog value μ A specification mode	0mA to 20mA	0 to 20000
F	Channel not used		

→ For a detailed description of the standard output characteristics, refer to Section 2.4.
 → For a detailed description of the output mode (BFM #0), refer to Subsection 5.4.1.

3 Creation of sequence program

Create the program as follows to output analog signals.

- While referring to step 2, set the output mode "H****".
- While referring to step 1, set the unit number in □
 - Program Example (For FX3U, FX3UC Series PLCs)*1

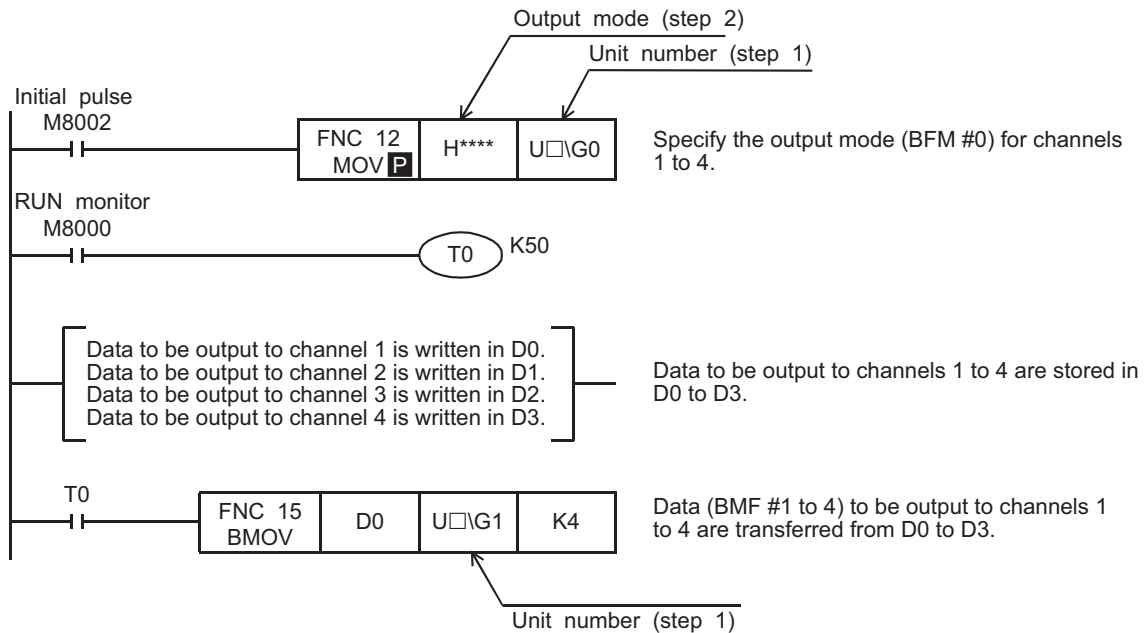

*1. Use the FROM and TO instructions in FX3G PLCs.

4 Transfer of sequence program and analog output signal check

- 1) Transfer the sequence program, and start the PLC.
- 2) Check that analog signals appropriate to the set output data are output.

→ If analog signals are not output correctly, refer to Chapter 9 "Troubleshooting."

5. Buffer Memory (BFM)

This chapter describes the buffer memory incorporated in FX3U-4DA.

5.1 Assignment of Unit Numbers and Outline of Buffer Memory

1. Assignment of unit numbers

Unit numbers from 0 to 7 will be assigned to the special function units/blocks starting from the left one. When the units/blocks are connected to the FX3UC-32MT-LT(-2) PLC, unit numbers from 1 to 7 are assigned.

When connected to the FX3G/FX3U/FX3UC (D, DS, DSS) Series PLC

		Unit number: 0	Unit number: 1		Unit number: 2
Main unit	Input/output extension block	Special function block	Special function block	Input/output extension block	Special function unit

When connected to the FX3UC-32MT-LT(-2) PLC

Unit number: 0 (Incorporated CC-Link/LT)		Unit number: 1	Unit number: 2		Unit number: 3
Main unit (FX3UC-32MT -LT(-2))	Input/output extension block	Special function block	Special function block	Input/output extension block	Special function unit

2. Outline of buffer memory

The digital values set in FX3U-4DA will be converted to analog signals.

To switch the output mode between voltage output and current output, or to adjust the offset or gain, numeric data will be sent from the main unit and written/set in the FX3U-4DA buffer memory.

To read/write data from/into the buffer memory of FX3U-4DA, the buffer memory can be directly specified using FROM/TO instructions or an applied instruction. Using this function, sequence programs can be easily created.

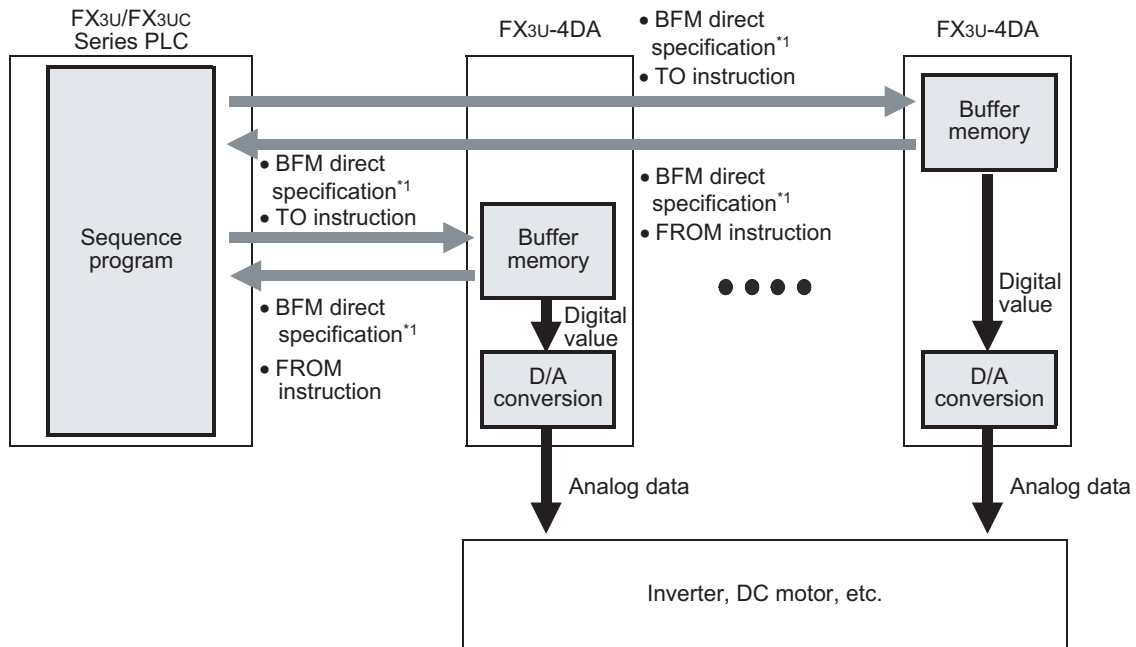

*1. Since buffer memory direct specification (U□\G□) can directly specify the buffer memory in the source or destination area of an applied instruction, programs can be created efficiently. (This function is supported only in FX3U/FX3UC PLCs.)

→ For a detailed description of buffer memory reading/writing, refer to Section 5.2.

→ For a detailed description of the buffer memory, refer to Section 5.4.

5.2 Buffer Memory Reading/Writing Method

To read or write the buffer memory of FX3U-4DA, use FROM/TO instructions or the buffer memory direct specification function*1.

To use the buffer memory direct specification function*1, however, it is necessary to adopt the software compatible with the FX3U/FX3UC Series PLC.

*1. This function is supported only in FX3U/FX3UC PLCs.

→ For a detailed description of the software compatible with the FX3U/FX3UC Series PLC, refer to Section 1.4.

5.2.1 Buffer memory direct specification (FX3U, FX3UC PLC only)

When directly specifying the buffer memory, specify the following device in the source or destination area of the applied instruction as follows:



1. Example 1

If the following program is created, data in buffer memory (BFM #10) of unit 1 will be multiplied by the data (K10), and then the multiplication result will be output to the data registers (D10, D11).

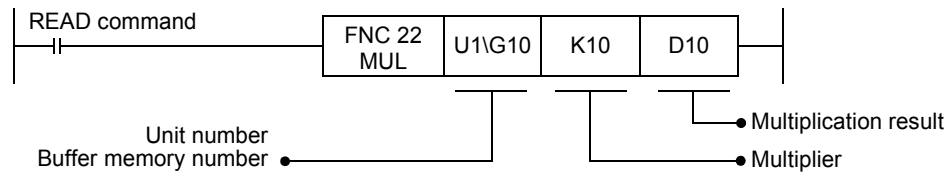

2. Example 2

If the following program is created, the value in the data register (D20) is added to K10 and written to buffer memory (BFM #6) of unit 1.

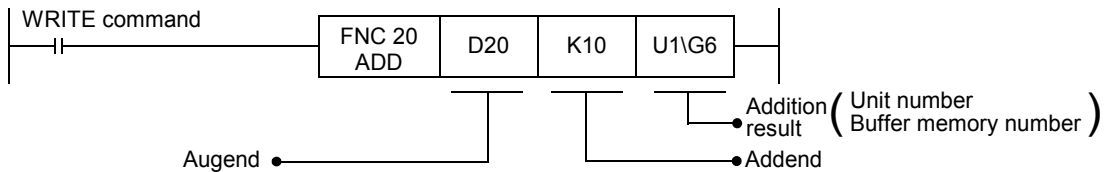

5.2.2 FROM/TO instruction (FX3G, FX3U, FX3UC PLC)

1. FROM instruction (Reading out BFM data to PLC)

Use FROM instruction to read out the data from the buffer memory. In a sequence program, use this instruction as follows:

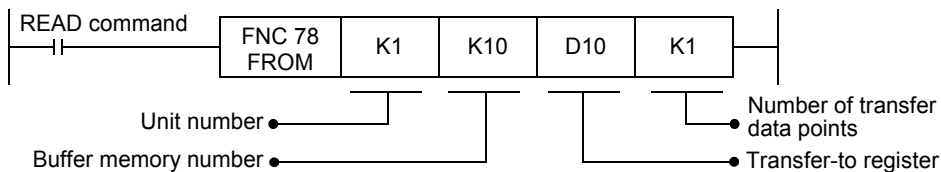

If the above program is created, 1 point of data will be read out from the buffer memory BFM #10 of unit No.1 to the data register (D10).

2. TO instruction (Writing PLC data into BFM)

Use the TO instruction to write data to a buffer memory. In a sequence program, use this instruction as follows:

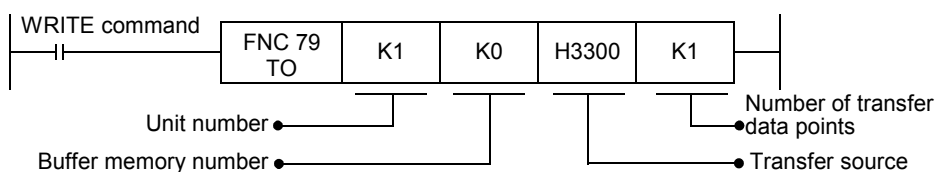

If the above program is created, 1 point of data (H3300) will be written to buffer memory (BFM #0) of unit No.1.

5.3 Buffer Memory List (BFM)

FX3U-4DA incorporates the following buffer memories.

→ For a detailed description of the buffer memory, refer to Section 5.4 and subsequent sections.

BFM number	Description	Setting range	Initial value	Data type	Reference
#0*1	Output mode setting for channels 1 to 4	*2	H0000 at delivery	Hexadecimal	Subsection 5.4.1
#1	Channel 1 output data	Depending on the mode used	K0	Decimal	Subsection 5.4.2
#2	Channel 2 output data		K0	Decimal	
#3	Channel 3 output data		K0	Decimal	
#4	Channel 4 output data		K0	Decimal	
#5*1	Output setting upon PLC stop	*3	H0000	Hexadecimal	Subsection 5.4.3
#6	Output status	-	H0000	Hexadecimal	Subsection 5.4.4
#7, #8	Not used	-	-	-	-
#9	Command to write offset/gain setting value of channels 1 to 4	*4	H0000	Hexadecimal	Subsection 5.4.5
#10*1	Channel-1 offset data (Unit: mV or μ A)	Depending on the mode used	Depending on the mode used	Decimal	Subsection 5.4.6
#11*1	Channel-2 offset data (Unit: mV or μ A)			Decimal	
#12*1	Channel-3 offset data (Unit: mV or μ A)			Decimal	
#13*1	Channel-4 offset data (Unit: mV or μ A)			Decimal	
#14*1	Channel-1 gain data (Unit: mV or μ A)	Depending on the mode used	Depending on the mode used	Decimal	Subsection 5.4.6
#15*1	Channel-2 gain data (Unit: mV or μ A)			Decimal	
#16*1	Channel-3 gain data (Unit: mV or μ A)			Decimal	
#17*1	Channel-4 gain data (Unit: mV or μ A)			Decimal	
#18	Not used	-	-	-	-
#19*1	Setting change prohibition	To permit data change: K3030 To disable data change: Value other than K3030	K3030 at delivery	Decimal	Subsection 5.4.7
#20	Initialization function: Set "K1" in this buffer memory to perform initialization. At the completion of initialization, the "K0" will be automatically set.	K0 or K1	K0	Decimal	Subsection 5.4.8
#21 to #27	Not used	-	-	-	-
#28	Disconnection detection status (Valid only in current mode selection)	-	H0000	Hexadecimal	Subsection 5.4.9
#29	Error status	-	H0000	Hexadecimal	Subsection 5.4.10
#30	Model code K3030	-	K3030	Decimal	Subsection 5.4.11
#31	Not used	-	-	-	-

- *1. If power failure occurs, the EEPROM will retain the data.
- *2. Specify the output mode of each channel setting one of hex code 0 to 4 and F in each digit.
- *3. Specify the data to be output from each channel upon PLC stop setting one of hex code 0 to 2 in each digit.
- *4. Use b0 to b3.

BFM number	Description	Setting range	Initial value	Data type	Reference
#32*1	Data to be output from channel 1 upon PLC stop (Valid only if BFM #5 = H0002)	Depending on the mode used	K0	Decimal	Subsection 5.4.12
#33*1	Data to be output from channel 2 upon PLC stop (Valid only if BFM #5 = H0020)	Depending on the mode used	K0	Decimal	
#34*1	Data to be output from channel 3 upon PLC stop (Valid only if BFM #5 = H0200)	Depending on the mode used	K0	Decimal	
#35*1	Data to be output from channel 4 upon PLC stop (Valid only if BFM #5 = H2000)	Depending on the mode used	K0	Decimal	
#36, #37	Not used	-	-	-	-
#38	Upper/lower limit function setting	*2	H0000	Hexadecimal	Subsection 5.4.13
#39	Upper/lower limit function status	-	H0000	Hexadecimal	Subsection 5.4.14
#40	Clear of upper/lower limit function status	*3	H0000	Hexadecimal	Subsection 5.4.15
#41	Channel-1 lower limit of upper/lower limit function	Depending on the mode used	K-32640	Decimal	Subsection 5.4.16
#42	Channel-2 lower limit of upper/lower limit function		K-32640	Decimal	
#43	Channel-3 lower limit of upper/lower limit function		K-32640	Decimal	
#44	Channel-4 lower limit of upper/lower limit function		K-32640	Decimal	
#45	Channel-1 upper limit of upper/lower limit function	Depending on the mode used	K32640	Decimal	Subsection 5.4.16
#46	Channel-2 upper limit of upper/lower limit function		K32640	Decimal	
#47	Channel-3 upper limit of upper/lower limit function		K32640	Decimal	
#48	Channel-4 upper limit of upper/lower limit function		K32640	Decimal	
#49	Not used	-	-	-	-
#50*1	Corrective function setting by load resistance (Valid only in voltage output mode)	*4	H0000	Hexadecimal	Subsection 5.4.17
#51*1	Load resistance value for channel 1 (Unit: Ω)	K1000 to K30000	K30000	Decimal	Subsection 5.4.17
#52*1	Load resistance value for channel 2 (Unit: Ω)	K1000 to K30000	K30000	Decimal	
#53*1	Load resistance value for channel 3 (Unit: Ω)	K1000 to K30000	K30000	Decimal	
#54*1	Load resistance value for channel 4 (Unit: Ω)	K1000 to K30000	K30000	Decimal	
#55 to #59	Not used	-	-	-	-
#60*1	Status automatic transfer function setting	*5	K0	Decimal	Subsection 5.4.18
#61*1	Error status data (BFM #29) automatic transfer-to data register specification (Valid if b0 of BFM #60 is set to ON)	K0 to 7999 (BFM #61, #62 and #63 must have different values.)	K200	Decimal	Subsection 5.4.19
#62*1	Upper/lower limit function status data (BFM #39) automatic transfer-to data register specification (Valid if b1 of BFM #60 is set to ON)		K201	Decimal	Subsection 5.4.20
#63*1	Disconnection detection status data (BFM #28) automatic transfer-to data register specification (Valid if b2 of BFM #60 is set to ON)		K202	Decimal	Subsection 5.4.21
#64 to #79	Not used	-	-	-	-

- *1. If power failure occurs, the EEPROM will retain the data.
- *2. Specify the use of the upper/lower limit function for each channel setting one of hex code 0 to 2 in each digit.
- *3. Use b0 to b1.
- *4. Specify the use of the corrective function by load resistance for each channel setting a hex code 0 or 1 in each digit.
- *5. Use b0 to b2.

A Common Items
B FX3U-4AD, FX3UC-4AD
C FX3U-4AD-ADP
D FX3G-2AD-BD
E FX3U-4DA
F FX3U-4DA-ADP
G FX3G-1DA-BD
H FX3U-3A-ADP
I FX3U-4AD-PT-ADP
J FX3U-4AD-PTW-ADP

BFM number	Description	Setting range	Initial value	Data type	Reference
#80	Start/stop of table output function	*1	H0000	Hexadecimal	Chapter 6
#81	Channel-1 output pattern	K1 to K10	K1	Decimal	
#82	Channel-2 output pattern	K1 to K10	K1	Decimal	
#83	Channel-3 output pattern	K1 to K10	K1	Decimal	
#84	Channel-4 output pattern	K1 to K10	K1	Decimal	
#85	Number of times of output execution of table from channel 1	K0 to K32767	K0	Decimal	
#86	Number of times of output execution of table from channel 2	K0 to K32767	K0	Decimal	
#87	Number of times of output execution of table from channel 3	K0 to K32767	K0	Decimal	
#88	Number of times of output execution of table from channel 4	K0 to K32767	K0	Decimal	
#89	Output completion flag of table output function	-	H0000	Hexadecimal	
#90	Table output error code	-	K0	Decimal	
#91	Table output error occurrence number	-	K0	Decimal	
#92 to #97	Not used	-	-	-	-
#98	Head device number in data table	K0 to K32767	K1000	Decimal	Chapter 6
#99	Data table transfer command	*2	H0000	Hexadecimal	
#100 to #398	Data table in pattern 1	-	K0	Decimal	-
#399	Not used	-	-	-	-
#400 to #698	Data table in pattern 2	-	K0	Decimal	Chapter 6
#699	Not used	-	-	-	-
#700 to #998	Data table in pattern 3	-	K0	Decimal	Chapter 6
#999	Not used	-	-	-	-
#1000 to #1298	Data table in pattern 4	-	K0	Decimal	Chapter 6
#1299	Not used	-	-	-	-
#1300 to #1598	Data table in pattern 5	-	K0	Decimal	Chapter 6
#1599	Not used	-	-	-	-
#1600 to #1898	Data table in pattern 6	-	K0	Decimal	Chapter 6
#1899	Not used	-	-	-	-
#1900 to #2198	Data table in pattern 7	-	K0	Decimal	Chapter 6
#2199	Not used	-	-	-	-
#2200 to #2498	Data table in pattern 8	-	K0	Decimal	Chapter 6
#2499	Not used	-	-	-	-
#2500 to #2798	Data table in pattern 9	-	K0	Decimal	Chapter 6
#2799	Not used	-	-	-	-
#2800 to #3098	Data table in pattern 10	-	K0	Decimal	Chapter 6

*1. Specify whether to start or stop the table output function for each channel setting a hex code 0 or 1 in each digit.

*2. Specify the data table transfer command and the register type setting 0 or 1 in the last two digits of the hex code.

5.4 Buffer Memory Details

5.4.1 BFM #0: Output mode specification

Initial value (at delivery): H0000
 Numeric data type: Hexadecimal (H)

Specify the output modes of channel 1 to 4.
 4 hexadecimal digits are assigned to specify the output modes of the 4 channels.
 Change the value of each digit to change the output mode of each channel. 0 to 4 and F can be set for each digit.

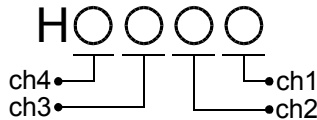

The different types of output modes are shown in the following table:
 → For a detailed description of output characteristics, refer to Section 2.4.

Set value [HEX]	Output mode	Analog output range	Digital input range
0	Voltage output mode	-10V to +10V	-32000 to +32000
1*1	Voltage output analog value mV specification mode	-10V to +10V	-10000 to +10000
2	Current output mode	0mA to 20mA	0 to 32000
3	Current output mode	4mA to 20mA	0 to 32000
4*1	Current output analog value μ A specification mode	0mA to 20mA	0 to 20000
5 to E	Invalid (setting values unchanged)	-	-
F	Channel not used		

*1. The offset/gain values cannot be changed.

1. Cautions regarding output mode setting

- While the output mode is being changed, the output is stopped, and H0000 is automatically written in the output status (BFM #6).
 At the completion of change of the output mode, the output status (BFM #6) will automatically change to H1111, and the output is restarted.
 - It takes approximately 5 seconds to determine the output mode.
 For this reason, after changing the output mode, be sure to wait for 5 seconds or more, and then write the other data.
 - When the output mode is changed, the settings in the following buffer memory are initialized according to the new output mode.
 - BFM #5 (output setting upon PLC stop)*1
 - BFM #10 to #13 (offset data)*2
 - BFM #14 to #17 (gain data)*2
 - BFM #28 (disconnection detection status)*3
 - BFM #32 to #35 (output data upon PLC stop)*2
 - BFM #38 (upper/lower limit function setting)*1
 - BFM #41 to #44 (lower limit values of upper/lower limit function)*2
 - BFM #45 to #48 (upper limit values of upper/lower limit function)*2
 - BFM #50 (Setting of output corrective function by load resistance)*1
- *1 FX3U-4DA initializes the corresponding bit to the channel where the user has changed the output mode.
 *2 FX3U-4DA initializes the corresponding buffer memory to the channel where the user has changed the output mode.
 *3 These settings are initialized only when the output mode is changed from current output mode (mode 2, 3 or 4) to voltage output mode (mode 0 or 1).
- HFFFF (use of no channels) cannot be set.

2. Caution regarding EEPROM writing

If data is written to BFM #0, #5, #10 to #17, #19, #32 to #35, #50 to #54 or #60 to #63, the data will also be written to the FX3U-4DA EEPROM.

Do not turn off the power immediately after writing values in these buffer memories.

The maximum number of EEPROM rewrites is 10,000 times. Therefore, when creating a program, do not frequently write data to the above buffer memories (BFM).

5.4.2 BFM #1 to #4: Output data

Initial value: K0
Numeric data type: Decimal (K)

Input the digital values corresponding to the analog signals to be output in BFM #1 to #4.

BFM number	Description
#1	Data to be output from channel 1
#2	Data to be output from channel 2
#3	Data to be output from channel 3
#4	Data to be output from channel 4

5.4.3 BFM #5: Output setting upon PLC stop

Initial value: H0000
Numeric data type: Hexadecimal (H)

It is possible to set the output conditions from channel 1 to 4 when the PLC is in the stopped state.

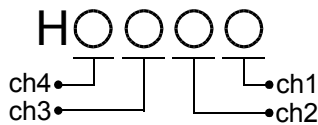

Set value (HEX)	Output conditions
0	The final value during running is held.
1	The offset signal is output.*
2	The output data set in BFM #32 to #35 are output.*
3 to F	Invalid (setting values unchanged)

* The output conditions depend on the output mode (BFM #0).

1. Cautions regarding output conditions setting upon PLC stop

- While changing the setting values, the output is stopped, and H0000 is automatically written in the output status (BFM #6).
 At the completion of change, the output status (BFM #6) will automatically change to H1111, and output will be restarted.

2. Caution regarding EEPROM writing

- If data is set in BFM #0, #5, #10 to #17, #19, #32 to #35, #50 to #54 or #60 to #63, the data will be written in the EEPROM of FX3U-4DA.

Do not turn off the power immediately after writing values in these buffer memories.

The maximum number of EEPROM rewritable times is 10,000 times. Therefore, when creating a program, do not frequently write data to the above buffer memories (BFM).

5.4.4 BFM #6: Output status

Initial value: H0000
 Numeric data type: Hexadecimal (H)

The output status information of channel 1 to 4 is stored.

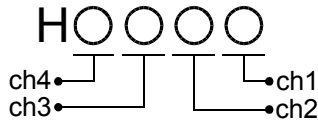

Value status (HEX)	Description
0	Output updating is stopped.*
1	Under output updating

* The output conditions conform to the output setting upon PLC stop (BFM #5).

1. Cautions regarding use of output status

- The output status setting is valid only if the PLC is running. When the PLC is stopped, H0000 is automatically written.
- When the setting in any of the following buffer memory areas is changed, output updating is stopped. H0000 is automatically written in BFM #6.
 - BFM #0 (Output mode setting)
 - BFM #5 (Output setting upon PLC stop)
 - BFM #9 (Offset/gain setting value write command)
 - BFM #19 (Setting change prohibition)
 - BFM #20 (Initialization function)
 - BFM #32 to #35 (Data to be output from each channel upon PLC stop)
 - BFM #50 (Corrective function setting by load resistance)
 - BFM #51 to #54 (Load resistance for each channel)
 - BFM #60 (Status automatic transfer function Setting)
 - BFM #61 (Error status data automatic transfer-to data register specification)
 - BFM #62 (Upper/lower limit function status with automatic transfer to specified data register)
 - BFM #63 (Disconnection detection status with automatic transfer to data register specification)
 - BFM #99 (Data table transfer command)

A	Common Items
B	FX3U-4AD FX3UC-4AD
C	FX3U-4AD-ADP
D	FX3G-2AD-BD
E	FX3U-4DA
F	FX3U-4DA-ADP
G	FX3G-1DA-BD
H	FX3U-3A-ADP
I	FX3U-4AD-PT-ADP
J	FX3U-4AD-PTW-ADP

5.4.5 BFM #9: Offset/gain setting value write command

Initial value: H0000
Numeric data type: Hexadecimal (H)

Channel numbers are assigned to 4 lower bits of BFM #9. If one of those bits is turned on, the offset data (BFM #10 to #13) and the gain data (BFM #14 to #17) of the corresponding channel will be written in the internal memory (EEPROM). When written in the internal memory, the data will be valid.

1. Channel number assignment to each bit of BFM #9

Bit No.	Description
b0	Channel-1 offset data (BFM #10) and gain data (BFM #14) writing
b1	Channel-2 offset data (BFM #11) and gain data (BFM #15) writing
b2	Channel-3 offset data (BFM #12) and gain data (BFM #16) writing
b3	Channel-4 offset data (BFM #13) and gain data (BFM #17) writing
b4 to b15	Not used

The WRITE command can be given to two or more channels at the same time. (Set "H000F" to write the data of all the channels in the EEPROM.)

On completion of writing, "H0000" (b0 to b3: OFF) will be set automatically.

2. Cautions regarding giving offset/gain setting value write command

- While changing the setting, the output is stopped, and H0000 is automatically written in the output status (BFM #6).
 At the completion of writing, the output status (BFM #6) will automatically change to H1111, and output will be restarted.
- If the analog value specification mode (mode 1 or 4) is used, the offset/gain cannot be changed.
 When other output mode has been set, it is possible to change to same characteristics as those in the output mode 1 or 4.
- If the write command is not executed, the offset and gain data will not be stored in the EEPROM.
- When b1 of the error status (BFM #29) is set to ON, the offset and gain data will not be stored in the EEPROM.

→ For a detailed description of offset and gain setting, refer to Subsection 5.4.6.

5.4.6 BFM #10 to #13: Offset data/BFM #14 to #17: Gain data

Setting range: See below
Initial value: See below
Numeric data type: Decimal (K)

If the output mode is specified in BFM #0, the initial value of the offset data and gain data of each channel will be automatically stored.

The initial offset data and the gain data are set for each mode as shown in the following table:

- Offset data: Analog output value when the output data in BFM #1 to #4 are 0 (reference offset value)
- Gain data: Analog output value when the output data in BFM #1 to #4 are the reference gain values (The reference gain value depends on the set output mode.)

1. Reference offset/gain value and initial value set

Output mode (BFM #0)		Offset (channels 1 to 4: BFM #10 to #13)		Gain (channels 1 to 4: BFM #14 to #17)	
Set value	Description	Reference value	Initial value	Reference value	Initial value
0	Voltage output (-10 V to +10 V: -32000 to +32000)	0	0mV	16000	5000mV
1	Voltage output Analog value mV specification mode (-10 V to +10 V: -10000 to +10000)	0 (Data change impossible)	0mV (Data change impossible)	5000 (Data change impossible)	5000mV (Data change impossible)
2	Current output (0 mA to 20 mA: 0 to 32000)	0	0 μ A	16000	10000 μ A
3	Current output (4 mA to 20 mA: 0 to 32000)	0	4000 μ A	16000	12000 μ A
4	Current output Analog value μ A specification mode (0 mA to 20 mA: 0 to 20000)	0 (Data change impossible)	0 μ A (Data change impossible)	10000 (Data change impossible)	10000 μ A (Data change impossible)

2. Offset/gain data change

Set offset data and gain data to change the output characteristics.

The offset and gain data can be set for each channel. If the voltage output mode is set, write the offset and gain data in mV. If the current output mode is set, write the offset and gain data in μ A.

To change the offset or gain data, execute the offset/gain setting value write command (BFM #9).

The setting range is shown in the following table.

	Voltage output (mV)	Current output (μ A)
Offset data	-10000 to +9000 ^{*1}	0 to 17000 ^{*2}
Gain data	-9000 to +10000 ^{*1}	3000 to 30000 ^{*2}

*1. The offset and gain values should meet the following conditions:
 $1000 \leq \text{Gain value} - \text{Offset value} \leq 10000$

*2. The offset and gain values should meet the following conditions:
 $3000 \leq \text{Gain value} - \text{Offset value} \leq 30000$

3. Cautions regarding offset/gain data change

- If the analog value specification mode (mode 1 or 4) is used, the offset/gain cannot be changed. However, the characteristics can be changed as those in the output mode 1 or 4 by setting the following offset and gain data in the output mode 0 or 2.

	Offset data	Gain data
Change characteristics from output mode 0 to 1	0	16000
Change characteristics from output mode 2 to 4	0	16000

- The offset and gain data should be set before the value write command BFM #9 is executed.
- The resolution cannot be increased by changing the output characteristics.
- When the value specified as the output mode (BFM #0) is changed, the initial value of offset and gain data in each output mode will be automatically written.
- Even if the output characteristics are changed, the actual valid output range will not be changed: -10 V to +10 V for the voltage output mode, and 0 mA to 20 mA in the current output mode.
 → For a detailed description of output characteristics change, refer to Chapter 7.

5.4.7 BFM #19: Data change prohibition of setting change

Setting range: K3030 or other than K3030
 Initial value: K3030
 Numeric data type: Decimal (K)

Setting in the following buffer memory areas is prohibited.

- BFM #0 (output mode setting Output mode setting)
- BFM #5 (output setting upon PLC stop)
- BFM #9 (offset/gain setting value write command)
- BFM #10 to #13 (offset data)
- BFM #14 to #17 (gain data)
- BFM #20 (initialization function)
- BFM #32 to #35 (data to be output upon PLC stop)
- BFM #38 (upper/lower limit function setting)
- BFM #41 to #48 (upper and lower limit values of upper/lower limit function)
- BFM #50 (corrective function setting by load resistance)
- BFM #51 to #54 (load resistance values)
- BFM #60 (status automatic transfer function setting)
- BFM #61 (Error status data automatic transfer-to data register specification)
- BFM #62 (Upper/lower limit function status with automatic transfer to specified register specification)
- BFM #63 (Disconnection detection status with automatic transfer to specified data register specification)

Specify the following value as the setting change prohibition mode (BFM #19).

Set value	Description
K3030	permits data change
Other than K3030	disables data change

1. Cautions regarding setting of the setting change prohibition mode

- While changing the setting value, the output is stopped, and H0000 is automatically written in the output status (BFM #6).
 At the completion of writing, the output status (BFM #6) will automatically change to H1111, and the output will be restarted.

2. Cautions regarding EEPROM writing

If data is set in BFM #0, #5, #10 to #17, #19, #32 to #35, #50 to #54 or #60 to #63, the data will be written in the EEPROM of FX3U-4DA.

Do not turn off power immediately after writing values in these buffer memories

The maximum number of EEPROM rewritable times is 10,000. Therefore, when creating a program, do not frequently write data in the above buffer memories (BFM).

5.4.8 BFM #20: Initialization function (resetting to factory default status)

Setting range: K0 or K1
Initial value: K0
Numeric data type: Decimal (K)

When K1 is set in BFM #20, all functions and all buffer memory (BFM #0 to #3098) will be initialized to the default status.

When BFM #20 is not K0 or K1, this function is invalid. (The settings will not be changed, and the functions will not be initialized.)

1. Cautions regarding initialization function

- During initialization, output is stopped, and H0000 is automatically written in the output status (BFM #6). At the completion of initialization, the output status (BFM #6) will automatically change to H1111, and output will be restarted.
- It takes approximately 5 seconds to initialize all the data. Do not set (write) data in the buffer memory during this period.
- Priority is given to the setting of the value change prohibition mode (BFM #19).
- At the completion of initialization, the value of BFM #20 will automatically change to K0.

5.4.9 BFM #28: Disconnection detection status (only in current output mode)

Initial value: H0000
Numeric data type: Hexadecimal (H)

When a wire-break is detected, the bit corresponding to the relevant channel will turn on.

1. Assignment to each bit of BFM #28

Bit No.	Description
b0	Wire-break in channel 1
b1	Wire-break in channel 2
b2	Wire-break in channel 3
b3	Wire-break in channel 4
b4 to b15	Not used

2. Cautions regarding use of disconnection detection status

- When any of b0 to b3 is turned on, b11 of the error status (BFM #29) is turned on.
- The disconnection detection status is valid only if the output mode (BFM #0) is the current output mode (mode 2 to 4). In other output modes, each corresponding bit of BFM #28 stays off.

3. Disconnection detection status automatic transfer function (b2 of BFM #60)

If the disconnection detection status with automatic transfer-to data register is specified in BFM #63, the data in BFM #28 can be transferred to the specified data register.

Only when wire-break is detected, data will be automatically transferred from FX3U-4DA to the PLC. For this reason, the PLC does not need the program for reading data, and the scan time of the PLC can be shortened.

→ For a detailed description of the status automatic transfer function, refer to Subsection 5.4.18.



5.4.10 BFM #29: Error status

Initial value: H0000
Numeric data type: Hexadecimal (H)

Error data is assigned each bit of BFM #29.

1. Assignment to each bit of BFM #29

Bit No.	Item	Description
b0	Error detection	If one of b1 to b11 is turned on, b0 will turn on.
b1	O/G error	Gain setting error: error in offset gain data or in EEPROM offset gain setting
b2	Power supply error	24 V power is not supplied properly. Check the wiring condition or the supplied voltage.
b3	Hardware error	FX3U-4DA may be defective. Please contact the nearest Mitsubishi Electric distributor office.
b4	-	-
b5	Error setting function for output setting upon PLC stop	The setting value of the function for output setting upon PLC stop (BFM #5) is not set correctly. Correctly set the value.
b6	Upper/lower limit function setting error	The setting value of the upper/lower limit function (BFM #41 to BFM #48) is not set correctly. Correctly reset the value.
b7	Error in corrective function setting by load resistance (Valid only in voltage output mode)	The setting value of the corrective function by load resistance (BFM #51 to #54) is not set correctly. Correctly set the value.
b8	Table output function setting error	The setting value of the table output function is not set correctly. Correctly set the value.
b9	Status automatic transfer setting error	The setting value of the status automatic transfer function (BFM #61 to #63) is not set correctly. Correctly set the value.
b10	Over-scale	The analog output is out of the specified range.
b11	Disconnection detection (Valid only in current output mode)	Wire-break has occurred. (The details are indicated by BFM #28.) * The bit is turned on when BFM #28 is not 0.)
b12	Setting data change prohibited	Setting change is prohibited.
b13 to b15	-	-

2. Caution regarding error status

If the error cause is eliminated, the error bit will turn off.

3. Error status data automatic transfer function (b0 of BFM #60)

If the error status with automatic transfer to data register is specified in BFM #61, the data in BFM #29 can be transferred to a specified data register.

Only when an error is detected, data will be automatically transferred from FX3U-4DA to the PLC. For this reason, the PLC does not need the program for reading data, and the scan time of the PLC can be shortened.

→ For a detailed description of the status automatic transfer function, refer to Subsection 5.4.18.

5.4.11 BFM #30: Model code

Initial value (at delivery): K3030
Numeric data type: Decimal (K)

K3030 (fixed value) is stored as the model code.

5.4.12 BFM #32 to #35: Data to be output upon PLC stop

Initial value: K0
Numeric data type: Decimal (K)

To enable the output data set when the PLC stops, Set "2" for any digit in the output data (H0000) at PLC's stop. Set the BFM values as follows.

BFM number	Description
#32	Data in channel 1
#33	Data in channel 2
#34	Data in channel 3
#35	Data in channel 4

The setting range depends on the output mode.

Output mode [BFM #0]	Setting range
0	-32640 to +32640
1	-10200 to +10200
2, 3	0 to 32640
4	0 to 20400

1. Cautions regarding data output setting when PLC is in stop

- While changing the settings, the output is stopped, and H0000 is automatically written in the output status (BFM #6).
 After the completion of writing, the output status (BFM #6) will automatically change to H1111, and output will be restarted.
- The analog values to be output depend on the output mode.
- When a value out of any of the above ranges is set, b5 of the error status (BFM #29) is turned on.

2. Cautions regarding EEPROM writing

If data is set in BFM #0, #5, #10 to #17, #32 to #35, #50 to #54 or #60 to #63, the data will be written in the EEPROM of FX3U-4DA.

Do not turn off the power immediately after writing values in these buffer memories.

The maximum number of EEPROM rewritable times is 10,000. Therefore, when creating a program, do not frequently write data in the above buffer memories (BFM).

5.4.13 BFM #38: Upper/lower limit function setting

Initial value: H0000
Numeric data type: Hexadecimal (H)

When any of the output data (BFM #1 to #4) becomes less than the lower limit (BFM #41 to #44) or more than the upper limit (BFM #45 to #48), the relevant bit of the upper/lower limit function status (BFM #39) is turned on.

The upper/lower limit function can be set valid or made invalid by writing a 4-digit hexadecimal number, H0000, in BFM #38.

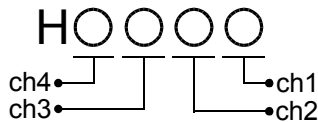

Set value	Description
0	The upper/lower limit function is invalid.
1	The upper/lower limit function without output limitation is valid.*1
2	The upper/lower limit function with output limitation is valid.*2
Other than above values	Invalid (setting values unchanged)

- *1. When any value becomes less than the lower limit (BFM #41 to #44) or more than the upper limit (BFM #45 to #48), the relevant bit of the upper/lower limit function status is turned on.

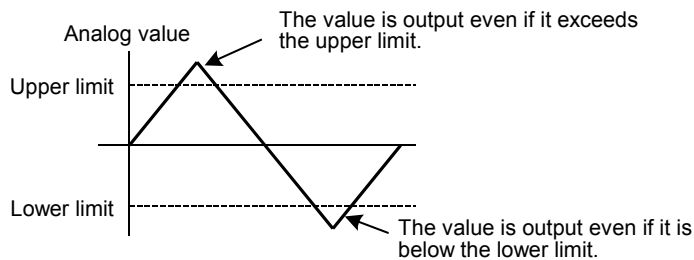

- *2. When any value becomes less than the lower limit (BFM #41 to #44) or more than the upper limit (BFM #45 to #48), the relevant bit of the upper/lower limit function status is turned on. In this setting, analog values more than the upper limit and less than the lower limit are not output.

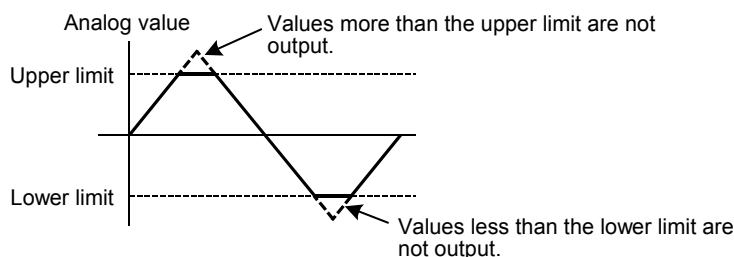

5.4.14 BFM #39: Upper/lower limit function status

Initial value: H0000
 Numeric data type: Hexadecimal (H)

When any of the output data (BFM #1 to #4) is out of range between the lower limit and the upper limit (BFM #41 to #48), the relevant bit is turned on.

1. Assignment to each bit of BFM #39

Bit	Description
b0	Data output from channel 1 < Lower limit (BFM #41)
b1	Data output from channel 1 > Upper limit (BFM #45)
b2	Data output from channel 2 < Lower limit (BFM #42)
b3	Data output from channel 2 > Upper limit (BFM #46)
b4	Data output from channel 3 < Lower limit (BFM #43)
b5	Data output from channel 3 > Upper limit (BFM #47)
b6	Data output from channel 4 < Lower limit (BFM #44)
b7	Data output from channel 4 > Upper limit (BFM #48)
b8 to b15	Not used

2. Cautions regarding use of the upper/lower limit function status

- The ON bits of the upper/lower limit function status are latched after the output data has returned to the specified ranges between the upper and lower limits.
- The upper/lower limit function status can be reset by the following methods.
 - Use the upper/lower limit function status reset function (BFM #40).
 - Turn the power supply off then on.

3. Upper/lower limit automatic transfer function (b1 of BFM #60)

If the upper/lower limit automatic transfer data register is specified in BFM #62, the data in BFM #39 can be transferred to a specified data register.

Only when an error is detected, data will be automatically transferred from the FX3U-4DA to the PLC. For this reason, the PLC does not need the program for reading data, and the scan time of the PLC can be shortened.

→ For a detailed description of the status automatic transfer function, refer to Subsection 5.4.18.

5.4.15 BFM #40: Clearance of upper/lower limit function status

Initial value: H0000
 Numeric data type: Hexadecimal (H)

The flags can be reset by turning on the following bits of BFM #40.

1. Assignment to each bit of BFM #40

Bit	Description
b0	Clearance of lower limit status
b1	Clearance of upper limit status
b2 to b15	Invalid

2. Operation to be performed after resetting

At the completion of status reset, the bits of BFM #40 will automatically turn off.

A Common Items
 B FX3U-4AD, FX3UC-4AD
 C FX3U-4AD-ADP
 D FX3G-2AD-BD
 E FX3U-4DA
 F FX3U-4DA-ADP
 G FX3G-1DA-BD
 H FX3U-3A-ADP
 I FX3U-4AD-PT-ADP
 J FX3U-4AD-PTW-ADP

**5.4.16 BFM #41 to #44: Lower limit values of upper/lower limit function
 BFM #45 to #48: Upper limit values of upper/lower limit function**

Initial value: See below
Numeric data type: Decimal (K)

When the upper/lower limit function has been made valid by the setting of BFM #38, set the upper and lower limit values to be used.

The setting range depends on the output mode.

1. Setting range of upper and lower limits and initial values

Output mode [BFM #0]	Setting range	Initial value	
		Lower limit value [BFM #41 to #44]	Upper limit value [BFM #45 to 48]
0	-32640 to +32640	-32640	+32640
1	-10200 to +10200	-10200	+10200
2, 3	0 to +32640	0	+32640
4	0 to +20400	0	+20400

2. Cautions regarding upper and lower limit values setting

Check that the lower limit value is not equal to or more than the upper limit value.

If the lower limit value is equal to or more than the upper limit value, b6 of the error status (BFM #29) is turned on.

5.4.17 BFM #50: Setting of output corrective function by load resistance (only in voltage output mode)/BFM #51 to #54: Load resistance values

Initial value: BFM #50: H0000, BFM #51 to #54: K30000
 Numeric data type: BFM #50: Hexadecimal (H), BFM #51 to #54: Decimal (K)

The output characteristics of FX3U-4DA have been adjusted at 30 kΩ load resistance as a factory default. When the load resistance is 1kΩ, the output deviation is approx. -4.3% to 20V in full scale, whereas the output deviation is approx. 0.15% to 20V in full scale when the load resistance is 1MΩ. When the load resistance is 30 kΩ or less (1 kΩ to 30 kΩ), the deviation of the output characteristics can be corrected by specifying the output corrective function (BFM #50) and the load resistance values (BFM #51 to #54).

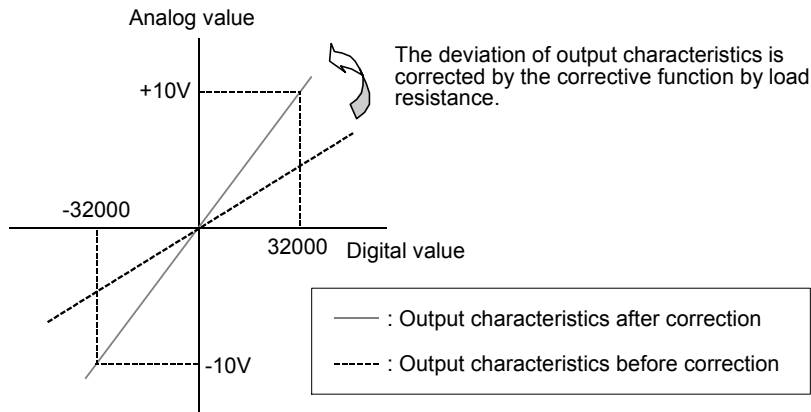

1. Setting of output corrective function (BFM #50)

The corrective function by load resistance is valid or invalid by writing a 4-digit hexadecimal number, H0000, in the output corrective function setting (BFM #50).

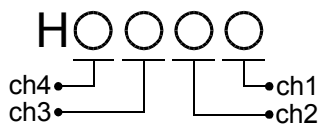

Set value	Description
0	Corrective function by load resistance is invalid.
1	Corrective function by load resistance is valid.
Other than above values	Invalid (setting values unchanged)

2. Setting range and initial value of load resistance (BFM #51 to #54)

Set the load resistance value for each channel allocated to the following BFM.

BFM number	Description	Setting range (Ω)	Initial value (Ω)
#51	Load resistance value for channel 1	1000 to 30000	30000
#52	Load resistance value for channel 2		
#53	Load resistance value for channel 3		
#54	Load resistance value for channel 4		

3. Cautions regarding use of the output corrective function by load resistance

- While changing the settings, the output is stopped, and H0000 is automatically written in the output status (BFM #6).
 At the completion of writing, the output status (BFM #6) will automatically change to H1111, and the output will be restarted.
- This function is valid only in the voltage output mode (mode 0 or 1).
- The corrective function by load resistance is valid only at a load resistance from 1 k to 30 kΩ.
- If a setting is out of the upper setting range, b7 of the error status BFM #29 is turned on.
- When not using this function, the output characteristics at a load resistance of 30 kΩ are applied.

4. Cautions regarding EEPROM writing

If data is set in BFM #0, #5, #10 to #17, #19, #32 to #35, #50 to #54 or #60 to #63, the data will be written in the EEPROM of FX3U-4DA.

Do not turn off the power immediately after writing values in these buffer memories.

The maximum number of EEPROM rewritable times is 10,000. Therefore, when creating a program, do not frequently write data in the above buffer memories (BFM).

5.4.18 BFM #60: Status automatic transfer function setting

Initial value: H0000

Numeric data type: Hexadecimal (H)

When the bits, b0 to b2, of BFM #60 are turned on, the assigned functions (see the table below) are valid. When the bits are turned off, the functions are invalid.

1. Assignment to each bit of BFM #60

Bit No.	Description	Reference
b0	When the value of the error status (BFM #29) changes, the status value is transferred to the data register specified by BFM #61.	Subsection 5.4.10 Subsection 5.4.19
b1	When the value of the upper/lower limit function status (BFM #39) changes, the status value is transferred to the data register specified by BFM #62.	Subsection 5.4.14 Subsection 5.4.20
b2	When the value of the disconnection detection status (BFM #28) changes, the status value is transferred to the data register specified by BFM #63.	Subsection 5.4.9 Subsection 5.4.21
b3 to b15	Invalid (setting values unchanged)	-

2. Cautions regarding the status automatic transfer function

- While changing the settings, the output is stopped, and H0000 is automatically written in the output status (BFM #6).
 At the completion of writing, the output status (BFM #6) will automatically change to H1111, and the output will be restarted.

3. Cautions regarding EEPROM writing

If data is written to BFM #0, #5, #10 to #17, #32 to #35, #50 to #54 or #60 to #63, the data will also be written in the EEPROM of FX3U-4DA.

Do not turn off the power immediately after writing values in these buffer memories.

The maximum number of EEPROM rewritable times is 10,000. When creating a program, therefore, do not frequently write data in the above buffer memories (BFM).

5.4.19 BFM #61: Error status data automatic transfer-to data register specification

Setting range: 0 to 7999
Initial value: K200
Numeric data type: Decimal (K)

Use this function to automatically transfer the error status data (BFM #29) to the data register specified in BFM #61.

When an error is detected, data will be automatically transferred from FX3U-4DA to the PLC. For this reason, the PLC does not need a program for reading data, and the scan time of the PLC can be shortened.

→ For a detailed description of the error status (BFM #29), refer to Subsection 5.4.12.

1. If "BFM #61 = K200 (initial value)"

Specified data register	Description
D200	Value of error status (BFM #29)

2. Cautions regarding error status automatic transfer function setting

- If a data is already specified for the other automatic transfer functions, do not specify the same data register.
- This function is valid by turning on b0 of the status automatic transfer function setting (BFM #60).
- When a value out of the above setting range is set, b9 of the error status BFM #29 is turned on.
- The data set in BFM #61 will be retained in the EEPROM.

3. Cautions regarding EEPROM writing

If data is set in BFM #0, #5, #10 to #17, #32 to #35, #50 to #54 or #60 to #63, the data will be written in the EEPROM of FX3U-4DA.

Do not turn off the power immediately after writing values in these buffer memories.

The maximum number of EEPROM rewritable times is 10,000. Therefore, when creating a program, do not frequently write data in the above buffer memories (BFM).

A	Common Items
B	FX3U-4AD FX3UC-4AD
C	FX3U-4AD-ADP
D	FX3G-2AD-BD
E	FX3U-4DA
F	FX3U-4DA-ADP
G	FX3G-1DA-BD
H	FX3U-3A-ADP
I	FX3U-4AD-PT -ADP
J	FX3U-4AD-PTW -ADP

5.4.20 BFM #62: Upper/lower limit function status data automatic transfer-to data register specification

Setting range: 0 to 7999
Initial value: K201
Numeric data type: Decimal (K)

Use this function to automatically transfer the upper/lower limit function status data (BFM #39) to the data register specified in BFM #62.

Only when the value becomes more than the upper limit or less than the lower limit, data will be automatically transferred from FX3U-4DA to the PLC. For this reason, the PLC does not need the program to read data, and the scan time of the PLC can be shortened.

→ For a detailed description of the upper/lower limit function status (BFM #39), refer to Subsection 5.4.14.

1. If "BFM #62 = K201 (initial value)"

Specified data register	Description
D201	Value of upper/lower limit function status (BFM #39)

2. Cautions regarding upper/lower limit function status automatic transfer function setting

- If a data is already specified for the other automatic transfer functions, do not specify the same data register.
- This function is valid by turning on b1 of the status automatic transfer function setting (BFM #60).
- When a value out of the above setting range is set, b9 of the error status BFM #29 is turned on.
- The data set in BFM #62 will be retained in the EEPROM.

3. Cautions regarding EEPROM writing

If data is set in BFM #0, #5, #10 to #17, #19, #32 to #35, #50 to #54 or #60 to #63, the data will be written in the EEPROM of FX3U-4DA.

Do not turn off the power immediately after writing values in these buffer memories.

The maximum number of EEPROM rewritable times is 10,000. When creating a program, therefore, do not frequently write data in the above buffer memories (BFM).

5.4.21 BFM #63: Specification of data register for automatic transfer at disconnection detection

Setting range: 0 to 7999
Initial value: K202
Numeric data type: Decimal (K)

Use this function to automatically transfer the disconnection detection status data (BFM #28) to the data register specified in BFM #63.

Only when wire-break is detected, data will be automatically transferred from FX3U-4DA to the PLC. For this reason, the PLC does not need the program for reading data, and the scan time of the PLC can be shortened.

→ For a detailed description of the disconnection detection status (BFM #28), refer to Subsection 5.4.9.

1. If "BFM #63 = K202 (initial value)"

Specified data register	Description
D202	Value of disconnection detection status (BFM #28)

2. Cautions regarding disconnection detection status automatic transfer function setting

- If a data is already specified for the other automatic transfer functions, do not specify the same data register.
- This function is valid by turning on b2 of the status automatic transfer function setting (BFM #60).
- When a value out of the above setting range is set, b9 of the error status BFM #29 is turned on.
- The data set in BFM #63 will be retained in the EEPROM.

3. Cautions regarding EEPROM writing

If data is set in BFM #0, #5, #10 to #17, #19, #32 to #35, #50 to #54 or #60 to #63, the data will be written in the EEPROM of FX3U-4DA.

Do not turn off the power immediately after writing values in these buffer memories.

The maximum number of EEPROM rewritable times is 10,000. Therefore, when creating a program, do not frequently write data in the above buffer memories (BFM).

5.4.22 BFM #80 to #3098: Table output function

Related BFM:

- BFM #80 (start/stop command of table output function)
- BFM #81 to #84 (output pattern setting of channels)
- BFM #85 to #88 (output execution cycle number of channels)
- BFM #89 (completion flag of table output function)
- BFM #90 (table output error code)
- BFM #91 (table output error source number)
- BFM #98 (data table head device number)
- BFM #99 (data table transfer command)
- BFM #100 to #398, ..., #2800 to #3098 (data table in patterns)

Table output function: Sets predetermined output patterns as data table, and outputs analog signals according to the data table.

→ For a detailed description of the table output function, refer to Chapter 6.

6. Table Output Function

This chapter describes the table output function of FX3U-4DA

6.1 Outline of Table Output Function

1. Explanation of the function

This function sets predetermined output patterns as data table and outputs analog signals according to the data table.

2. Outline of procedures for table output function

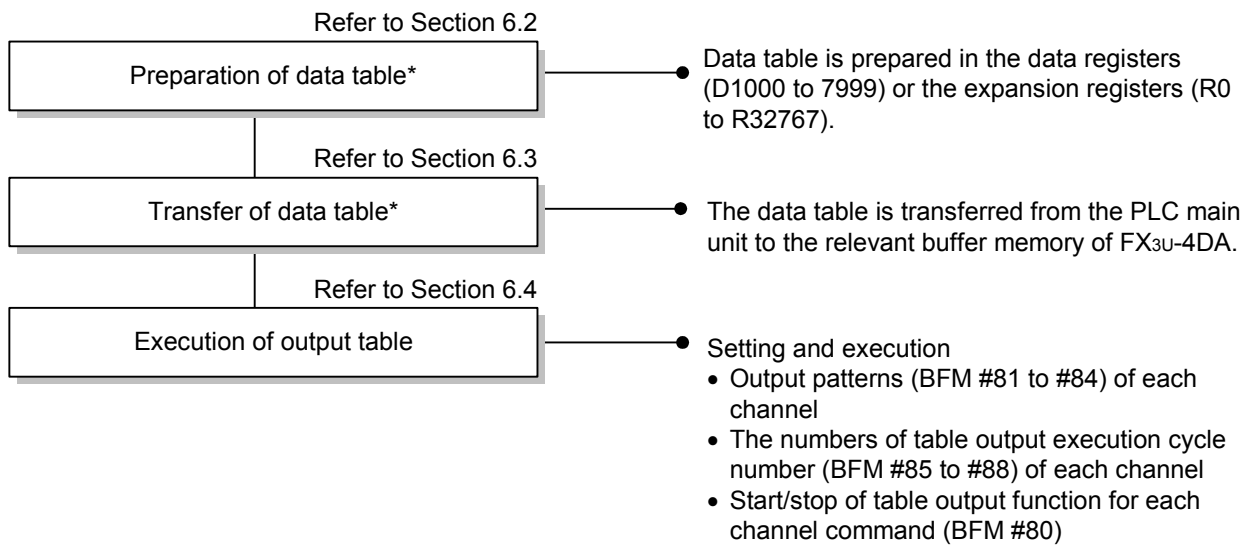

* It is possible to write the data table directly in FX3U-4DA using a program (TO instruction, etc.).

6.2 Preparation of data table

1. Outline of data table

The data table to be prepared in the PLC consists of the following items.

- (1) Number of patterns (1 to 10 patterns)
- (2) Each pattern
 - (3) Number of points in each pattern (1 to 99 points)
 - (4) Condition after output at final point in each pattern
 - (5) Points in each pattern
 - (6) Data to be output at each point
 - (7) Output update time at each point
 - (8) Unit of output update time at each point, and point-to-point interpolation method

2. Preparation of data table

Prepare the data table consisting of the following items in the data registers (D1000 to D7999) in the PLC main unit or the expansion registers (R0 to R32767).

It is convenient to prepare the data table on spreadsheet software and copy and paste the data to the device memory of GX Developer.

Setting item		Device number in PLC assignment	
(1) Number of patterns (x)		Device number specified in BFM #98	
(2) Pattern 1	(3) Number of points in pattern 1 (n)	Device number+1 specified in BFM #98	
	(4) Condition after output at final point in pattern	Device number+2 specified in BFM #98	
	(5) Point 1	(6) Output data	Device number+3 specified in BFM #98
		(7) Output update time	Device number+4 specified in BFM #98
		(8) Unit of output update time at each point, and point-to-point interpolation method	Device number+5 specified in BFM #98
	·	·	·
	(5) Point n	(6) Output data	·
		(7) Output update time	
(8) Unit of output update time at each point, and point-to-point interpolation method			
·	·	·	
(2) Pattern X	(3) Number of points in pattern X (m)	·	
	(4) Condition after output at final point in pattern		
	(5) Point 1		(6) Output data
			(7) Output update time
			(8) Unit of output update time at each point, and point-to-point interpolation method
	·		·
	(5) Point m		(6) Output data
			(7) Output update time
(8) Unit of output update time at each point, and point-to-point interpolation method		Device specified in BFM #98 + total number of data tables - 1*1	

Note) The device number marked by *1 should not exceed D7999 or R32767.
 For a detailed description of the data table items (1) to (8), refer to the following pages.

A
Common Items

B
FX3U-4AD
FX3UC-4AD

C
FX3U-4AD-ADP

D
FX3G-2AD-BD

E
FX3U-4DA

F
FX3U-4DA-ADP

G
FX3G-1DA-BD

H
FX3U-3A-ADP

I
FX3U-4AD-PT-ADP

J
FX3U-4AD-PTW-ADP

3. Details of data table

- (1) Number of patterns (number of data items: 1)
 Store the number of patterns at the top of the data table (device specified in BFM #98).
 Up to 10 patterns can be prepared. The setting range of the number of patterns is 1 to 10.
 When the number of patterns is out of the setting range, table output error code K111 is stored in BFM #90, the device number in which the number of patterns is specified is stored in BFM #91, and b8 in error status BFM #29 is turned on.
- (2) Pattern (number of data items: 5 to 299)
 A pattern refers to a predetermined flow of output. The contents of a pattern are defined by a combination of points.
 Prepare pattern data following the number of patterns to form the data table.
 Up to 10 patterns can be prepared.
- (3) Number of points (number of data items: 1)
 Store the number of points to be used in each pattern at the top of the pattern.
 Up to 99 points can be provided. The setting range of number of points is 1 to 99.
 When the number of points is out of the setting range, the error code is stored in the table output error code BFM #90, the device number or the buffer memory that has developed the table output error is stored in BFM #91, and b8 of the error status BFM #29 is turned on.
- (4) Condition after output at final point in pattern (number of data items: 1)
 The condition after output at the final point in a pattern can be set to continue to output the output signal at the final point or output the offset signal.
 The setting is shown in the following table.

Set value	Condition after output at final point
K0	Continuing to output the output signal at the final point
K1	Outputting the offset signal
Other than above values	Invalid*

* When a value out of the setting range is set, the error code is stored in the table output error code BFM #90, the device number or the buffer memory that has developed the table output error is stored in BFM #91, and b8 of the error status BFM #29 is turned on.

- (5) Point (number of data items: 3)
 Data output point. The data indicating a point consist of output data, output update time, output update time unit and point-to-point interpolation method.
 Each pattern can have up to 99 points.
- (6) Output data (number of data items: 1)
 Digital value corresponding to the analog signal to be output at the point
 The setting range depends on the output mode and offset/gain setting.
- (7) Output update time (number of data items: 1)
 Output time to the next point. The output update time for the n-th point is the output time between the n-th point and the (n+1)-th point.
 When the pattern is repeated, the output update time at the final point is used as the output time between the final point and the first point.
 When the pattern is not repeated, the output update time for the final point is ignored.
 The setting range is 1 to 32767. For the unit, refer to Item (8).
 When a value out of the setting range is set, the error code is stored in the table output error code BFM #90, the device number or the buffer memory that has developed the table output error is stored in BFM #91, and b8 of the error status BFM #29 is turned on.

- (8) Output update time unit and point-to-point interpolation method (number of data items: 1)
 Set the unit of the output update time and the point-to-point interpolation method for each point.
 The output update time unit and the point-to-point interpolation method for the n-th point are applied between the n-th point and the (n+1)-th point.
 When the pattern is repeated, the output update time unit and the point-to-point interpolation method are applied between the final point and the first point.
 When the pattern is not repeated, the output update time unit and the point-to-point interpolation method for the final point are ignored.
 A 4-digit hexadecimal number, H○○○○, is allocated as shown below.

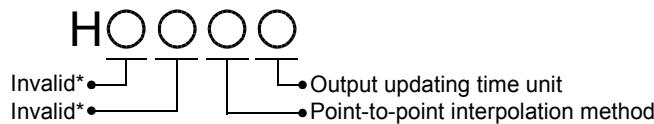

- Setting of output update time unit

Set value	Output update time unit
0	10 ms
1	100 ms
2	1 s
3	1 min
Other than above values	Invalid*

- Interpolation method

Data output between points are interpolated every 1 ms and automatically updated.

Set value	Interpolation method
0	No interpolation (Output data is held to the next point.)
1	Linear interpolation (Data output between points are interpolated in the shape of a straight line.)
2	S-shaped interpolation (Data output between points are interpolated in the shape of an S-shaped as shown below.)
Other than above values	Invalid*

- S-shaped interpolation

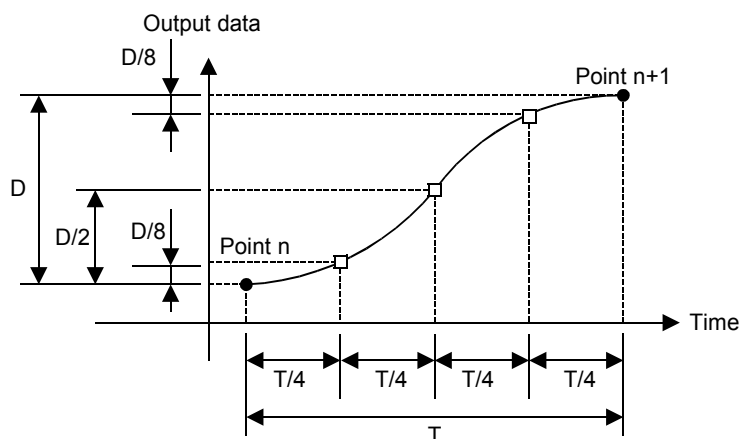

* When a value out of the setting range is set, the error code is stored in the table output error code BFM #90, the device number or the buffer memory that has developed the table output error is stored in BFM #91, and b8 of the error status BFM #29 is turned on.

4. Example of data table

The following table shows an example of data table containing two patterns prepared in and after D5000. Patterns 1 and 2 are in the output mode 1.

Data register	Set value	Description		
D5000	K2	Number of patterns	2 patterns	
D5001	K3	Pattern 1	Number of points in pattern 1	
D5002	K0		Setting of condition after output at final point in pattern 1	
D5003	K3000		Point 1	Data to be output at point 1 in pattern 1
D5004	K18			Output update time at point 1 in pattern 1
D5005	H0021			Output update time unit at point 1 in pattern 1 Point-to-point interpolation method
D5006	K8000		Point 2	Data to be output at point 2 in pattern 1
D5007	K26			Output update time at point 2 in pattern 1
D5008	H0011			Output update time unit at point 2 in pattern 1 Point-to-point interpolation method
D5009	K5000		Point 3	Data to be output at point 3 in pattern 1
D5010	K5			Output update time at point 3 in pattern 1
D5011	H0011			Output update time unit at point 3 in pattern 1 Point-to-point interpolation method
D5012	K4		Pattern 2	Number of points in pattern 2
D5013	K1			Setting of condition after output at final point in pattern 2
D5014	K2000	Point 1		Data to be output at point 1 in pattern 2
D5015	K6			Output update time at point 1 in pattern 2
D5016	H0022			Output update time unit at point 1 in pattern 2 Point-to-point interpolation method
D5017	K10000	Point 2		Data to be output at point 2 in pattern 2
D5018	K15			Output update time at point 2 in pattern 2
D5019	H0002			Output update time unit at point 2 in pattern 2 Point-to-point interpolation method
D5020	K500	Point 3		Data to be output at point 3 in pattern 2
D5021	K45			Output update time at point 3 in pattern 2
D5022	H0021			Output update time unit at point 3 in pattern 2 Point-to-point interpolation method
D5023	K4000	Point 4		Data to be output at point 4 in pattern 2
D5024	K9			Output update time at point 4 in pattern 2
D5025	H0012		Output update time unit at point 4 in pattern 2 Point-to-point interpolation method	

5. Example of pattern output

Data can be output in a predetermined pattern as shown below. (Example of pattern 1 in output mode 1 shown on the previous page)

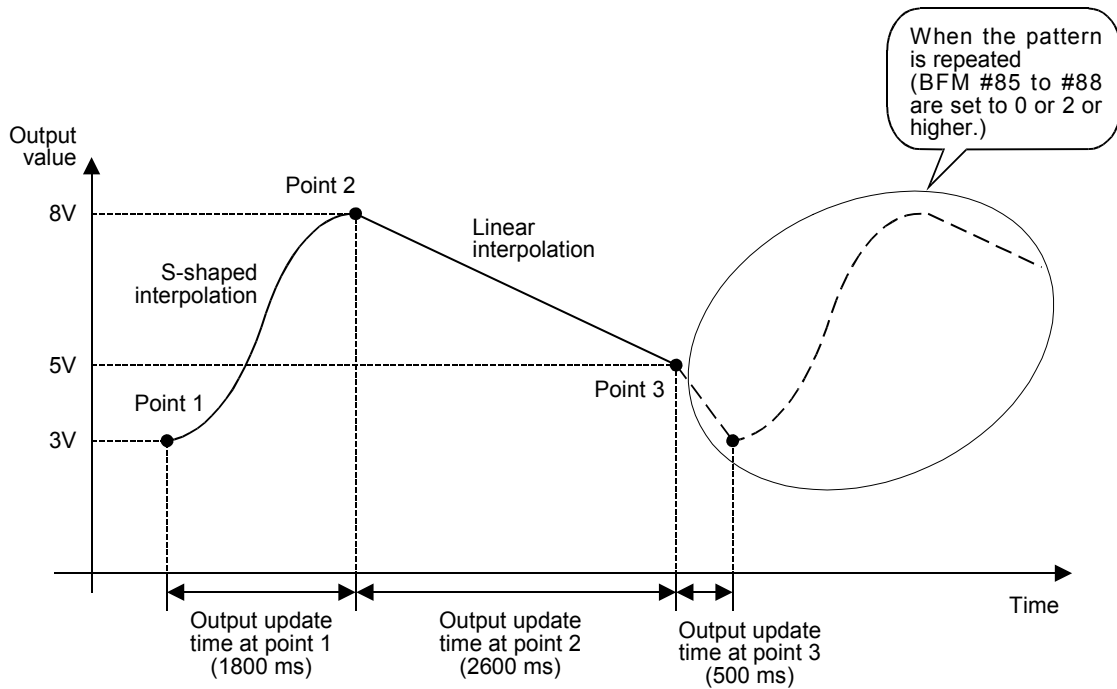

6. Caution when preparing the data table

- Prepare the data table in continuous data registers in the PLC main unit or continuous expansion registers. (Prepare data without spaces between patterns or points.)
 If data has spaces, the data cannot be transferred normally to the buffer memory in FX3U-4DA.
 → For a detailed description of data table errors, refer to Section 6.5.

A Common Items
B FX3U-4AD, FX3UC-4AD
C FX3U-4AD-ADP
D FX3G-2AD-BD
E FX3U-4DA
F FX3U-4DA-ADP
G FX3G-1DA-BD
H FX3U-3A-ADP
I FX3U-4AD-PT-ADP
J FX3U-4AD-PTW-ADP

6.3 Procedures for transferring data table to buffer memory

The data table prepared in the data registers (D1000 to D7999) in the PLC or the expansion registers (R0 to R32767) are transferred to the buffer memory in FX3U-4DA.
 The transfer procedures are shown below.

1. Specify the head device number of the data table to be transferred. (BFM #98, initial value: K1000)

Specify the head device number of the data table in BFM #98.

The setting range is K1000 to K7994 for the data registers (D1000 to D7999) (because at least six points are occupied) or K0 to K32762 for the expansion registers (R0 to R32767) (because at least six points are occupied).

Example) When the data table is set starting from D1000, set K1000 in BFM #98.

When a value out of the setting range is set, the error code K21 is stored in the table output error code BFM #90, the number of the buffer memory, K98, that has developed the table output error is stored in BFM #91, and b8 of the error status BFM #29 is turned on.

2. Start transferring the data table. (BFM #99, initial value: H0000)

Transfer the data table from the PLC to the FX3U-4DA using the data table transfer command (BFM #99).

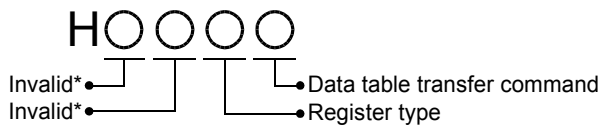

- Data table transfer command

Set value	Transfer command
0	No processing
1	Execution of transfer of data table
Other than above values	Invalid*

- Register type

Set value	Register type
0	Transfer of data table from data registers (D1000 to 7999)
1	Transfer of data table from expansion registers (R0 to 32767)
Other than above values	Invalid*

* When a value out of the setting range is set, the error code is stored in the table output error code BFM #90, the number of the buffer memory, K99, that has developed the table output error is stored in BFM #91, and b8 of the error status BFM #29 is turned on.

Example) When K1000 is written in the head device number of data table (BFM #98) and H0001 is written in the data table transfer command (BFM #99), the data table will be transferred from the data register D1000.

3. Buffer memory contents in FX3U-4DA after transfer

The transferred data table is stored in the following buffer memory areas.

BFM number	Description		
#100	Pattern 1	Number of points	
#101		Condition after output at final point in pattern	
#102		Point 1	Output data
#103			Output update time
#104			Unit of output update time at each point, and point-to-point interpolation method
.		.	.
.		.	.
.		.	.
#396		Point 99	Output data
#397			Output update time
#398	Unit of output update time at each point, and point-to-point interpolation method		
#399	Not used		
.	.	.	
.	.	.	
#2800	Pattern 10	Number of points	
#2801		Condition after output at final point in pattern	
#2802		Point 1	Output data
#2803			Output update time
#2804			Unit of output update time at each point, and point-to-point interpolation method
.		.	.
.		.	.
.		.	.
#3096		Point 99	Output data
#3097			Output update time
#3098	Unit of output update time at each point, and point-to-point interpolation method		

A
Common Items

B
FX3U-4AD
FX3UC-4AD

C
FX3U-4AD-ADP

D
FX3G-2AD-BD

E
FX3U-4DA

F
FX3U-4DA-ADP

G
FX3G-1DA-BD

H
FX3U-3A-ADP

I
FX3U-4AD-PT-ADP

J
FX3U-4AD-PTW-ADP

4. Example of transfer of data table

The data table below shows the writing of K5000 to BFM#98 and H0001 to BFM#99. Data starting from D5000 is transferred to the buffer memory in the FX3U-4DA.

PLC main unit			FX3U-4DA		
Data register	Set value		BFM number	Set value	Source data register
D5000	K2		#100	K3	D5001
D5001	K3		#101	K0	D5002
D5002	K0		#102	K3000	D5003
D5003	K3000		#103	K18	D5004
D5004	K18		#104	H0021	D5005
D5005	H0021		#105	K8000	D5006
D5006	K8000		#106	K26	D5007
D5007	K26		#107	H0011	D5008
D5008	H0011		#108	K5000	D5009
D5009	K5000		#109	K5	D5010
D5010	K5		#110	H0011	D5011
D5011	H0011		:		
D5012	K4		:	-	-
D5013	K1		#400	K4	D5012
D5014	K2000		#401	K1	D5013
D5015	K6		#402	K2000	D5014
D5016	H0022		#403	K6	D5015
D5017	K10000		#404	H0022	D5016
D5018	K15		#405	K10000	D5017
D5019	H0002		#406	K15	D5018
D5020	K500		#407	H0002	D5019
D5021	K45		#408	K500	D5020
D5022	H0021		#409	K45	D5021
D5023	K4000		#410	H0021	D5022
D5024	K9		#411	K4000	D5023
D5025	H0012		#412	K9	D5024
			#413	H0012	D5025

Transfer to buffer
memory



5. Cautions regarding data table transfer

- While the table output function is executed, it is impossible to start transferring the data table.
- The number of patterns is not transferred to the buffer memory in FX3U-4DA.
- The transferred data table is stored in the buffer memory in FX3U-4DA. The data table stored in FX3U-4DA will be erased when power is turned off. Therefore, it is necessary to transfer the data table after rebooting the power.
- At completion of transfer, BFM #99 will automatically change to H0000. Also when transfer is stopped due to an error, BFM #99 will automatically change to H0000. When BFM #99 changes to H0000, check the error flag.
 → **For a detailed description of errors related to table output, refer to Subsection 6.5.**
- If an error occurs during transfer of the data table, the data up to the error is transferred. Subsequent data is not transferred.
- It is possible to write the data table directly in the buffer memory without using the data table transfer command (BFM #99).
 In this case, the correctness of the data table is not evaluated until the table is output by the table output start/stop function (BFM #80).
 If a data table with incorrect data is output, the data up to the point where incorrect data occurs is output. At the point where incorrect data occurs, an error is registered and only the data output just before the occurrence of the error is held.
- Execute the data table transfer command (BFM #99) as a pulse execution type instruction.
- During transfer of the data table, the scan time increases by up to about 10 ms.
- The standard data table transfer time is obtained by the following formula.

$$\text{Transfer time} = (\text{Scan time}) \times \left(\frac{\text{Number of data table items}}{64} \right)^* \times (\text{number of FX3U-4DA units connected to main unit})$$

* Fractions omitted

Example)

- Scan time: 50 ms (including increase in scan time caused by data table transfer)
- Number of data table items to be transferred: 2991 items (when the number of patterns is 10 and the number of points in each pattern is 99)
- Number of units connected to FX3U-4DA: 8 units

$$\begin{aligned} \text{Transfer time} &= (50 \text{ ms}) \times \left(\frac{2991}{64} \right) \times (8 \text{ units}) \\ &= 18800 \text{ ms} \end{aligned}$$

A	Common Items
B	FX3U-4AD FX3UC-4AD
C	FX3U-4AD-ADP
D	FX3G-2AD-BD
E	FX3U-4DA
F	FX3U-4DA-ADP
G	FX3G-1DA-BD
H	FX3U-3A-ADP
I	FX3U-4AD-PT-ADP
J	FX3U-4AD-PTW-ADP

6.4 Procedures for executing table output function

After setting the output patterns for the channels (BFM #81 to #84) and the number outputs for the channels (BFM #85 to #88), turn on the table output function start/stop command (BFM #80) to execute the table output function.

1. Set the output patterns for the channels. (BFM #81 to #84, initial value: K1)

Set the output patterns for the channels in BFM #81 to #84.

The output pattern can be changed in the middle of outputting the table.

Setting range for BFM #81 to #84: 1 to 10

When a value out of the setting range is set, the error code K31 is stored in the table output error code BFM #90, the number of the buffer memory (K81 to K84) that has developed the table output error is stored in BFM #91, and b8 of the error status BFM #29 is turned on.

2. Set the number of table outputs for the channels. (BFM #85 to #88, initial value: K0)

Set the number of table outputs for the channels in BFM #85 to #88.

The number of outputs can be changed even during outputting the table.

Setting range for BFM #85 to #88: 0 to 32767

When 0 is set, output of the table will be repeated until the table output is stopped by BFM #80.

When a value out of the setting range is set, the error code K32 is stored in the table output error code BFM #90, the number of the buffer memory (K85 to K88) that has developed the table output error is stored in BFM #91, and b8 of the error status BFM #29 is turned on.

3. Table output start/stop (BFM #80, initial value: H0000)

Table output is started and stopped by setting BFM #80 as shown below.

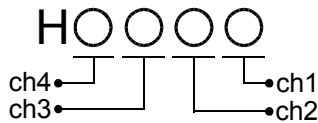

Set value	Description
0	The table output function of each channel is stopped.
1	The table output function of each channel is started. After output of the final point in the last cycle, 0 will be automatically written.
Other than above values	Invalid*

* When a value out of the setting range is set, the error code K33 is stored in the table output error code BFM #90, the number of the buffer memory (K80) that has developed the table output error is stored in BFM #91, and b8 of the error status BFM #29 is turned on.

4. Cautions regarding table output

- When BFM #99 (data table transfer command) is not H0000, the table output function cannot be started.
- When an error occurs during transfer of data table, start the table output after setting the correct data table.
- While the table output completion flag BFM #89 is ON, output of a new table cannot be started.
- The table output function is valid only while the PLC is in RUN mode.
- While even a single channel is outputting data table (BFM #80 is not H0000), it is prohibited to change BFM #0, #5, #9 to #17, #19, #20, #32 to #35, #38, #41 to 48, #50 to #54 and #60 to #63.
- The pattern can be changed during output as shown below. (The change is invalid while the table output completion flag BFM #89 is ON.)

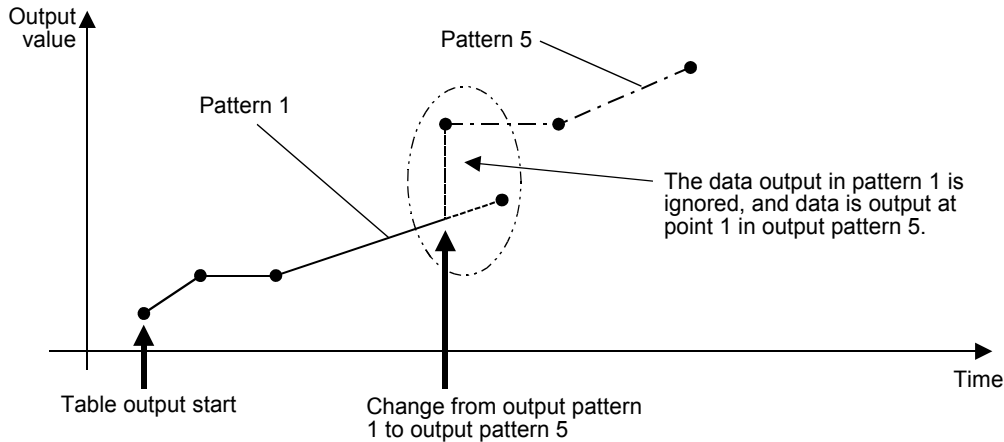

5. Check the table output completion flag. (BFM #89, initial value: H0000)

The value in BFM #89 indicates whether the table output from each channel has been completed. After data is output at the final point in the last cycle of a pattern, the table output completion flag is turned on. When the table output (BFM#80) is set to be stopped, the table output completion flag is turned off.

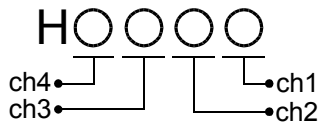

Value for each channel	Table output completion flag
0	Table output uncompleted
1	Table output completed

A Common Items
B FX3U-4AD, FX3UC-4AD
C FX3U-4AD-ADP
D FX3G-2AD-BD
E FX3U-4DA
F FX3U-4DA-ADP
G FX3G-1DA-BD
H FX3U-3A-ADP
I FX3U-4AD-PT-ADP
J FX3U-4AD-PTW-ADP

6.5 Details of table output error

When an error related to the table output function occurs, the error code is stored in BFM #90, and the device number or the buffer memory that has developed the error is stored in BFM #91.

1. Error code table and details of error source numbers

Error code (BFM #90)	Details of error	Table output error source number (BFM #91)
K111	The number of patterns in the data table that is held in the PLC does not meet the following requirement. $1 \leq \text{Number of patterns} \leq 10$	Device number where the number of patterns is specified (same as the head device number in the data table)
K121	The number of points in the data table that is held in the PLC does not meet the following requirement. $1 \leq \text{Number of patterns} \leq 99$	Device number where the number of patterns is specified
K122	The number of points in the data table that is held in the buffer memory does not meet the following requirement. $1 \leq \text{Number of points} \leq 99$	Number of BFM where the number of points is specified
K131	"The condition after output at final point in pattern" specified in the data table that is held in the PLC is not 0 or 1.	Device number where "the condition after the final point output point in pattern" is specified
K132	"The condition after output at final point in pattern" specified in the data table that is held in the buffer memory is not 0 or 1.	Number of BFM where "the condition after output point in the pattern" is specified
K151	The output update time in the data table that is held in the PLC does not meet the following requirement. $1 \leq \text{Output update time} \leq 32767$	Device number where the output update time is specified
K152	The output update time in the data table that is held in the buffer memory does not meet the following requirement. $1 \leq \text{Output update time} \leq 32767$	Number of BFM where the output update time is specified
K161	The output update time unit in the data table that is held in the PLC is not 0, 1, 2 or 3.	Device number where the output update time unit is specified
K162	The output update time unit in the data table that is held in the buffer memory is not 0, 1, 2 or 3.	Number of BFM where the output update time unit is specified
K171	The interpolation method in the data table that is held in the PLC is not 0, 1 or 2.	Device number where the interpolation method is specified
K172	The interpolation method in the data table that is held in the buffer memory is not 0, 1 or 2.	Number of BFM where the interpolation method is specified
K21	The head device number BFM #98 in the data table to be transferred is out of the setting range.	K98
K22	The value indicated by b0 to b3 of the transfer command BFM #99 is not 0 or 1.	K99
K23	The value indicated by b4 to b7 of the source register type in BFM #99 is not 0 or 1.	K99
K31	Any of the output patterns BFM #81 to #84 does not meet the following requirement. $1 \leq \text{Output pattern} \leq 10$	One of K81 to K84
K32	The number of table outputs in BFM #85 to #88 does not meet the following requirement. $0 \leq \text{Number of repetitions of output} \leq 32767$	One of K85 to K88
K33	The bit corresponding to each channel in the table output start/stop command in BFM #80 is not 0 or 1.	K80

2. Cautions regarding table output errors

- Errors in data table
 When the data table in the PLC contains an error, the error can be detected during transfer of the data to the buffer memory in FX3U-4DA. In this case, the error code (BFM #90) is K1□1, and the device number is written as the error source (BFM #91).
 If an error is caused in the data table by directly rewriting the data in BFM after the data table is transferred, the error can be detected when the table is output using incorrect data. In this case, the error code (BFM #90) is K1□2, and the BFM number is written as the error source (BFM #91).
- Error during transfer of the data table
 While transferring of the data table, an error (error codes K31 to K33) does not occur even when the BFM #80 (table output function start/stop) is set to a value out of the setting range. An error occurs after the completion of the transfer of the data table.
- Error during output of the table
 Even if the output value is scaled over during output of the table, the output of the table will not be stopped. However, while the output value is scaled over, b10 (scale over) of the error status BFM #29 stays on. When an error (error codes K122 to K172, K31 to K33) occurs during output of the table, the output of the table is cancelled and the analog output value just before the occurrence of the error is retained.
- Table output errors (BFM #90) and table output error source numbers (BFM #91) are not retained. They will be cleared when the next data table transfer command is given or the table output start function is executed.

A
Common Items

B
FX3U-4AD
FX3UC-4AD

C
FX3U-4AD-ADP

D
FX3G-2AD-BD

E
FX3U-4DA

F
FX3U-4DA-ADP

G
FX3G-1DA-BD

H
FX3U-3A-ADP

I
FX3U-4AD-PT
-ADP

J
FX3U-4AD-PTW
-ADP

6.6 Examples uses of table output function

[Uses of table output function]

- Inverter frequency setting, servo speed control, etc.

1. Inverter frequency setting

The output frequency can be controlled by inputting analog signals (e.g. voltage from 0 to 10 V and current from 4 to 20 mA) to inverter frequency setting signals.

The analog signals and output signals have the following proportional relationship.

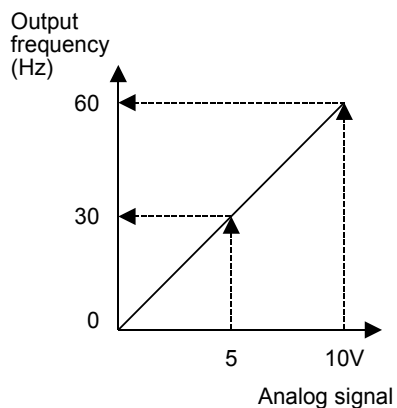

To control the frequency as shown below, where control the analog signal is proportional to the frequency use the table output function.

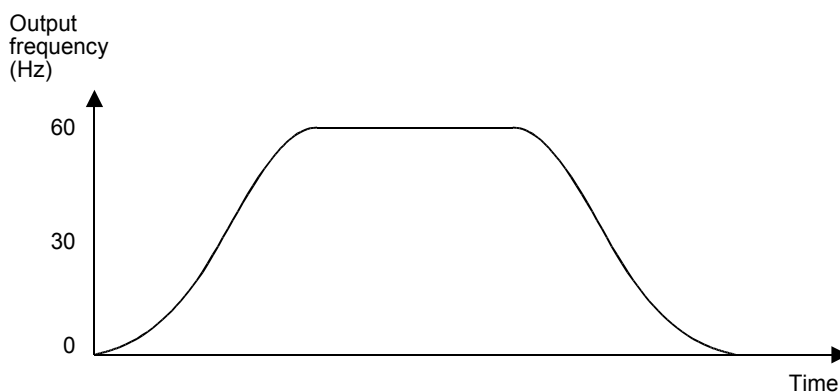

Example of table output

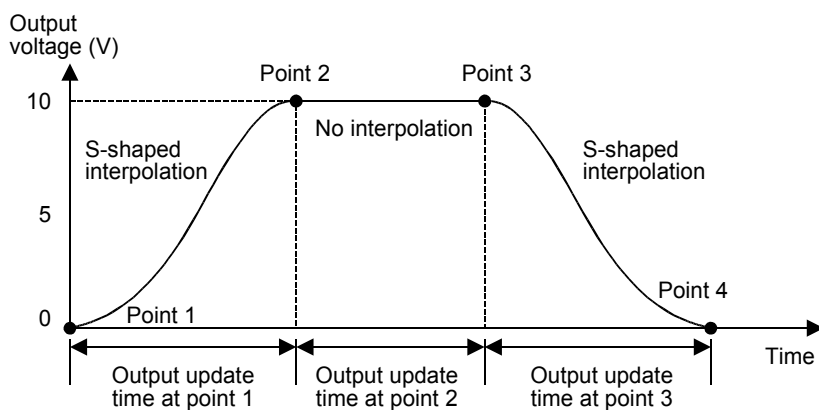

7. Changing Output Characteristics

For FX3U-4DA, the standard output characteristics are provided for each output mode (BFM #0) at the time of factory shipment.

Changing the offset data (BFM #10 to #13) and gain data (BFM #14 to #17) can change the output characteristics of each channel. This chapter describes how to change the output characteristics.

7.1 Procedure for Changing Output Characteristics

1 Cancel the setting change prohibition mode.

If setting change is prohibited, write K3030 in BFM #19. The setting change prohibition mode will be canceled.

2 Determine the output mode (BFM #0).

Determine the output mode (BFM #0) optimum for the selected channels and the voltage/current specifications.

Set value (HEX)	Output mode	Analog output range	Digital input range
0	Voltage output mode	-10V to +10V	-32000 to +32000
1	Voltage output analog value mV specification mode	The characteristic cannot be changed.	
2	Current output mode	0mA to 20mA	0 to 32000
3	Current output mode	4mA to 20mA	0 to 32000
4	Current output analog value μ A specification mode	The characteristic cannot be changed.	
5 to E	Setting not allowed	-	-
F	Channel not used	-	-

Example: Enter "HFF00" in BFM to set output mode 0 for channels 1 and 2 and prevent use channels 3 and 4

Cautions regarding data setting

- If a value "1" or "4" is set for a channel, the output characteristics of the channel cannot be changed.
- Set the optimum output mode for the analog signal to be output.

3 Determine the output characteristics to be changed.

Example: Change to output voltage of 1 to 5 V with digital values 0 to 32000

Output mode: 0

Output characteristics provided at the time of factory shipment

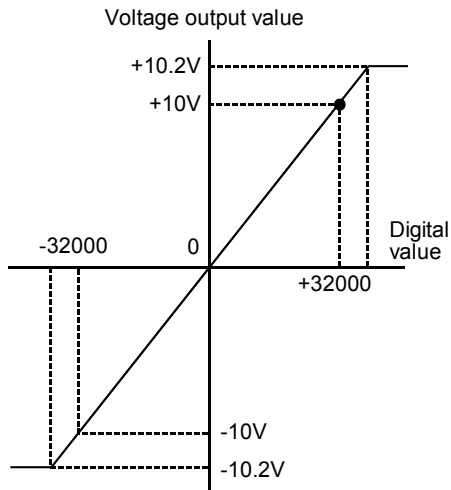

Output characteristics newly provided

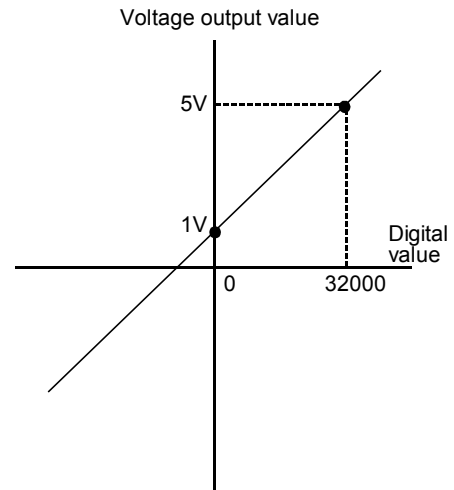

4 Determine the offset data.

Determine the analog output value for the digital output value of 0.

Set the analog output value in mV for the voltage output mode, and the analog output value in μA for the current output mode.

Example: To set the offset value of 1 V, set 1000 mV.

→ For a detailed description of the offset data, refer to Subsection 5.4.6.

5 Determine the gain data.

Determine the analog output value for the digital output value of 16000.

Set the analog output value in mV for the voltage output mode, and the analog output value in μA for the current output mode.

Example: To set the gain value of 3 V, set 3000 mV.

$$(5-1) \div 2 + 1 = 3\text{V (3000 mV)}$$

→ For a detailed description of the gain data, refer to Subsection 5.4.6.

6 Create a sequence program.

To change the output characteristics, write the offset data (BFM #10 to #13) and the gain data (BFM #14 to #17) in the sequence program, and then turn on the corresponding bit of BFM #9 for the corresponding channel.

Example: Program for changing the output characteristics of channels 1 and 2 (For FX3u, FX3uc Series PLCs):

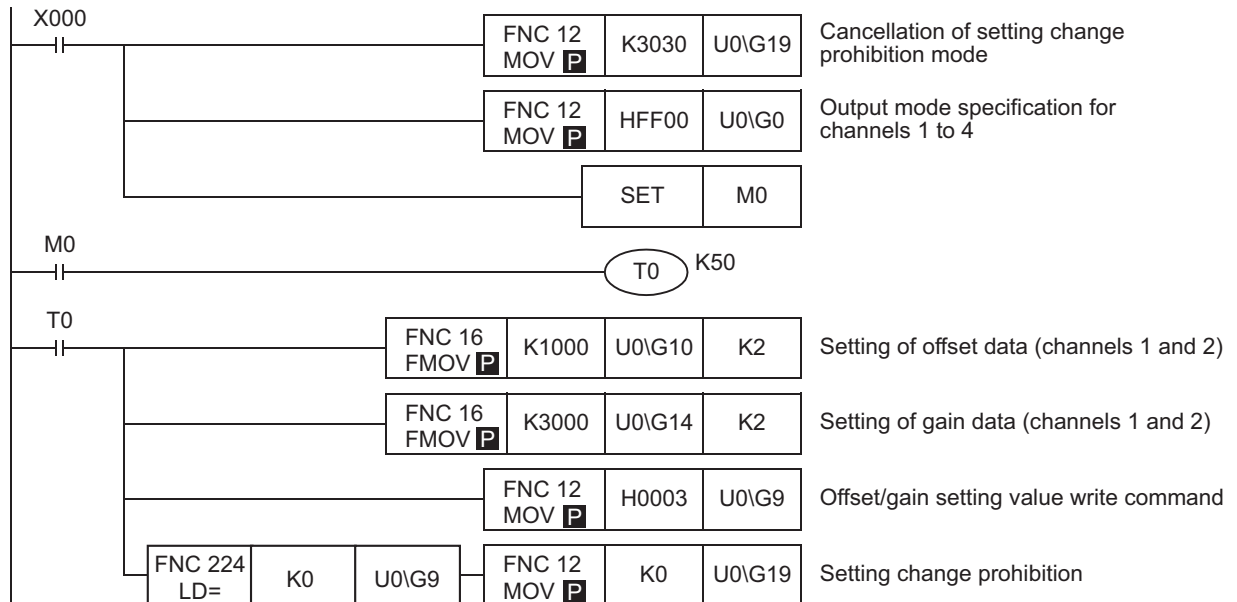

7 Transfer the sequence program to change the output characteristics.

Transfer the sequence program, and start the PLC.

After the PLC is started and the output characteristic write command (X000) is turned on, the offset data and gain data will be written.

Since the offset data and gain data are stored in the EEPROM incorporated in FX3U-4DA, it is possible to delete the pre-written sequence program.

8 Check the analog output signals

Check that the output analog signals correspond to the set output data.

→ If analog signals are not correctly output, refer to Chapter 9 "Troubleshooting."

8. Examples of Practical Programs

8.1 Example of Program for Analog Output Operation (Regular Operation)

When you want to use the initial output characteristics but do not need to use the status information, you can operate the PLC with a simple program as shown below.

1. Conditions

The sequence program described in this section is under the following conditions.

- 1) System configuration
 FX3U-4DA (unit No.0) should be connected to the FX3U Series PLC.
 - 2) Output mode
 Channels 1 and 2 should be set to mode 0 (voltage output, -10 V to +10 V).
 Channel 3 should be set to mode 3 (current output, 4 mA to 20 mA).
 Channel 4 should be set to mode 2 (current output, 0 mA to 20 mA).
- For FX3U, FX3UC Series PLCs

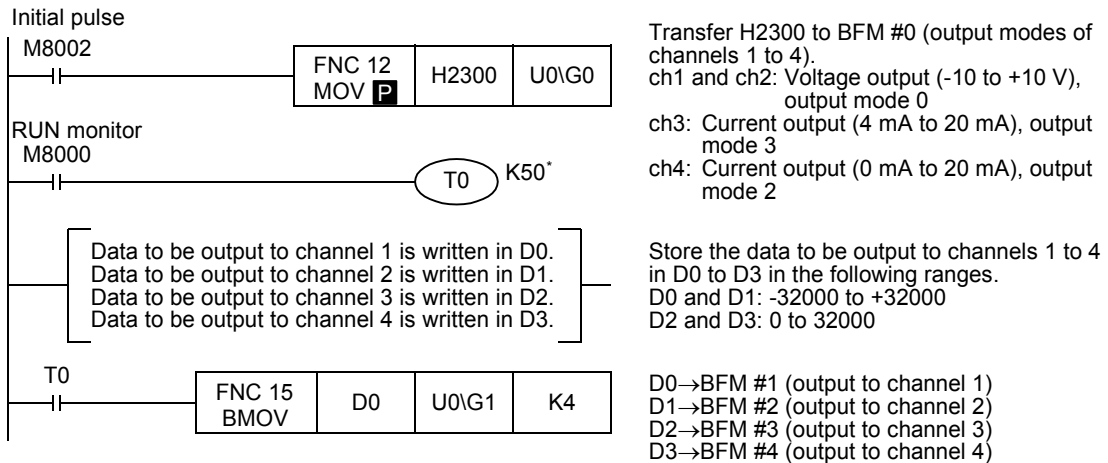

* After setting the output mode, set the data writing time (waiting time) to 5 seconds or more for each setting. The specified output mode will be retained even if power failure occurs. After the output mode is specified, if the same output mode is used, it is not necessary to set the output mode and the waiting time (T0 K50).

- For FX3G, FX3U, FX3UC Series PLCs

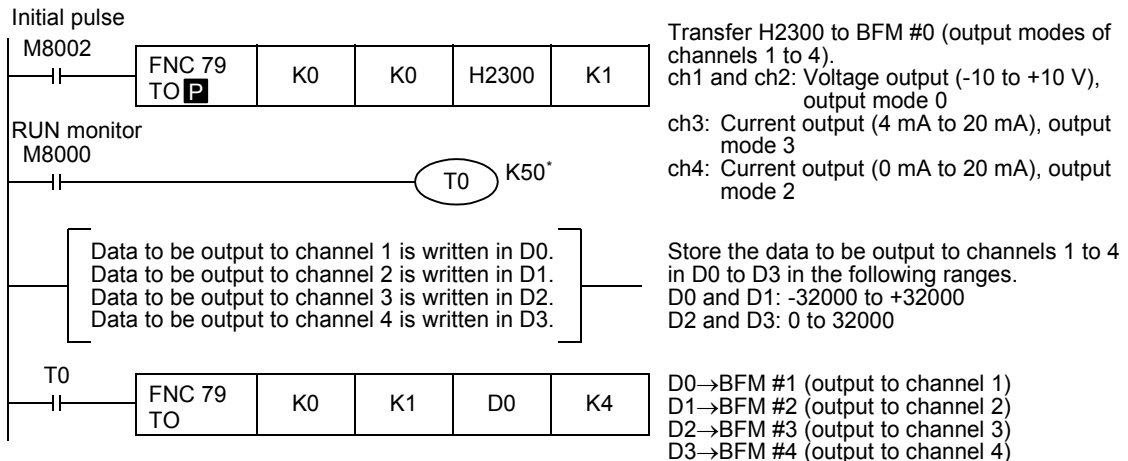

* After setting the output mode, set the data writing time (waiting time) to 5 seconds or more for each setting. The specified output mode will be retained even if power failure occurs. After the output mode is specified, if the same output mode is used, it is not necessary to set the output mode and the waiting time (T0 K50).

8.2 Example of Program using Useful Functions

This section describes a practical program that uses the disconnection detection function (BFM #28), upper/lower limit function (BFM #38 to #48), corrective function by load resistance (BFM #50 to #54) and status automatic transfer function (BFM #60 to #63) of FX3U-4DA.

1. Conditions

The sequence program described in this section is created under the following conditions.

- 1) System configuration
 FX3U-4DA (unit No.0) should be connected to the FX3U Series PLC.
- 2) Output mode
 Channels 1 and 2 should be set to mode 0 (voltage output, -10 V to +10 V).
 Channels 3 and 4 should be set to mode 2 (current output, 0 mA to 20 mA).
- 3) Convenient functions
 The disconnection detection function, upper/lower limit function, corrective function by load resistance and status automatic transfer function are used.
- 4) Device assignment

Device		Description
Input	X000	Clearance of upper/lower limit function status data
	X001	Clearance of error status data
	X002	Clearance of disconnection detection status data
	D10	Data to be output from channel 1
	D11	Data to be output from channel 2
	D12	Data to be output from channel 3
	D13	Data to be output from channel 4
Output	Y000	Output of channel-1 lower limit error data
	Y001	Output of channel-1 upper limit error data
	Y002	Output of channel-2 lower limit error data
	Y003	Output of channel-2 upper limit error data
	Y004	Output of channel-3 lower limit error data
	Y005	Output of channel-3 upper limit error data
	Y006	Output of channel-4 lower limit error data
	Y007	Output of channel-4 upper limit error data
	Y010	Output of disconnection detection signal
	Y011	Output of error detection signal
	D200	Data register at destination of automatic transfer of error status
	D201	Data register at destination of automatic transfer of upper/lower limit function error status
D202	Data register at destination of automatic transfer of disconnection detection error status	

2. Example of sequence program

- For FX3U, FX3UC Series PLCs

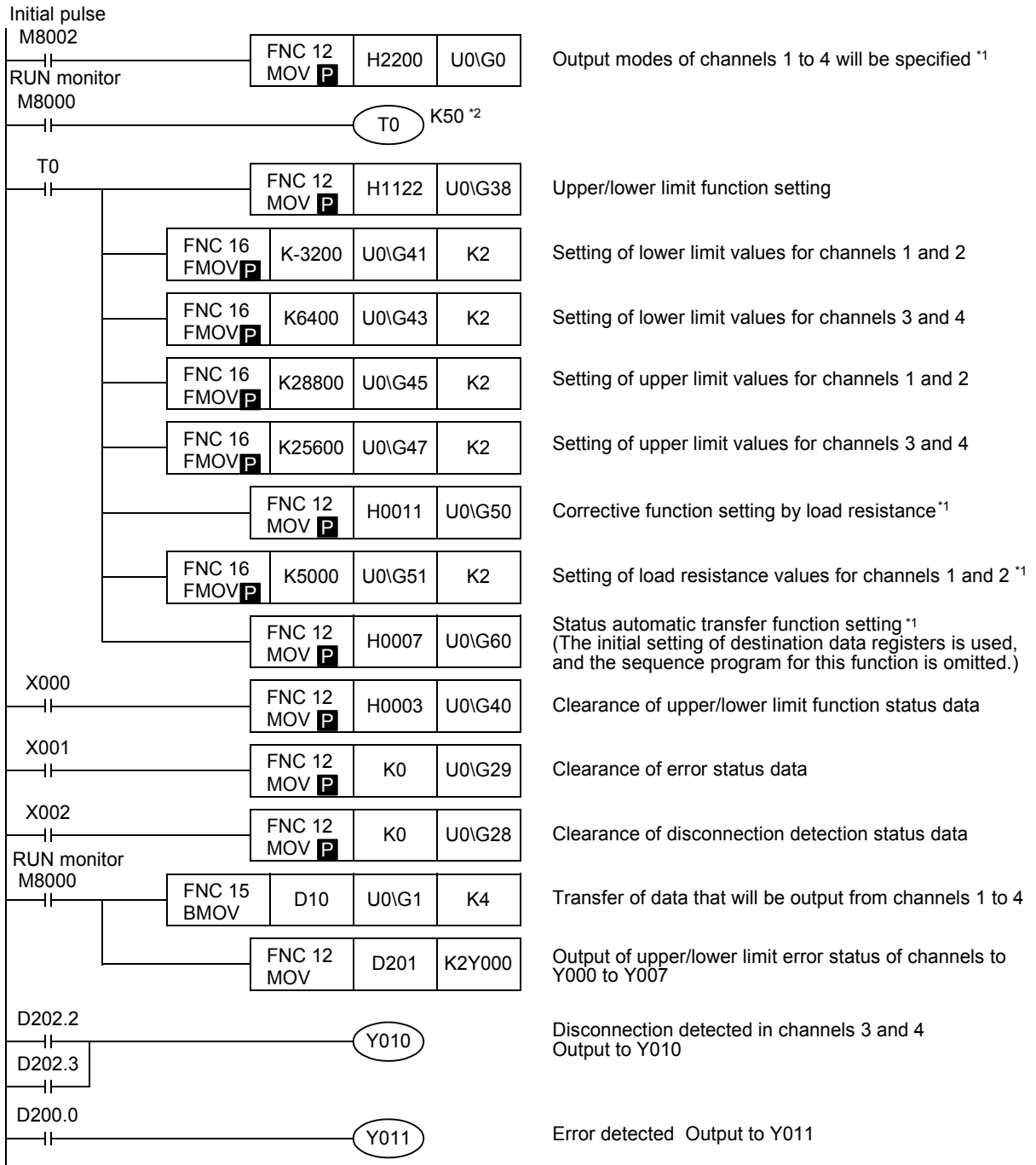

- *1. The output mode setting, setting of corrective function by load characteristics and status automatic transfer function setting are retained in the EEPROM of FX3u-4DA. For this reason, even if the sequence program is deleted, the previously set functions will still be valid.
- *2. After setting the output mode, set the data writing time (waiting time) to 5 seconds or more for each setting. After the output mode is specified, and the same output mode is used, it is not necessary to set the output mode and the waiting time (T0 K50).

- For FX3G, FX3U, FX3UC Series PLCs

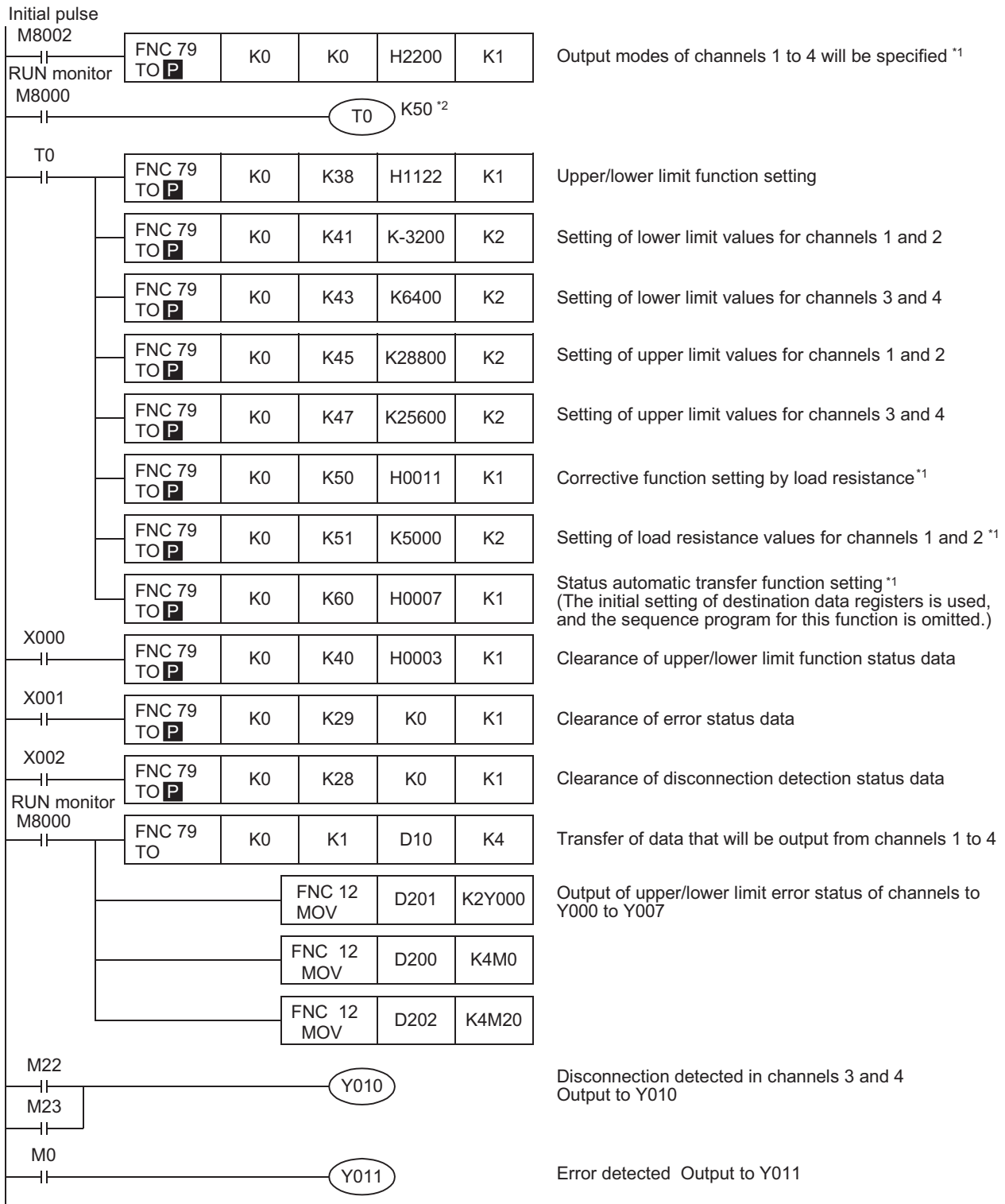

*1. The output mode setting, setting of corrective function by load characteristics and status automatic transfer function setting are retained in the EEPROM of FX3U-4DA. For this reason, even if the sequence program is deleted, the previously set functions will still be valid.

*2. After setting the output mode, set the data writing time (waiting time) to 5 seconds or more for each setting. After the output mode is specified, and the same output mode is used, it is not necessary to set the output mode and the waiting time (T0 K50).

8.3 Example of Program for Table Output Operation (Pattern Output Operation)

This section describes a practical program that uses the table output function.

1. Conditions

The sequence program described in this section is under the following conditions.

- 1) System configuration
 FX3U-4DA (unit No.0) should be connected to the FX3U Series PLC.
- 2) Output mode
 Channel 1 should be set to mode 0 (voltage output, -10 V to +10 V).
 Channel 3 should be set to mode 2 (current output, 0 mA to 20 mA).
 Channels 2 and 4 are out of use.
- 3) Convenient function
 The table output function is used.
- 4) Device assignment

Device	Description	
Input	X000	Start of table output function for channels 1 and 3
	X001	Stop of table output function
	X002	Restart of table output function for channel 3
	D10	Data to be output from channel 1
	D11	Data to be output from channel 2
	D12	Data to be output from channel 3
	D13	Data to be output from channel 4
	D5000 or more	Data table *
Output	Y000	Completion of output of table from channel 1
	Y001	Table output error
	M0	Data table transfer complete
	M1	During output of table from channel 3
	D100	Data table transfer command
	D101	Table output completion flag

* It is necessary to separately create the data table.

→ For a detailed description of creation of the data table, refer to Section 6.2.

2. Example of sequence program

- For FX3U, FX3UC Series PLCs

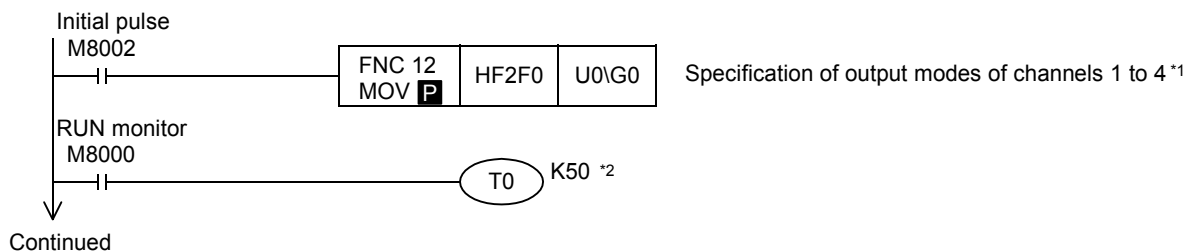

- *1. The output mode setting is retained in the EEPROM of the FX3U-4DA. For this reason, even if the sequence program is deleted, the previously set functions will still be valid.
- *2. After setting the output mode, set the data writing time (waiting time) to 5 seconds or more for each setting. After the output mode is specified, and the same output mode is used, it is not necessary to set the output mode and the waiting time (T0 K50).

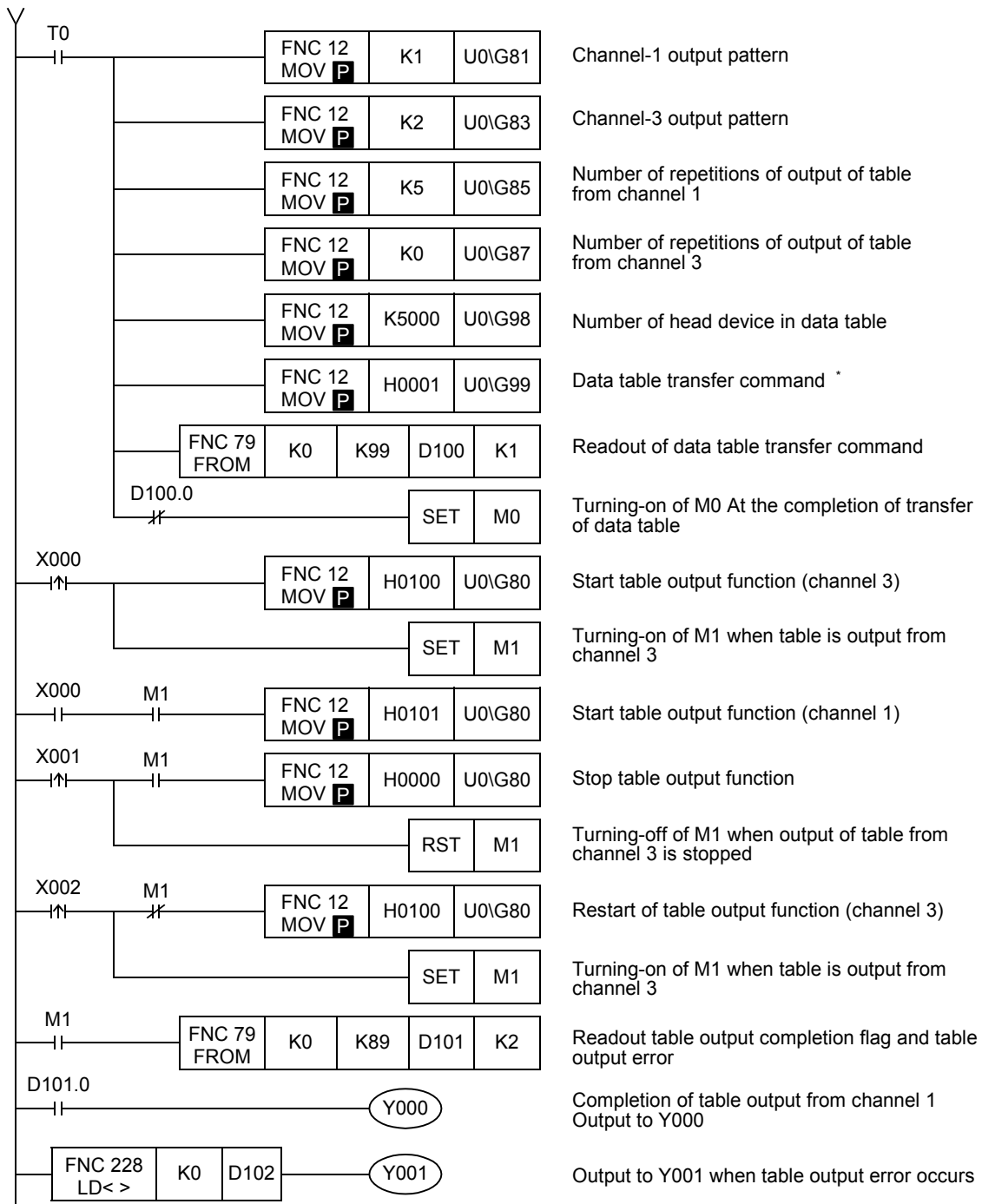

* Execute the data table transfer command as a pulse execution type instruction.

A Common Items
B FX3U-4AD, FX3UC-4AD
C FX3U-4AD-ADP
D FX3G-2AD-BD
E FX3U-4DA
F FX3U-4DA-ADP
G FX3G-1DA-BD
H FX3U-3A-ADP
I FX3U-4AD-PT-ADP
J FX3U-4AD-PTW-ADP

- For FX3G, FX3U, FX3UC Series PLCs

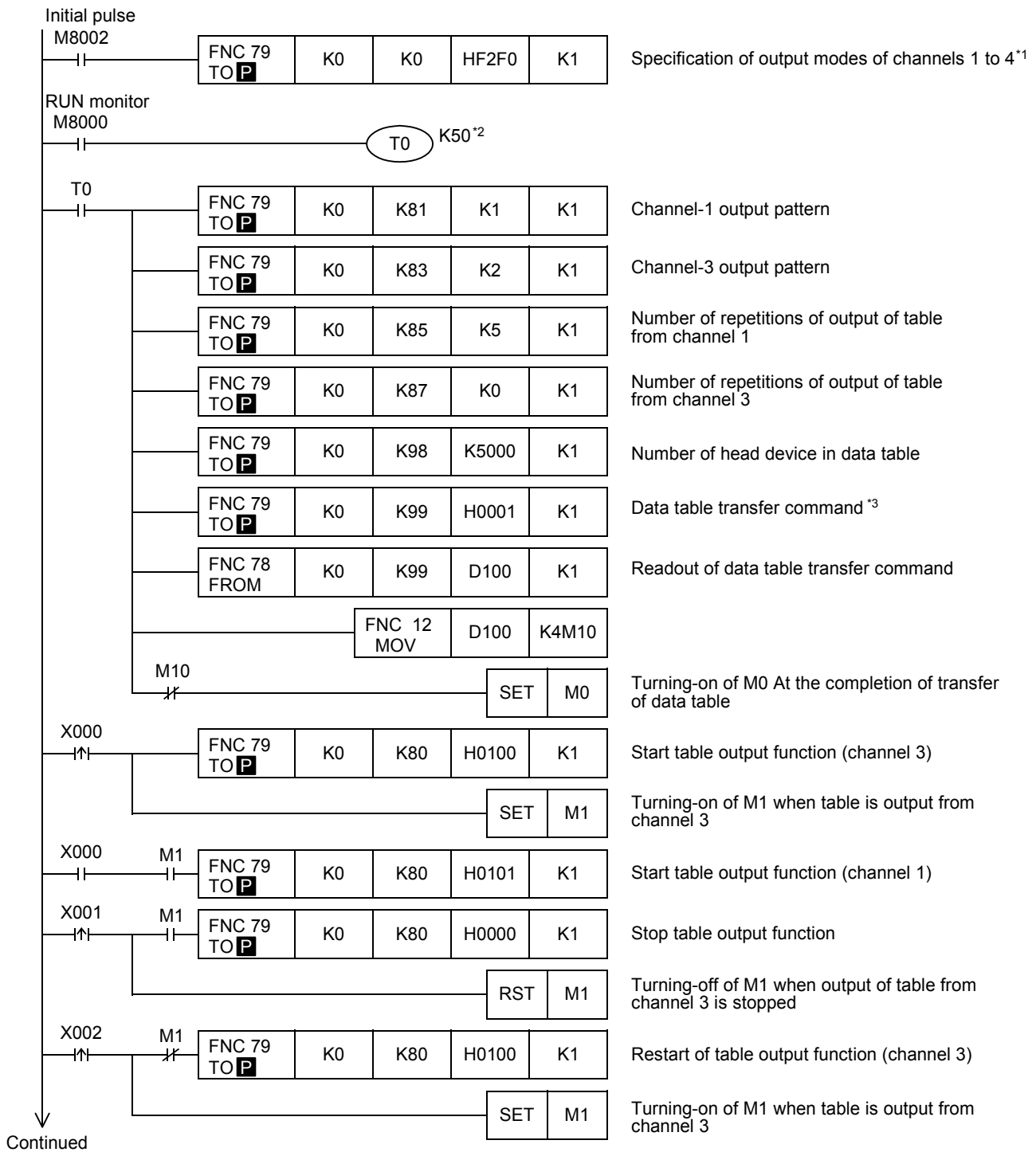

- *1. The output mode setting is retained in the EEPROM of the FX3U-4DA. For this reason, even if the sequence program is deleted, the previously set functions will still be valid.
- *2. After setting the output mode, set the data writing time (waiting time) to 5 seconds or more for each setting. After the output mode is specified, and the same output mode is used, it is not necessary to set the output mode and the waiting time (T0 K50).
- *3. Execute the data table transfer command as a pulse execution type instruction.

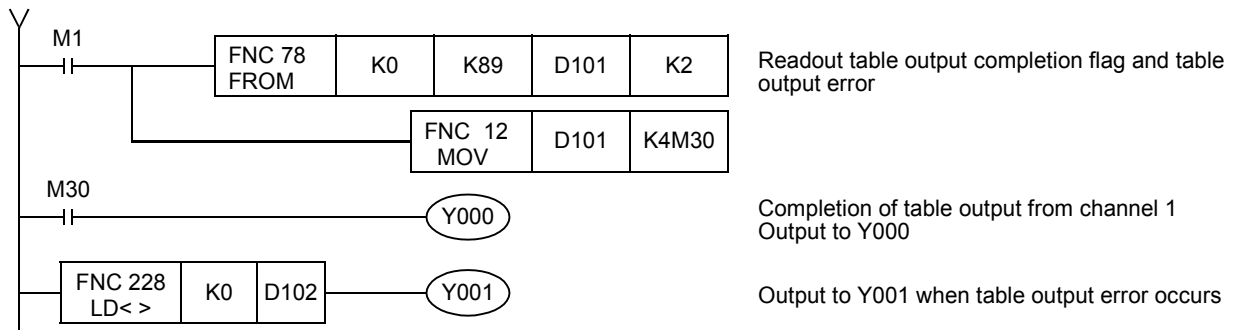

8.4 Program to Initialize FX3U-4DA (Factory Default)

To initialize FX3U-4DA, execute the following program.

This will return the output mode (BFM #0), the offset data (BFM #10 to #13) and the gain data (BFM #14 to #17) will be to the factory default status state.

1. Conditions

The sequence program described in this section is under the following conditions.

- 1) System configuration
 FX3U-4DA (unit No.0) should be connected to the FX3U Series PLC.
- 2) Device assignment

Device	Description
X000	4AD initialization command

2. Example of sequence program

- For FX3U, FX3UC Series PLCs

4DA initialization command

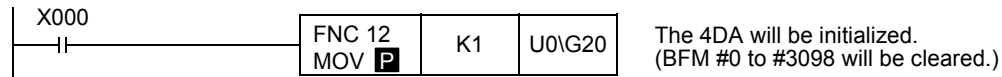

- For FX3G, FX3U, FX3UC Series PLCs

4DA initialization command

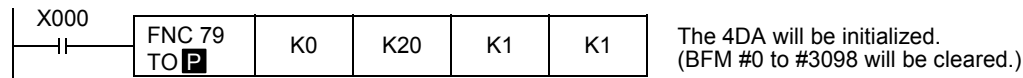

3. Cautions regarding initializing

- During initialization, output is stopped, and H0000 is automatically written in the output status (BFM #6). At the completion of initialization, the output status (BFM #6) will automatically change to H1111, and the output will be restarted.
- It takes approximately 5 seconds to complete initialization. Do not set (write) data in the buffer memory during the period.
- Priority is given to the setting of the change prohibition mode (BFM #19).
- Once initialization is completed, the value in BFM #20 will automatically change to "K0".

9. Troubleshooting

This chapter describes the troubleshooting methods and error codes.

If the D/A conversion data is not output, or if the proper digital value is not output, check the following items:

- Wiring
- Program
- Error status

9.1 PLC Version Number Check

- Any versions (from Ver.2.20 (initial version) to the latest version) of the FX3U Series are compatible.
- Check the version number of FX3UC Series. The version number should be 1.30 or later.
- Any versions (from Ver.1.00 (initial version) to the latest version) of the FX3G Series are compatible.
→ For a detailed description of the version number check method, refer to Section 1.3.

9.2 Wiring Check

Check the wiring as follows:

1. Power

FX3U-4DA needs driving power. Verify that the power supply line is properly connected. Also check that the 24 V indicator lamp of FX3U-4DA is on.

2. Analog output line

Use the 2-core twisted shielded cable for the analog output line. In addition, be sure to separate the analog output line from the other motive power lines or inductive lines.

→ For a detailed description of wiring, refer to Chapter 3.

9.3 Program Check

Check the program as follows:

1. Check the output mode and output data.

Check that data has been set correctly in BFM #0 to #4.

2. Check the settings.

Check that the offset data (BFM #10 to #13), gain data (BFM #14 to #17), upper/lower limit function setting (BFM #38) and table output function start/stop setting (BFM #80) are correct.

9.4 Error Status Check

When an error occurs in FX3U-4DA, the bit appropriate to the error is turned on in the error status (BFM #29). Take measures, referring to the following table.

Bit No.	Items
b0	Error detection
b1	O/G error
b2	Power supply error
b3	Hardware error
b4	-
b5	Error in setting of function for setting output upon PLC stop
b6	Upper/lower limit function setting error
b7	Error in corrective function setting by load resistance (Valid only in voltage output mode)
b8	Table output function setting error
b9	Status automatic transfer setting error
b10	Over-scale
b11	Disconnection detection (Valid only in current output mode)
b12	Setting data change prohibited
b13 to b15	-

1. Error detection (b0)

- 1) Description of error
If any of b1 is turned on, this bit (b11) will turn on.

2. O/G error (b1)

- 1) Description of error
The bit is turned on when the offset or gain data (BFM #10 to #17) in the EEPROM has a setting error.
- 2) Remedy
Check the output mode (BFM #0) and the offset and gain data (BFM #10 to #17).

3. Power supply error (b2)

- 1) Description of error
24 V power is not correctly supplied.
- 2) Remedy
Check the wiring condition or the supply voltage.

4. Hardware error (b3)

- 1) Description of error
FX3U-4DA may be defective.
- 2) Remedy
Please contact the nearest Mitsubishi Electric distributor office.

5. Error when setting the function for output upon PLC stop (b5)

- 1) Description of error
The bit will turn on when the functions setting value for setting output upon PLC stop is not correctly set.
- 2) Remedy
Check the output mode (BFM #0) and the setting value of output data upon PLC stop (BFM #32 to #35).

A
Common Items

B
FX3U-4AD
FX3UC-4AD

C
FX3U-4AD-ADP

D
FX3G-2AD-BD

E
FX3U-4DA

F
FX3U-4DA-ADP

G
FX3G-1DA-BD

H
FX3U-3A-ADP

I
FX3U-4AD-PT-ADP

J
FX3U-4AD-PTW-ADP

6. Upper/lower limit function value setting error (b6)

- 1) Description of error
The bit will turn on when the setting value of the upper/lower limit function is not correctly set.
- 2) Remedy
Check the output mode (BFM #0) and the lower limit (BFM #41 to 44) and upper limit (BFM #45 to #48) settings value of the upper/lower limit function.

7. Error in corrective function setting by load resistance (b7)

- 1) Description of error
The bit will turn on when the setting value of the corrective function by load resistance is not correctly set.
- 2) Remedy
Check the output mode (BFM #0) and the load resistance values (BFM #51 to #54) for the channels.

8. Table output function setting error (b8)

- 1) Description of error
The bit will turn on when the setting value of the table output function is not correctly set.
- 2) Remedy
Check the output mode (BFM #0) and the setting value of the table output function.

9. Status automatic transfer setting error (b9)

- 1) Description of error
The bit will turn on when the setting value of the status automatic transfer function is not correctly set.
- 2) Remedy
Check the setting values in the automatic transfer destination data register specification field (BFM #61 to #63).

10. Over-scale (b10)

- 1) Description of error
This bit will turn on when analog output is out of the specified range.
- 2) Remedy
Check the output mode (BFM #0) setting value and the values in the output data (BFM #1 to #4).

11. Disconnection detection (b11)

- 1) Description of error
The bit is turned on when a cable is disconnected.
- 2) Remedy
Check that no cables are disconnected or have contact failure.

12. Setting data change prohibited (b12)

- 1) Description of error
The bit will turn on while the setting change is prohibited.
- 2) Remedy
To change any setting, set BFM #19 to K3030.

9.5 FX3U-4DA Initialization and Test Program

If the above-mentioned remedies cannot solve the problem, initialize FX3U-4DA and then check the conditions of the FX3U-4DA using the test program.

- For a detailed description of FX3U-4DA initialization program, refer to Subsection 8.4.
- For a detailed description of the test program, refer to Chapter 4.

FX3G/FX3U/FX3UC Series Programmable Controllers

User's Manual [Analog Control Edition] FX3U-4DA-ADP (4-channel analog Output)

Foreword

This manual describes the specifications, wiring, and operation method for the FX3U-4DA-ADP special adapter (4-channel analog output) and should be read and understood before attempting to install or use the unit.

Store this manual in a safe place so that you can take it out and read it whenever necessary. Always forward it to the end user.

This manual confers no industrial property rights or any rights of any other kind, nor does it confer any patent licenses. Mitsubishi Electric Corporation cannot be held responsible for any problems involving industrial property rights which may occur as a result of using the contents noted in this manual.

© 2005 MITSUBISHI ELECTRIC CORPORATION

A
Common Items

B
FX3U-4AD
FX3UC-4AD

C
FX3U-4AD-ADP

D
FX3G-2AD-BD

E
FX3U-4DA

F
FX3U-4DA-ADP

G
FX3G-1DA-BD

H
FX3U-3A-ADP

I
FX3U-4AD-PT
-ADP

J
FX3U-4AD-PTW
-ADP

1. Outline

This chapter outlines the FX3U-4DA-ADP (referred to as 4DA-ADP).

1.1 Outline of Functions

The FX3U-4DA-ADP is an analog special adapter. Which is connectable with the FX3U, FX3UC and FX3G Series PLC to output the voltage/current data for up to 4 channels.

- 1) Up to 4 units of 4DA-ADP can be connected to the FX3U/FX3UC Series PLC.
 Up to 2^{*1} units of 4DA-ADP can be connected to the FX3G Series PLC.
 (Including other analog special adapters).
- 2) Either "voltage output" or "current output" can be specified for each channel.
- 3) The D/A conversion results will be automatically output as the values to the special data register of the FX3U/FX3UC/FX3G Series PLC.

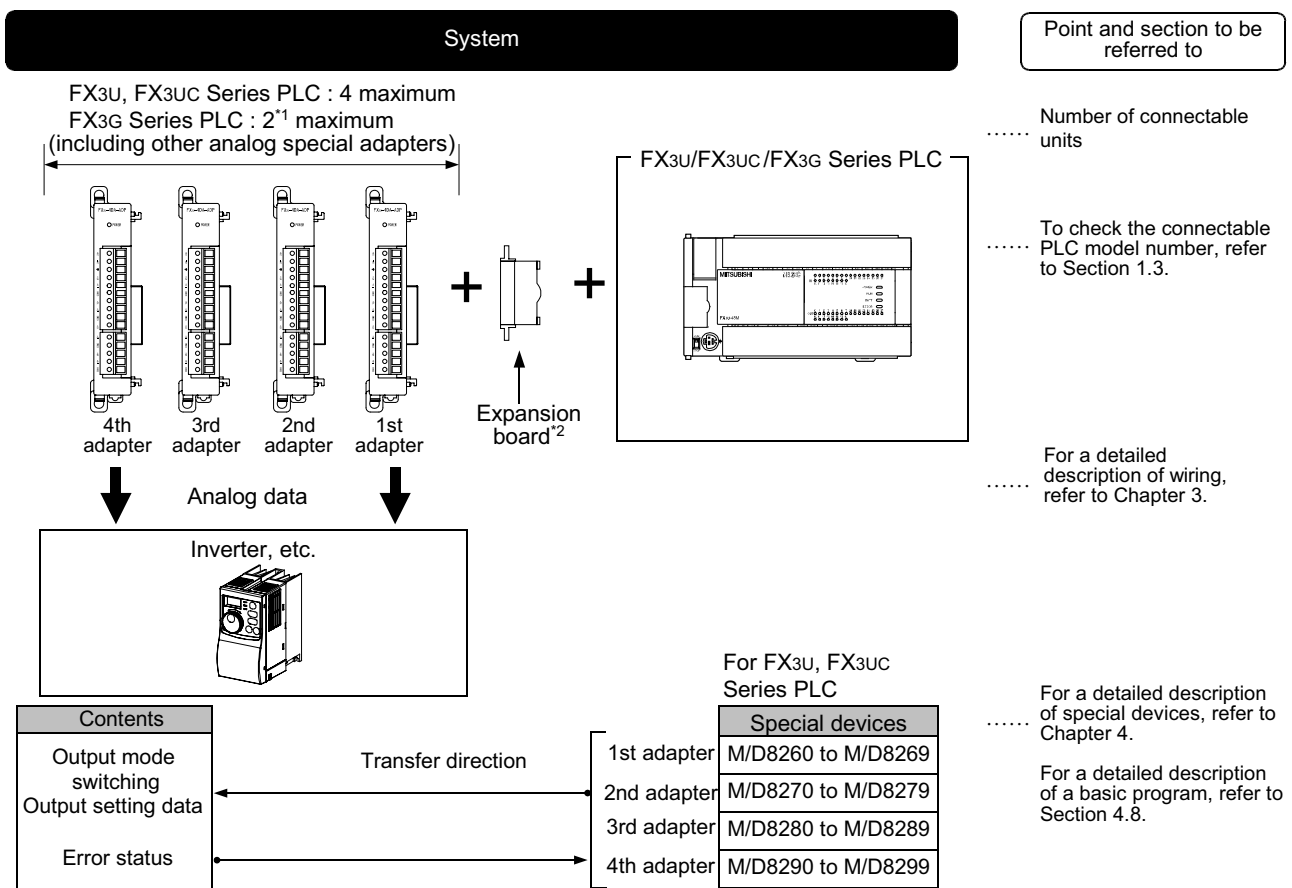

Refer to the system configuration shown in the User's Manual - Hardware Edition to check the number of connectable units and to configure the entire system.

*1. Only 1 analog special adapter can be connected to the FX3G Series PLC(14-point and 24-point type).

*2. The expansion board is not required when connecting with the FX3UC (D, DSS) PLC.

For the FX3G Series PLC a connector conversion adapter is used.

1.2 Setup Procedure Before Starting Operation

Before starting analog output using the 4DA-ADP, follow the procedure below to set up the system:

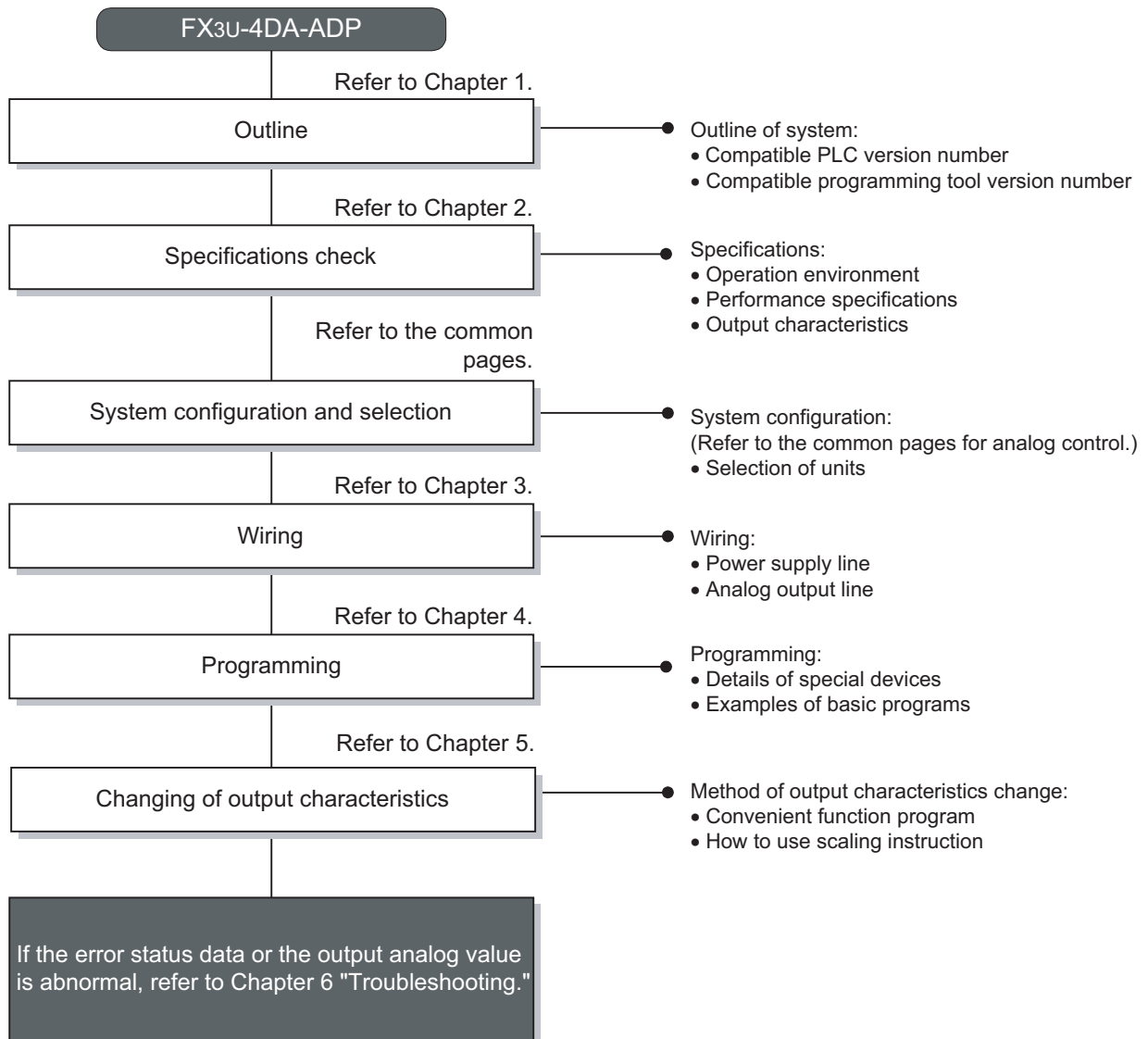

1.3 Connectable PLCs and Version Numbers

The 4DA-ADP is compatible with the following PLCs.

Compatible PLC	Version number	Date of production
FX3U Series PLC	Ver.2.20 or later*1	After May 2005 (initial production)
FX3UC Series PLC	Ver.1.20 or later*1	After April 2004
FX3G Series PLC	Ver.1.00 or later*1	After June 2008 (initial production)

*1. The FX3U/FX3UC Series PLC ver. 2.61 or later and FX3G Series PLC ver. 1.20 or later supports hardware error check.

→ For a detailed description of hardware error, refer to Section 6.5.

1. Version check

Special data register D8001 contains information for determining the PLC version number.

→ For a detailed description of the version check, refer to A. Common Items Subsection 5.1.2.

2. How to check the manufacturer's serial number

The year and month of production of the product can be checked on the nameplate, and on the front of the product.

→ For a detailed description of how to check the manufacturer's serial number, refer to A. Common Items Subsection 5.1.1.

1.4 Compatible Programming Tool Version Number

Use the programming tool with the following version number to create programs for the 4DA-ADP of the FX3U/FX3UC/FX3G Series PLC:

1. GX Works2

Software	Version number	Remarks
GX Works2 SW□DNC-GXW2-J	Ver. 1.07H or later	-
GX Works2 SW□DNC-GXW2-E	Ver. 1.08J or later	-

2. GX Developer

- FX3U/FX3UC Series PLC

Software	Version number	Remarks
GX Developer SW□D5C-GPPW-J	Ver. 8.13P or later	When selecting the model, select FX3U(C)*2.
GX Developer SW□D5C-GPPW-E	Ver. 8.18U or later	

- FX3G Series PLC

Software	Version number	Remarks
GX Developer • SW□D5C-GPPW-J • SW□D5C-GPPW-E	Ver. 8.72A or later	-

If a programming tool with the wrong version number is used, programming will not be possible.

*2. For Ver. 8.13P to 8.24A of GX Developer, select FX3UC for the PLC type.

3. FX-30P

Model name	Version number	Remarks
FX-30P	Ver.1.00 or later	-

2. Specifications

This chapter describes the general, power supply, and performance specifications for 4DA-ADP.

2.1 Generic Specifications

Item	Specifications				
Ambient temperature	0 to 55°C (32 to 131°F) when operating -25 to 75°C (-13 to 167°F) when stored				
Relative humidity	5 to 95%RH (no condensation) when operating				
Vibration resistance*1	DIN Rail Mounting	Frequency (Hz)	Acceleration (m/s ²)	Half amplitude (mm)	10 times of testing in each direction (X-, Y-, and Z-axis directions) (Total: 80 min, each)
		10 - 57	-	0.035	
	Direct Mounting*2	57 - 150	4.9	-	
		10 to 57	-	0.075	
Shock resistance*1	147 m/s ² Acceleration, Action time: 11ms, 3 times by half-sine pulse in each direction X, Y, and Z				
	Noise resistance				
Dielectric withstand voltage	500 V AC, for 1 min		Between all terminals and ground terminal		
Insulation resistance	5MΩ or more using 500V DC insulation resistance meter				
Grounding	Class D grounding (grounding resistance: 100 Ω or less) <Common grounding with a heavy electrical system is not allowed.>*3				
Working environment	Free from corrosive or flammable gas and excessive conductive dusts				
Working altitude	< 2000m*4				

*1. The criterion is shown in IEC61131-2.

*2. If 4DA-ADP is connected to the FX3uc Series PLC, direct installation is not possible.

*3.

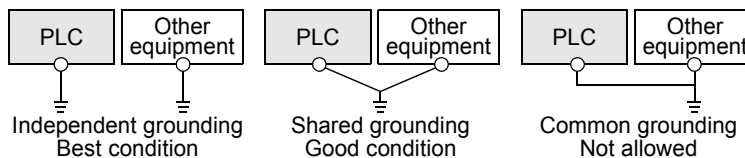

→ For a detailed description of the grounding, refer to Section 3.5.

*4. If the pressure is higher than the atmospheric pressure, do not use 4DA-ADP. The 4DA-ADP may malfunction.

2.2 Power Supply Specifications

Item	Specifications
D/A conversion circuit driving power	24V DC +20%-15%, 150mA (It is necessary to connect a 24V DC power line to the terminal block.)
Interface driving power	5V DC, 15mA (Since the internal power is supplied from the main unit of the FX Series, it is not necessary to supply the power.)

2.3 Performance Specifications

Item	Specifications	
	Voltage output	Current output
Analog output range	0V to 10 V DC (External load: 5kΩ to 1MΩ)	4mA to 20mA DC (External load: 500Ω or less)
Digital input	12 bits, binary	
Resolution	2.5mV(10V/4000)	4μA(16mA/4000)
Total accuracy	<ul style="list-style-type: none"> ±0.5% (±50mV) for 10V full scale (when ambient temperature is 25°C±5 °C) ±1.0% (±100mV) for 10V full scale (when ambient temperature is 0°C to 55°C) If the external load resistance (Rs) is less than 5kΩ, the value calculated from the following formula will be added: (Addition will be 100mV per 1%.) $\frac{47 \times 100}{R_s + 47} - 0.9(\%)$	<ul style="list-style-type: none"> ±0.5% (±80μA) for 16mA full scale (when ambient temperature is 25°C±5°C) ±1.0% (±160μA) for 16mA full scale (when ambient temperature is 0°C to 55 °C)
D/A conversion time	<ul style="list-style-type: none"> FX3U/FX3UC Series PLC : 200μs (The data will be updated at every scan time.) FX3G Series PLC : 250μs (The data will be updated at every scan time.) → For a detailed description of data update, refer to Section 2.4.	
Output characteristics		
Insulation method	<ul style="list-style-type: none"> The photocoupler is used to insulate the analog output area from the PLC. The DC/DC converter is used to insulate the power supply line from the analog output area. Channels are not insulated from each other. 	
Numbers of I/O points occupied	0 point (This number is not related to the maximum number of input/output points of the PLC.)	

2.4 D/A Conversion Time

This section describes the D/A conversion time.

2.4.1 When connected to a FX3U, FX3UC PLC

1. D/A conversion and special data register update timing

D/A conversion is performed at every scan time of the PLC.

During execution of the END instruction, the PLC writes the output setting data of the special data registers, performs D/A conversion of the data, and updates the analog output data.

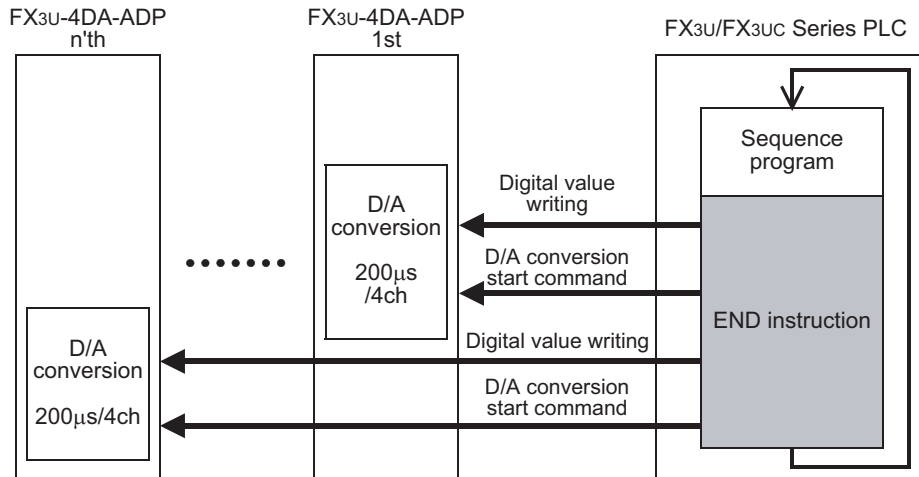

2. D/A conversion during PLC stop

If the output holding function cancellation setting is disabled by the special device, the offset value will be output.

If the output holding function cancellation setting is enabled, the output at switching from RUN to STOP will be latched.

Just after power-on, however, the offset value will be output until operation begins.

3. If two or more analog special adapters are connected

During execution of the END instruction, data in all the connected adapters will be subject to D/A conversion and then output (in the order of 1st adapter → 2nd adapter... 4th adapter).

4. D/A conversion speed (data update time)

During execution of END instruction, the output setting digital data per of 4 channel will be subject to D/A conversion which takes 200µs, after which the analog data will be output.

END instruction execution time will be "200µs × number of connected adapters."

2.4.2 When connected to a FX3G PLC

1. D/A conversion and special data register update timing

D/A conversion is performed at every scan time of the PLC.

During execution of the END instruction, the PLC writes the output setting data of the special data registers, performs D/A conversion of the data, and updates the analog output data.

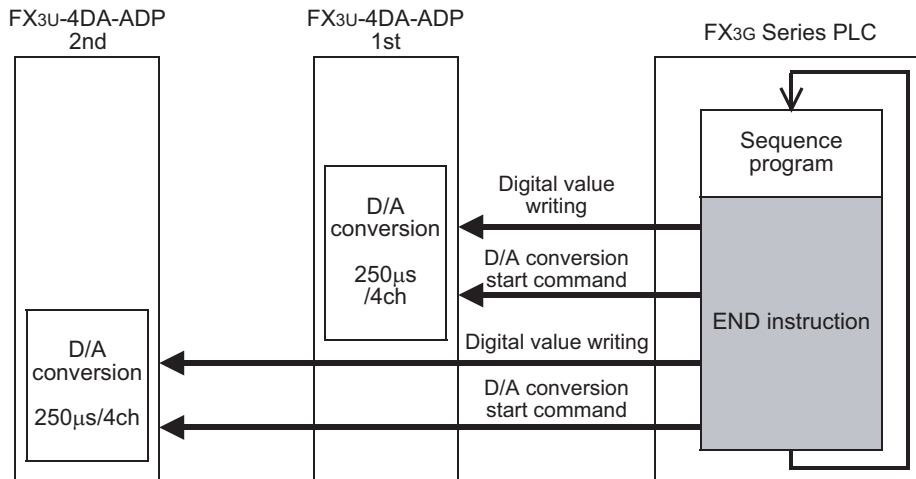

2. D/A conversion during PLC stop

If the output holding function cancellation setting is disabled by the special device, the offset value will be output.

If the output holding function cancellation setting is enabled, the output at switching from RUN to STOP will be latched.

Just after power-on, however, the offset value will be output until operation begins.

3. If two analog special adapters are connected

During execution of the END instruction, data in all the connected adapters will be subject to D/A conversion and then output (in the order of 1st adapter → 2nd adapter).

4. D/A conversion speed (data update time)

During execution of END instruction, the output setting digital data per of 4 channel will be subject to D/A conversion which takes 250µs, after which the analog data will be output.

END instruction execution time will be "250µs × number of connected adapters."

3. Wiring

This chapter describes the 4DA-ADP wiring.
Observe the following caution to wire the 4DA-ADP.

WIRING PRECAUTIONS



DANGER

- Make sure to cut off all phases of the power supply externally before attempting wiring work. Failure to do so may cause electric shock or damages to the product.

WIRING PRECAUTIONS



CAUTION

- Connect the DC power supply wiring to the dedicated terminals described in this manual. If an AC power supply is connected to a DC input/output terminal or DC power supply terminal, the PLC will be burnt out.
- Do not wire vacant terminals externally. Doing so may damage the product.
- Perform class D grounding (grounding resistance: 100Ω or less) to the grounding terminal on the main unit. Do not use common grounding with heavy electrical systems.
- When drilling screw holes or wiring, make sure cutting or wire debris does not enter the ventilation slits. Failure to do so may cause fire, equipment failures or malfunctions.
- Make sure to observe the following precautions in order to prevent malfunctions under the influence of noise:
 - Do not bundle the power line or twisted shielded cable together with or lay it close to the main circuit, high-voltage line, or load line. Otherwise, noise disturbance and/or surge induction are likely to take place. As a guideline, lay the control line at least 100mm (3.94") or more away from the main circuit, high-voltage line, or load line.
 - Ground the shield of the analog input/output cable at one point on the signal receiving side. However, do not use common grounding with heavy electrical systems.
- Make sure to properly wire to the European terminal board in accordance with the following precautions. Failure to do so may cause electric shock, equipment failures, a short-circuit, wire breakage, malfunctions, or damage to the product.
 - The disposal size of the cable end should follow the dimensions described in the manual.
 - Tightening torque should follow the specifications in the manual.
 - Twist the end of strand wire and make sure there are no loose wires.
 - Do not solder-plate the electric wire ends.
 - Do not connect more than the specified number of wires or electric wires of unspecified size.
 - Affix the electric wires so that neither the terminal block nor the connected parts are directly stressed.

3.1 Terminal Layout

The terminals of the 4DA-ADP are arranged as follows:

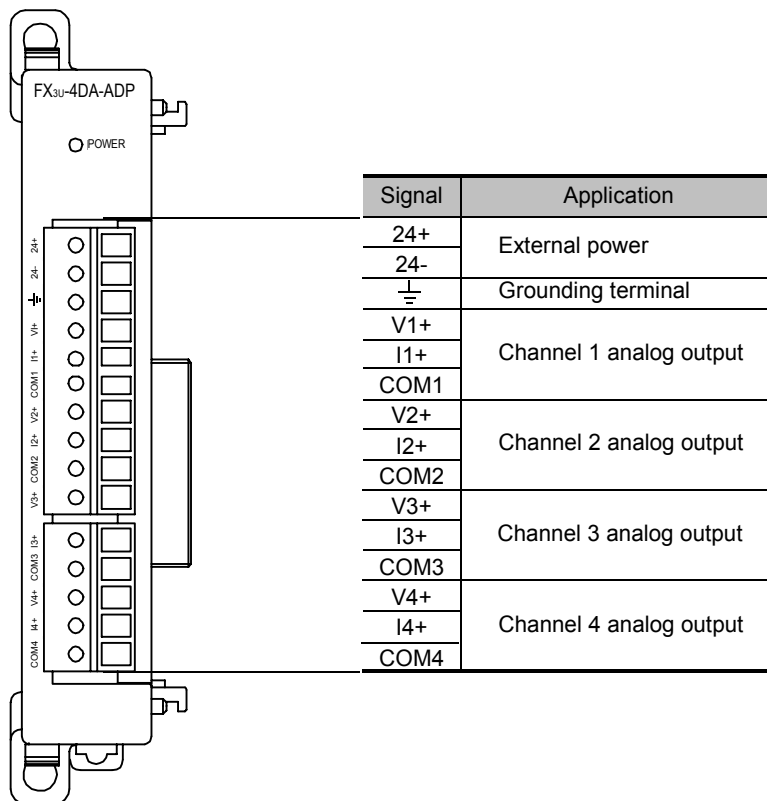

A
Common Items

B
FX3U-4AD
FX3UC-4AD

C
FX3U-4AD-ADP

D
FX3G-2AD-BD

E
FX3U-4DA

F
FX3U-4DA-ADP

G
FX3G-1DA-BD

H
FX3U-3A-ADP

I
FX3U-4AD-PT
-ADP

J
FX3U-4AD-PTW
-ADP

3.2 Applicable Cables and Terminal Tightening Torque

Use the following cables to connect with the counterpart equipment. Terminate the cable end as shown below.

1. Cable

Applicable cable and tightening torque

	Wire size (stranded/ single-wire)	Tightening torque	Termination
Single-wire	0.3mm ² to 0.5mm ² (AWG22 to 20)	0.22N•m to 0.25N•m	<ul style="list-style-type: none"> To connect a stranded cable, peel the cover off the cable and then twist the core before connection. To connect a single-wire cable, just peel the cover off the cable before connection.
2-wire	0.3mm ² (AWG22)		
Rod terminal with insulation sleeve	0.3mm ² to 0.5mm ² (AWG22 to 20) (Refer to the rod terminal external view shown in the following figure.)		<ul style="list-style-type: none"> Rod terminal with insulation sleeve (recommended terminal) AI 0.5-8WH : Manufactured by Phoenix Contact Caulking tool CRIMPFOX 6*1 : Manufactured by Phoenix Contact (or CRIMPFOX 6T-F*2 : Manufactured by Phoenix Contact)

- *1. Old model name : CRIMPFOX ZA 3
- *2. Old model name : CRIMPFOX UD 6

2. Termination of cable end

To terminate the cable, treat the stranded/single wire directly or use a rod terminal with insulation sleeve.

- To directly terminate the end of a stranded/single-wire cable:
 - Twist the end of the stranded cable so that the "barbed wires" cannot protrude.
 - Do not solder-plate the end of the cable.
- To terminate cable end using a rod terminal with insulation sleeve:
 If the cable cover is too thick, it may be difficult to insert the cable into the insulation sleeve. For this reason, select an appropriate cable while referring to the external view.
 <Reference>

Termination of cable end

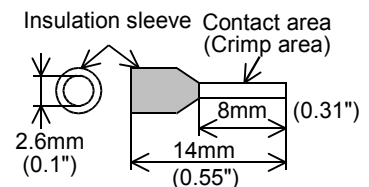
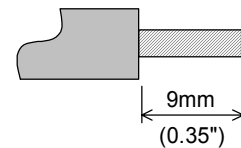

Manufacturer	Model	Caulking tool
Phoenix Contact	AI 0.5-8WH	CRIMPFOX 6*3 (or CRIMPFOX 6T-F*4)

- *3. Old model name : CRIMPFOX ZA 3
- *4. Old model name : CRIMPFOX UD 6

3. Tool

- To tighten terminals, use a small-sized screwdriver whose head is straight and is not widened as shown in the figure to the right.

Note:

If the diameter of screwdriver grip is too small, tightening torque will not be able to be achieved. To achieve the appropriate tightening torque shown in the table above, use the following screwdriver or an appropriate replacement (grip diameter: approximately 25mm (0.98")).
 <Reference>

Manufacturer	Model
Phoenix Contact	SZS 0.4×2.5

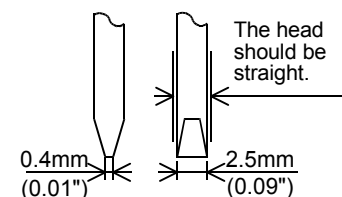

3.3 Power Supply Line

Connect the 24V DC power supply line of the 4DA-ADP to the 24+ and 24- terminals of the terminal block.

3.3.1 To connect to the FX3G, FX3U Series PLC

1. To use an External power supply

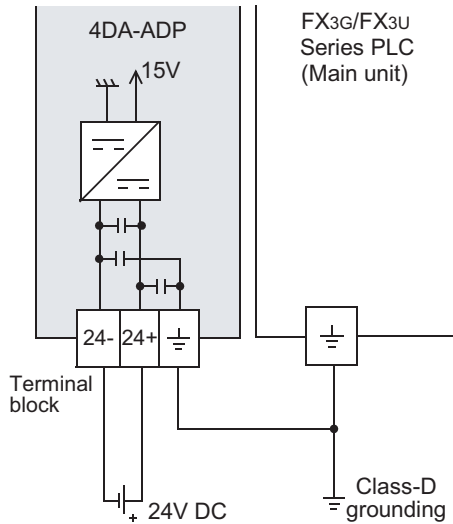

2. To use the 24V DC power of the PLC

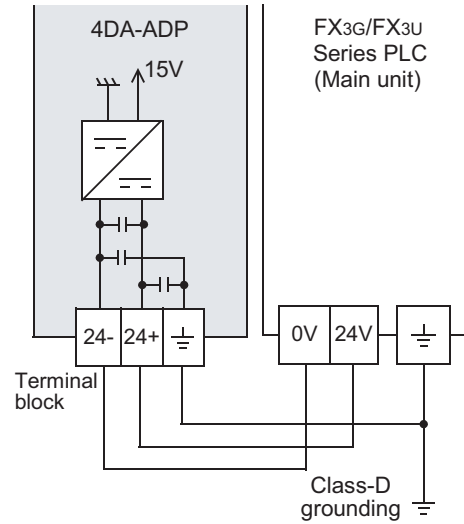

Caution regarding connection of the power supply line:

- Ground the " \perp " terminal to class-D grounded power supply line (100Ω or less) together with the grounding terminal of the PLC main unit.
- When using an external power supply, turn it ON at the same time with the main unit or earlier than the main unit. When turning OFF the power, confirm the safety of the system, and then turn OFF the power of the PLC (including special adapter) at the same time.

3.3.2 To connect to the FX3uc Series PLC

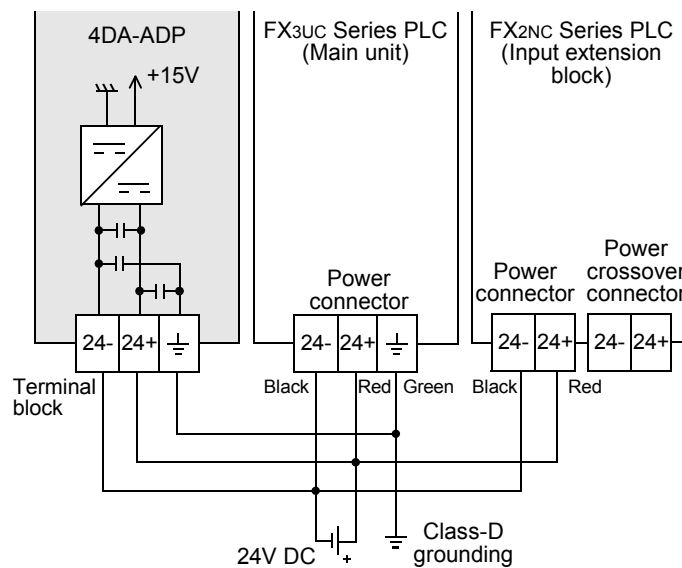

Caution regarding connection of the power supply line:

- For the 24V DC power supply line, be sure to use the same power as the FX3uc Series PLC.
- Ground the " \perp " terminal to a class-D grounded power supply line (100Ω or less) together with the grounding terminal of the PLC main unit.

3.4 Analog Output Line

The analog output type, "voltage output" or "current output", can be selected for each channel.

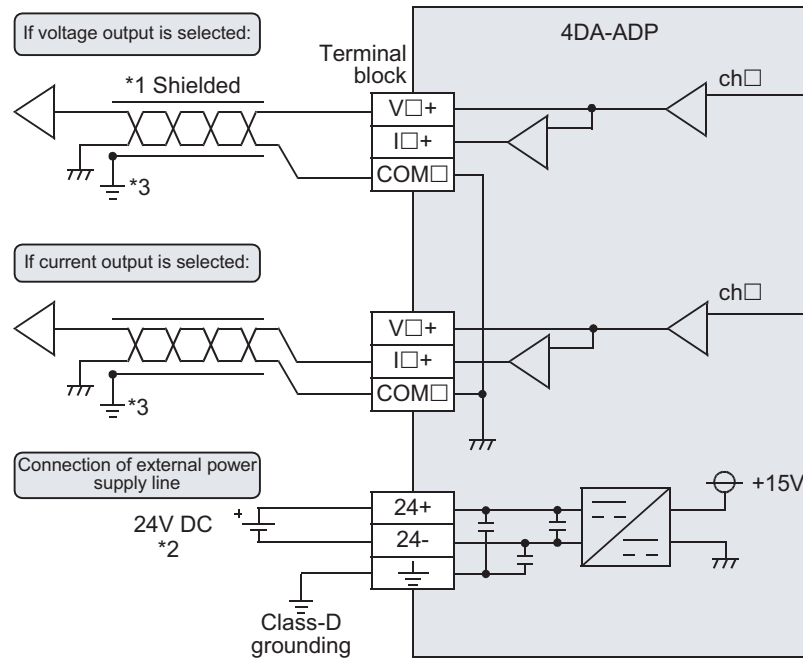

V□+, I□+, ch□: □ represents the channel number.

- *1. Use 2-core shielded twisted pair cable for the analog output lines, and separate the analog output lines from other power lines or inductive lines.
- *2. 24V DC service power supply of the FX3G/FX3U Series PLC can also be used.
- *3. Ground the shielded wire at one point on the signal receiving side.

3.5 Grounding

Grounding should be performed as stated below.

- The grounding resistance should be 100Ω or less.
- Independent grounding should be performed for best results.
 When independent grounding is not performed, perform "shared grounding" as shown in the following figure.

→ For details, refer to User's Manual - Hardware Edition of the PLC Series.

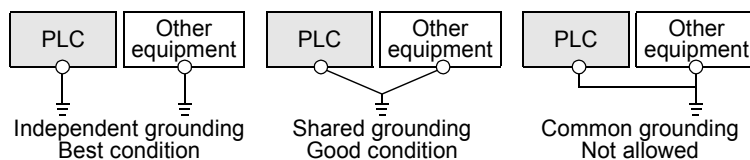

- The grounding wire size should be AWG22 to 20 (0.3 to 0.5 mm²).
- The grounding point should be close to the PLC, and all grounding wires should be as short as possible.

4. Programming

This chapter describes how to create programs that can output the analog data using the 4DA-ADP.

4.1 Writing of D/A Conversion Data

- 1) The input digital data will be converted into analog data and then output to the terminals.
 - 2) If data is stored in the special devices, the averaging time can be set, and the output mode can be specified.
 - 3) Special auxiliary relays (10 points) and special data registers (10 points) are assigned automatically starting from the adapter nearest the main unit.
 → For a detailed description of special device assignment, refer to Section 4.2.
- FX3U, FX3UC Series PLC

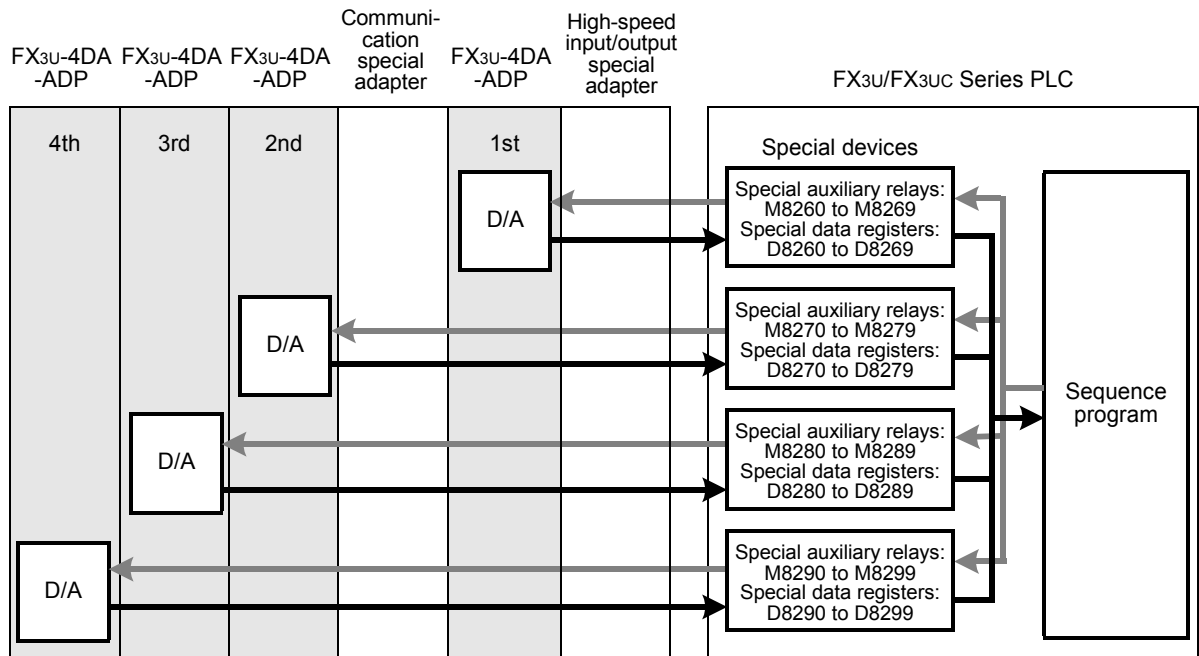

The analog special adapter nearest to the main unit is counted as the 1st analog special adapter, and the next adapter as the 2nd analog special adapter, and so on. In this case, however, do not include the high-speed input/output special adapter, communication special adapter, and the CF card special adapter.

- FX3G Series PLC

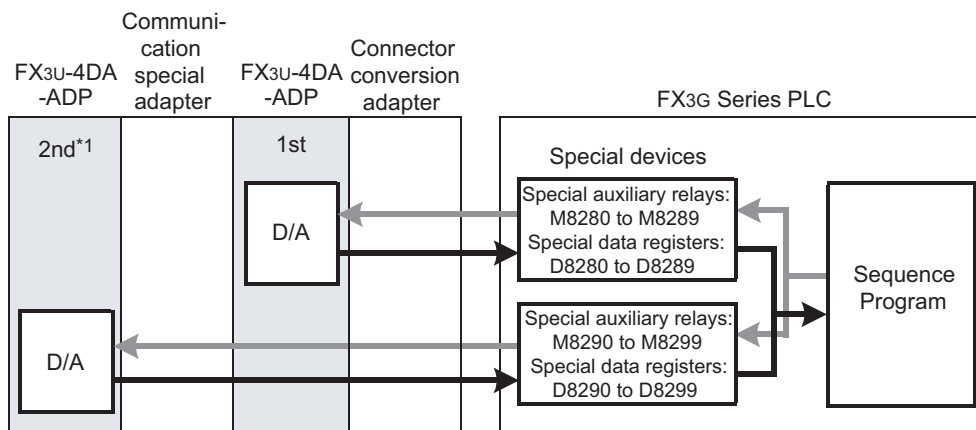

The analog special adapter nearest to the main unit is counted as the 1st analog special adapter, and the next adapter as the 2nd analog special adapter. In this case, however, do not include the connector conversion adapter and the communication special adapter.

*1. The second special adapter is not available in the FX3G Series PLC(14-point and 24-point type).

4.2 List of Special Devices

If 4DA-ADP is connected, special devices will be assigned automatically as shown in the following table:

- FX3U, FX3UC Series PLC

R: Read / W: Write

Special device	Device number				Description	Attribute	Reference	
	1st	2nd	3rd	4th				
Special auxiliary relay	M8260	M8270	M8280	M8290	Switches the output mode of channel 1.	R/W	Section 4.3	
	M8261	M8271	M8281	M8291	Switches the output mode of channel 2.	R/W		
	M8262	M8272	M8282	M8292	Switches the output mode of channel 3.	R/W		
	M8263	M8273	M8283	M8293	Switches the output mode of channel 4.	R/W		
	M8264	M8274	M8284	M8294	Sets the cancel of the channel-1 output holding function.	R/W	Section 4.4	
	M8265	M8275	M8285	M8295	Sets the cancel of the channel-2 output holding function.	R/W		
	M8266	M8276	M8286	M8296	Sets the cancel of the channel-3 output holding function.	R/W		
	M8267	M8277	M8287	M8297	Sets the cancel of the channel-4 output holding function.	R/W		
		M8268 to M8269	M8278 to M8279	M8288 to M8289	M8298 to M8299	Unused (Do not use.)	-	-
Special data register	D8260	D8270	D8280	D8290	Channel-1 output setting data	R/W	Section 4.5	
	D8261	D8271	D8281	D8291	Channel-2 output setting data	R/W		
	D8262	D8272	D8282	D8292	Channel-3 output setting data	R/W		
	D8263	D8273	D8283	D8293	Channel-4 output setting data	R/W		
		D8264 to D8267	D8274 to D8277	D8284 to D8287	D8294 to D8297	Unused (Do not use.)	-	-
		D8268	D8278	D8288	D8298	Error status	R/W	Section 4.6
		D8269	D8279	D8289	D8299	Model code = 2	R	Section 4.7

- FX3G Series PLC

R: Read / W: Write

Special device	Device number		Description	Attribute	Reference
	1st	2nd			
Special auxiliary relay	M8280	M8290	Switches the output mode of channel 1.	R/W	Section 4.3
	M8281	M8291	Switches the output mode of channel 2.	R/W	
	M8282	M8292	Switches the output mode of channel 3.	R/W	
	M8283	M8293	Switches the output mode of channel 4.	R/W	
	M8284	M8294	Sets the cancel of the channel-1 output holding function.	R/W	Section 4.4
	M8285	M8295	Sets the cancel of the channel-2 output holding function.	R/W	
	M8286	M8296	Sets the cancel of the channel-3 output holding function.	R/W	
	M8287	M8297	Sets the cancel of the channel-4 output holding function.	R/W	
	M8288 to M8289	M8298 to M8299	Unused (Do not use.)	-	-
Special data register	D8280	D8290	Channel-1 output setting data	R/W	Section 4.5
	D8281	D8291	Channel-2 output setting data	R/W	
	D8282	D8292	Channel-3 output setting data	R/W	
	D8283	D8293	Channel-4 output setting data	R/W	
	D8284 to D8287	D8294 to D8297	Unused (Do not use.)	-	-
	D8288	D8298	Error status	R/W	Section 4.6
	D8289	D8299	Model code = 2	R	Section 4.7

4.3 Switching of Output Mode

Turn the special auxiliary relay on/off to switch the output mode of 4DA-ADP between the current output mode and the voltage output mode.

To switch the output mode, use the following special auxiliary relays:

- FX3U, FX3UC Series PLC

Special auxiliary relay				Description	
1st	2nd	3rd	4th		
M8260	M8270	M8280	M8290	Switches the output mode of channel 1	OFF:Voltage output ON :Current output
M8261	M8271	M8281	M8291	Switches the output mode of channel 2	
M8262	M8272	M8282	M8292	Switches the output mode of channel 3	
M8263	M8273	M8283	M8293	Switches the output mode of channel 4	

- FX3G Series PLC

Special auxiliary relay		Description	
1st	2nd		
M8280	M8290	Switches the output mode of channel 1	OFF:Voltage output ON :Current output
M8281	M8291	Switches the output mode of channel 2	
M8282	M8292	Switches the output mode of channel 3	
M8283	M8293	Switches the output mode of channel 4	

1. Program Example (For FX3U, FX3UC Series PLC)

To switch the output mode of a channel, create a sequence program as follows:

- 1) To switch the channel output mode of channel 1 of the 1st analog special adapter to the voltage output mode:

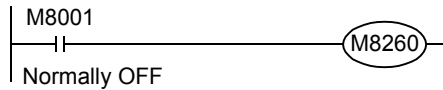

- 2) To switch the output mode of channel 2 of the 1st analog special adapter to the current output mode:

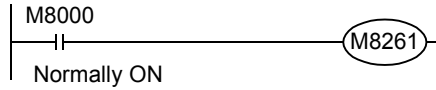

4.4 Output Holding Function Cancellation Setting

This setting can hold the analog data output or to output the offset data (0V for voltage output mode, 4mA for current output mode) when the PLC stops.

To cancel or set the output holding function, use the following special auxiliary relays:

- FX3U, FX3UC Series PLC

Special auxiliary relay				Description
1st	2nd	3rd	4th	
M8264	M8274	M8284	M8294	Cancel output holding function setting for channel 1
M8265	M8275	M8285	M8295	Cancel output holding function setting for channel 2
M8266	M8276	M8286	M8296	Cancel output holding function setting for channel 3
M8267	M8277	M8287	M8297	Cancel output holding function setting for channel 4

OFF: Holds the analog data output just before stop of the PLC.
 ON: Outputs the offset data at stop of the PLC.

- FX3G Series PLC

Special auxiliary relay		Description
1st	2nd	
M8284	M8294	Cancel output holding function setting for channel 1
M8285	M8295	Cancel output holding function setting for channel 2
M8286	M8296	Cancel output holding function setting for channel 3
M8287	M8297	Cancel output holding function setting for channel 4

OFF: Holds the analog data output just before stop of the PLC.
 ON: Outputs the offset data at stop of the PLC.

1. Program Example (For FX3U, FX3UC Series PLC)

To set or cancel the output holding function for a channel, create a sequence program as follows:

- 1) To set the output holding function for channel 1 of the 1st analog special adapter:

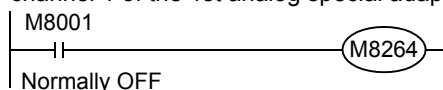

- 2) To cancel the output holding function for channel 2 of the 1st analog special adapter:

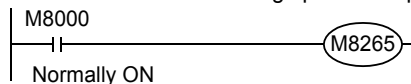

4.5 Output Setting Data

Numeric data type: Decimal (K)

The 4DA-ADP performs D/A conversion on the output setting data (digital data) into analog data, and outputs the analog data.

Use the special data registers shown in the following table for the output setting data:

- FX3U, FX3UC Series PLC

Special data register				Description
1st	2nd	3rd	4th	
D8260	D8270	D8280	D8290	Channel-1 output setting data
D8261	D8271	D8281	D8291	Channel-2 output setting data
D8262	D8272	D8282	D8292	Channel-3 output setting data
D8263	D8273	D8283	D8293	Channel-4 output setting data

- FX3G Series PLC

Special data register		Description
1st	2nd	
D8280	D8290	Channel-1 output setting data
D8281	D8291	Channel-2 output setting data
D8282	D8292	Channel-3 output setting data
D8283	D8293	Channel-4 output setting data

1. Program Example (For FX3U, FX3UC Series PLC)

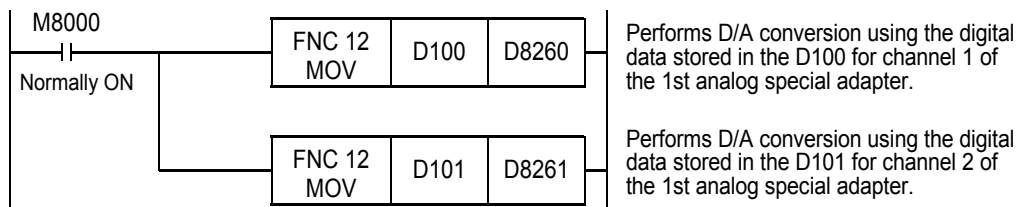

Using the indicator or the sequence program, input the digital data to be subject to D/A conversion (to be output as analog data) in D100 and D101.

4.6 Error Status

1. Description of setting

If an error is detected on 4DA-ADP, the error status data will be stored in the corresponding special data register.

The following table shows the special data registers that store the error status data:

- FX3U, FX3UC Series PLC

Special data register				Description
1st	2nd	3rd	4th	
D8268	D8278	D8288	D8298	Stores the error status data.

- FX3G Series PLC

Special data register		Description
1st	2nd	
D8288	D8298	Stores the error status data.

Check the ON/OFF status of each bit of the error status data register to check the description of the error. Errors are assigned to the bits as shown in the following table. Create a program to detect errors.

Bit	Description
b0	Channel-1 output data setting error
b1	Channel-2 output data setting error
b2	Channel-3 output data setting error
b3	Channel-4 output data setting error
b4	EEPROM error
b5	Unused
b6	4DA-ADP hardware error (Power supply error included)*1
b7 to b15	Unused

- *1. The 4DA-ADP is supported from June, 2009 and later.
 For using the 4DA-ADP, it is necessary to use a main unit whose version supports this function.
 For the applicability of each combination of 4DA-ADP and main unit, refer to Section 6.5.

2. Program Example 1 (For FX3G, FX3U, FX3UC Series PLC)

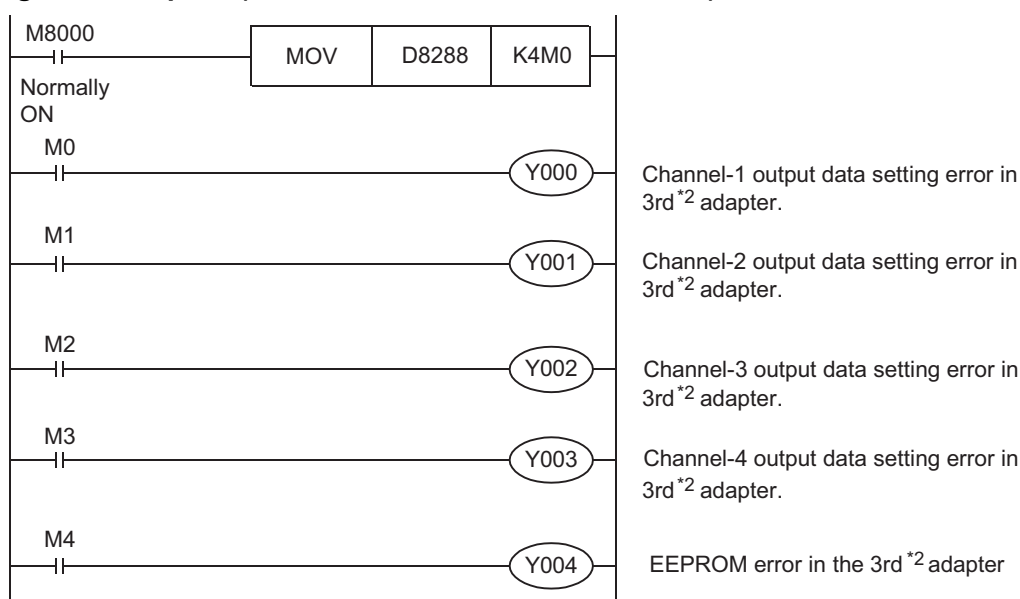

- *2. "1st" for the FX3G PLC.

3. Program Example 2 (For FX3U, FX3UC Series PLC)

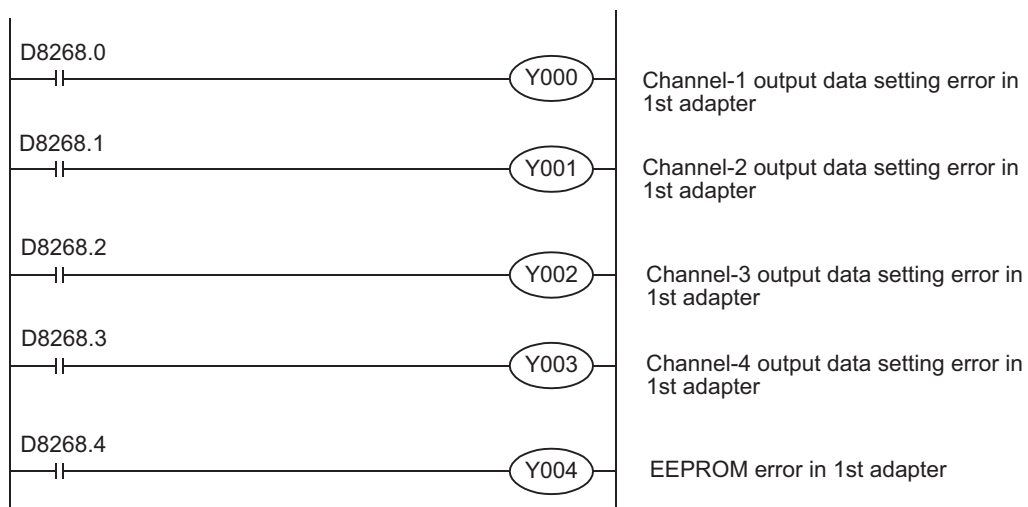

4.7 Model Code

Initial value: K2
 Numeric data type: Decimal (K)

1. Description of setting

When the 4DA-ADP is connected, model code "2" is stored in the corresponding special data register. The following table shows the special data registers that store the model code:

- FX3U, FX3UC Series PLC

1st	2nd	3rd	4th	Description
D8269	D8279	D8289	D8299	Model code

- FX3G Series PLC

1st	2nd	Description
D8289	D8299	Model code

Use the special data registers above to check whether 4DA-ADP is connected or not.

2. Program Example (For FX3U, FX3UC Series PLC)

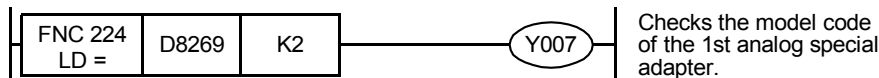

4.8 Basic Program Example

Create the following basic program example to output D/A converted analog data.

- For FX3G, FX3U, FX3UC Series PLC

The following program will set channel 1 of the 3rd^{*1} adapter to the voltage output mode and channel 2 to current output mode, and will set digital data in D100 and D101 for D/A conversion.

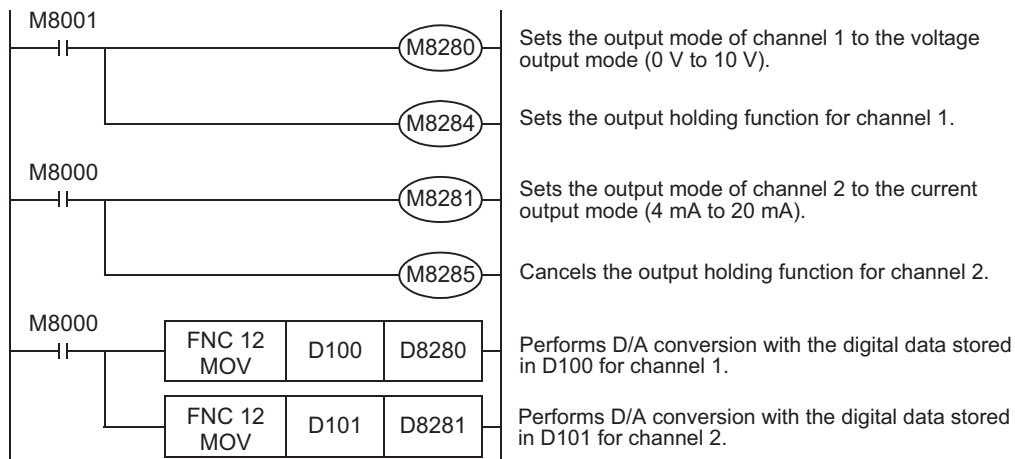

Using the indicator or the sequence program, input the digital data to be subject to D/A conversion (to be output as analog data) in D100 and D101.

*1. "1st" for the FX3G PLC.

5. Changing of Output Characteristics

Use the scaling instruction (SCL/FNC 259) for the FX3U/FX3UC Series PLC to change the output characteristics.

FX3G Series PLCs do not support the scaling instruction. Use sequence programs to change the output characteristics.

→ For a detailed description of scaling instruction, refer to the **FX3G/FX3U/FX3UC Series Programming Manual - Basic & Applied Instruction**.

5.1 Example: Changing of Voltage Output Characteristics

This section describes an example of a program that can change the digital value range from 400 to 2000 (when analog output range is 1 to 5V) to 0 to 10000.

A specified digital value is inputted into D100.

1. Output characteristics

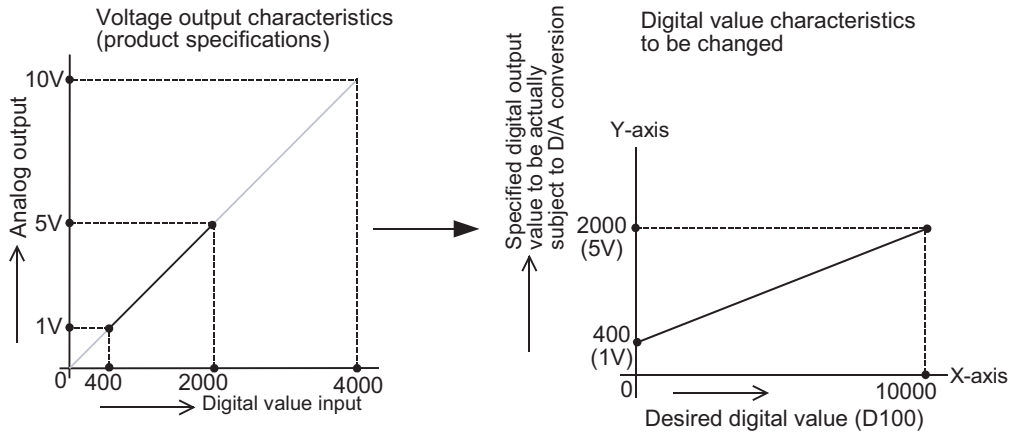

2. Example of program 1 (For FX3u, FX3uc Series PLC)

- For example, create the following program to change the digital output of the 1st analog special adapter.

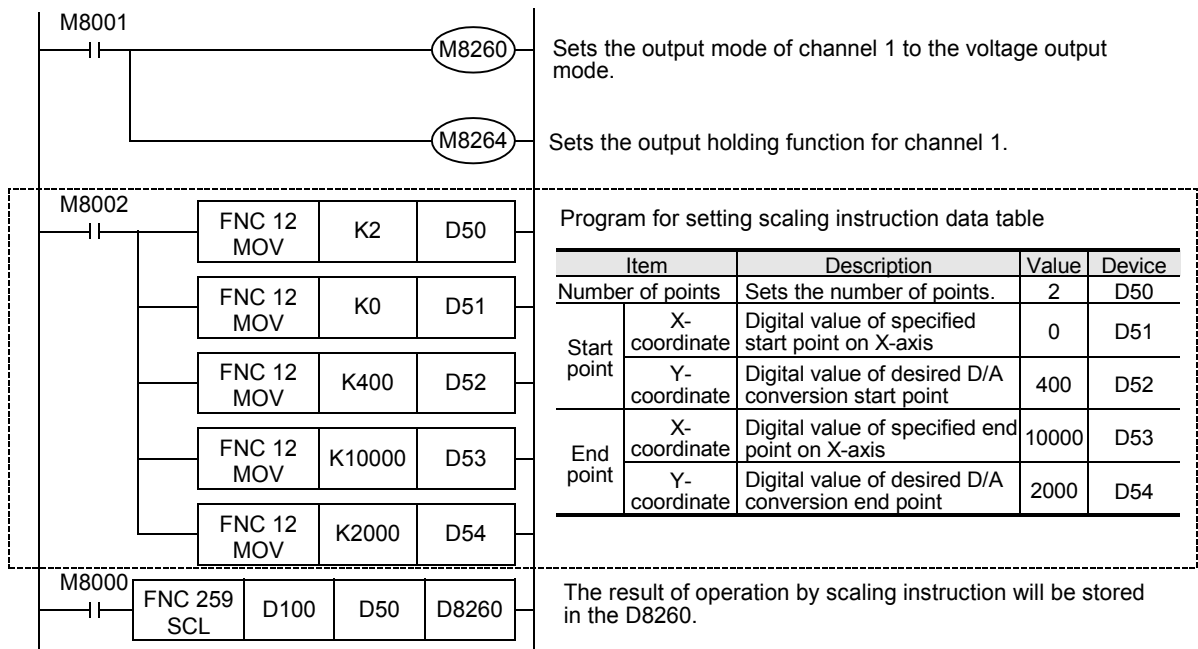

3. Example of program 2 (For FX3G Series PLC)

- For example, create the following program to change the digital output data (D100) of the 1st analog special adapter.

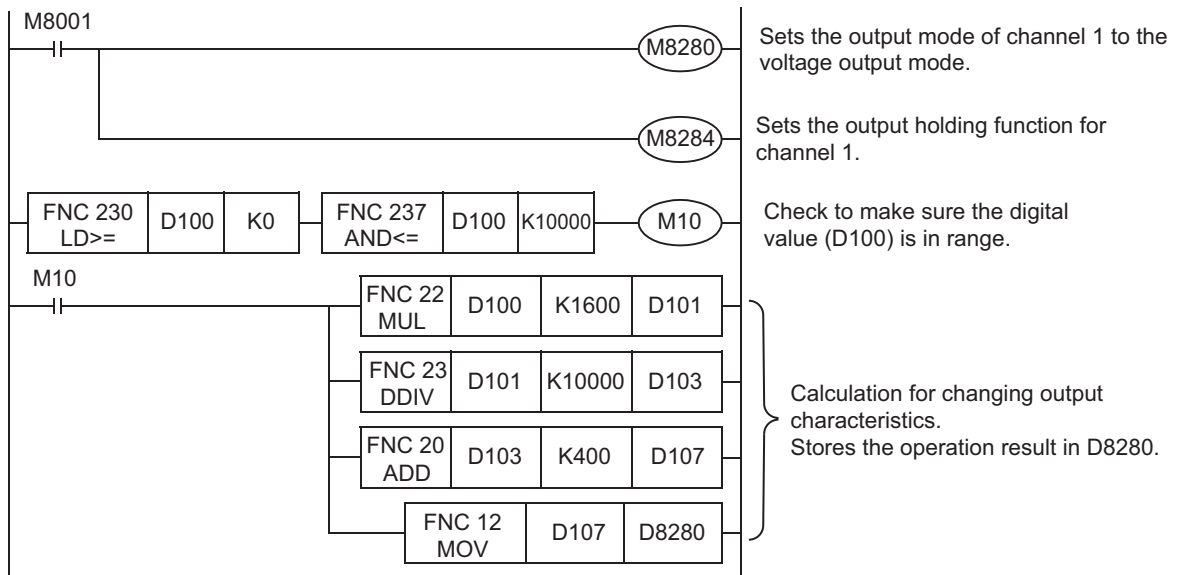

4. Cautions regarding programming

- GX Developer version 8.13P or later supports scaling instruction (SCL/FNC259).
- If the input digital value for the D/A conversion is out of the data table range specified by scaling instruction (SCL/FNC259), the FX Series PLC will detect an operation error (error code: K6706).

6. Troubleshooting

This chapter describes the troubleshooting methods and error status.

If analog data is not output, or if the proper analog value is not output, check the following items:

- Version number of PLC
- Wiring
- Special devices
- Programs
- Error status

6.1 PLC Version Number Check

- Any versions (from Ver.2.20 (initial version) to the latest version) of the FX3U Series are compatible.
- Check the version number of FX3UC Series. The version number should be 1.20 or later.
- Any versions (from Ver.1.00 (initial version) to the latest version) of the FX3G Series are compatible.
→ **For a detailed description of the version number check method, refer to Section 1.3.**

6.2 Wiring Check

Check the following items for wiring:

1. Power

The 4DA-ADP needs driving power. Verify that the power supply line is properly connected. Also check that the POWER indicator lamp of the 4DA-ADP is on.

2. Analog output line

Use the 2-core twisted shielded pair cable for the analog output line. In addition, be sure to separate the analog output line from other power lines or inductive lines.

→ **For a detailed description of wiring, refer to Chapter 3.**

6.3 Special Device Check

Check whether the special devices for the 4DA-ADP are being used correctly:

1. Output mode switching

Verify that the special device for switching the output mode is correctly set.

Turn off the device to set the output mode to the voltage output mode. Turn on the device to set the output mode to the current output mode.

2. Output setting data

Check that the special device of the selected channel is correctly selected. This special device should be selected depending on the connected position and the channel.

3. Error status

Check that no error is detected in the 4DA-ADP.

If an error is detected, check the details of the error, and then check the wiring and programs.

→ **For a detailed description of special devices, refer to Chapter 4.**

6.4 Program Check

Check the following items for the program:

1. Device for setting specified digital value

Check that different values are not written to this device using other programs.

6.5 Error Status Check

If an error occurs in the 4DA-ADP, the corresponding bit will turn on.

The bit which is turned ON due to the error status is held ON until overwritten to OFF by the program or the power is cycled.

Bit	Description
b0	Channel-1 output data setting error
b1	Channel-2 output data setting error
b2	Channel-3 output data setting error
b3	Channel-4 output data setting error
b4	EEPROM error
b5	Unused
b6	4DA-ADP hardware error (Power supply error included)*1
b7 to b15	Unused

*1. The 4DA-ADP is supported from June, 2009 and later.

For using the 4DA-ADP, it is necessary to use a main unit whose version supports this function. For the applicability of each combination of 4DA-ADP and main unit, refer to the table below.

4DA-ADP year and month of production	FX3U, FX3UC Series PLC		FX3G Series PLC	
	Former than Ver.2.60	Ver.2.61 or later	Former than Ver.1.10	Ver.1.20 or later
Former than 2009 May	Not applicable	Not applicable	Not applicable	Not applicable
2009 June or later	Not applicable	Applicable	Not applicable	Applicable

For confirmation of the version of the main unit and checking the 4DA-ADP serial number, refer to the following.

→ For details of confirmation of the PLC main unit version, refer to A. Common Items Subsection 5.1.2.

→ For details of check of the 4DA-ADP serial number, refer to A. Common Items Subsection 5.2.1.

To solve the problem, refer to the troubleshooting method described below:

1. Output data setting error (b0 to b3)

- 1) Description of error
The specified digital value is outside the specified range.
Analog data will not be correctly output.
- 2) Remedy
Check that the specified digital value is within the specified range.

2. EEPROM error (b4)

- 1) Description of error
The adjustment data set in the EEPROM before delivery from our factory cannot be read out properly or is destroyed.
- 2) Remedy
Please contact the nearest Mitsubishi Electric distributor office.

3. 4DA-ADP hardware error (b6)

- 1) Description of error
The 4DA-ADP is not operating properly.
- 2) Remedy
Check that the 24V DC power is properly supplied to the 4DA-ADP. Also check that the 4DA-ADP is correctly connected to the PLC.
If the problem cannot be solved even after the above check, please contact the nearest Mitsubishi Electric distributor office.

FX3G/FX3U/FX3UC Series Programmable Controllers

User's Manual [Analog Control Edition] FX3G-1DA-BD (1-channel analog Output)

Foreword

This manual describes the specifications, wiring, and operation method for the FX3G-1DA-BD analog output expansion board (1-channel analog output) and should be read and understood before attempting to install or use the unit.

Store this manual in a safe place so that you can take it out and read it whenever necessary. Always forward it to the end user.

This manual confers no industrial property rights or any rights of any other kind, nor does it confer any patent licenses. Mitsubishi Electric Corporation cannot be held responsible for any problems involving industrial property rights which may occur as a result of using the contents noted in this manual.

© 2005 MITSUBISHI ELECTRIC CORPORATION

A
Common Items

B
FX3U-4AD
FX3UC-4AD

C
FX3U-4AD-ADP

D
FX3G-2AD-BD

E
FX3U-4DA

F
FX3U-4DA-ADP

G
FX3G-1DA-BD

H
FX3U-3A-ADP

I
FX3U-4AD-PT
-ADP

J
FX3U-4AD-PTW
-ADP

1. Outline

This chapter outlines the FX3G-1DA-BD (referred to as 1DA-BD).

1.1 Outline of Functions

The FX3G-1DA-BD is an analog expansion board. Which is connectable with the FX3G Series PLC to output the voltage/current data for up to 1 channel.

- 1) Up to 2^{*1} units of 1DA-BD can be connected to the FX3G Series PLC.
 (Including other analog expansion boards, analog special adapters).
- 2) Either "voltage output" or "current output" can be specified.
- 3) The D/A conversion results will be automatically output as the values to the special data register of the FX3G Series PLC.

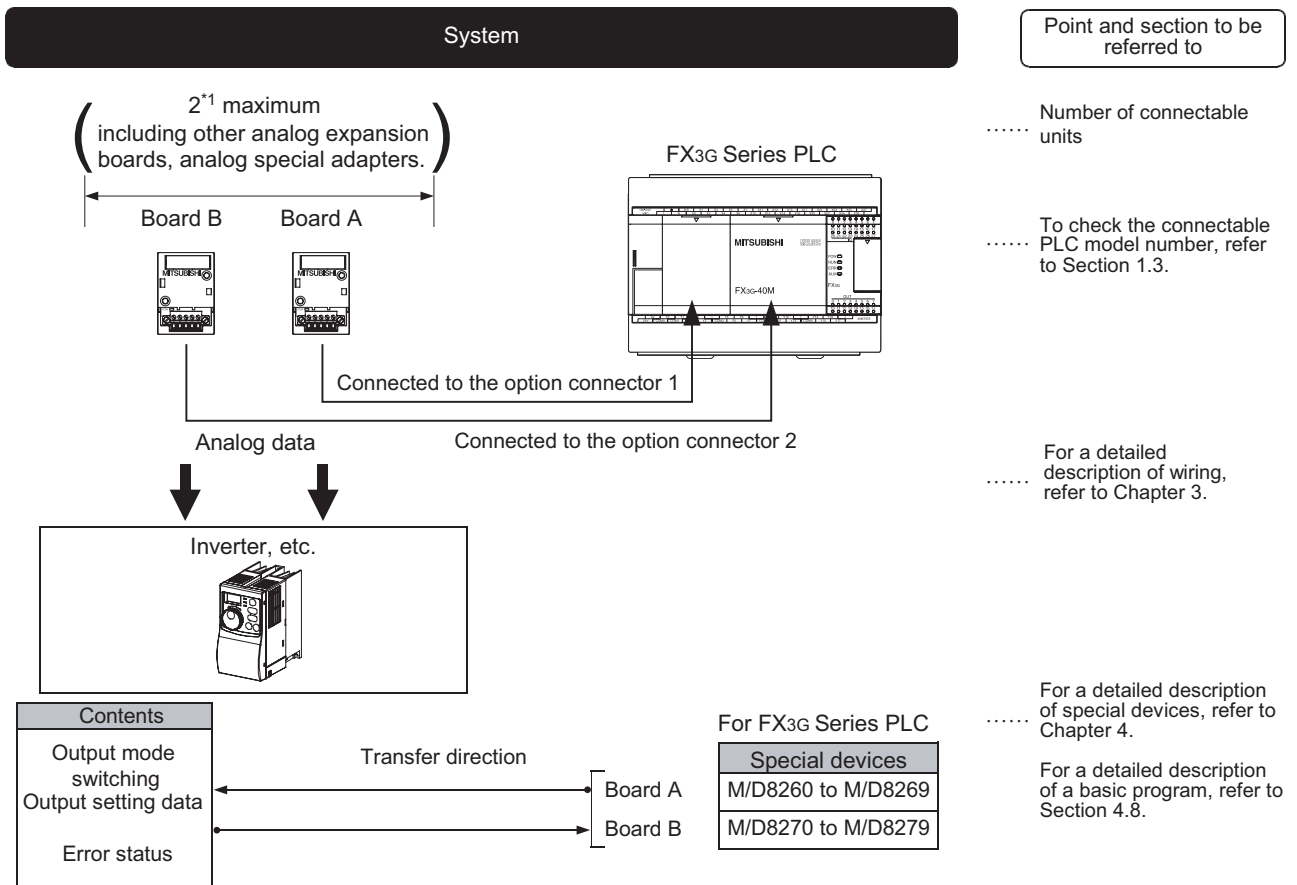

Refer to the system configuration shown in the User's Manual - Hardware Edition to check the number of connectable units and to configure the entire system.

*1. Only 1 analog board can be connected to the FX3G Series PLC(14-point and 24-point type).

1.2 Setup Procedure Before Starting Operation

Before starting analog output using the 1DA-BD, follow the procedure below to set up the system:

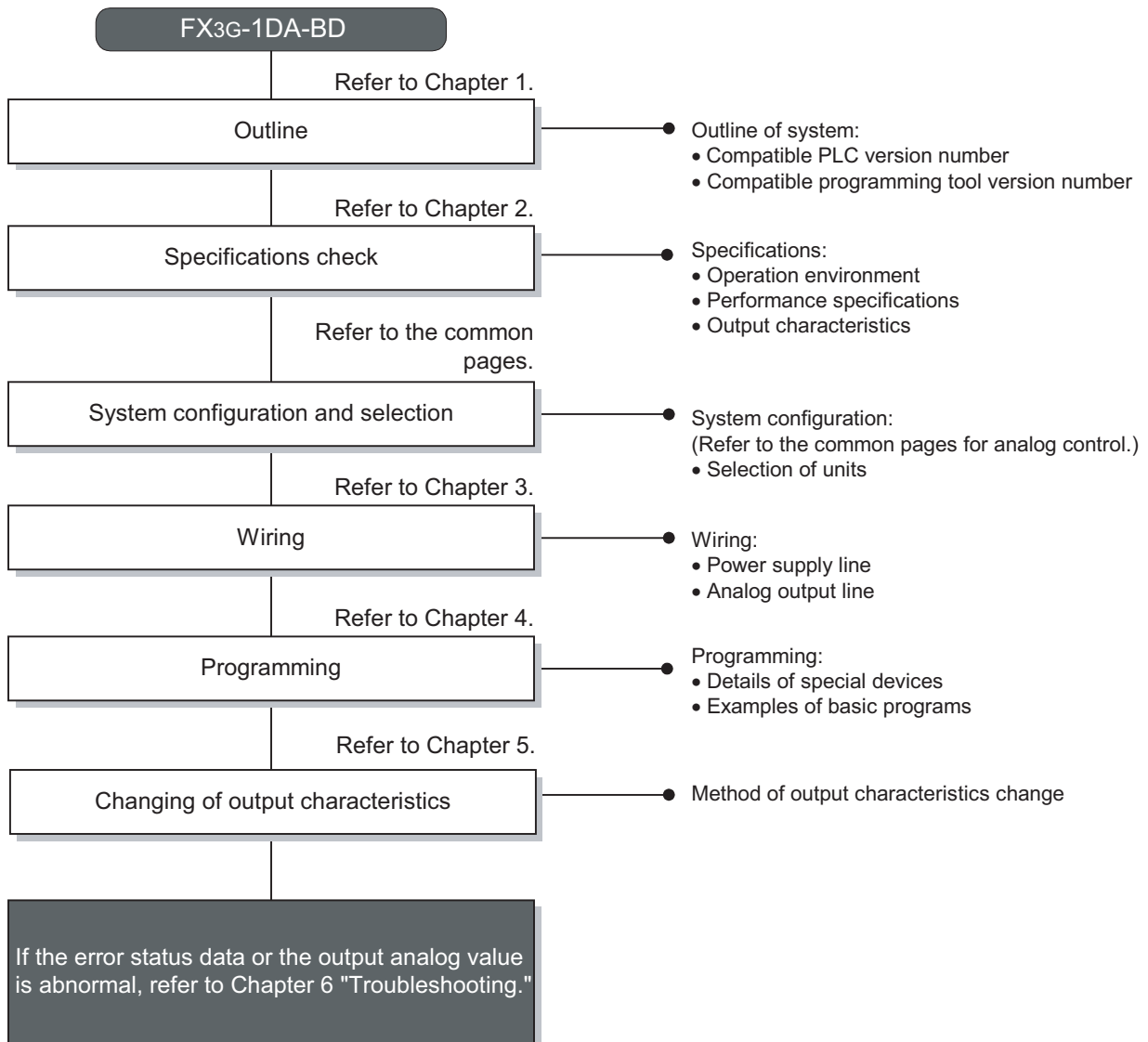

1.3 Connectable PLCs and Version Numbers

The 1DA-BD is compatible with the following PLC.

Compatible PLC	Version number	Date of production
FX3G Series PLC	Ver.1.10 or later	After October 2008 (initial production)

1. Version check

Special data register D8001 contains information for determining the PLC version number.

→ For a detailed description of the version check, refer to A.Common Items Subsection 5.1.2.

2. How to check the manufacturer's serial number

The year and month of production of the product can be checked on the nameplate, and on the front of the product.

→ For a detailed description of how to check the manufacturer's serial number, refer to A.Common Items Subsection 5.1.1.

1.4 Compatible Programming Tool Version Number

Use the programming tool with the following version number to create programs for the 1DA-BD of the FX3G Series PLC:

1. GX Works2

Software	Version number	Remarks
GX Works2 SW□DNC-GXW2-J	Ver. 1.07H or later	-
GX Works2 SW□DNC-GXW2-E	Ver. 1.08J or later	-

2. GX Developer

Software	Version number	Remarks
GX Developer • SW□D5C-GPPW-J • SW□D5C-GPPW-E	Ver. 8.72A or later	-

If a programming tool with the wrong version number is used, programming will not be possible.

3. FX-30P

Model name	Version number	Remarks
FX-30P	Ver. 1.00 or later	-

A
Common Items

B
FX3U-4AD
FX3UC-4AD

C
FX3U-4AD-ADP

D
FX3G-2AD-BD

E
FX3U-4DA

F
FX3U-4DA-ADP

G
FX3G-1DA-BD

H
FX3U-3A-ADP

I
FX3U-4AD-PT
-ADP

J
FX3U-4AD-PTW
-ADP

2. Specifications

This chapter describes the general and performance specifications for 1DA-BD.

2.1 Generic Specifications

Item	Specifications				
Ambient temperature	0 to 55°C (32 to 131°F) when operating -25 to 75°C (-13 to 167°F) when stored				
Relative humidity	5 to 95%RH (no condensation) when operating				
Vibration resistance *1	DIN Rail Mounting	Frequency (Hz)	Acceleration (m/s ²)	Half amplitude (mm)	10 times of testing in each direction (X-, Y-, and Z-axis directions) (Total: 80 min, each)
		10 - 57	-	0.035	
	Direct Mounting	57 - 150	4.9	-	
		10 to 57	-	0.075	
57 to 150	9.8	-			
Shock resistance *1	147 m/s ² Acceleration, Action time: 11ms, 3 times by half-sine pulse in each direction X, Y, and Z				
Noise resistance	Using noise simulator of: Noise voltage: 1,000Vp-p / Noise width: 1μs / Rise: 1ns / Cycle: 30 to 100Hz				
Grounding	Class D grounding (grounding resistance: 100 Ω or less) <Common grounding with a heavy electrical system is not allowed.>*2				
Working environment	Free from corrosive or flammable gas and excessive conductive dusts				
Working altitude	< 2000m ^{*3}				

*1. The criterion is shown in IEC61131-2.

*2.

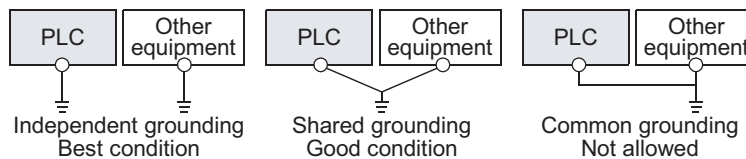

→ For a detailed description of the grounding, refer to Section 3.5.

*3. If the pressure is higher than the atmospheric pressure, do not use 1DA-BD.
 The 1DA-BD may malfunction.

2.2 Performance Specifications

Item	Specifications	
	Voltage output	Current output
Analog output range	0V to 10 V DC (External load: 2kΩ to 1MΩ)	4mA to 20mA DC (External load: 500Ω or less)
Digital input	12 bits, binary	11 bits, binary
Resolution	2.5mV(10V/4000)	8μA(16mA/2000)
Total accuracy	<ul style="list-style-type: none"> ±0.5% (±50mV) for 10V full scale (when ambient temperature is 25°C±5 °C) ±1.0% (±100mV) for 10V full scale (when ambient temperature is 0°C to 55°C) Shipment adjustment is carried out by external load resistance 2kΩ. If external load resistance becomes larger than 2kΩ, the output voltage will increase slightly. When the load is 1MΩ, the output voltage becomes about 2% higher than the correct value.	<ul style="list-style-type: none"> ±0.5% (±80μA) for 16mA full scale (when ambient temperature is 25°C±5°C) ±1.0% (±160μA) for 16mA full scale (when ambient temperature is 0°C to 55 °C)
D/A conversion time	60μs (The data will be updated at every scan time.) → For a detailed description of data update, refer to Section 2.4.	
Output characteristics	<p>Caution: An area of dead band is located in the region of 0V. Therefore the output analog value may not represent the digital value accurately.</p>	
Insulation method	<ul style="list-style-type: none"> The analog output area is not insulated from the PLC. 	
Numbers of I/O points occupied	0 point (This number is not related to the maximum number of input/output points of the PLC.)	

A
Common Items

B
FX3U-4AD
FX3UC-4AD

C
FX3U-4AD-ADP

D
FX3G-2AD-BD

E
FX3U-4DA

F
FX3U-4DA-ADP

G
FX3G-1DA-BD

H
FX3U-3A-ADP

I
FX3U-4AD-PT-ADP

J
FX3U-4AD-PTW-ADP

2.3 D/A Conversion Time

This section describes the D/A conversion time.

1. D/A conversion and special data register update timing

D/A conversion is performed at every scan time of the PLC.

During execution of the END instruction, the PLC writes the output setting data of the special data registers, performs D/A conversion of the data, and updates the analog output data.

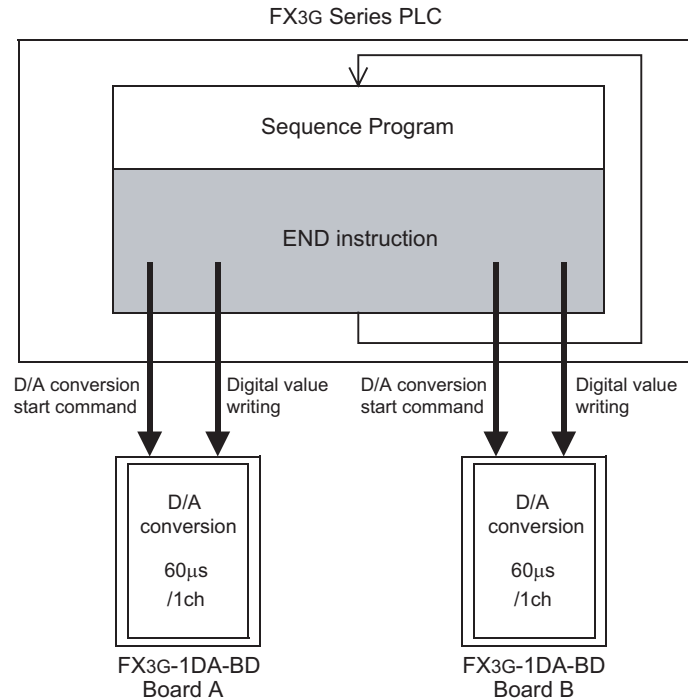

2. D/A conversion during PLC stop

If the output holding function cancellation setting is disabled by the special device, the offset value will be output.

If the output holding function cancellation setting is enabled, the output at switching from RUN to STOP will be latched.

Just after power-on, however, the offset value will be output until operation begins.

3. If two analog expansion boards are connected

During execution of the END instruction, data in all the connected boards will be subject to D/A conversion and then output (in the order of board A → board B).

4. D/A conversion speed (data update time)

During execution of END instruction, the output setting digital data will be subject to D/A conversion which takes 60µs, after which the analog data will be output.

END instruction execution time will be "60µs × number of connected board."

3. Wiring

This chapter describes the 1DA-BD wiring.
 Observe the following caution to wire the 1DA-BD.

WIRING PRECAUTIONS



- Make sure to cut off all phases of the power supply externally before attempting wiring work. Failure to do so may cause electric shock or damages to the product.

WIRING PRECAUTIONS



- Connect the DC power supply wiring to the dedicated terminals described in this manual. If an AC power supply is connected to a DC input/output terminal or DC power supply terminal, the PLC will be burnt out.
- Do not wire vacant terminals externally. Doing so may damage the product.
- Perform class D grounding (grounding resistance: 100Ω or less) to the grounding terminal on the main unit. Do not use common grounding with heavy electrical systems.
- When drilling screw holes or wiring, make sure cutting or wire debris does not enter the ventilation slits. Failure to do so may cause fire, equipment failures or malfunctions.
- Make sure to observe the following precautions in order to prevent malfunctions under the influence of noise:
 - Do not bundle the power line or twisted shielded cable together with or lay it close to the main circuit, high-voltage line, or load line. Otherwise, noise disturbance and/or surge induction are likely to take place. As a guideline, lay the control line at least 100mm (3.94") or more away from the main circuit, high-voltage line, or load line.
 - Ground the shield of the analog input/output cable at one point on the signal receiving side. However, do not use common grounding with heavy electrical systems.
- Make sure to properly wire to the European terminal board in accordance with the following precautions. Failure to do so may cause electric shock, equipment failures, a short-circuit, wire breakage, malfunctions, or damage to the product.
 - The disposal size of the cable end should follow the dimensions described in the manual.
 - Tightening torque should follow the specifications in the manual.
 - Twist the end of strand wire and make sure there are no loose wires.
 - Do not solder-plate the electric wire ends.
 - Do not connect more than the specified number of wires or electric wires of unspecified size.
 - Affix the electric wires so that neither the terminal block nor the connected parts are directly stressed.

A
Common Items

B
FX3U-4AD
FX3UC-4AD

C
FX3U-4AD-ADP

D
FX3G-2AD-BD

E
FX3U-4DA

F
FX3U-4DA-ADP

G
FX3G-1DA-BD

H
FX3U-3A-ADP

I
FX3U-4AD-PT
-ADP

J
FX3U-4AD-PTW
-ADP

3.1 Terminal Layout

The terminals of the 1DA-BD are arranged as follows:

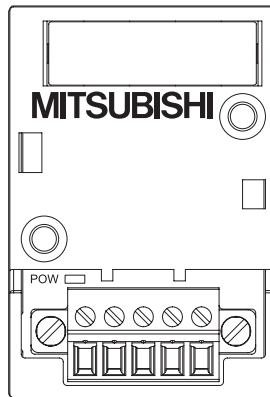

Signal	•	•	V+	I+	VI-
Application	Unused terminal		Output terminal		COM terminal

3.2 Applicable Cables and Terminal Tightening Torque

Use the following cables to connect with the counterpart equipment. Terminate the cable end as shown below.

1. Cable

Applicable cable and tightening torque

	Wire size (stranded/ single-wire)	Tightening torque	Termination
Single-wire	0.3mm ² to 0.5mm ² (AWG22 to 20)	0.22N•m to 0.25N•m	<ul style="list-style-type: none"> To connect a stranded cable, peel the cover off the cable and then twist the core before connection. To connect a single-wire cable, just peel the cover off the cable before connection. Rod terminal with insulation sleeve (recommended terminal) AI 0.5-8WH : Manufactured by Phoenix Contact Caulking tool CRIMPFOX 6*1 : Manufactured by Phoenix Contact (or CRIMPFOX 6T-F*2 : Manufactured by Phoenix Contact)
2-wire	0.3mm ² (AWG22)		
Rod terminal with insulation sleeve	0.3mm ² to 0.5mm ² (AWG22 to 20) (Refer to the rod terminal external view shown in the following figure.)		

- *1. Old model name : CRIMPFOX ZA 3
- *2. Old model name : CRIMPFOX UD 6

2. Termination of cable end

To terminate the cable, treat the stranded/single wire directly or use a rod terminal with insulation sleeve.

- To directly terminate the end of a stranded/single-wire cable:
 - Twist the end of the stranded cable so that the "barbed wires" cannot protrude.
 - Do not solder-plate the end of the cable.
- To terminate cable end using a rod terminal with insulation sleeve:
 If the cable cover is too thick, it may be difficult to insert the cable into the insulation sleeve. For this reason, select an appropriate cable while referring to the external view.
 <Reference>

Termination of cable end

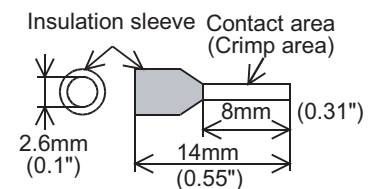
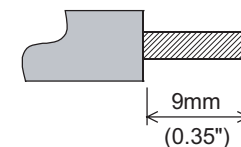

Manufacturer	Model	Caulking tool
Phoenix Contact	AI 0.5-8WH	CRIMPFOX 6*3 (or CRIMPFOX 6T-F*4)

- *3. Old model name : CRIMPFOX ZA 3
- *4. Old model name : CRIMPFOX UD 6

3. Tool

- To tighten terminals, use a small-sized screwdriver whose head is straight and is not widened as shown in the figure to the right.

Note:

If the diameter of screwdriver grip is too small, tightening torque will not be able to be achieved. To achieve the appropriate tightening torque shown in the table above, use the following screwdriver or an appropriate replacement (grip diameter: approximately 25mm (0.98")).
 <Reference>

Manufacturer	Model
Phoenix Contact	SZS 0.4×2.5

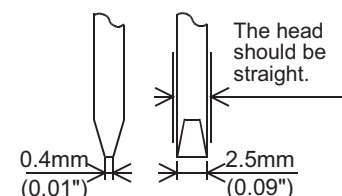

3.3 Analog Output Line

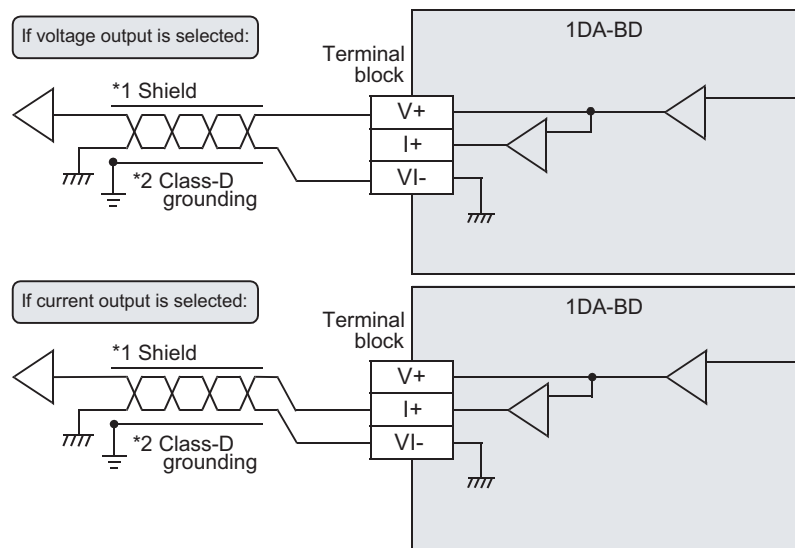

- *1. Use 2-core shielded twisted pair cable for the analog output lines, and separate the analog output lines from other power lines or inductive lines.
- *2. Ground the shielded wire at one point on the signal receiving side.

3.4 Grounding

Grounding should be performed as stated below.

- The grounding resistance should be 100Ω or less.
- Independent grounding should be performed for best results.
 When independent grounding is not performed, perform "shared grounding" as shown in the following figure.

→ For details, refer to User's Manual - Hardware Edition of the PLC Series.

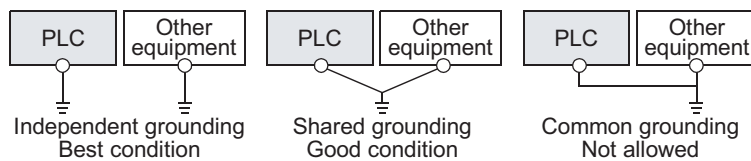

- The grounding wire size should be AWG22 to 20 (0.3 to 0.5 mm²).
- The grounding point should be close to the PLC, and all grounding wires should be as short as possible.

4. Programming

This chapter describes how to create programs that can output the analog data using the 1DA-BD.

4.1 Writing of D/A Conversion Data

- 1) The input digital data will be converted into analog data and then output to the terminals.
- 2) If data is stored in the special devices, the averaging time can be set, and the output mode can be specified.
- 3) Special auxiliary relays (10 points) and special data registers (10 points) are assigned respectively to the analog expansion board (board A) connected to option connector 1 and the analog expansion board (board B) connected to option connector 2 in this order.

→ For a detailed description of special device assignment, refer to Section 4.2.

- FX3G Series PLC

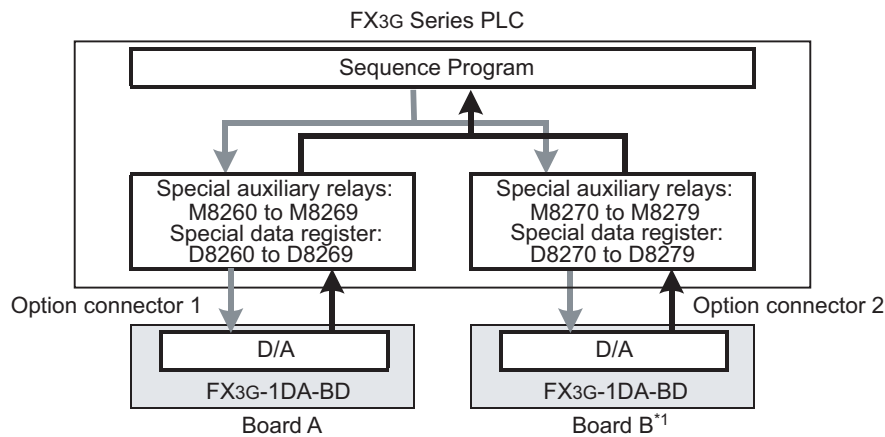

The analog expansion board connected to option connector 1 is regarded as the "board A", and the analog expansion board connected to option connector 2 is regarded as the "board B".

- *1. Board B is not available in the FX3G Series PLC(14-point and 24-point type).

4.2 List of Special Devices

If 1DA-BD is connected, special devices will be assigned automatically as shown in the following table:
 R: Read / W: Write

Special device	Device number		Description	Attribute	Reference
	Board A	Board B			
Special auxiliary relay	M8260	M8270	Switches the output mode.	R/W	Section 4.3
	M8261 to M8263	M8271 to M8273	Unused (Do not use.)	-	-
	M8264	M8274	Sets the cancel of output holding function.	R/W	Section 4.4
	M8265 to M8269	M8275 to M8279	Unused (Do not use.)	-	-
Special data register	D8260	D8270	Output setting data	R/W	Section 4.5
	D8261 to D8267	D8271 to D8277	Unused (Do not use.)	-	-
	D8268	D8278	Error status	R/W	Section 4.6
	D8269	D8279	Model code = 4	R	Section 4.7

4.3 Switching of Output Mode

Turn the special auxiliary relay on/off to switch the output mode of 1DA-BD between the current output mode and the voltage output mode.

To switch the output mode, use the following special auxiliary relays:

Special auxiliary relay		Description
Board A	Board B	
M8260	M8270	Switches the output mode. OFF:Voltage output ON :Current output

1. Program Example

To switch the output mode, create a sequence program as follows:

To switch the channel output mode of the board A to the voltage output mode:

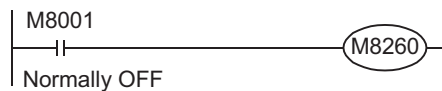

4.4 Output Holding Function Cancellation Setting

This setting can hold the analog data output or to output the offset data (0V for voltage output mode, 4mA for current output mode) when the PLC stops.

To cancel or set the output holding function, use the following special auxiliary relays:

Special auxiliary relay		Description
Board A	Board B	
M8264	M8274	Cancel output holding function setting. OFF: Holds the analog data output just before stop of the PLC. ON: Outputs the offset data at stop of the PLC.

1. Program Example

To set or cancel the output holding function, create a sequence program as follows:

To set the output holding function for the board A:

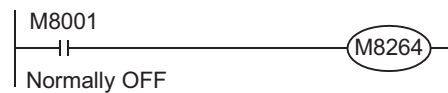

4.5 Output Setting Data

Numeric data type: Decimal (K)

The 1DA-BD performs D/A conversion on the output setting data (digital data) into analog data, and outputs the analog data.

Use the special data registers shown in the following table for the output setting data:

Special data register		Description
Board A	Board B	
D8260	D8270	Output setting data

1. Program Example

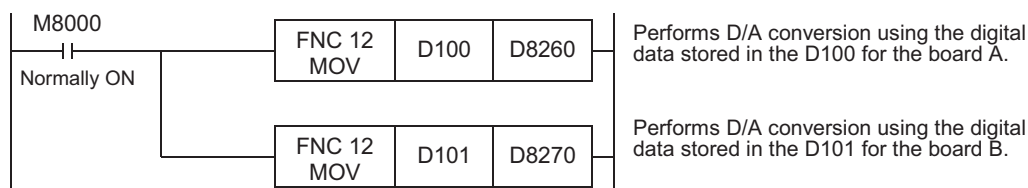

Using the indicator or the sequence program, input the digital data to be subject to D/A conversion (to be output as analog data) in D100 and D101.

4.6 Error Status

1. Description of setting

If an error is detected on 1DA-BD, the error status data will be stored in the corresponding special data register.

The following table shows the special data registers that store the error status data:

Special data register		Description
Board A	Board B	
D8268	D8278	Stores the error status data.

Check the ON/OFF status of each bit of the error status data register to check the description of the error. Errors are assigned to the bits as shown in the following table. Create a program to detect errors.

Bit	Description
b0	Output data setting error
b1 to b3	Unused
b4	EEPROM error
b5 to b15	Unused

2. Program Example

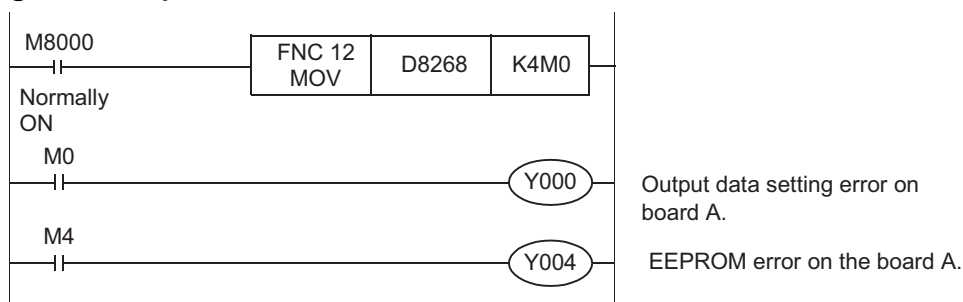

4.7 Model Code

Initial value: K4
Numeric data type: Decimal (K)

1. Description of setting

When the 1DA-BD is connected, model code "4" is stored in the corresponding special data register.

The following table shows the special data registers that store the model code:

Special data register		Description
Board A	Board B	
D8269	D8279	Model code

Use the special data registers above to check whether 1DA-BD is connected or not.

2. Program Example



4.8 Basic Program Example

Create the following basic program example to output D/A converted analog data.
 The following program will set the board A to the voltage output mode and board B to current output mode, and will set digital data in D100 and D101 for D/A conversion.

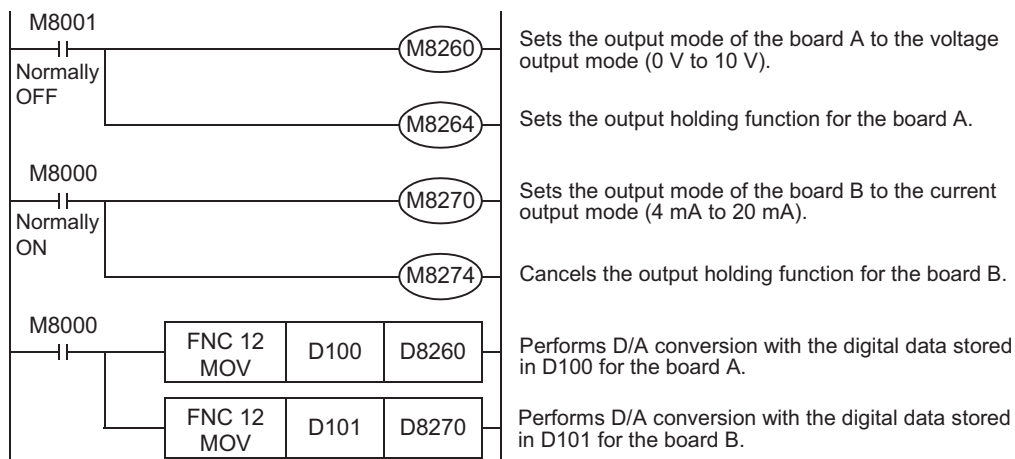

Using the indicator or the sequence program, input the digital data to be subject to D/A conversion (to be output as analog data) in D100 and D101.

A
Common Items

B
FX3U-4AD
FX3UC-4AD

C
FX3U-4AD-ADP

D
FX3G-2AD-BD

E
FX3U-4DA

F
FX3U-4DA-ADP

G
FX3G-1DA-BD

H
FX3U-3A-ADP

I
FX3U-4AD-PT-ADP

J
FX3U-4AD-PTW-ADP

5. Changing of Output Characteristics

The output characteristics can be changed using sequence programs in FX3G Series PLCs.

5.1 Example: Changing of Voltage Output Characteristics

This section describes an example of a program that can change the digital value range from 400 to 2000 (when analog output range is 1 to 5V) to 0 to 10000. A specified digital value is inputted into D100.

1. Output characteristics

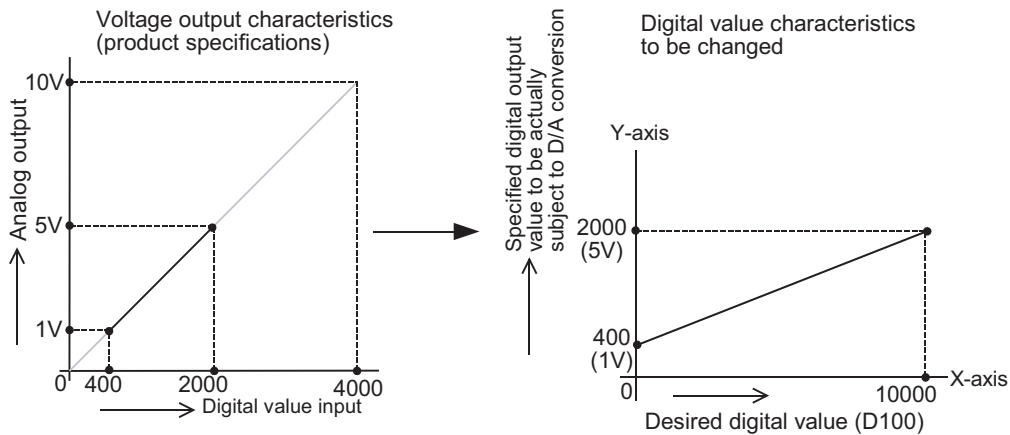

2. Example of program

For example, create the following program to change the digital output data (D100) of the board A.

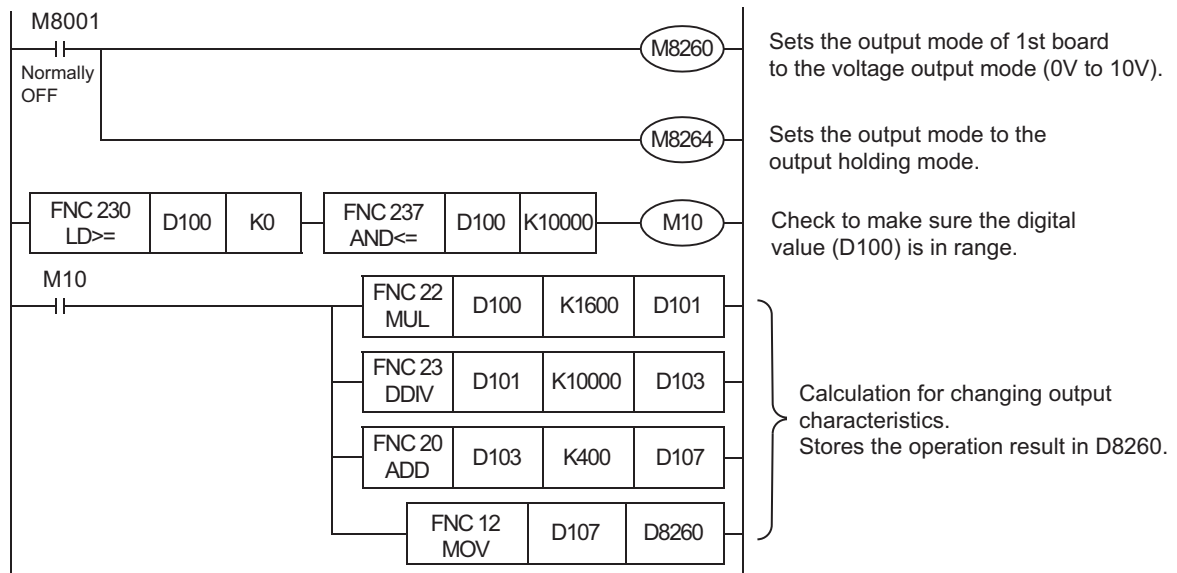

6. Troubleshooting

This chapter describes the troubleshooting methods and error status.
If analog data is not output, or if the proper analog value is not output, check the following items:

- Version number of PLC
- Installation
- Wiring
- Special devices
- Programs
- Error status

6.1 PLC Version Number Check

- Check the version number of the FX3G Series PLC. The version number should be 1.10 or later.
→ For a detailed description of the version number check method, refer to Section 1.3.

6.2 Checking installation

- Confirm that the 1DA-BD is attached correctly to the main unit. Confirm also that the POW indicator lamp of the 1DA-BD is lit correctly.
→ For a detailed description of installing, refer to FX3G User's Manual-Hardware Edition.

6.3 Wiring Check

Check the following items for wiring:

1. Analog output line

Use the 2-core twisted shielded pair cable for the analog output line. In addition, be sure to separate the analog output line from other power lines or inductive lines.

→ For a detailed description of wiring, refer to Chapter 3.

6.4 Special Device Check

Check whether the special devices for the 1DA-BD are being used correctly:

1. Output mode switching

Verify that the special device for switching the output mode is correctly set.

Turn off the device to set the output mode to the voltage output mode. Turn on the device to set the output mode to the current output mode.

2. Output setting data

Check that the special device is correctly selected. This special device should be selected depending on the connected position and the channel.

3. Error status

Check that no error is detected in the 1DA-BD.

If an error is detected, check the details of the error, and then check the wiring and programs.

→ For a detailed description of special devices, refer to Chapter 4.

A
Common Items

B
FX3U-4AD
FX3UC-4AD

C
FX3U-4AD-ADP

D
FX3G-2AD-BD

E
FX3U-4DA

F
FX3U-4DA-ADP

G
FX3G-1DA-BD

H
FX3U-3A-ADP

I
FX3U-4AD-PT-ADP

J
FX3U-4AD-PTW-ADP

6.5 Program Check

Check the following items for the program:

1. Device for setting specified digital value

Check that different values are not written to this device using other programs.

6.6 Error Status Check

If an error occurs in the 1DA-BD, the corresponding bit will turn on.

The bit which is turned ON due to the error status is held ON until overwritten to OFF by the program or the power is cycled.

Bit	Description
b0	Output data setting error
b1 to b3	Unused
b4	EEPROM error
b5 to b15	Unused

To solve the problem, refer to the troubleshooting method described below:

1. Output data setting error (b0)

- 1) Description of error
The specified digital value is outside the specified range.
Analog data will not be correctly output.
- 2) Remedy
Check that the specified digital value is within the specified range.

2. EEPROM error (b4)

- 1) Description of error
The adjustment data set in the EEPROM before delivery from our factory cannot be read out properly or is destroyed.
- 2) Remedy
Please contact the nearest Mitsubishi Electric distributor office.

FX3G/FX3U/FX3UC Series Programmable Controllers

User's Manual [Analog Control Edition]

FX3U-3A-ADP

(2-channel analog Input, 1-channel analog output)

Foreword

This manual describes the specifications, wiring, and operation methods for the FX3U-3A-ADP analog special adapter (2-channel analog input, 1-channel analog output) and should be read and understood before attempting to install or use the unit.

Store this manual in a safe place so that you can take it out and read it whenever necessary. Always forward it to the end user.

This manual confers no industrial property rights or any rights of any other kind, nor does it confer any patent licenses. Mitsubishi Electric Corporation cannot be held responsible for any problems involving industrial property rights which may occur as a result of using the contents noted in this manual.

© 2005 MITSUBISHI ELECTRIC CORPORATION

A
Common Items

B
FX3U-4AD
FX3UC-4AD

C
FX3U-4AD-ADP

D
FX3G-2AD-BD

E
FX3U-4DA

F
FX3U-4DA-ADP

G
FX3G-1DA-BD

H
FX3U-3A-ADP

I
FX3U-4AD-PT
-ADP

J
FX3U-4AD-PTW
-ADP

1. Outline

This chapter outlines the FX3U-3A-ADP (referred to as the 3A-ADP).

1.1 Outline of Functions

The analog special adapter FX3U-3A-ADP receives voltage/current data from 2 channels and outputs voltage/current data from 1 channel when connected to a FX3U/FX3UC/FX3G Series PLC.

- 1) Up to 4 3A-ADP units can be connected to the FX3U/FX3UC Series PLC.
 Up to 2*1 3A-ADP units can be connected to the FX3G Series PLC.
 (including the other analog special adapters).
- 2) The 3A-ADP receives and outputs voltage/current data.
- 3) A/D conversion data of each channel will be automatically written to the special data register of the FX3U/FX3UC/FX3G Series PLC.
- 4) D/A conversion results will be automatically output as the values to the special data register of the FX3U/FX3UC/FX3G Series PLC.

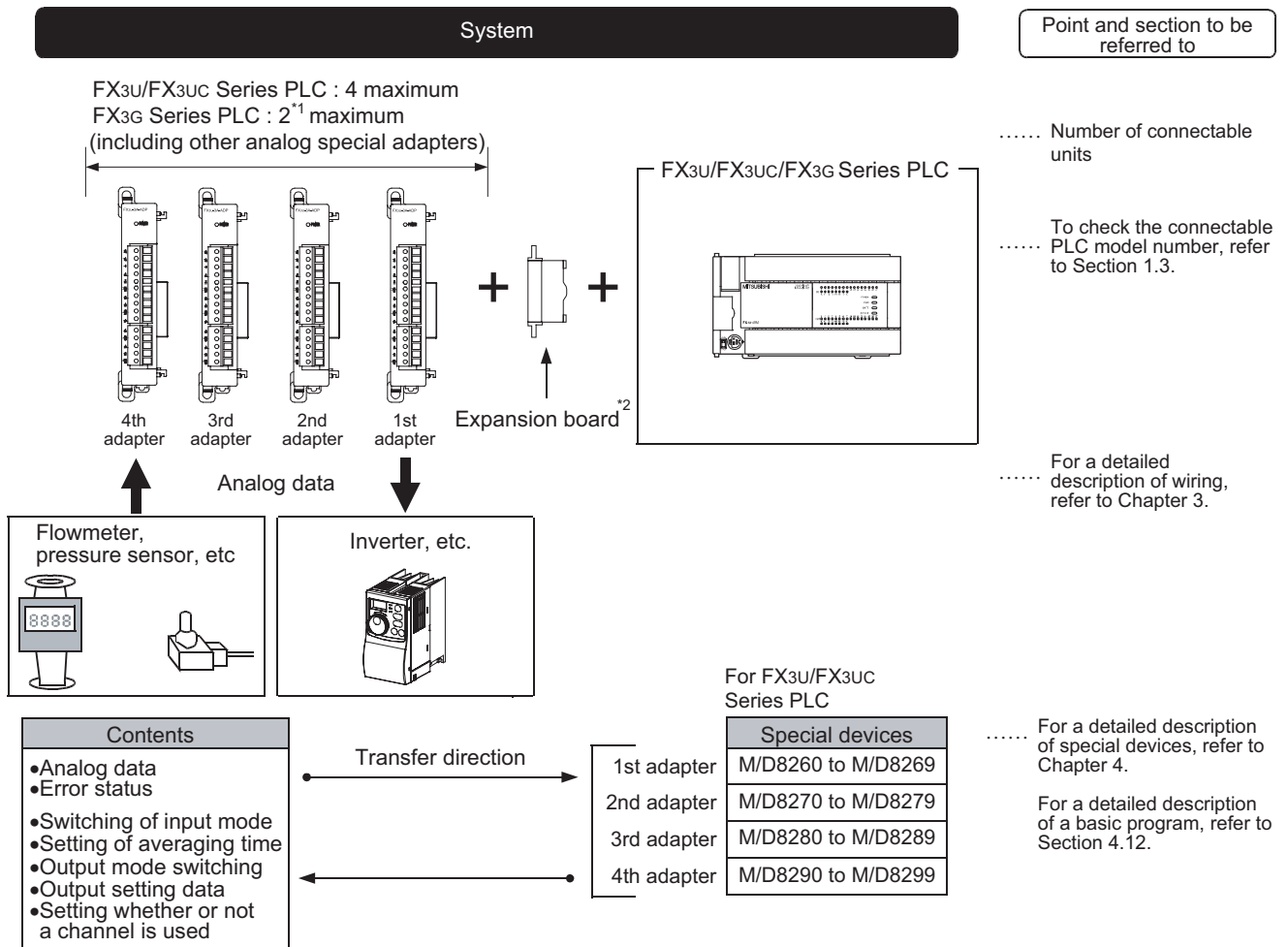

Refer to the system configuration shown in the User's Manual - Hardware Edition to check the number of connectable units and to configure the entire system.

*1. Only 1 analog special adapter can be connected to the FX3G Series PLC (14-point and 24-point type).

*2. The expansion board is not required when connecting with the FX3UC (D, DSS) PLC.
 For the FX3G Series PLC a connector conversion adapter is used.

1.2 Setup Procedure Before Starting Operation

Before starting analog input / output using the 3A-ADP, follow the procedure below to set up the system:

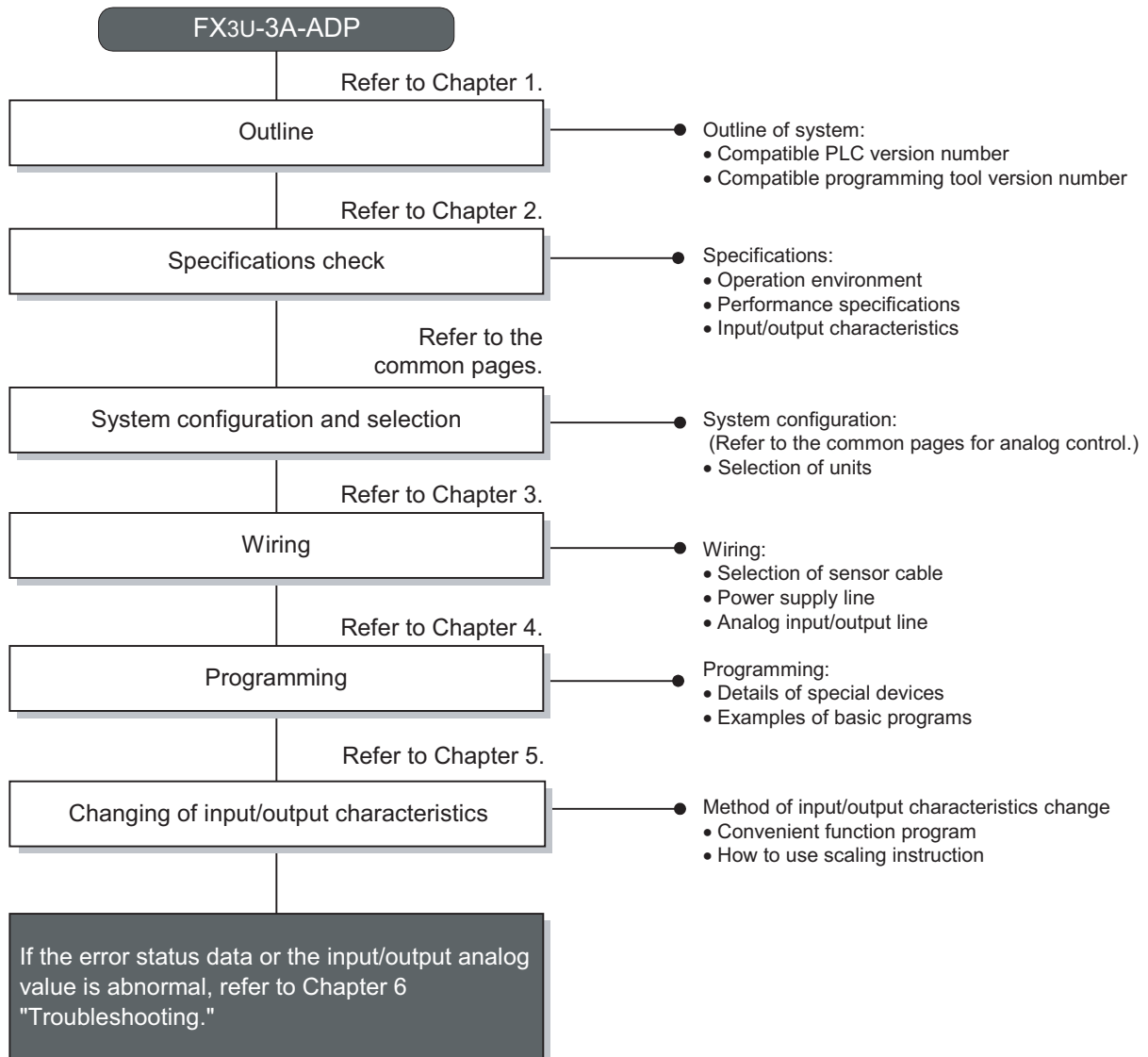

1.3 Connectable PLCs and Version Number

The 3A-ADP is compatible with the following PLC.

Compatible PLC	Version number	Date of production
FX3U Series PLC	Ver.2.61 or later*1	After July 2009
FX3UC Series PLC	Ver.2.61 or later*1	After July 2009
FX3G Series PLC	Ver.1.20 or later	After June 2009

*1. The FX3U/FX3UC Series PLC ver. 2.70 or later supports the under-scale detection.

1. Version check

Special data register D8001 contains information for determining the PLC version number.

→ For a detailed description of the version check, refer to A. Common Items Subsection 5.1.2.

2. How to check the manufacturer's serial number

The year and month of production of the product can be checked on the nameplate, and on the front of the product.

→ For a detailed description of how to check the manufacturer's serial number, refer to A. Common Items Subsection 5.1.1.

1.4 Compatible Programming Tool Version Number

Use the programming tool with following version numbers to create programs for the 3A-ADP:

1. GX Works2

Software	Version number	Remarks
GX Works2 SW□DNC-GXW2-J	Ver. 1.07H or later	-
GX Works2 SW□DNC-GXW2-E	Ver. 1.08J or later	-

2. GX Developer

- FX3U/FX3UC Series PLC

Software	Version number	Remarks
GX Developer SW□D5C-GPPW-J	Ver. 8.13P or later	When selecting the model, select FX3U(C)*2.
GX Developer SW□D5C-GPPW-E	Ver. 8.18U or later	

- FX3G Series PLC

Software	Version number	Remarks
GX Developer • SW□D5C-GPPW-J • SW□D5C-GPPW-E	Ver. 8.72A or later	-

If a programming tool with the wrong version number is used, programming will not be possible.

*2. For Ver. 8.13P to 8.24A of GX Developer, select FX3UC for the PLC type.

3. FX-30P

Model name	Version number	Remarks
FX-30P	Ver. 1.00 or later	-

2. Specifications

This chapter describes the general, power supply, and performance specifications for the 3A-ADP.

2.1 Generic Specifications

Item	Specifications				
Ambient temperature	0 to 55°C (32 to 131°F) when operating -25 to 75°C (-13 to 167°F) when stored				
Relative humidity	5 to 95%RH (no condensation) when operating				
Vibration resistance*1	DIN Rail Mounting	Frequency (Hz)	Acceleration (m/s ²)	Half amplitude (mm)	Tests 10 times in each direction (X-, Y-, and Z-axis directions) (Total: 80 min, each)
		10 to 57	-	0.035	
	Direct Mounting*2	57 to 150	4.9	-	
		10 to 57	-	0.075	
Shock resistance*1	147 m/s ² Acceleration, Action time: 11ms, 3 times by half-sine pulse in each direction X, Y, and Z				
Noise resistance	Using noise simulator of: Noise voltage: 1,000Vp-p / Noise width: 1μs / Rise: 1ns / Cycle: 30 to 100Hz				
Dielectric withstand voltage	500 V AC, for 1 min		Between all terminals and ground terminal		
Insulation resistance	5MΩ or more using 500V DC insulation resistance meter				
Grounding	Class D grounding (grounding resistance: 100 Ω or less) <Common grounding with a heavy electrical system is not allowed.>*3				
Working environment	Free from corrosive or flammable gas and excessive conductive dusts				
Working altitude	< 2000m*4				

*1. The criterion is shown in IEC61131-2.

*2. If 3A-ADP is connected to the FX3UC Series PLC, direct installation is not possible.

*3.

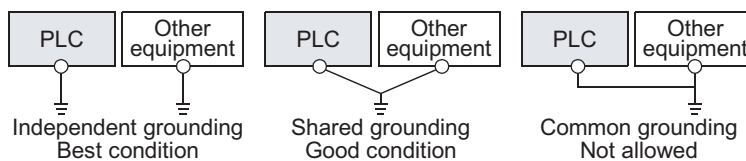

→ For a detailed description of the grounding, refer to Section 3.5.

*4. If the pressure is higher than the atmospheric pressure, do not use the 3A-ADP.
 The 3A-ADP may malfunction.

2.2 Power Supply Specifications

Item	Specifications
Conversion circuit driving power	24V DC +20%-15%, 90mA (It is necessary to connect a 24V DC power line to the terminal block.)
Interface driving power	5V DC, 20mA (Since the internal power is supplied from the main unit of the FX Series, it is not necessary to supply the power.)

2.3 Performance Specifications

Item	Specifications				
	Voltage input	Current input	Voltage output	Current output	
Number of input/output points	2ch		1ch		
Analog input/output range	0V to 10V DC (Input resistance:198.7kΩ)	4mA to 20mA DC (Input resistance:250Ω)	0V to 10V DC (External load:5k to 1MΩ)	4mA to 20mA DC (External load:500Ω or less)	
Absolute maximum input	-0.5V, +15V	-2mA, +30mA	-	-	
Digital input/output	12 bits, binary				
Resolution	2.5mV(10V×1/4000)	5μA(16mA×1/3200)	2.5mV(10V×1/4000)	4μA(16mA×1/4000)	
Overall accuracy	Ambient temperature: 25±5°C	±0.5%(±50mV) for 10V full scale	±0.5%(±80μA) for 16mA full scale	±0.5%(±50mV) for 10V full scale	±0.5%(±80μA) for 16mA full scale
	Ambient temperature: 0 to 55°C	±1.0%(±100mV) for 10V full scale	±1.0%(±160μA) for 16mA full scale	±1.0%(±100mV) for 10V full scale	±1.0%(±160μA) for 16mA full scale
	Reference	-	-	If the external load resistance (Rs) is less than 5kΩ, the accuracy increases as shown in the following formula: (Increase: 100 mV per 1%) $\frac{47 \times 100}{R_s + 47} - 0.9(\%)$	-
Time required for conversion	<ul style="list-style-type: none"> FX3U/FX3UC Series PLC : 80μs for each selected input channel + 40μs for each selected output channel (Operation synchronized with sequence program) FX3G Series PLC : 90μs for each selected input channel + 50μs for each selected output channel (Operation synchronized with sequence program) <p>→ For a detailed description of data update, refer to Section 2.4.</p>				
I/O characteristics					
Insulation method	<ul style="list-style-type: none"> The photocoupler is used to insulate the analog input and output area from the PLC. The DC/DC converter is used to insulate the power supply from the analog input and output area. Channels are not insulated from each other. 				
Number of I/O points occupied	0 points (This number of points is not related to the maximum number of input/output points of the PLC.)				

2.4 Conversion Time

This section describes the conversion time.

2.4.1 When connected to a FX3U, FX3UC PLC

1. Conversion and special data register update timing

A/D and D/A conversion is performed at every scan time of the PLC.

During execution of END instruction, the PLC performs A/D conversion, reads out the A/D converted data, and then writes the data in the special data registers.

The PLC writes output setting data to special data registers, performs D/A conversion, and updates analog output values.

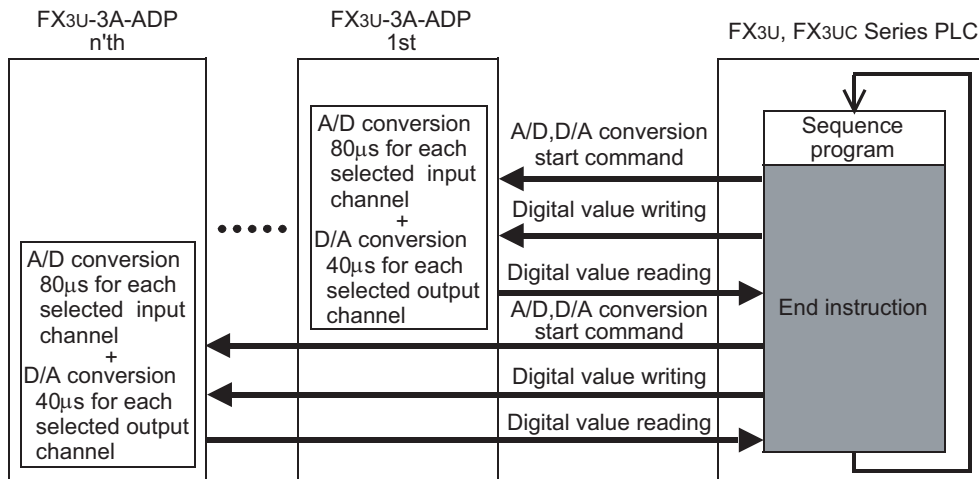

2. Conversion during PLC STOP

- 1) A/D conversion
 Even if the PLC is stopped, A/D conversion will be performed and the special data registers will be updated.
- 2) D/A conversion
 If the output holding function cancellation setting is disabled by the special device, the offset value will be output.
 If the output holding function cancellation setting is enabled, the output at switching from RUN to STOP will be latched.
 Just after power-on, however, the offset value will be output until operation begins.

3. If two or more analog special adapters are connected

- 1) A/D conversion
 During execution of the END instruction, data will be read out from all the connected adapters (in the order of 1st adapter → 2nd adapter... 4th adapter).
- 2) D/A conversion
 During execution of the END instruction, data in all the connected adapters will be subject to D/A conversion and then output (in the order of 1st adapter → 2nd adapter... 4th adapter).

4. Conversion speed (data update time)

- 1) A/D conversion
 During execution of END instruction, the A/D converted data of "80μs for each selected input channel", and the data read out will be written to the special data registers.
 END instruction execution time will be "80μs for each selected input channel × number of connected analog adapters."
- 2) D/A conversion
 During execution of END instruction, the output setting digital data per of "40μs for each selected output channel", after which the analog data will be output.
 END instruction execution time will be "40μs for each selected output channel × number of connected adapters."

2.4.2 When connected to a FX3G PLC

1. Conversion and special data register update timing

A/D and D/A conversion is performed at every scan time of the PLC.

During execution of END instruction, the PLC performs A/D conversion, reads out the A/D converted data, and then writes the data in the special data registers.

The PLC writes output setting data to special data registers, performs D/A conversion, and updates analog output values.

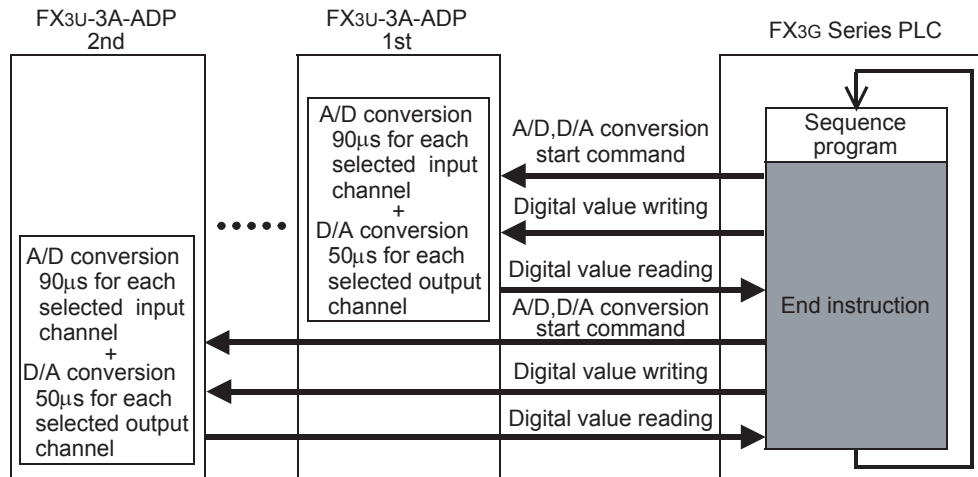

2. Conversion during PLC STOP

- 1) A/D conversion
 Even if the PLC is stopped, A/D conversion will be performed and the special data registers will be updated.
- 2) D/A conversion
 If the output holding function cancellation setting is disabled by the special device, the offset value will be output.
 If the output holding function cancellation setting is enabled, the output at switching from RUN to STOP will be latched.
 Just after power-on, however, the offset value will be output until operation begins.

3. If two or more analog special adapters are connected

- 1) A/D conversion
 During execution of the END instruction, data will be read out from all the connected adapters (in the order of 1st adapter → 2nd adapter).
- 2) D/A conversion
 During execution of the END instruction, data in all the connected adapters will be subject to D/A conversion and then output (in the order of 1st adapter → 2nd adapter).

4. Conversion speed (data update time)

- 1) A/D conversion
 During execution of END instruction, the A/D converted data of "90µs for each selected input channel", and the data read out will be written to the special data registers.
 END instruction execution time will be "90µs for each selected input channel × number of connected analog adapters."
- 2) D/A conversion
 During execution of END instruction, the output setting digital data per of "50µs for each selected output channel", after which the analog data will be output.
 END instruction execution time will be "50µs for each selected output channel × number of connected adapters."

3. Wiring

This chapter describes the 3A-ADP wiring.
Observe the following caution to wire the 3A-ADP.

WIRING PRECAUTIONS



DANGER

- Make sure to cut off all phases of the power supply externally before attempting wiring work. Failure to do so may cause electric shock or damages to the product.

WIRING PRECAUTIONS



CAUTION

- Connect the DC power supply wiring to the dedicated terminals described in this manual. If an AC power supply is connected to a DC input/output terminal or DC power supply terminal, the PLC will be burnt out.
- Do not wire vacant terminals externally. Doing so may damage the product.
- Perform class D grounding (grounding resistance: 100Ω or less) to the grounding terminal on the main unit. Do not use common grounding with heavy electrical systems.
- When drilling screw holes or wiring, make sure cutting or wire debris does not enter the ventilation slits. Failure to do so may cause fire, equipment failures or malfunctions.
- Make sure to observe the following precautions in order to prevent malfunctions under the influence of noise:
 - Do not bundle the power line or twisted shielded cable together with or lay it close to the main circuit, highvoltage line, or load line. Otherwise, noise disturbance and/or surge induction are likely to take place. As a guideline, lay the control line at least 100mm (3.94") or more away from the main circuit, high-voltage line, or load line.
 - Ground the shield of the analog input/output cable at one point on the signal receiving side. However, do not use common grounding with heavy electrical systems.
- Make sure to properly wire to the European terminal board in accordance with the following precautions. Failure to do so may cause electric shock, equipment failures, a short-circuit, wire breakage, malfunctions, or damage to the product.
 - The disposal size of the cable end should follow the dimensions described in the manual.
 - Tightening torque should follow the specifications in the manual.
 - Twist the end of strand wire and make sure there are no loose wires.
 - Do not solder-plate the electric wire ends.
 - Do not connect more than the specified number of wires or electric wires of unspecified size.
 - Affix the electric wires so that neither the terminal block nor the connected parts are directly stressed.

3.1 Terminal Layout

The terminals of the 3A-ADP are arranged as follows:

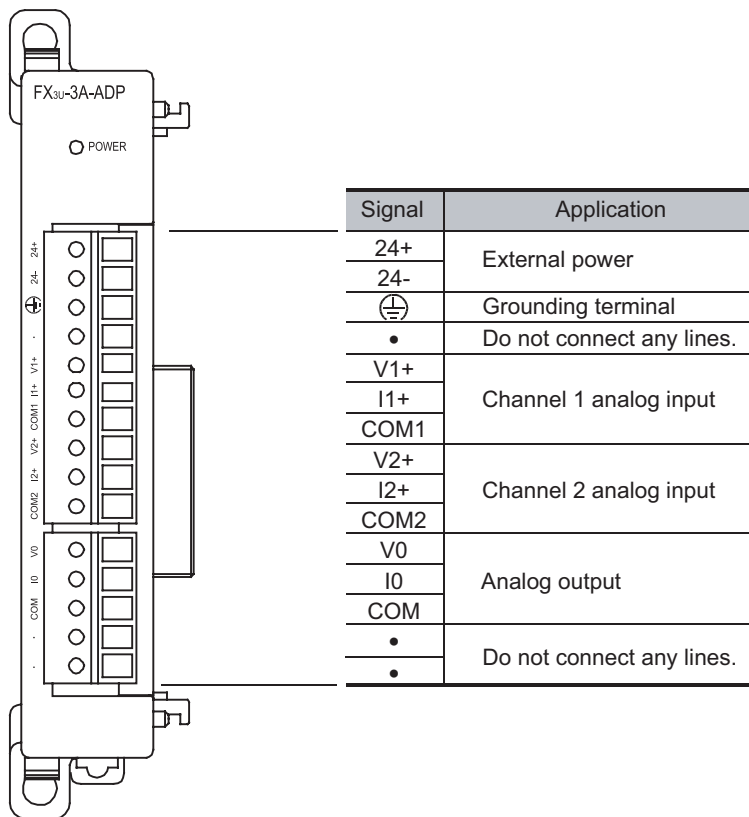

A
Common Items

B
FX3U-4AD
FX3UC-4AD

C
FX3U-4AD-ADP

D
FX3G-2AD-BD

E
FX3U-4DA

F
FX3U-4DA-ADP

G
FX3G-1DA-BD

H
FX3U-3A-ADP

I
FX3U-4AD-PT
-ADP

J
FX3U-4AD-PTW
-ADP

3.2 Applicable Cables and Terminal Tightening Torque

Use the following cables to connect with the counterpart equipment. Terminate the cable ends as shown below.

1. Cables

Applicable cable and tightening torque

	Wire size (stranded/ single-wire)	Tightening torque	Termination
Single-wire	0.3mm ² to 0.5mm ² (AWG22 to 20)	0.22N•m to 0.25N•m	<ul style="list-style-type: none"> To connect a stranded cable, peel the cover off the cable and then twist the core before connection. To connect a single-wire cable, just strip the cover off the cable before connection. Rod terminal with insulation sleeve (recommended terminal) AI 0.5-8WH : Manufactured by Phoenix Contact Caulking tool CRIMPFOX 6*1 : Manufactured by Phoenix Contact (or CRIMPFOX 6T-F*2 : Manufactured by Phoenix Contact)
2-wire	0.3mm ² (AWG22)		
Rod terminal with insulation sleeve	0.3mm ² to 0.5mm ² (AWG22 to 20) (Refer to the rod terminal external view shown in the following figure.)		

*1. Old model name : CRIMPFOX ZA 3

*2. Old model name : CRIMPFOX UD 6

2. Termination of cable end

To terminate the cable, treat the stranded/single-wire directly or use a rod terminal with insulation sleeve.

- To directly terminate the end of a stranded/single-wire cable:
 - Twist the end of the stranded cable so that the "barbed wires" cannot protrude.
 - Do not solder-plate the end of the cable.
- To terminate cable end using a rod terminal with insulation sleeve:
 If the cable cover is too thick, it may be difficult to insert the cable into the insulation sleeve. For this reason, select an appropriate cable while referring to the external view.

<Reference>

Manufacturer	Model	Caulking tool
Phoenix Contact	AI 0.5-8WH	CRIMPFOX 6*3 (or CRIMPFOX 6T-F*4)

*3. Old model name : CRIMPFOX ZA 3

*4. Old model name : CRIMPFOX UD 6

Termination of cable end

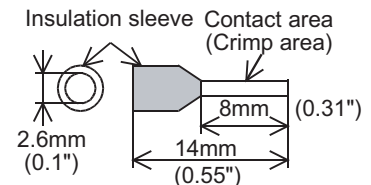
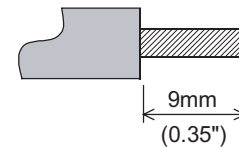

3. Tool

- To tighten terminals, use a small-sized screwdriver whose head is straight and is not widened as shown in the figure to the right.

Note:

If the diameter of screwdriver grip is too small, tightening torque will not be able to be achieved. To achieve the appropriate tightening torque shown in the table above, use the following screwdriver or an appropriate replacement (grip diameter: approximately 25mm (0.98")).

<Reference>

Manufacturer	Model
Phoenix Contact	SZS 0.4×2.5

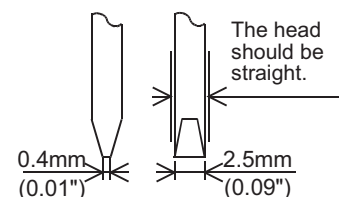

3.3 Power Supply Line

Connect the 24V DC power supply line of the 3A-ADP to the 24+ and 24- terminals of the terminal block.

3.3.1 To connect to the FX3G, FX3U Series PLC

1. To use an External power supply

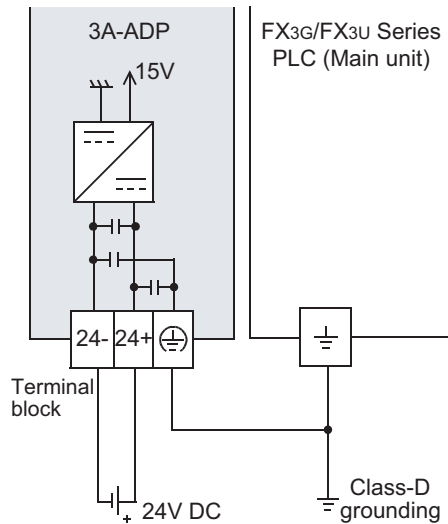

2. To use the 24V DC power of the PLC

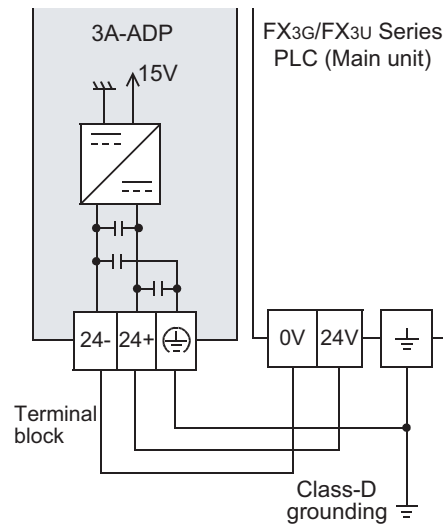

Caution regarding connection of the power supply line:

- Ground the "⊕" terminal to a class-D grounded power supply line (100Ω or less) together with the grounding terminal of the PLC main unit.
- When using an external power supply, turn it ON at the same time with the main unit or earlier than the main unit. When turning OFF the power, confirm the safety of the system, and then turn OFF the power of the PLC (including special adapter) at the same time.

3.3.2 To connect to the FX3UC Series PLC

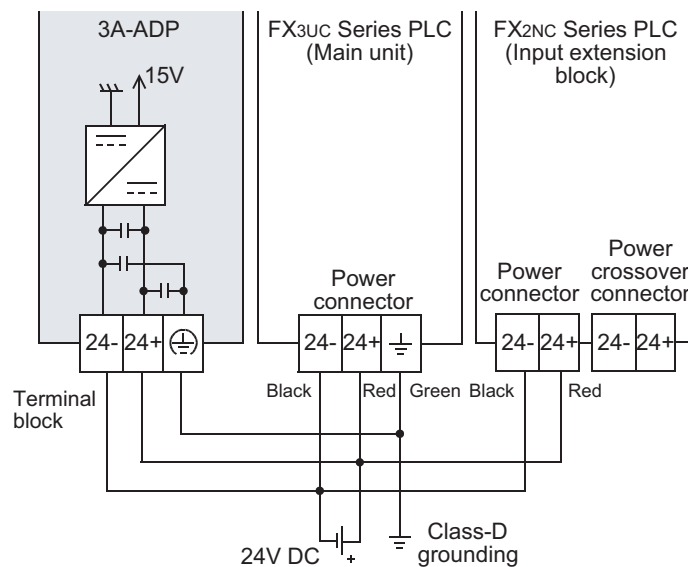

Cautions regarding connection of the power supply line:

- For the 24V DC power supply line, be sure to use the same power as the FX3UC Series PLC.
- Ground the "⊕" terminal to a class-D grounded power supply line (100Ω or less) together with the grounding terminal of the PLC main unit.

3.4 Analog Input / output Line

3.4.1 Analog Input Line

For analog input, "voltage input" or "current input" can be selected for each channel.

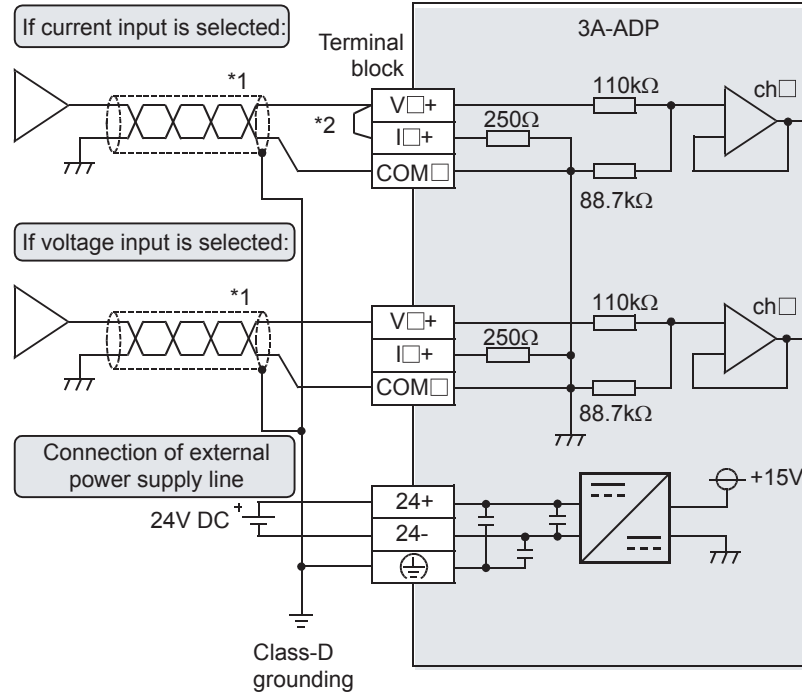

V□+, I□+, ch□ : represents the channel number.

- *1. Use the 2-core shielded twisted pair cable for the analog input lines, and separate the analog input lines from other power lines or inductive lines.
- *2. If "current input" is selected, be sure to short the line between the V□+ terminal and the I□+ terminal. (□: Channel number).

3.4.2 Analog Output Line

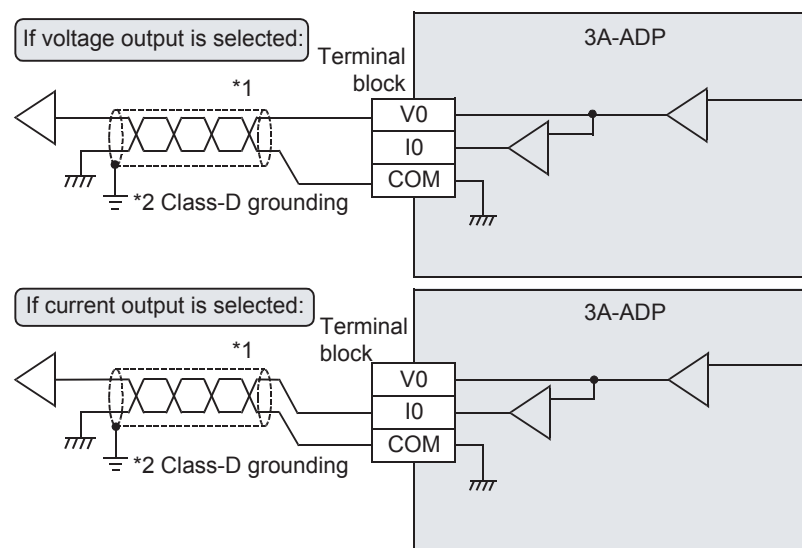

- *1. Use 2-core shielded twisted pair cable for the analog output lines, and separate the analog output lines from other power lines or inductive lines.
- *2. Ground the shielded wire at one point on the signal receiving side.

3.5 Grounding

Grounding should be performed as stated below.

- The grounding resistance should be 100Ω or less.
- Independent grounding should be performed for best results.
When independent grounding is not performed, perform "shared grounding" as shown in the following figure.

→ For details, refer to the User's Manual - Hardware Edition of the PLC Series.

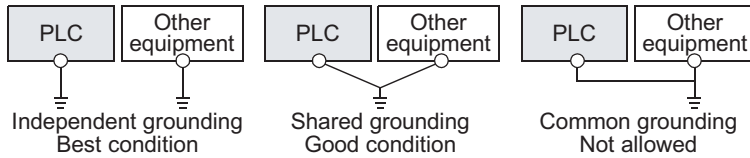

- The grounding wire size should be AWG22 to 20 (0.3 to 0.5 mm²).
- The grounding point should be close to the PLC, and all grounding wires should be as short as possible.

4. Programming

This chapter explains how to create programs for inputting and outputting analog data using the 3A-ADP.

4.1 Loading/Writing of Conversion Data

Loading of A/D Conversion Data

- 1) The input analog data will be converted into digital data and then stored in the special devices of the FX3U/FX3UC/FX3G Series PLC.
- 2) If the data is stored in the special devices, the averaging time can be set, and the input mode can be specified.
- 3) Special auxiliary relays (10 points) and special data registers (10 points) are assigned automatically starting from the adapter nearest the main unit.
 → For a detailed description of special device assignment, refer to Section 4.2.

Writing of D/A Conversion Data

- 1) The input digital data will be converted into analog data and then output to the terminals.
- 2) If data is stored in the special devices, the averaging time can be set, and the output mode can be specified.
- 3) Special auxiliary relays (10 points) and special data registers (10 points) are assigned automatically starting from the adapter nearest the main unit.
 → For a detailed description of special device assignment, refer to Section 4.2.

- FX3U, FX3UC Series PLC

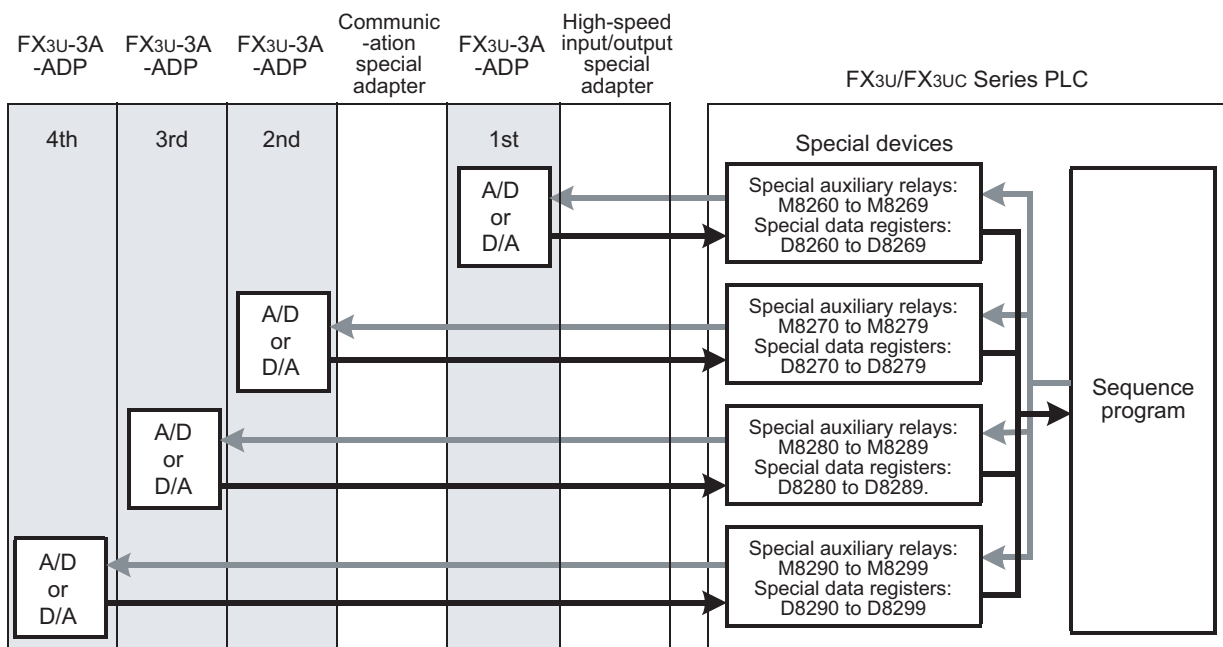

The analog special adapter nearest to the main unit is counted as the 1st analog special adapter, and the next adapter as the 2nd analog special adapter, and so on. However, in this case, do not include the highspeed input/output special adapter, communication special adapter, and the CFcard special adapter.

- FX3G Series PLC

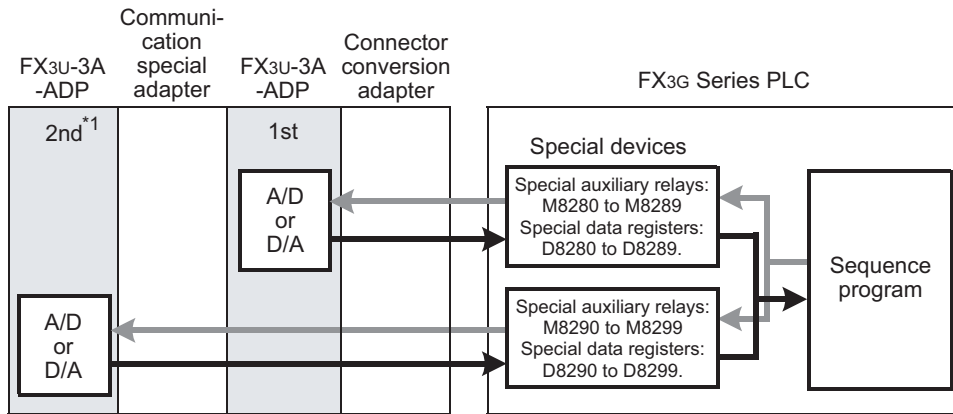

The analog special adapter nearest to the main unit is counted as the 1st analog special adapter, and the next adapter as the 2nd analog special adapter. In this case, however, do not include the connector conversion adapter and the communication special adapter.

*1. The second special adapter is not available in the 14-point and 24-point type FX3G PLC main unit.

4.2 List of Special Devices

If the 3A-ADP is connected, special devices will be assigned automatically as shown in the following table:

- FX3U, FX3UC Series PLC

R: Read / W: Write

Special device	Device number				Description	Attribute	Reference	
	1st	2nd	3rd	4th				
Special auxiliary relay	M8260	M8270	M8280	M8290	Switches the input mode of channel 1	R/W	Section 4.3	
	M8261	M8271	M8281	M8291	Switches the input mode of channel 2	R/W		
	M8262	M8272	M8282	M8292	Switches the output mode.	R/W	Section 4.4	
	M8263	M8273	M8283	M8293	Unused (Do not use.)	-	-	
	M8264	M8274	M8284	M8294				
	M8265	M8275	M8285	M8295				
	Special data register	M8266	M8276	M8286	M8296	Sets the cancel of output holding function.	R/W	Section 4.5
		M8267	M8277	M8287	M8297	Sets whether or not input channel 1 is used.	R/W	Section 4.6
		M8268	M8278	M8288	M8298	Sets whether or not input channel 2 is used.	R/W	
		M8269	M8279	M8289	M8299	Sets whether or not output channel is used.	R/W	Section 4.7
D8260		D8270	D8280	D8290	Channel-1 input data	R		
D8261		D8271	D8281	D8291	Channel-2 input data	R		
D8262		D8272	D8282	D8292	Output setting data	R/W	Section 4.8	
D8263		D8273	D8283	D8293	Unused (Do not use.)	-	-	
D8264		D8274	D8284	D8294	Averaging time for channel-1 (Setting range: 1 to 4095)	R/W	Section 4.9	
D8265		D8275	D8285	D8295	Averaging time for channel-2 (Setting range: 1 to 4095)	R/W		
D8266	D8276	D8286	D8296	Unused (Do not use.)	-	-		
D8267	D8277	D8287	D8297					
D8268	D8278	D8288	D8298	Error status	R/W	Section 4.10		
D8269	D8279	D8289	D8299	Model code = 50	R	Section 4.11		

- FX3G Series PLC

R: Read / W: Write

Special device	Device number		Description	Attribute	Reference
	1st	2nd			
Special auxiliary relay	M8280	M8290	Switches the input mode of channel 1	R/W	Section 4.3
	M8281	M8291	Switches the input mode of channel 2	R/W	
	M8282	M8292	Switches the output mode.	R/W	Section 4.4
	M8283	M8293	Unused (Do not use.)	-	-
	M8284	M8294			
	M8285	M8295			
	M8286	M8296	Sets the cancel of output holding function.	R/W	Section 4.5
	M8287	M8297	Sets whether or not the input channel 1 is used.	R/W	Section 4.6
	M8288	M8298	Sets whether or not the input channel 2 is used.	R/W	
M8289	M8299	Sets whether or not the output channel is used.	R/W		
Special data register	D8280	D8290	Channel-1 input data	R	Section 4.7
	D8281	D8291	Channel-2 input data	R	
	D8282	D8292	Output setting data	R/W	Section 4.8
	D8283	D8293	Unused (Do not use.)	-	-
	D8284	D8294	Averaging time for channel-1 (Setting range: 1 to 4095)	R/W	Section 4.9
	D8285	D8295	Averaging time for channel-2 (Setting range: 1 to 4095)	R/W	
	D8286	D8296	Unused (Do not use.)	-	-
	D8287	D8297			
	D8288	D8298	Error status	R/W	Section 4.10
D8289	D8299	Model code = 50	R	Section 4.11	

4.3 Switching of Input Mode

Turn the special auxiliary relay on/off to switch the input mode of 3A-ADP between the current input mode and the voltage input mode.

To switch the input mode, use the following special auxiliary relays:

- FX3U, FX3UC Series PLC

Special auxiliary relay				Description
1st	2nd	3rd	4th	
M8260	M8270	M8280	M8290	Switches the input mode of channel 1
M8261	M8271	M8281	M8291	Switches the input mode of channel 2

OFF:Voltage input
ON :Current input

- FX3G Series PLC

Special auxiliary relay		Description
1st	2nd	
M8280	M8290	Switches the input mode of channel 1
M8281	M8291	Switches the input mode of channel 2

OFF:Voltage input
ON :Current input

1. Program Example (For FX3U, FX3UC Series PLC)

To switch the channel input mode, create a sequence program as follows:

- 1) To switch the input mode of channel 1 of the 1st analog special adapter to the voltage input mode:

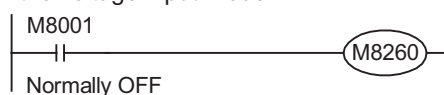

- 2) To switch the input mode of channel 2 of the 1st analog special adapter to the current input mode:



4.4 Switching of Output Mode

Turn the special auxiliary relay on/off to switch the output mode of 3A-ADP between the current output mode and the voltage output mode.

To switch the output mode, use the following special auxiliary relays:

- FX3U, FX3UC Series PLC

Special auxiliary relay				Description
1st	2nd	3rd	4th	
M8262	M8272	M8282	M8292	Switches the output mode OFF: Voltage output ON : Current output

- FX3G Series PLC

Special auxiliary relay		Description
1st	2nd	
M8282	M8292	Switches the output mode OFF: Voltage output ON : Current output

1. Program Example (For FX3U, FX3UC Series PLC)

To switch the output mode of a channel, create a sequence program as follows:

- To switch the channel output mode of channel 1 of the 1st analog special adapter to the voltage output mode:

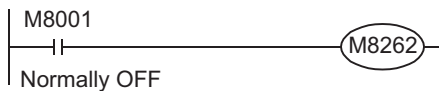

4.5 Output Holding Function Cancellation Setting

This setting can hold the analog data output or to output the offset data (0V for voltage output mode, 4mA for current output mode) when the PLC stops.

To cancel or set the output holding function, use the following special auxiliary relays:

- FX3U, FX3UC Series PLC

Special auxiliary relay				Description
1st	2nd	3rd	4th	
M8266	M8276	M8286	M8296	Cancel output holding function setting OFF: Holds the analog data output just before stop of the PLC. ON : Outputs the offset data at stop of the PLC.

- FX3G Series PLC

Special auxiliary relay		Description
1st	2nd	
M8286	M8296	Cancel output holding function setting OFF: Holds the analog data output just before stop of the PLC. ON : Outputs the offset data at stop of the PLC.

1. Program Example (For FX3U, FX3UC Series PLC)

To set or cancel the output holding function for a channel, create a sequence program as follows:

- To set the output holding function for channel 1 of the 1st analog special adapter:

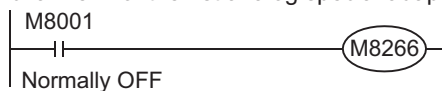

4.6 Setting whether or not a channel is used

The 3A-ADP sets to ON or OFF special auxiliary relays to set whether or not each channel is used. This setting can be used to disable or enable the input or output channels of the 3A-ADP.

- FX3U, FX3UC Series PLCs

Special auxiliary relay				Description
1st	2nd	3rd	4th	
M8267	M8277	M8287	M8297	Sets whether or not input channel 1 is used.
M8268	M8278	M8288	M8298	Sets whether or not input channel 2 is used.
M8269	M8279	M8289	M8299	Sets whether or not output channel is used.

- FX3G Series PLC

Special auxiliary relay		Description
1st	2nd	
M8287	M8297	Sets whether or not input channel 1 is used.
M8288	M8298	Sets whether or not input channel 2 is used.
M8289	M8299	Sets whether or not output channel is used.

POINT

When the setting whether or not the output channel is used is changed from "Used (OFF)" to "Not used (ON)", the last output before the change is held.

1. Program Example (For FX3U, FX3UC Series PLCs)

Set whether or not each channel is used in a sequence program.

- 1) To set that input channel 2 in the 1st unit is not used:

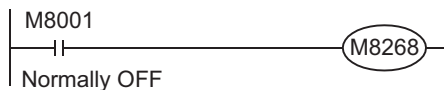

4.7 Input Data

Numeric data type: Decimal (K)

The data converted by the 3A-ADP will be stored in the special data registers.
 The special data registers that store the input data are shown in the following table:

- FX3U, FX3UC Series PLC

Special auxiliary relay				Description
1st	2nd	3rd	4th	
D8260	D8270	D8280	D8290	Stores the channel-1 input data
D8261	D8271	D8281	D8291	Stores the channel-2 input data

- FX3G Series PLC

Special auxiliary relay		Description
1st	2nd	
D8280	D8290	Stores the channel-1 input data
D8281	D8291	Stores the channel-2 input data

The converted A/D immediate data or averaged data (data average conforming to the specified averaging time) will be stored in the above data registers as the input data.

When the channel is not used, "0" will be stored.

→ For a detailed description of the averaging time, refer to Section 4.9.

1. Caution regarding input data

Input data is for reading only.

Do not change (rewrite) the input data using sequence program, indicator, or device monitor of the programming tool.

2. Program Example (For FX3U, FX3UC Series PLC)

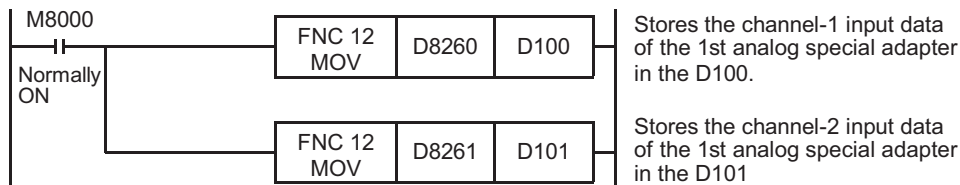

Stores the channel-1 input data of the 1st analog special adapter in the D100.

Stores the channel-2 input data of the 1st analog special adapter in the D101

Even if the input data is not stored in D100 or D101, data registers D8260 or D8261 can be directly used in the timer/counter set value or in a PID instruction.

4.8 Output Setting Data

Numeric data type: Decimal (K)

The 3A-ADP performs D/A conversion on the output setting data (digital data) into analog data, and outputs the analog data.

Use the special data registers shown in the following table for the output setting data:

- FX3U, FX3UC Series PLC

Special auxiliary relay				Description
1st	2nd	3rd	4th	
D8262	D8272	D8282	D8292	Output setting data

- FX3G Series PLC

Special data register		Description
1st	2nd	
D8282	D8292	Output setting data

1. Program Example (For FX3U, FX3UC Series PLC)

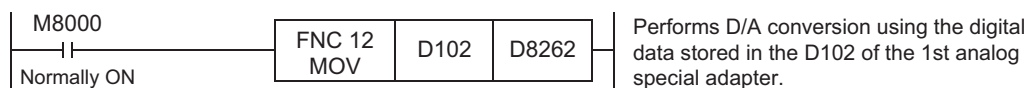

Using the indicator or the sequence program, input the digital data to be subject to D/A conversion (to be output as analog data) in D102.

4.9 Averaging Time

Setting range: 1 to 4095

Initial value: K1

Numeric data type: Decimal (K)

If the averaging time is set for the 3A-ADP, the average data will be stored as the input data. The averaging time can be set for each channel.

Set the averaging time in the following special data registers:

- FX3U, FX3UC Series PLC

Special auxiliary relay				Description
1st	2nd	3rd	4th	
D8264	D8274	D8284	D8294	Averaging time for channel-1 data
D8265	D8275	D8285	D8295	Averaging time for channel-2 data

- FX3G Series PLC

Special data register		Description
1st	2nd	
D8284	D8294	Averaging time for channel-1 data
D8285	D8295	Averaging time for channel-2 data

1. Cautions regarding averaging time setting

- If the averaging time is set to "1", the immediate data is stored to the special data register.
- If the averaging time is set in the range from 2 to 4095, the average value will be calculated to conform to the set averaging time, and the average value obtained will be stored in the special data register.
- After turning the PLC power on, the current data is stored to special data registers until the number of data items reaches the set averaging time. After this, the average data will be stored.
- Set the averaging time in the range from 1 to 4095. If the set value is outside the setting range, an error signal will be output.
- If the averaging time is set to "0" or smaller, the PLC will perform as if the averaging time is set to "1".
 If the averaging time is set to "4096" or larger, the PLC will perform as if the averaging time is set to "4096".
 → For a detailed description of the error status, refer to Section 6.5.

2. Program Example (For FX3U, FX3UC Series PLC)

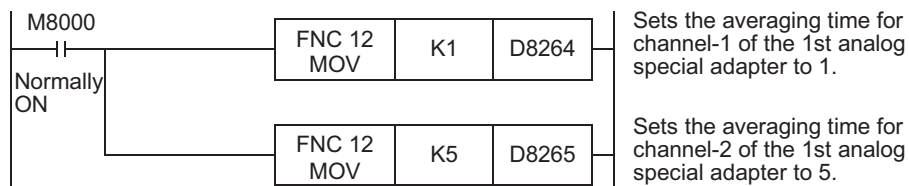

Sets the averaging time for channel-1 of the 1st analog special adapter to 1.

Sets the averaging time for channel-2 of the 1st analog special adapter to 5.

4.10 Error Status

If an error is detected in the 3A-ADP, the error status data will be stored in the corresponding special data register.

The following table shows the special data registers that store the error status data:

- FX3U, FX3UC Series PLC

Special auxiliary relay				Description
1st	2nd	3rd	4th	
D8268	D8278	D8288	D8298	Stores the error status data.

- FX3G Series PLC

Special data register		Description
1st	2nd	
D8288	D8298	Stores the error status data.

Check the ON/OFF status of each bit of the error status data register to check the description of the error. Errors are assigned to the bits as shown in the following table. Create a program to detect errors.

→ For a detailed description of the error status, refer to Section 6.5.

Bit	Description	Bit	Description
b0	Channel-1 over-scale detection	b6	3A-ADP hardware error (Power supply error included) ^{*1}
b1	Channel-2 over-scale detection	b7	3A-ADP communication data error ^{*2}
b2	Output data setting error	b8	Channel-1 under-scale detection ^{*3}
b3	Unused	b9	Channel-2 under-scale detection ^{*3}
b4	EEPROM error	b10 to b15	Unused
b5	Averaging time setting error	-	-

- *1. A 3A-ADP hardware error (b6) is valid only when the use of analog input is set. Detection of power supply error is valid only when the use of analog input channel 2 is set.
- *2. A 3A-ADP communication data error (b7) is valid only when the use of analog input is set.
- *3. The FX3U/FX3UC Series PLC Ver.2.70 or later supports the under-scale detection function. The under-scale detection function is valid only for current input mode.

1. Caution regarding use of error status data

If a 3A-ADP hardware error (b6) or 3A-ADP communication data error (b7) is detected, it is necessary to clear the error status with a program at the next power-on of the PLC.

For this reason, be sure to create the following program:

- FX3G, FX3U, FX3UC Series PLC

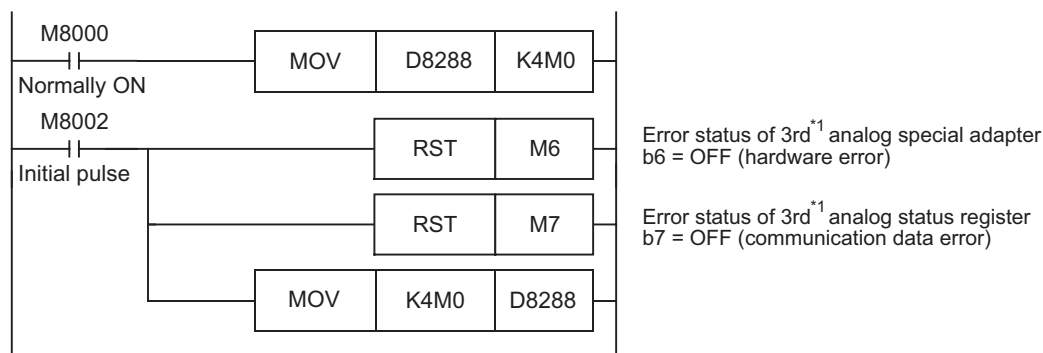

- *1. "1st" for the FX3G PLC.

- FX3U, FX3UC Series PLC

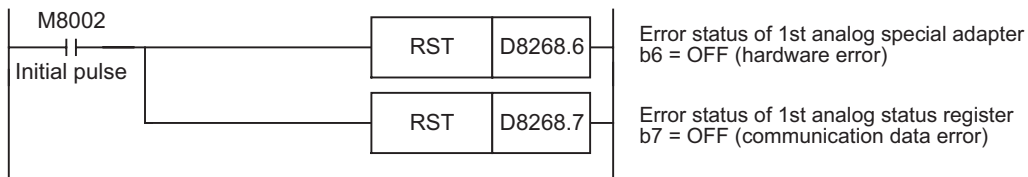

2. Program Example 1 (FX3G, FX3U, FX3UC Series PLC)

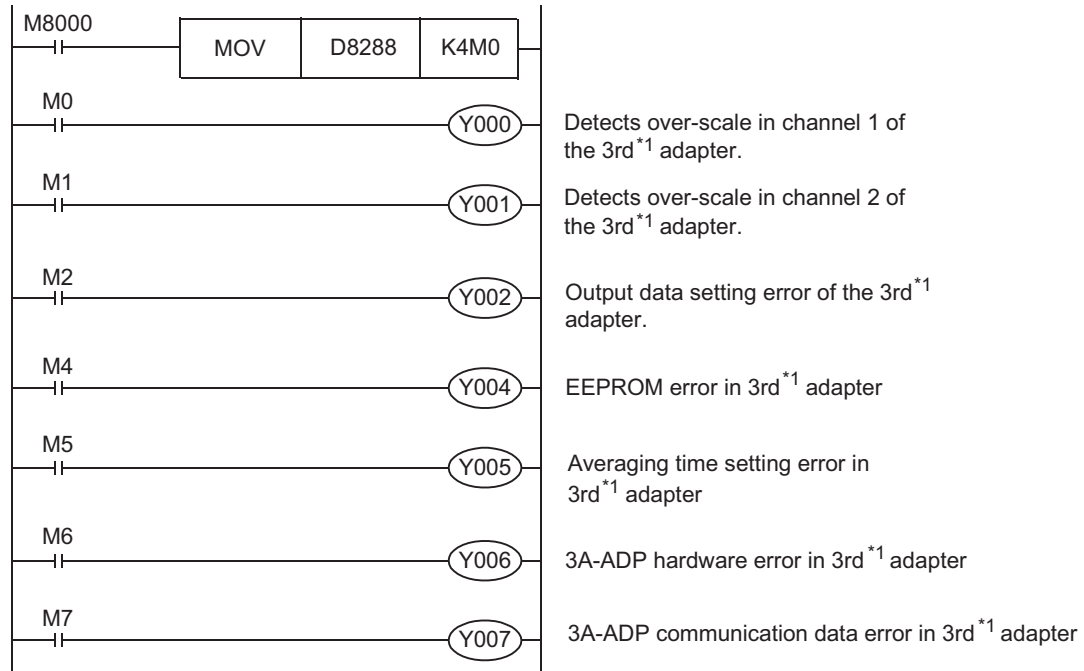

*1. "1st" for the FX3G PLC.

3. Program Example 2 (FX3U, FX3UC Series PLC)

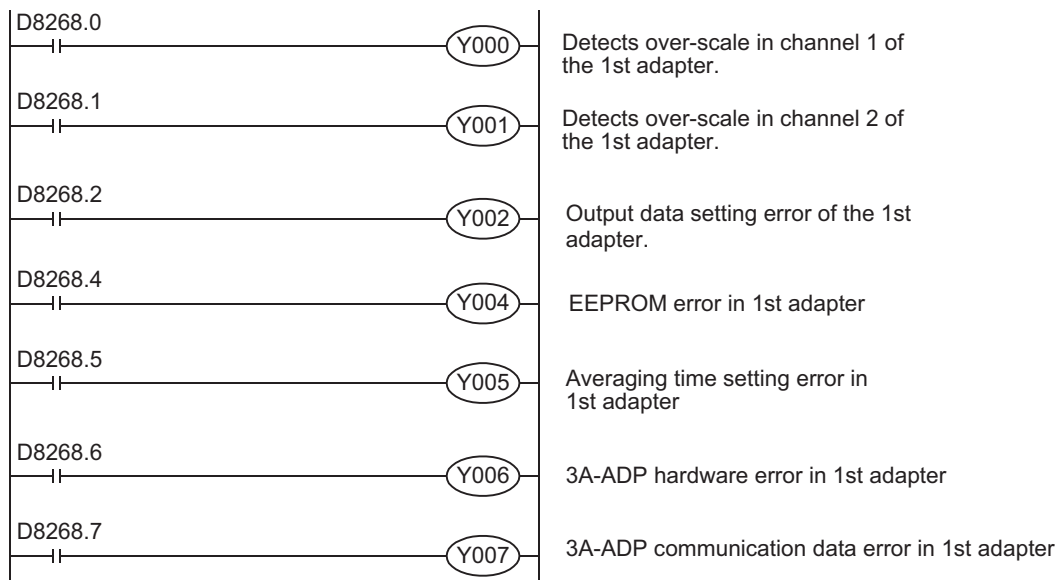

A	Common Items
B	FX3U-4AD FX3UC-4AD
C	FX3U-4AD-ADP
D	FX3G-2AD-BD
E	FX3U-4DA
F	FX3U-4DA-ADP
G	FX3G-1DA-BD
H	FX3U-3A-ADP
I	FX3U-4AD-PT -ADP
J	FX3U-4AD-PTW -ADP

4.11 Model Code

Initial value: K50
Numeric data type: Decimal (K)

When the 3A-ADP is connected, model code "50" is stored in the corresponding special data register.
 The following table shows the special data registers that store the model code:

- FX3U, FX3UC Series PLC

Special auxiliary relay				Description
1st	2nd	3rd	4th	
D8269	D8279	D8289	D8299	Model code

- FX3G Series PLC

Special data register		Description
1st	2nd	
D8289	D8299	Model code

Use the special data registers above to check whether a 3A-ADP is connected or not.

1. Program Example (FX3u, FX3uc Series PLC)

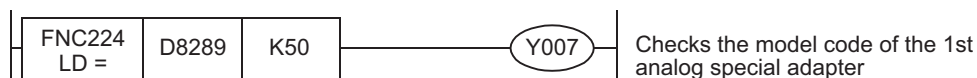

4.12 Basic Program Example

Create the following basic program example to input/output analog conversion data.

- FX3G, FX3U, FX3UC Series PLC

The following program will set channel 1 of the 3rd^{*1} adapter to voltage input mode and channel 2 to current input mode, and will store the converted A/D value of channel-1 data into D100 and that of channel-2 data into D101. The program also sets "voltage output" for output channels, and sets the D/A conversion output to D102.

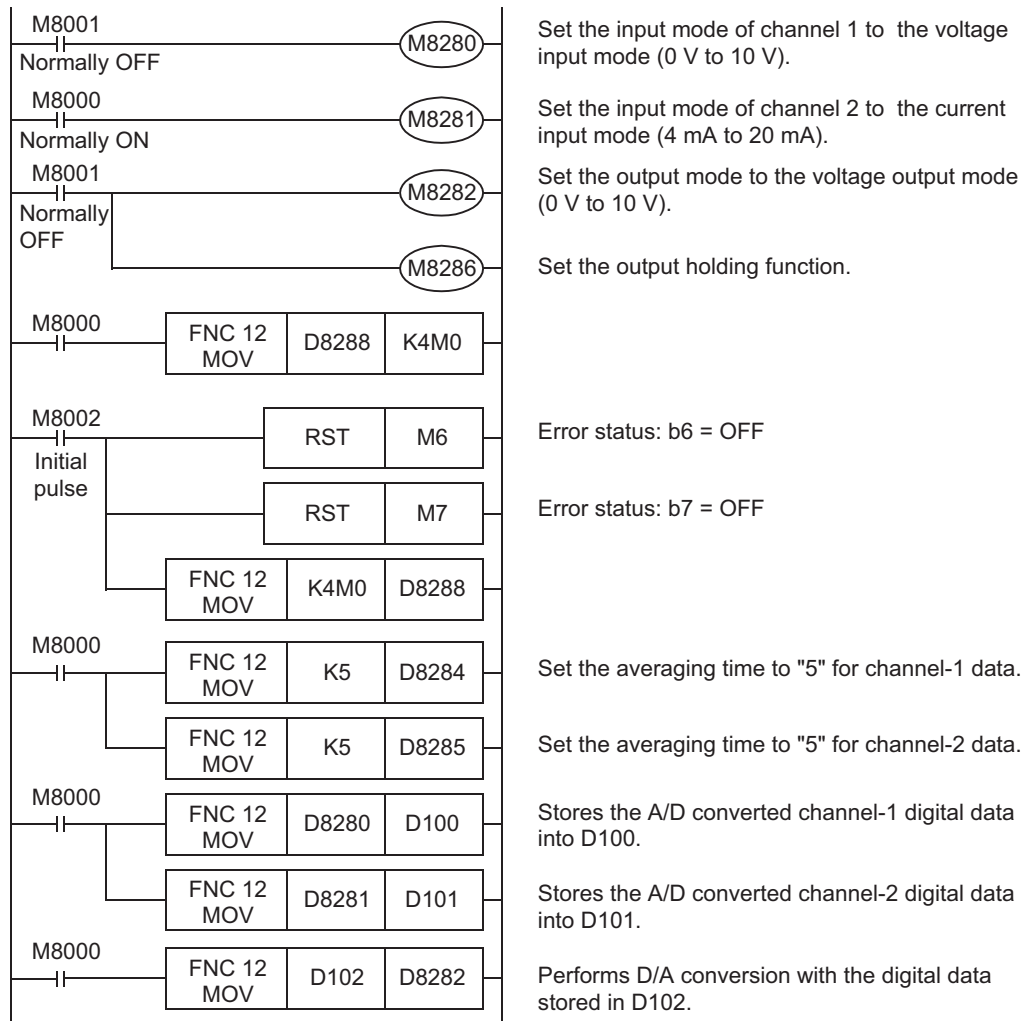

Even if the input data is not stored into D100 or D101, the data registers D8280 or D8281 can be directly used in the timer/counter setting value or in a PID instruction.

Using the indicator or the sequence program, input the digital data to be subject to D/A conversion (to be output as analog data) in D102.

*1. "1st" for the FX3G PLC.

• FX3U, FX3UC Series PLC

The following program will set channel 1 of the 1st adapter to voltage input mode and channel 2 to current input mode, and will store the converted A/D value of channel-1 data into D100 and that of channel-2 data into D101. The program will also set "voltage output" for output channels, and set the digital D/A conversion output to D102.

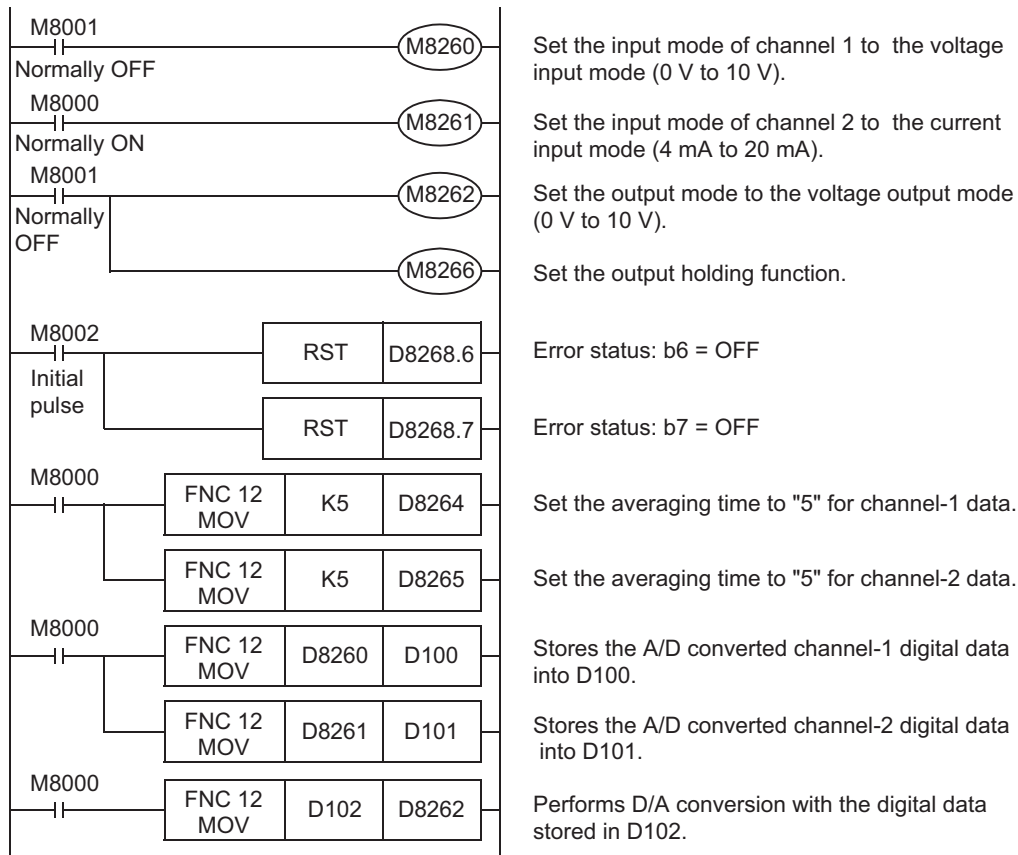

Even if the input data is not stored into D100 or D101, the data registers D8260 or D8261 can be directly used in the timer/counter setting value or in a PID instruction.

Using the indicator or the sequence program, input the digital data to be subject to D/A conversion (to be output as analog data) in D102.

5. Changing of Input/output Characteristics

Use the scaling instruction (SCL/FNC 259) for the FX3U/FX3UC Series PLC to change the input/output characteristics. FX3G Series PLCs do not support the scaling instruction. Use sequence programs to change the input/output characteristics.

→ For a detailed description of scaling instruction, refer to the **FX3G/FX3U/FX3UC Series Programming Manual - Basic & Applied Instruction Edition**.

5.1 Example: Changing of Voltage Input Characteristics

This section describes an example of a program that can change the digital output range of 400 to 2000 (when the voltage input is 1 to 5V) to the digital output range of 0 to 10000.

1. Input characteristics

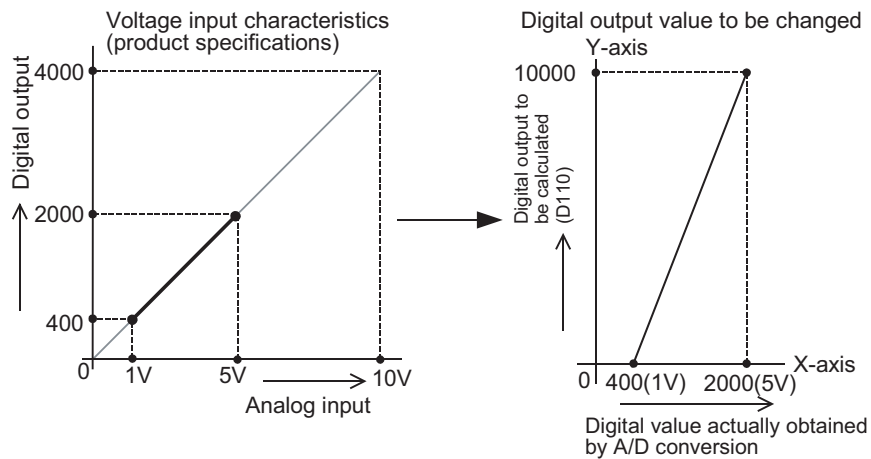

2. Example of program 1 (FX3U, FX3UC Series PLC)

- For example, create the following program to change the digital input data of the 1st analog special adapter:

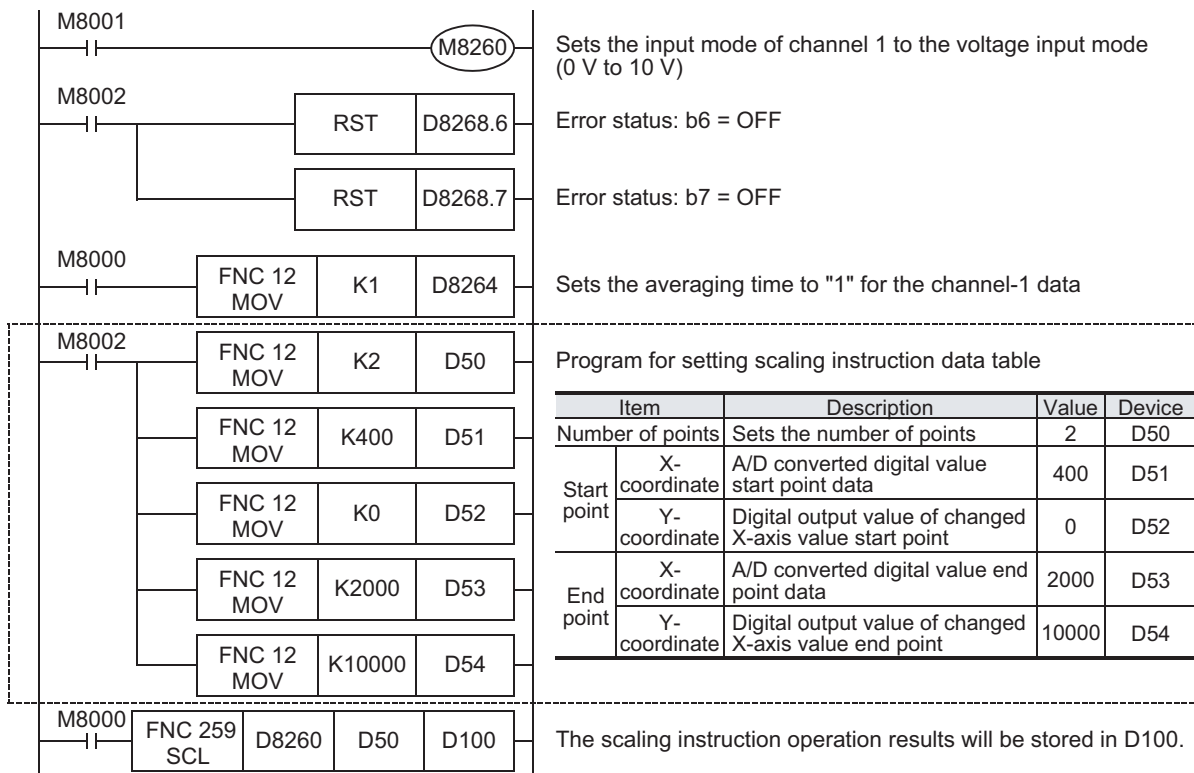

3. Example of program 2 (FX3G Series PLC)

- For example, create the following program to change the digital input data (D110) of the 1st analog special adapter:

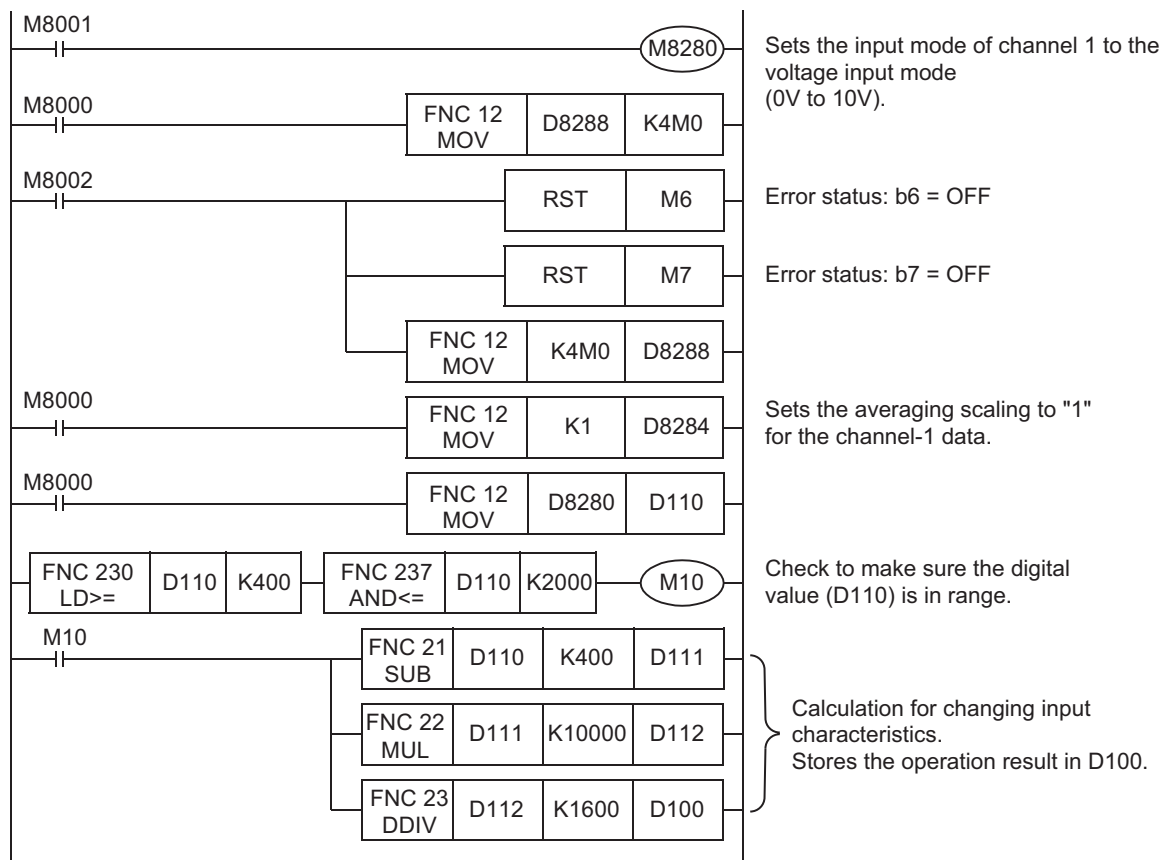

4. Cautions regarding programming

- GX Developer version 8.13P or later supports scaling instruction (SCL/FNC 259).
- If the A/D converted digital value is out of the data table range specified by the scaling instruction (SCL/FNC 259), the FX Series PLC will detect an operation error (error code: K6706).

A Common Items

B FX3U-4AD
FX3UC-4AD

C FX3U-4AD-ADP

D FX3G-2AD-BD

E FX3U-4DA

F FX3U-4DA-ADP

G FX3G-1DA-BD

H FX3U-3A-ADP

I FX3U-4AD-PT
-ADP

J FX3U-4AD-PTW
-ADP

5.2 Example: Changing of Voltage Output Characteristics

This section describes an example of a program that can change the digital value range from 400 to 2000 (when analog output range is 1 to 5V) to 0 to 10000. A specified digital value is inputted into D120.

1. Output characteristics

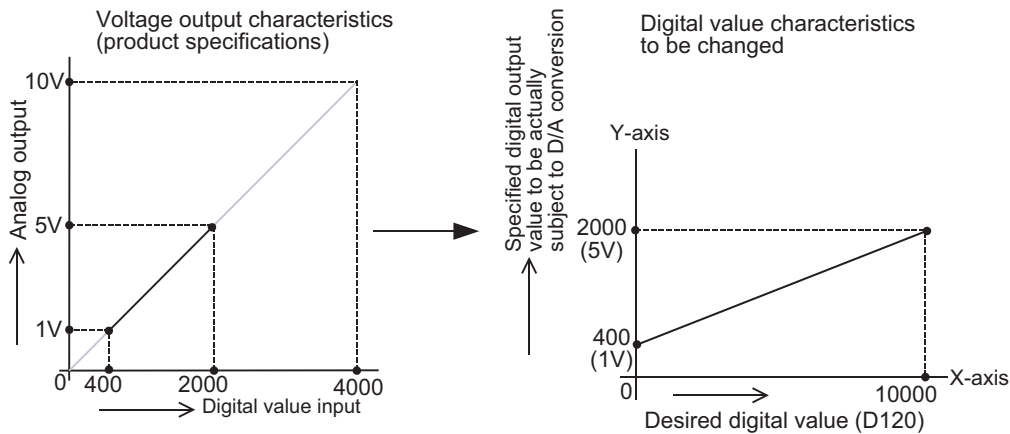

2. Example of program 1 (FX3U, FX3UC Series PLC)

- For example, create the following program to change the digital output of the 1st analog special adapter.

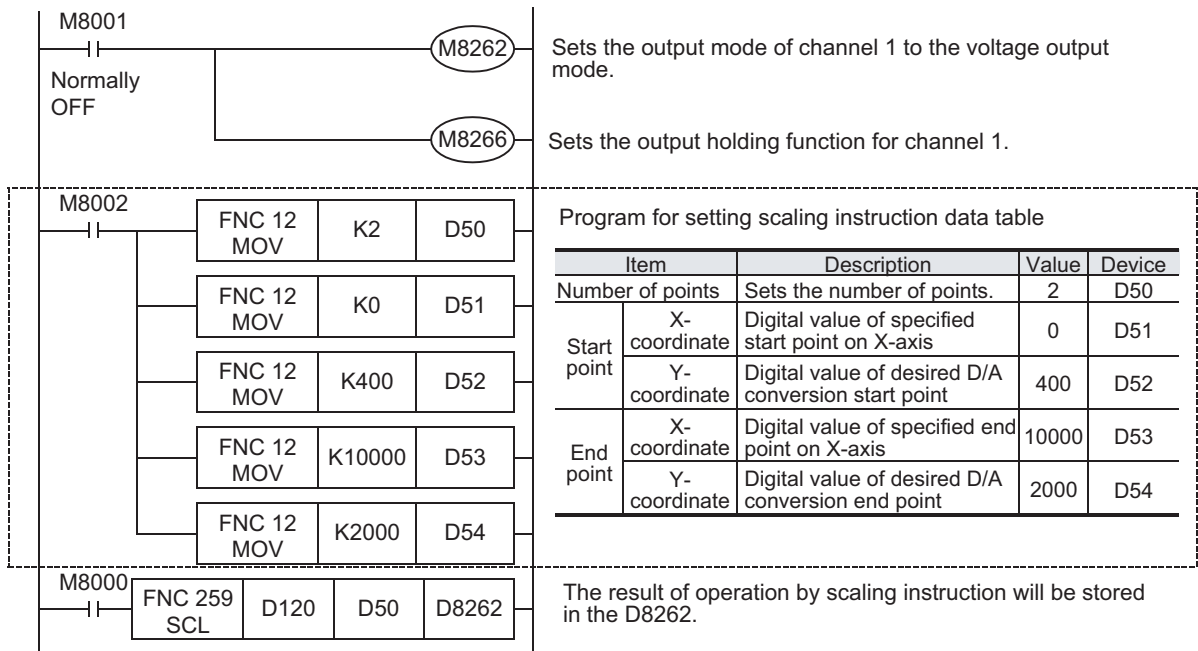

3. Example of program 2 (FX3G Series PLC)

- For example, create the following program to change the digital output data (D120) of the 1st analog special adapter.

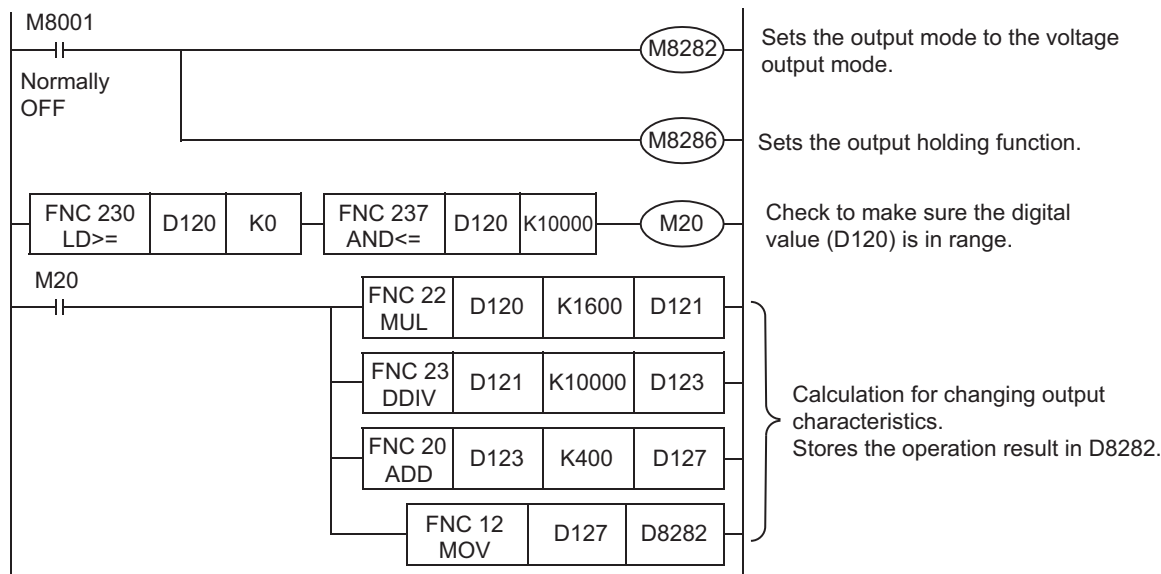

4. Cautions regarding programming

- GX Developer version 8.13P or later supports scaling instruction (SCL/FNC259).
- If the input digital value for the D/A conversion is out of the data table range specified by scaling instruction (SCL/FNC259), the FX Series PLC will detect an operation error (error code: K6706).

A
Common Items

B
FX3U-4AD
FX3UC-4AD

C
FX3U-4AD-ADP

D
FX3G-2AD-BD

E
FX3U-4DA

F
FX3U-4DA-ADP

G
FX3G-1DA-BD

H
FX3U-3A-ADP

I
FX3U-4AD-PT-ADP

J
FX3U-4AD-PTW-ADP

6. Troubleshooting

This chapter describes troubleshooting methods and error statuses.

Refer to the following items when conversion data is not input or output, or when proper digital values are not input or output.

- PLC version number
- Installation
- Wiring
- Special devices
- Programs
- Error status

6.1 PLC Version Number Check

- Check the version number of the FX3U, FX3UC Series PLC. The version number should be 2.61 or later.
- Check the version number of the FX3G Series PLC. The version number should be 1.20 or later.
→ For a detailed description of the version number check method, refer to Section 1.3.

6.2 Wiring Check

Check the following items for wiring:

1. Power

The 3A-ADP needs driving power. Verify that the power supply line is properly connected. Also check that the POWER indicator lamp of the 3A-ADP is on.

2. Analog input/output line

Use 2-core twisted shielded pair cable for the analog input/output line. In addition, be sure to separate the analog input line from other power lines or inductive lines.

3. Use of current input mode

To use the current input mode for a channel, be sure to shortcircuit the line between the V□+ terminal and the I□+terminal (□: channel number) of the channel. If the line is not shortcircuited, data will not be converted into proper digital data.

→ For a detailed description of wiring, refer to Chapter 3.

6.3 Special Device Check

Check whether the special devices for the 3A-ADP are being used correctly:

1. Input mode switching

Check that the special device for switching the input mode is set correctly.

Turn off the device to set the input mode to the voltage input mode. Turn on the device to set the input mode to the current input mode.

2. Output mode switching

Verify that the special device for switching the output mode is correctly set.

Turn off the device to set the output mode to the voltage output mode. Turn on the device to set the output mode to the current output mode.

3. Input data

Verify that the special device of the selected channel is correctly selected. This special device should be selected depending on the connecting position and the channel.

4. Output setting data

Check that the special device of the selected channel is correctly selected. This special device should be selected depending on the connected position and the channel.

5. Averaging time

Check that the set averaging time is within the specified range. The averaging time should be set in the range from 1 to 4095. If the set averaging time is outside the specified range, an error occurs.

6. Setting whether or not each channel is used

Check whether each channel is set correctly.

Set a channel to OFF when using it. Set a channel to ON when not using it.

7. Error status

Check that no error is detected in the 3A-ADP.

If an error is detected, check the details of the error, and then check the wiring and programs.

→ For a detailed description of special devices, refer to Chapter 4.

6.4 Program Check

Check the following items for the program:

1. Clearing of error status at power on

When the power is turned off and then on again, the error status should be cleared (b6 and b7 should turn off) using the program.

2. Check of storage devices

Verify that different values are not being stored in the same device by other parts of the program.

3. Device for setting specified digital value

Check that different values are not written to this device using other programs.

6.5 Error Status Check

If an error occurs in the 3A-ADP, the corresponding bit will turn ON.

The bit which is turned ON due to the error status is held ON until overwritten to OFF by the program or the power is cycled. If b6 or b7 is turned ON, then it is necessary to clear the error status using the program the next time the power of the PLC is cycled.

Bit	Description	Bit	Description
b0	Channel-1 over-scale detection	b6	3A-ADP hardware error (Power supply error included)*1
b1	Channel-2 over-scale detection	b7	3A-ADP communication data error*2
b2	Output data setting error	b8	Channel-1 under-scale detection*3
b3	Unused	b9	Channel-2 under-scale detection*3
b4	EEPROM error	b10 to b15	Unused
b5	Averaging time setting error	-	-

*1. 3A-ADP hardware error (b6) is valid only when use of analog input is set.

Detection of power supply error is valid only when use of the analog input channel 2 is set.

*2. 3A-ADP communication data error (b7) is valid only when use of analog input is set.

*3. The FX3U/FX3UC Series PLC Ver.2.70 or later supports the under-scale detection function. The under-scale detection function is valid only for current input mode.

To solve the problem, refer to the troubleshooting method described below:

1. Over-scale detection (b0, b1)

1) Description of error

The input analog value (voltage or current value) is outside the specified range.

Voltage input mode : The input voltage value is over the specified upper limit of 10.2 V.

Current input mode : The input current value is over the specified upper limit of 20.4 mA.

2) Remedy

Check that the input analog value is within the specified range. Also check the wiring.

2. Output data setting error (b2)

1) Description of error

The specified digital value is outside the specified range.

Analog data will not be correctly output.

2) Remedy

Check that the specified digital value is within the specified range.

3. EEPROM error (b4)

1) Description of error

The adjustment data which was set in the EEPROM before delivery from our factory cannot be read out properly or has been destroyed.

2) Remedy

Please contact the nearest Mitsubishi Electric distributor office.

4. Averaging time setting error (b5)

1) Description of error

The averaging time set for one of the channels (channels 1 to 2) is outside the specified range: 1 to 4095.

2) Remedy

Check that the averaging time is set correctly for each channel.

5. 3A-ADP hardware error (b6)

1) Description of error

The 3A-ADP is not operating properly.

2) Remedy

Check that the 3A-ADP is correctly connected to the PLC.

If the problem cannot be solved even after the above check, please contact the nearest Mitsubishi Electric distributor office.

6. 3A-ADP communication data error (b7)

1) Description of error

A communication error is detected between the 3A-ADP and the PLC.

2) Remedy

Check that the 3A-ADP is correctly connected to the PLC.

If the problem cannot be solved even after the above check, please contact the nearest Mitsubishi Electric distributor office.

7. Under-scale detection (b8, b9)

1) Description of error

The input analog value (current value) is below the specified lower limit.

This error is only detected for the current input mode, and indicates the input current is less than 2 mA.

2) Remedy

Check that the input analog value is within the specified range. Also check the wiring.

FX3G/FX3U/FX3UC Series Programmable Controllers

User's Manual [Analog Control Edition]

FX3U-4AD-PT-ADP

(4-channel Platinum Resistance Thermometer Data Input)

Foreword

This manual describes the specifications, wiring, and operation methods for the FX3U-4AD-PT-ADP special adapter (4-channel platinum resistance thermometer input) and should be read and understood before attempting to install or use the unit.

Store this manual in a safe place so that you can take it out and read it whenever necessary. Always forward it to the end user.

This manual confers no industrial property rights or any rights of any other kind, nor does it confer any patent licenses. Mitsubishi Electric Corporation cannot be held responsible for any problems involving industrial property rights which may occur as a result of using the contents noted in this manual.

© 2005 MITSUBISHI ELECTRIC CORPORATION

A
Common Items

B
FX3U-4AD
FX3UC-4AD

C
FX3U-4AD-ADP

D
FX3G-2AD-BD

E
FX3U-4DA

F
FX3U-4DA-ADP

G
FX3G-1DA-BD

H
FX3U-3A-ADP

I
FX3U-4AD-PT-ADP

J
FX3U-4AD-PTW-ADP

1. Outline

This chapter describes the outline of FX3U-4AD-PT-ADP (referred to as PT-ADP).

1.1 Outline of Functions

The FX3U-4AD-PT-ADP is an analog special adapter. Connect the FX3U-4AD-PT-ADP to the FX3U/FX3UC/FX3G Series PLC to read the temperature data from the 4-channel platinum resistance thermometers.

- 1) Up to 4 PT-ADP units can be connected to the FX3U/FX3UC Series PLC.
 Up to 2*¹ PT-ADP units can be connected to the FX3G Series PLC.
 (including other analog special adapters)
- 2) After connection of the platinum resistance thermometer (Pt100), measurement of temperature will be possible.
- 3) The temperature measurement data will be automatically written to the special data registers of the FX3U/FX3UC/FX3G Series PLC.

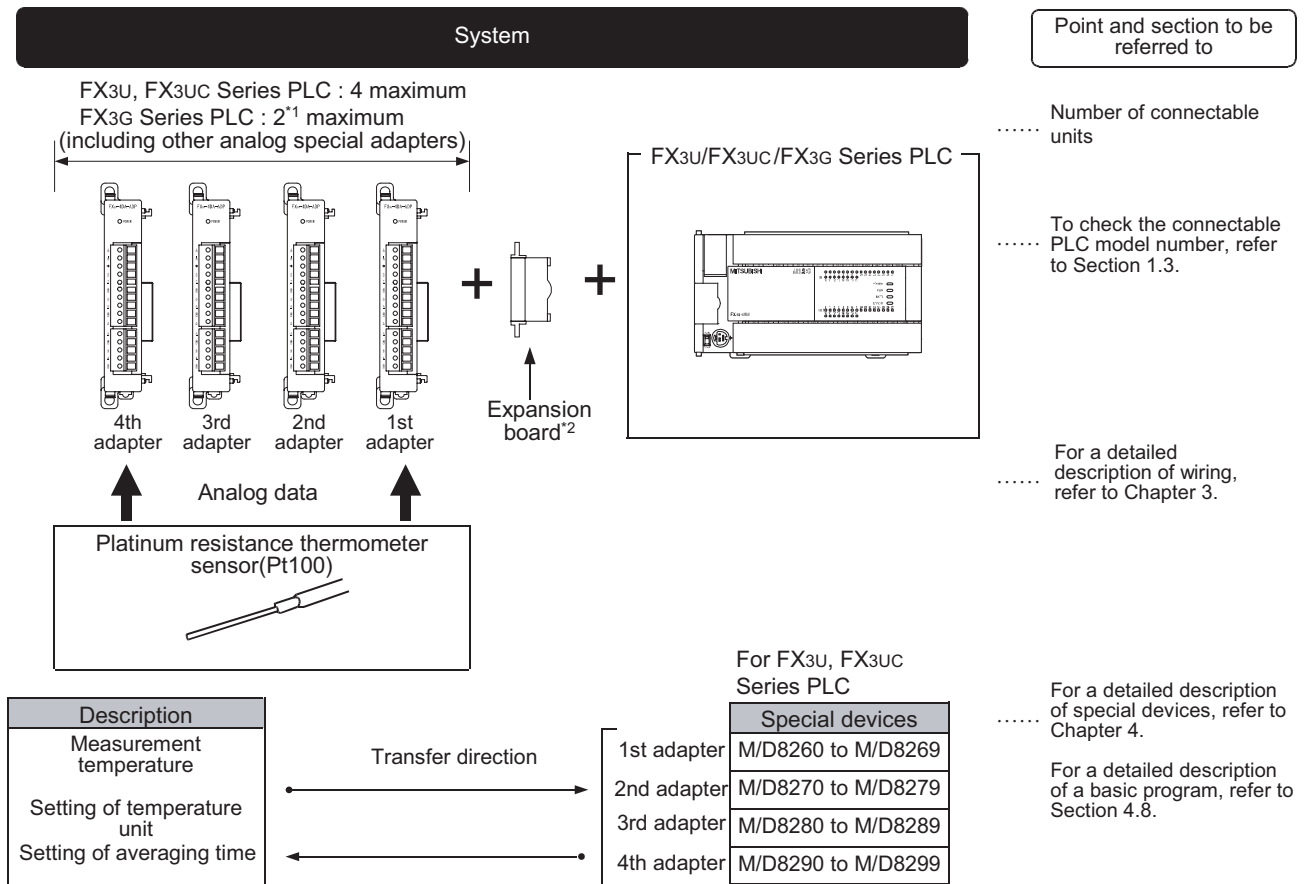

Refer to the system configuration shown in the User's Manual - Hardware Edition to check the number of connectable units and to configure the entire system.

*1. Only 1 analog special adapter can be connected to the 14-point and 24-point type main unit.

*2. The expansion board is not required when connecting with the FX3UC (D, DSS) PLC.
 For the FX3G Series PLC a connector conversion adapter is used.

A Common Items

B FX3U-4AD
FX3UC-4AD

C FX3U-4AD-ADP

D FX3G-2AD-BD

E FX3U-4DA

F FX3U-4DA-ADP

G FX3G-1DA-BD

H FX3U-3A-ADP

I FX3U-4AD-PT-ADP

J FX3U-4AD-PTW-ADP

1.2 Setup Procedure Before Starting Operation

Before starting analog input using the PT-ADP, follow the procedure below to set up the system:

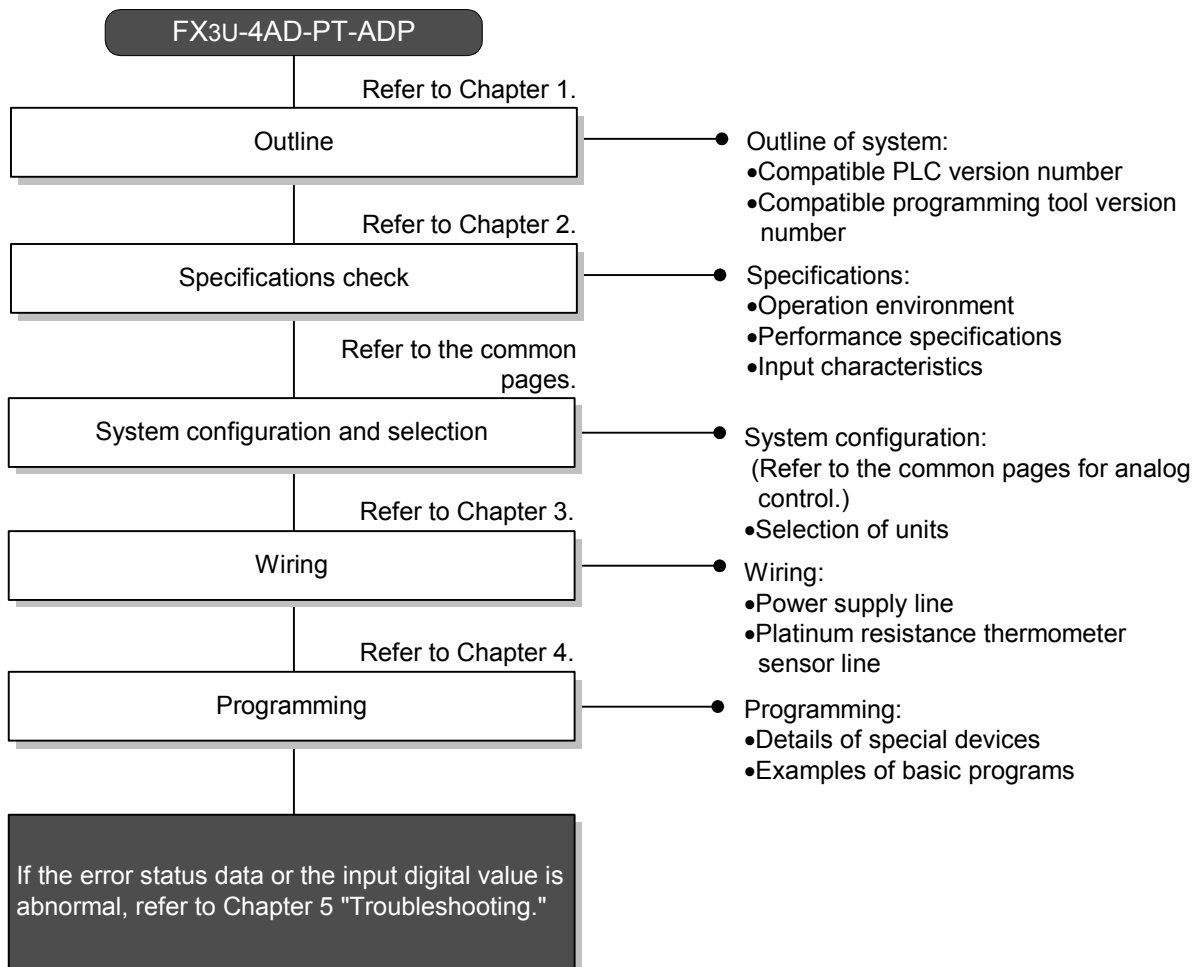

1.3 Connectable PLC and Its Version Number

PT-ADP is compatible with the following PLC.

Compatible PLC	Version number	Date of production
FX3U Series PLC	Ver. 2.20 or later	After May 2005 (initial production)
FX3UC Series PLC	Ver. 1.30 or later	After August 2004
FX3G Series PLC	Ver. 1.00 or later	After June 2008 (initial production)

1. Version check

Special data register D8001 contains information for determining the PLC version.

→ For a detailed description of the version check, refer to A. Common Items Subsection 5.1.2.

2. How to check the manufacturer's serial number

The year and month of production of the product can be checked on the nameplate, and on the front of the product.

→ For a detailed description of how to check the manufacturer's serial number, refer to A. Common Items Subsection 5.1.1.

1.4 Compatible Programming Tool Version Number

Use the programming tool with the following version number to create programs for PT-ADP of the FX3U/FX3UC/FX3G Series PLC:

1. GX Works2

Software	Version number	Remarks
GX Works2 SW□DNC-GXW2-J	Ver. 1.07H or later	-
GX Works2 SW□DNC-GXW2-E	Ver. 1.08J or later	-

2. GX Developer

- FX3U/FX3UC Series PLC

Software	Version number	Remarks
GX Developer SW□D5C-GPPW-J	Ver. 8.13P or later	When selecting the model, select FX3U(C)*1.
GX Developer SW□D5C-GPPW-E	Ver. 8.18U or later	

- FX3G Series PLC

Software	Version number	Remarks
GX Developer • SW□D5C-GPPW-J • SW□D5C-GPPW-E	Ver. 8.72A or later	-

If a programming tool with the wrong version number is used, programming will not be possible.

*1. For Ver. 8.13P to 8.24A of GX Developer, select FX3UC for the PLC type.

3. FX-30P

Model name	Version number	Remarks
FX-30P	Ver. 1.00 or later	-

2. Specifications

This chapter describes the general, power supply, and performance specifications for the PT-ADP.

2.1 Generic Specifications

Item	Specifications				
Ambient temperature	0 to 55°C (32 to 131°F) when operating -25 to 75°C (-13 to 167°F) when stored				
Relative humidity	5 to 95%RH (no condensation) when operating				
Vibration resistance *1	DIN Rail Mounting	Frequency (Hz)	Acceleration (m/s ²)	Half amplitude (mm)	Tested 10 times in each direction (X-, Y-, and Z-axis directions) (Total: 80 min, each)
		10 - 57	-	0.035	
	Direct Mounting *2	57 - 150	4.9	-	
		10 to 57	-	0.075	
		57 to 150	9.8	-	
Shock resistance *1	147 m/s ² Acceleration, Action time: 11ms, 3 times by half-sine pulse in each direction X, Y, and Z				
Noise resistance	Using noise simulator of: Noise voltage: 1,000Vp-p / Noise width: 1μs / Rise: 1ns / Cycle: 30 to 100Hz				
Dielectric withstand voltage	500 V AC, for 1 min		Between all terminals and ground terminal		
Insulation resistance	5MΩ or more using 500V DC insulation resistance meter				
Grounding	Class D grounding (grounding resistance: 100 Ω or less) <Common grounding with a heavy electrical system is not allowed.>*3				
Working environment	Free from corrosive or flammable gas and excessive conductive dusts				
Working altitude	< 2000m*4				

*1. The criterion is shown in IEC61131-2.

*2. If PT-ADP is connected to the FX3UC Series PLC, direct installation is not possible.

*3.

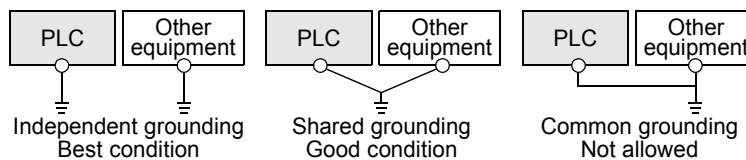

→ For a detailed description of the grounding, refer to Section 3.6.

*4. If the pressure is higher than the atmospheric pressure, do not use the PT-ADP.
 The PT-ADP may malfunction.

2.2 Power Supply Specifications

Items	Specification
A/D conversion circuit driving power	24V DC +20% -15%, 50mA (It is necessary to connect a 24V DC power supply to the terminal block.)
Interface driving power	5V DC, 15mA (Since the internal power is supplied from the FX Series main unit, it is not necessary to supply the power.)

2.3 Performance Specifications

Items	Specifications	
	Centigrade (°C)	Fahrenheit (°F)
Input signal	3-wire platinum resistance thermometer sensor Pt100 JIS C 1604-1997	
Rated temperature range	-50°C to +250°C	-58°F to +482°F
Digital output	-500 to +2500	-580 to +4820
Resolution	0.1°C	0.18°F
Total accuracy	<ul style="list-style-type: none"> ±0.5% for full scale (when ambient temperature is 25°C±5°C) ±1.0% for full scale (when ambient temperature is in the range from 0 to 55°C) 	
A/D conversion time	<ul style="list-style-type: none"> FX3U/FX3UC Series PLC : 200μs (The data will be updated at every scan time.) FX3G Series PLC : 250μs (The data will be updated at every scan time.) →For a detailed description of data update, refer to Section 2.4.	
Input characteristics		
Insulation method	<ul style="list-style-type: none"> The photocoupler is used to insulate the analog input area from the PLC. The DC/DC converter is used to insulate the power supply line from the analog input area. Channels are not insulated from each other. 	
Number of I/O points occupied	0 points (This number is not related to the maximum number of input/output points of the PLC.)	

A
Common Items

B
FX3U-4AD
FX3UC-4AD

C
FX3U-4AD-ADP

D
FX3G-2AD-BD

E
FX3U-4DA

F
FX3U-4DA-ADP

G
FX3G-1DA-BD

H
FX3U-3A-ADP

I
FX3U-4AD-PT-ADP

J
FX3U-4AD-PTM-ADP

2.4 A/D Conversion Time

This section describes the A/D conversion time.

2.4.1 When connected to a FX3U, FX3UC PLC

1. A/D conversion and special data register update timing

A/D conversion is performed at every scan time of the PLC.

During execution of END instruction, the PLC performs A/D conversion, reads out the A/D converted data, and then writes the data in the special data registers.

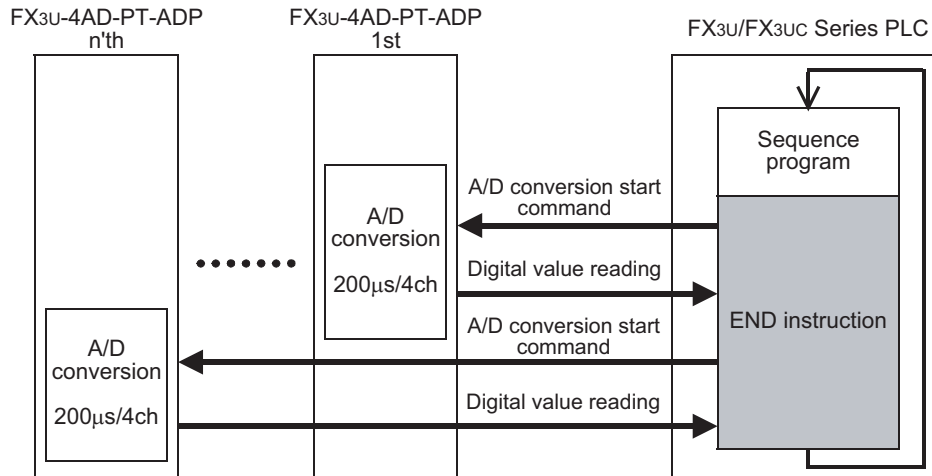

2. A/D conversion during PLC stop

Even if the PLC is stopped, A/D conversion will be performed and the special data registers will be updated.

3. If two or more analog special adapters are connected

During execution of the END instruction, data will be read out from all the connected adapters (in the order of 1st adapter → 2nd adapter ... 4th adapter).

4. A/D conversion speed (data update time)

During execution of the END instruction, the A/D converted data of all 4 channels will be read out in 200µs, and the data read out will be written to the special data registers.

END instruction execution time will be "200µs × number of connected adapters."

2.4.2 When connected to a FX3G PLC

1. A/D conversion and special data register update timing

A/D conversion is performed at every scan time of the PLC.

During execution of END instruction, the PLC performs A/D conversion, reads out the A/D converted data, and then writes the data in the special data registers.

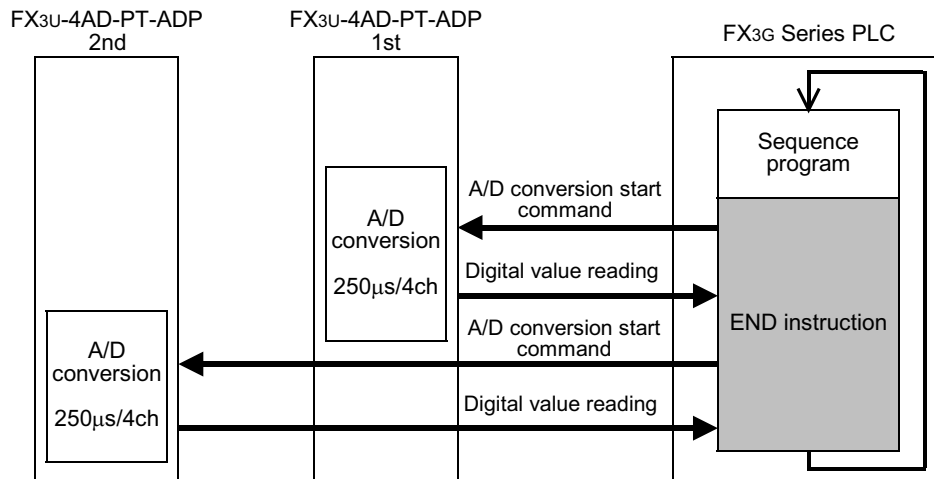

2. A/D conversion during PLC stop

Even if the PLC is stopped, A/D conversion will be performed and the special data registers will be updated.

3. If two analog special adapters are connected

During execution of the END instruction, data will be read out from all the connected adapters (in the order of 1st adapter → 2nd adapter).

4. A/D conversion speed (data update time)

During execution of the END instruction, the A/D converted data of all 4 channels will be read out in 250μs, and the data read out will be written to the special data registers.

END instruction execution time will be "250μs × number of connected adapters."

2.5 Temperature Measurement

To stabilize the temperature measurement, warm-up the system for 30 minutes or more after power-on.

3. Wiring

This chapter describes the PT-ADP wiring.
Observe the following caution to wire the PT-ADP.

WIRING PRECAUTIONS



DANGER

- Make sure to cut off all phases of the power supply externally before attempting wiring work. Failure to do so may cause electric shock or damages to the product.

WIRING PRECAUTIONS



CAUTION

- Connect the DC power supply wiring to the dedicated terminals described in this manual. If an AC power supply is connected to a DC input/output terminal or DC power supply terminal, the PLC will be burnt out.
- Do not wire vacant terminals externally. Doing so may damage the product.
- Perform class D grounding (grounding resistance: 100Ω or less) to the grounding terminal on the main unit. Do not use common grounding with heavy electrical systems.
- When drilling screw holes or wiring, make sure cutting or wire debris does not enter the ventilation slits. Failure to do so may cause fire, equipment failures or malfunctions.
- Make sure to observe the following precautions in order to prevent malfunctions under the influence of noise:
 - Do not bundle the power line or twisted shielded cable together with or lay it close to the main circuit, high-voltage line, or load line. Otherwise, noise disturbance and/or surge induction are likely to take place. As a guideline, lay the control line at least 100mm (3.94") or more away from the main circuit, high-voltage line, or load line.
 - Ground the shield of the analog input/output cable at one point on the signal receiving side. However, do not use common grounding with heavy electrical systems.
- Make sure to properly wire to the European terminal board in accordance with the following precautions. Failure to do so may cause electric shock, equipment failures, a short-circuit, wire breakage, malfunctions, or damage to the product.
 - The disposal size of the cable end should follow the dimensions described in the manual.
 - Tightening torque should follow the specifications in the manual.
 - Twist the end of strand wire and make sure there are no loose wires.
 - Do not solder-plate the electric wire ends.
 - Do not connect more than the specified number of wires or electric wires of unspecified size.
 - Affix the electric wires so that neither the terminal block nor the connected parts are directly stressed.

3.1 Terminal Layout

The terminals of the PT-ADP are arranged as follows:

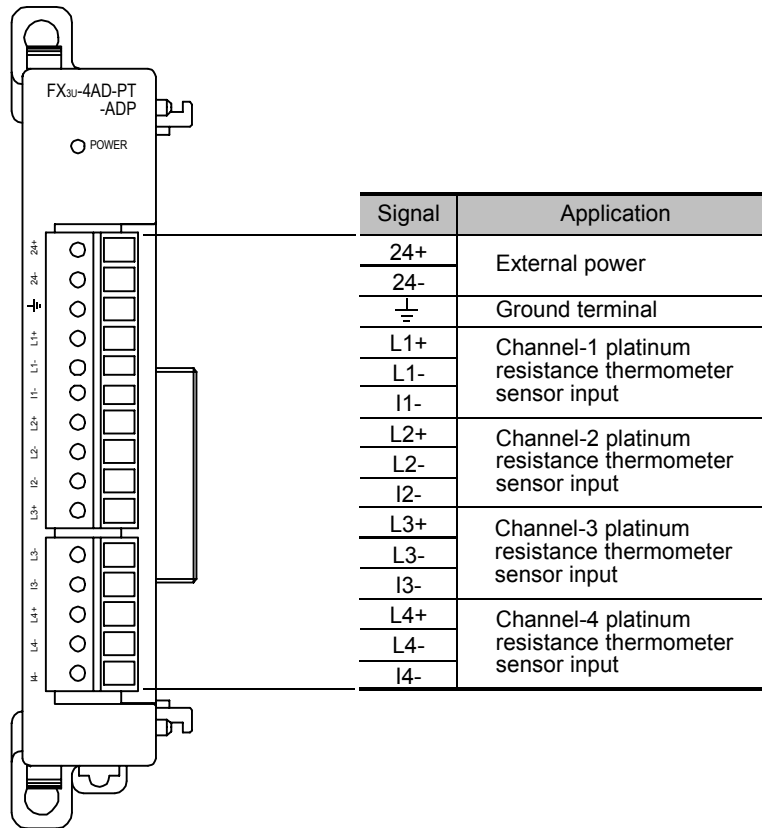

A Common Items

B FX3U-4AD
FX3UC-4AD

C FX3U-4AD-ADP

D FX3G-2AD-BD

E FX3U-4DA

F FX3U-4DA-ADP

G FX3G-1DA-BD

H FX3U-3A-ADP

I FX3U-4AD-PT-ADP

J FX3U-4AD-PTW-ADP

3.2 Applicable Cable and Terminal Tightening Torque

Use the following cables to connect with the counterpart equipment. Terminate the cable end as shown below. To connect the platinum resistance thermometer sensor, use the cable supplied with the Pt100 platinum resistance thermometer or a twisted pair shielded cable.

1. Cables

Applicable cable and tightening torque

	Wire size (stranded/single-wire)	Tightening torque	Termination
Single-wire	0.3mm ² to 0.5mm ² (AWG22 to 20)	0.22 N•m to 0.25 N•m	<ul style="list-style-type: none"> To connect a stranded cable, peel the cover off the cable and then twist the core before connection. To connect a single-wire cable, just strip the cover off the cable before connection.
2-wire	0.3mm ² (AWG22)		
Rod terminal with insulation sleeve	0.3mm ² to 0.5mm ² (AWG22 to 20) (Refer to the rod terminal external view shown in the following figure.)		<ul style="list-style-type: none"> Rod terminal with insulation sleeve (recommended terminal) AI 0.5-8WH : Manufactured by Phoenix Contact Caulking tool CRIMPFOX 6*1 : Manufactured by Phoenix Contact (or CRIMPFOX 6T-F*2 : Manufactured by Phoenix Contact)

*1. Old model name : CRIMPFOX ZA 3

*2. Old model name : CRIMPFOX UD 6

2. Termination of cable ends

To terminate the cable, treat the stranded/single wire directly or use a rod terminal with insulation sleeve.

- To directly terminate the end of a stranded/single-wire cable:
 - Twist the end of the stranded cable so that the "barbed wires" cannot protrude.
 - Do not solder-plate the end of the cable.

Termination of cable end

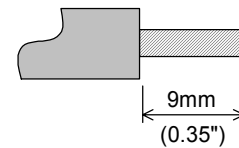

- To terminate cable end using a rod terminal with insulation sleeve:
 If the cable sheath is too thick, it may be difficult to insert the cable into the insulation sleeve. For this reason, select an appropriate cable while referring to the external view.
 <Reference>

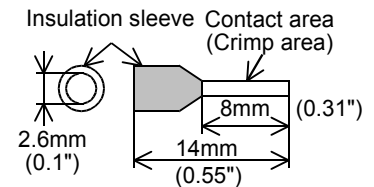

Manufacturer	Model	Caulking tool
Phoenix Contact	AI 0.5-8WH	CRIMPFOX 6*3 (or CRIMPFOX 6T-F*4)

*3. Old model name : CRIMPFOX ZA 3

*4. Old model name : CRIMPFOX UD 6

3. Tool

- To tighten terminals, use a small-sized screwdriver whose head is straight and is not widened as shown in the figure to the right.

Note:

If the diameter of screwdriver grip is too small, tightening torque will not be able to be achieved. To achieve the appropriate tightening torque shown in the table above, use the following screwdriver or an appropriate replacement (grip diameter: approximately 25mm (0.98")).
 <Reference>

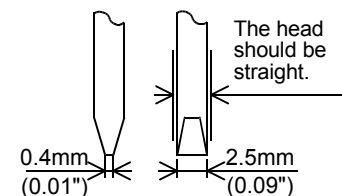

Manufacturer	Type
Phoenix Contact	SZS 0.4 × 2.5

3.3 Power Supply Line

Connect the 24V DC power supply line of the PT-ADP to the 24+ and 24- terminals of the terminal block.

3.3.1 To connect to the FX3G, FX3U Series PLC

1. To use an external power

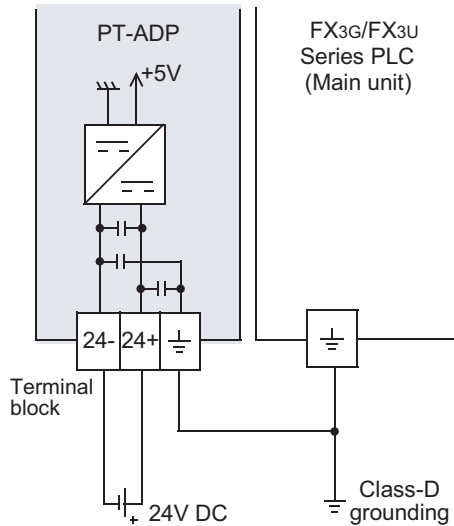

2. To use the 24V DC power of the PLC

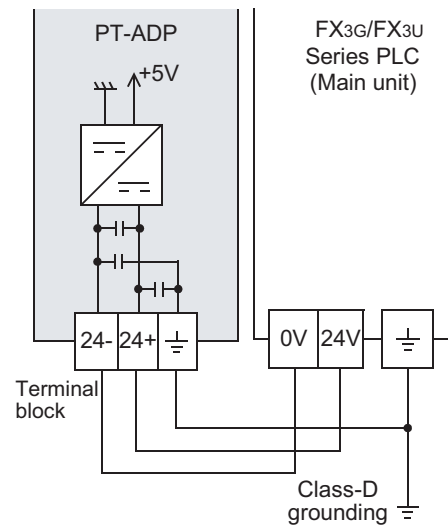

Caution regarding connection of the power supply line:

- Ground the " \perp " terminal to a class-D grounding power supply line (100Ω or less) together with the ground terminal of the PLC main unit.
- When using an external power supply, turn it ON at the same time with the main unit or earlier than the main unit. When turning OFF the power, confirm the safety of the system, and then turn OFF the power of the PLC (including special adapter) at the same time.

3.3.2 To connect to the FX3UC Series PLC

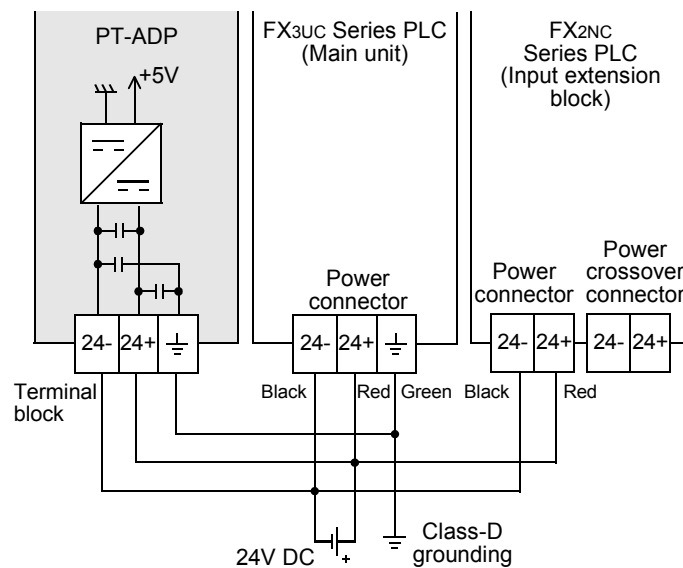

Caution regarding connection of the power supply line:

- For the 24V DC power supply line, be sure to use the same power as the FX3UC Series PLC.
- Ground the " \perp " terminal to a class-D grounding power supply line (100Ω or less) together with the grounding terminal of the PLC main unit.

3.4 Selection of the Platinum Resistance Thermometer Sensor

Select the Pt100 3-wire platinum resistance thermometer sensor.
 This thermometer will not be affected by voltage drop in the wiring area, and will ensure accurate measurement.

3.5 Wiring of the Platinum Resistance Thermometer Sensor

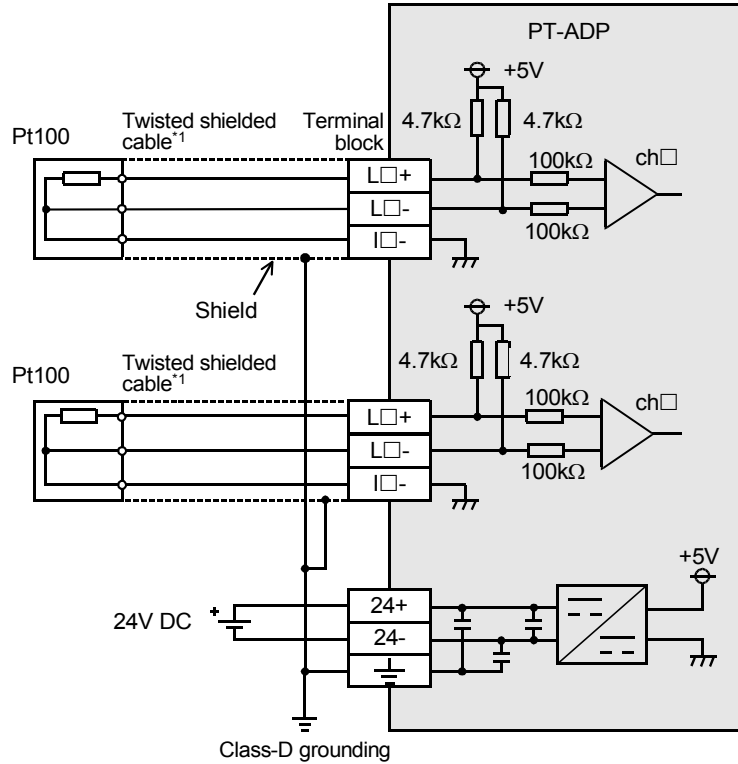

L□+, L□-, I□-, ch□: □ represents the channel number.

*1. Separate the cable of the platinum resistance thermometer sensor from the other power cables or areas easily affected by inductive noise (of the commercial power, etc.).

3.6 Grounding

Grounding should be performed as stated below.

- The grounding resistance should be 100Ω or less.
- Independent grounding should be performed for best results. When independent grounding is not performed, perform "shared grounding" as shown in the following figure.

→ For details, refer to the User's Manual - Hardware Edition of the PLC Series.

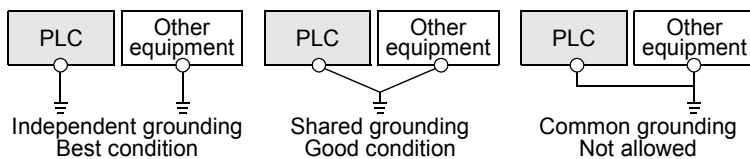

- The grounding wire size should be AWG22 to 20 (0.3 to 0.5 mm²).
- The grounding point should be close to the PLC, and all grounding wires should be as short as possible.

4. Programming

This chapter describes how to create programs that can read analog data using the PT-ADP.

4.1 Loading of A/D Conversion Data

- 1) The input analog data will be converted into digital data and then stored in the special devices of the FX3U/FX3UC/FX3G Series PLC.
- 2) If data is stored in the special devices, the averaging time can be set, and the input mode can be specified.
- 3) Special auxiliary relays (10 points) and special data registers (10 points) are assigned automatically starting from the adapter nearest to the main unit.

→ For a detailed description of special device assignment, refer to Section 4.2.

- FX3U, FX3UC Series PLC

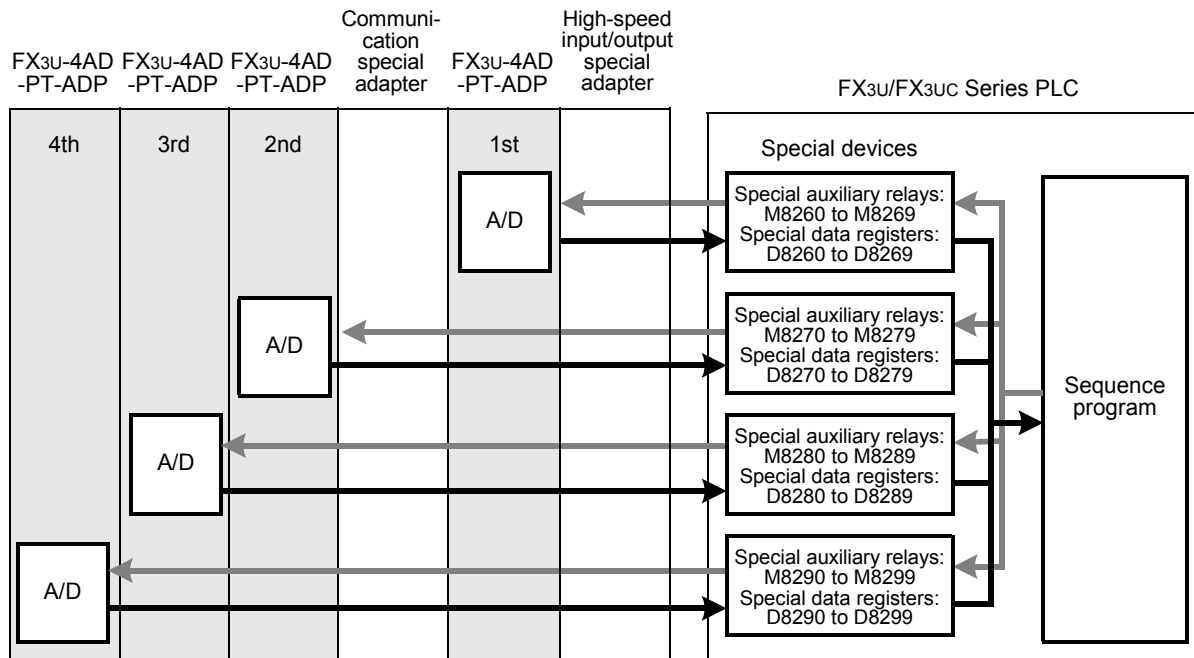

The analog special adapter nearest to the main unit is counted as the 1st analog special adapter, and the next adapter as the 2nd analog special adapter, and so on. However, in this case, do not include the high-speed input/output special adapter, communication special adapter, and the CF card special adapter.

• FX3G Series PLC

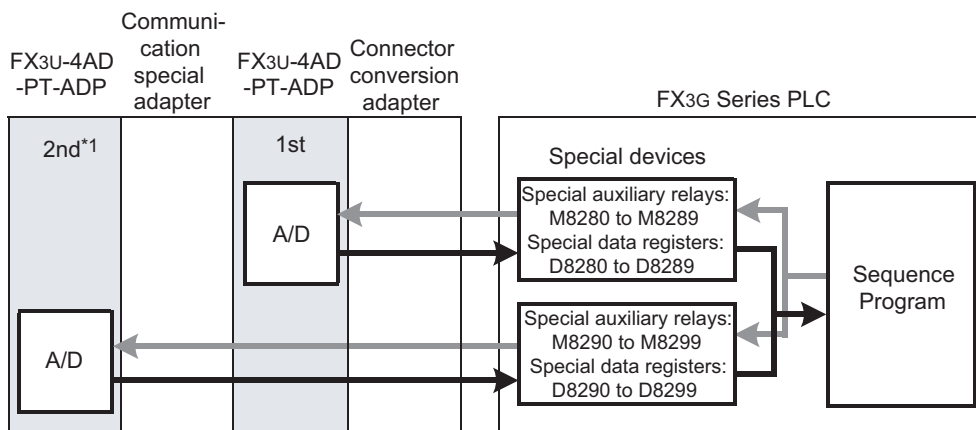

The analog special adapter nearest to the main unit is counted as the 1st analog special adapter, and the next adapter as the 2nd analog special adapter. However, in this case, do not include the connector conversion adapter and the communication special adapter.

*1. The second special adapter is not available in the FX3G Series PLC(14-point and 24-point type).

4.2 List of Special Devices

If the PT-ADP is connected, special devices will be assigned automatically as shown in the following table:

- FX3U, FX3UC Series PLC

R: Read / W: Write

Special device	Device number				Description	Attribute	Reference
	1st	2nd	3rd	4th			
Special auxiliary relay	M8260	M8270	M8280	M8290	Selects the temperature unit.	R/W	Section 4.3
	M8261 to M8269	M8271 to M8279	M8281 to M8289	M8291 to M8299	Unused (Do not use.)	-	-
Special data register	D8260	D8270	D8280	D8290	Channel-1 temperature measurement data	R	Section 4.4
	D8261	D8271	D8281	D8291	Channel-2 temperature measurement data	R	
	D8262	D8272	D8282	D8292	Channel-3 temperature measurement data	R	
	D8263	D8273	D8283	D8293	Channel-4 temperature measurement data	R	
	D8264	D8274	D8284	D8294	Averaging time for channel 1 (Setting range: 1 to 4095)	R/W	Section 4.5
	D8265	D8275	D8285	D8295	Averaging time for channel 2 (Setting range: 1 to 4095)	R/W	
	D8266	D8276	D8286	D8296	Averaging time for channel 3 (Setting range: 1 to 4095)	R/W	
	D8267	D8277	D8287	D8297	Averaging time for channel 4 (Setting range: 1 to 4095)	R/W	
	D8268	D8278	D8288	D8298	Error status	R/W	Section 4.6
	D8269	D8279	D8289	D8299	Model code = 20	R	Section 4.7

A
Common Items

B
FX3U-4AD
FX3UC-4AD

C
FX3U-4AD-ADP

D
FX3G-2AD-BD

E
FX3U-4DA

F
FX3U-4DA-ADP

G
FX3G-1DA-BD

H
FX3U-3A-ADP

I
FX3U-4AD-PT-ADP

J
FX3U-4AD-PTW-ADP

- FX3G Series PLC

R: Read / W: Write

Special device	Device number		Description	Attribute	Reference
	1st	2nd			
Special auxiliary relay	M8280	M8290	Selects the temperature unit.	R/W	Section 4.3
	M8281 to M8289	M8291 to M8299	Unused (Do not use.)	-	-
Special data register	D8280	D8290	Channel-1 temperature measurement data	R	Section 4.4
	D8281	D8291	Channel-2 temperature measurement data	R	
	D8282	D8292	Channel-3 temperature measurement data	R	
	D8283	D8293	Channel-4 temperature measurement data	R	
	D8284	D8294	Averaging time for channel 1 (Setting range: 1 to 4095)	R/W	Section 4.5
	D8285	D8295	Averaging time for channel 2 (Setting range: 1 to 4095)	R/W	
	D8286	D8296	Averaging time for channel 3 (Setting range: 1 to 4095)	R/W	
	D8287	D8297	Averaging time for channel 4 (Setting range: 1 to 4095)	R/W	
	D8288	D8298	Error status	R/W	Section 4.6
	D8289	D8299	Model code = 20	R	Section 4.7

4.3 Selection of Temperature Unit

To switch the temperature unit of the PT-ADP turn the special auxiliary relay ON for Fahrenheit (°F) or OFF for Centigrade (°C).

To switch the temperature unit, use the following special auxiliary relays:

- FX3U, FX3UC Series PLC

Special auxiliary relay				Description
1st	2nd	3rd	4th	
M8260	M8270	M8280	M8290	Selection of temperature unit: OFF: Centigrade (°C) ON: Fahrenheit (°F)

- FX3G Series PLC

Special auxiliary relay		Description
1st	2nd	
M8280	M8290	Selection of temperature unit: OFF: Centigrade (°C) ON: Fahrenheit (°F)

1. Program Example (For FX3U, FX3UC Series PLC)

1) To switch the temperature unit to centigrade (°C) for the 1st adapter:

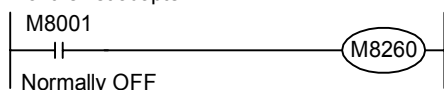

2) To switch the temperature unit to Fahrenheit (°F) for the 2nd adapter:

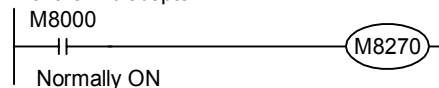

4.4 Temperature Measurement

The temperature data input in the PT-ADP will be stored in the special data registers. The special data registers that store the temperature data are shown in the following table:

- FX3U, FX3UC Series PLC

Special data register				Description
1st	2nd	3rd	4th	
D8260	D8270	D8280	D8290	Stores the channel-1 temperature measurement data.
D8261	D8271	D8281	D8291	Stores the channel-2 temperature measurement data.
D8262	D8272	D8282	D8292	Stores the channel-3 temperature measurement data.
D8263	D8273	D8283	D8293	Stores the channel-4 temperature measurement data.

- FX3G Series PLC

Special data register		Description
1st	2nd	
D8280	D8290	Stores the channel-1 temperature measurement data.
D8281	D8291	Stores the channel-2 temperature measurement data.
D8282	D8292	Stores the channel-3 temperature measurement data.
D8283	D8293	Stores the channel-4 temperature measurement data.

The immediate data or the average data (data averaged in accordance with the specified averaging time) will be stored in the above data registers as the temperature measurement data.

→ For a detailed description of the averaging time, refer to Section 4.6.

1. Caution regarding temperature measurement

The special data registers for temperature measurement data are for reading only. Do not change (rewrite) the current data using the sequence program, indicator, or device monitor of the programming tool.

2. Program Example (For FX3U, FX3UC Series PLC)

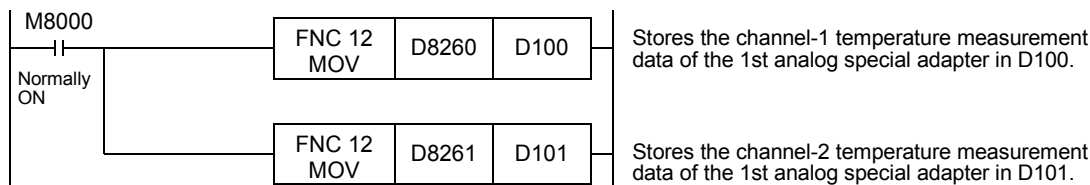

Even if the temperature measurement data is not stored in the D100 or the D101, the D8260 or the D8261 can be directly used in the arithmetic operation instruction or a PID instruction.

4.5 Averaging Time

Setting range: 1 to 4095
Initial value: K1
Numeric data type: Decimal (K)

If the averaging time is set for the PT-ADP, the averaged temperature measurement data will be stored in the D8260 to D8263, D8270 to D8273, D8280 to D8283, and D8290 to D8293. The averaging time can be set for each channel.

Set the averaging time in the following special data registers:

- FX3U, FX3UC Series PLC

Special data register				Description
1st	2nd	3rd	4th	
D8264	D8274	D8284	D8294	Averaging time for channel-1 data
D8265	D8275	D8285	D8295	Averaging time for channel-2 data
D8266	D8276	D8286	D8296	Averaging time for channel-3 data
D8267	D8277	D8287	D8297	Averaging time for channel-4 data

- FX3G Series PLC

Special data register		Description
1st	2nd	
D8284	D8294	Averaging time for channel-1 data
D8285	D8295	Averaging time for channel-2 data
D8286	D8296	Averaging time for channel-3 data
D8287	D8297	Averaging time for channel-4 data

1. Cautions regarding averaging time setting

- If the averaging time is set to "1", the immediate data will be stored in the temperature measurement special data register.
- If the averaging time is set to "2" or more, the average value will be calculated in accordance with the set averaging time, and the average value obtained will be stored in the temperature measurement special data register.
- After turning the PLC power on, the average data will be stored in the temperature measurement special data registers (D8260 to D8263, D8270 to D8273, D8280 to D8283, and D8290 to D8293) until the number of data items is increased to the set averaging time.
- Set the averaging time in the range from 1 to 4095. If the set value is outside the setting range, the error signal will be output.
- If the averaging time is set to "0" or smaller, the PLC will perform as if the averaging time is set to "1". If the averaging time is set to "4096" or larger, the PLC will perform as if the averaging time is set to "4096".
 → For a detailed description of error status, refer to Section 5.5

2. Program Example (For FX3U, FX3UC Series PLC)

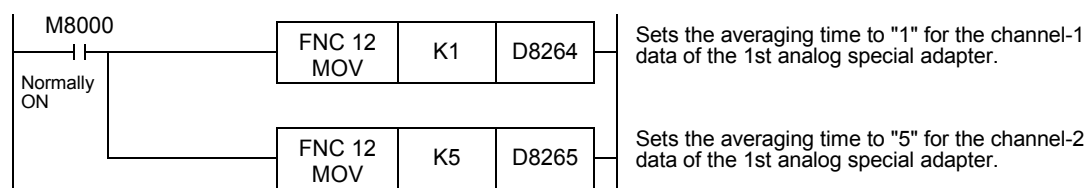

Sets the averaging time to "1" for the channel-1 data of the 1st analog special adapter.

Sets the averaging time to "5" for the channel-2 data of the 1st analog special adapter.

4.6 Error Status

If an error is detected in the PT-ADP, the error status data will be stored in the corresponding special data register.

The following table shows the special data registers that store the error status data:

- FX3U, FX3UC Series PLC

Special data register				Description
1st	2nd	3rd	4th	
D8268	D8278	D8288	D8298	Stores the error status data.

- FX3G Series PLC

Special data register		Description
1st	2nd	
D8288	D8298	Stores the error status data.

Check the ON/OFF status of each bit of the error status data register to determine the error. Errors are assigned to the bits as shown in the following table. Create a program to detect errors.

Bit	Description	Bit	Description
b0	The temperature measurement data of channel 1 is outside the specified range, or disconnection is detected.	b5	Averaging time setting error
b1	The temperature measurement data of channel 2 is outside the specified range, or disconnection is detected.	b6	PT-ADP hardware error
b2	The temperature measurement data of channel 3 is outside the specified range, or disconnection is detected.	b7	PT-ADP communication data error
b3	The temperature measurement data of channel 4 is outside the specified range, or disconnection is detected.	b8 to b15	Unused
b4	EEPROM error	-	-

1. Caution regarding use of error status data

If a PT-ADP hardware error (b6) or PT-ADP communication data error (b7) is detected, it is necessary to clear the error status with a program at the next power-on of the PLC.

For this reason, be sure to create the following program:

- For FX3G, FX3U, FX3UC Series PLC

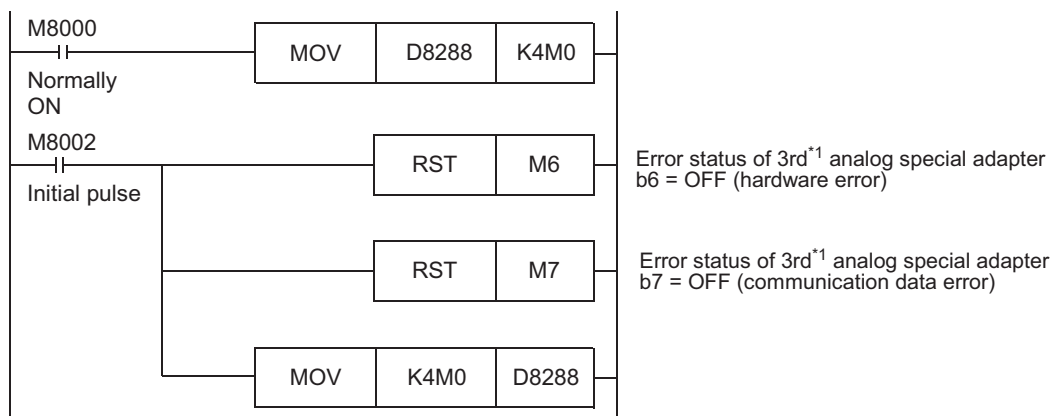

*1. "1st" for the FX3G PLC.

- For FX3U, FX3UC Series PLC

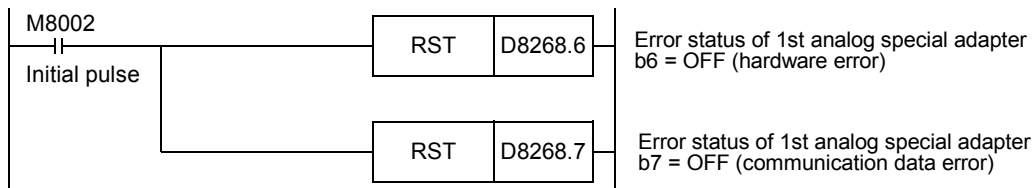

2. Program Example 1 (For FX3G, FX3U, FX3UC Series PLC)

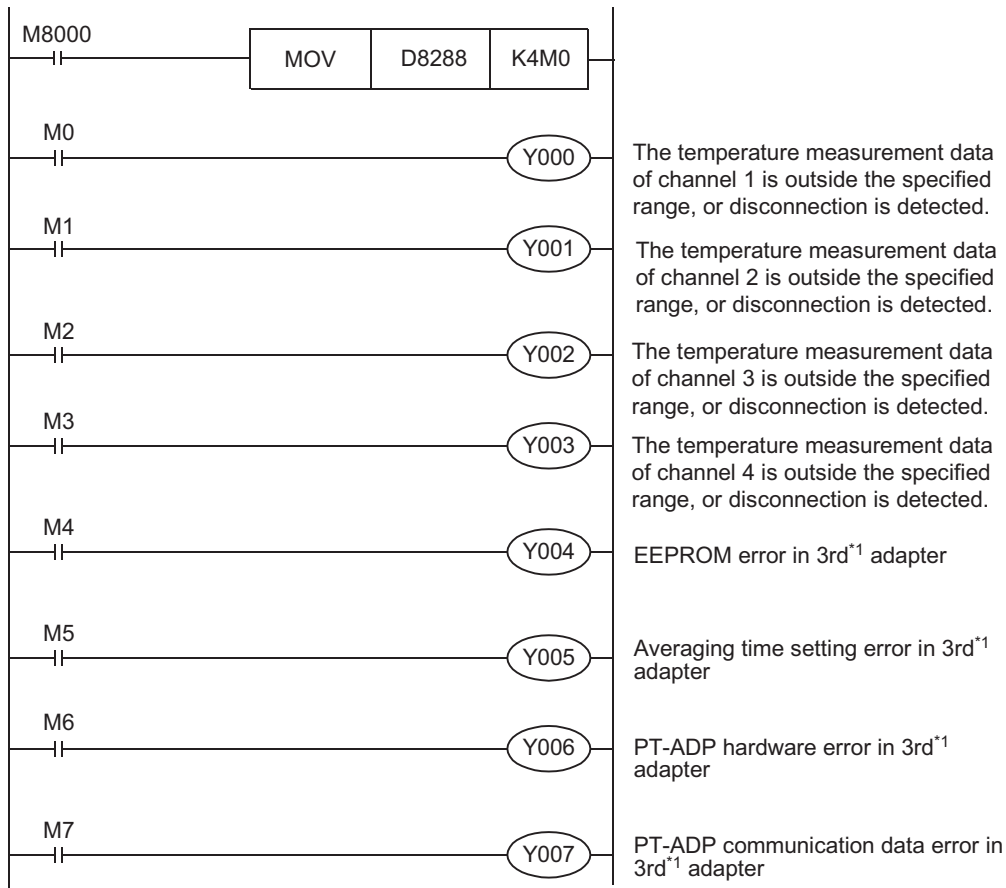

*1. "1st" for the FX3G PLC.

3. Program Example 2 (For FX3U, FX3UC Series PLC)

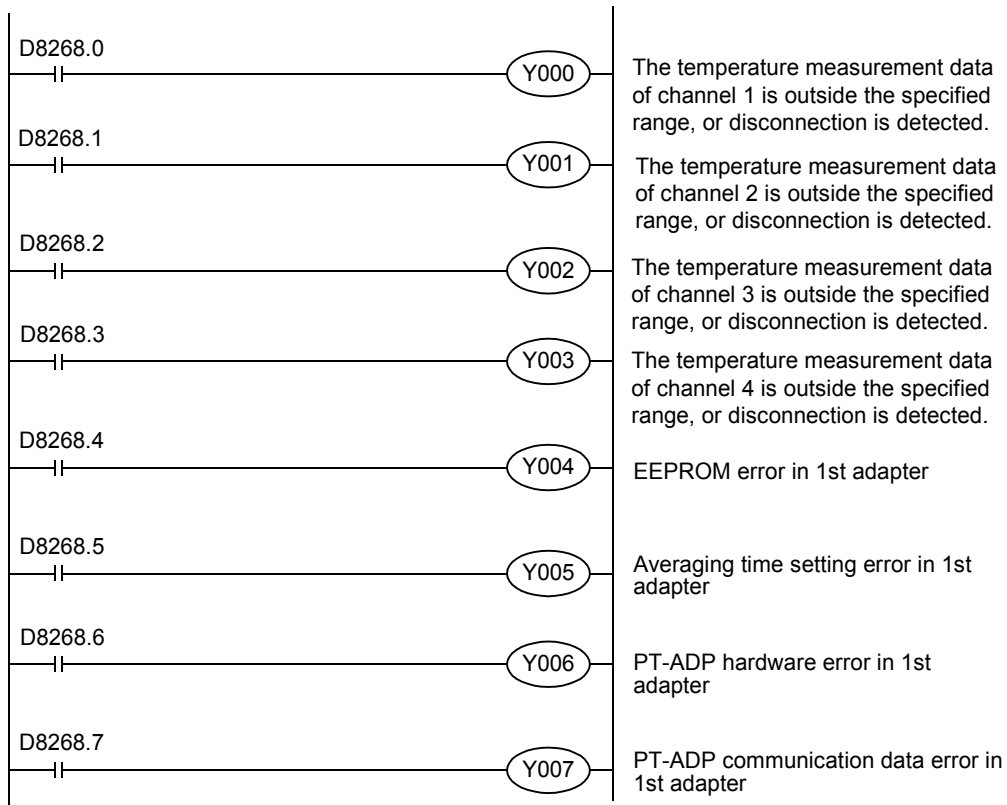

A
Common Items

B
FX3U-4AD
FX3UC-4AD

C
FX3U-4AD-ADP

D
FX3G-2AD-BD

E
FX3U-4DA

F
FX3U-4DA-ADP

G
FX3G-1DA-BD

H
FX3U-3A-ADP

I
FX3U-4AD-PT-ADP

J
FX3U-4AD-PTW-ADP

4.7 Model Code

Initial value: K20

Numeric data type: Decimal (K)

When the PT-ADP is connected, model code "20" will be stored in the corresponding special data register. The following table shows the special data registers that store the model code:

- FX3U, FX3UC Series PLC

Special data register				Description
1st	2nd	3rd	4th	
D8269	D8279	D8289	D8299	Model code

- FX3G Series PLC

Special data register		Description
1st	2nd	
D8289	D8299	Model code

Use the special data registers above to check whether PT-ADP is connected or not.

1. Program Example (For FX3U, FX3UC Series PLC)

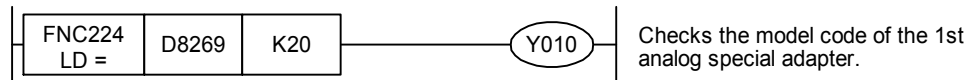

4.8 Basic Program Example

Create the following basic program example to read out the temperature measurement data.

- For FX3G, FX3U, FX3UC Series PLC

The following program will store the temperature measurement data (°C) from channels 1 and 2 of the 3rd¹ adapter to D100 and D101, respectively. The averaging time is set to "1" (immediate data) for channel 1, and "5" for channel 2.

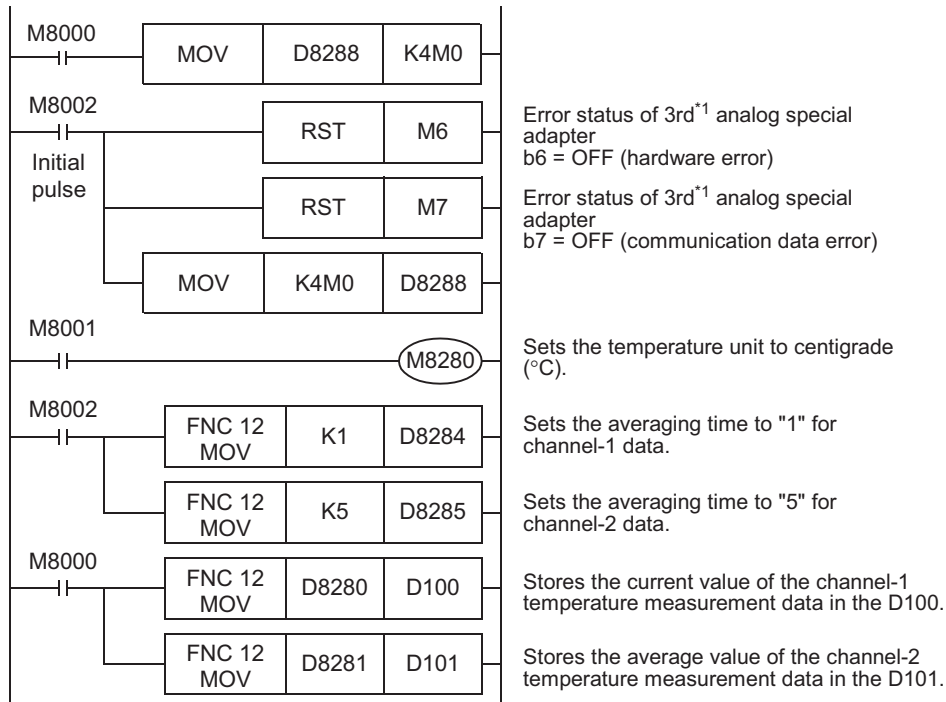

Even if the temperature measurement data is not stored in D100 or D101, data register D8280 or D8281 can be directly used in the arithmetic operation instruction or a PID instruction.

*1. "1st" for the FX3G PLC.

- For FX3U, FX3UC Series PLC

The following program will store the temperature measurement data (°C) from channels 1 and 2 of the 1st adapter to D100 and D101, respectively. The averaging time is set to "1" (immediate data) for channel 1, and "5" for channel 2.

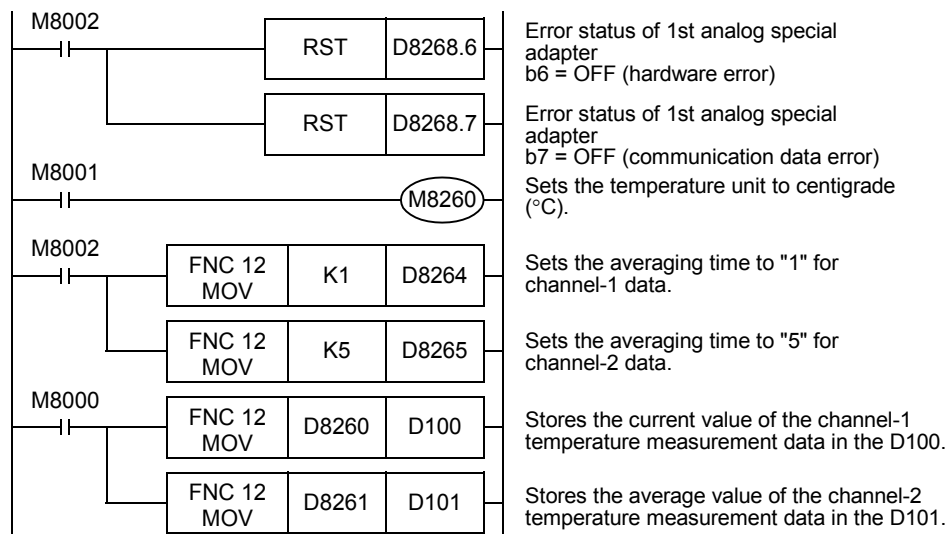

Even if the temperature measurement data is not stored in D100 or D101, data register D8260 or D8261 can be directly used in the arithmetic operation instruction or a PID instruction.

5. Troubleshooting

This chapter describes the troubleshooting methods and error status.

If the temperature measurement data is not input, or if the proper digital value is not input, check the following items:

- Version number of the PLC
- Wiring
- Special devices
- Programs
- Error status

5.1 PLC Version Number Check

- Any versions (from Ver.2.20 (initial version) to the latest version) of the FX3U Series are compatible.
- Check the version number of the FX3UC Series. The version number should be 1.30 or later.
- Any versions (from Ver.1.00 (initial version) to the latest version) of the FX3G Series are compatible.
→ **For a detailed description of the version number check method, refer to Section 1.3.**

5.2 Wiring Check

Check the following items for wiring:

1. Power

The PT-ADP needs driving power. Verify that the power supply line is properly connected. Also check that the POWER indicator lamp of the PT-ADP is on.

2. Platinum resistance thermometer sensor cable

Separate the cable of the platinum resistance thermometer from other power cables or inductive cables.

→ **For a detailed description of wiring, refer to Chapter 3.**

5.3 Special Device Check

Check whether the special devices for the PT-ADP are correctly used:

1. Temperature measurement

Verify that the special device for the selected channel is correctly selected. This special device should be selected depending on the connecting position and the channel.

2. Averaging time

Check that the set averaging time is within the specified range. The averaging time should be set in the range from 1 to 4095. If the set averaging time is outside the specified range, an error occurs.

3. Error status

Check that no error is detected in the PT-ADP.

If an error is detected, check the details of the error, and then check the wiring and programs.

→ **For a detailed description of special devices, refer to Chapter 4.**

5.4 Program Check

Check the following items for the program:

1. Cancellation of error status at power-on

When the power is turned off and then on again, the error status should be cleared (b6 and b7 should turn off) using the program.

2. Check of storage devices

Verify that different values are not being stored in the same device by the other parts of the programs.

5.5 Error Status Check

If an error occurs in the PT-ADP, the corresponding bit will turn on.

The bit which is turned ON due to the error status is held ON until overwritten to OFF by the program or the power is cycled. If b6 or b7 is turned ON, then it is necessary to clear the error status using the program the next time the power of the PLC is cycled.

Bit	Description	Bit	Description
b0	The temperature measurement data of channel 1 is outside the specified range, or disconnection is detected.	b5	Averaging time setting error
b1	The temperature measurement data of channel 2 is outside the specified range, or disconnection is detected.	b6	PT-ADP hardware error
b2	The temperature measurement data of channel 3 is outside the specified range, or disconnection is detected.	b7	PT-ADP communication data error
b3	The temperature measurement data of channel 4 is outside the specified range, or disconnection is detected.	b8 to 15	Unused
b4	EEPROM error	-	-

To solve a problem, refer to the troubleshooting method described below:

1. Temperature measurement out of specified range or disconnection of line (b0 to b3)

1) Description of error

The input temperature measurement value is outside the specified range.
 The temperature measurement value is not in the range between -55°C to 255°C.
 Or the line between PT-ADP and the platinum resistance thermometer sensor is disconnected.

2) Remedy

Check that the input temperature measurement value is within the specified range. Also check the wiring condition.

2. EEPROM error (b4)

1) Description of error

The adjustment data set in the EEPROM before delivery from our factory cannot be read out properly or is destroyed.

2) Remedy

Please contact the nearest Mitsubishi Electric distributor office.

3. Averaging time setting error (b5)

1) Description of error

The averaging time set for one of the channels (channels 1 to 4) is outside the specified range: 1 to 4095.

2) Remedy

Check that the averaging time is correctly set for each channel.

4. PT-ADP hardware error (b6)

- 1) Description of error
The PT-ADP does not operate properly.
- 2) Remedy
Check that the 24V DC power is properly supplied to the PT-ADP. Also check that the PT-ADP is correctly connected to the PLC.
If the problem cannot be solved even after the above check, please contact the nearest Mitsubishi Electric distributor office.

5. PT-ADP communication data error (b7)

- 1) Description of error
A communication error is detected between the PT-ADP and the PLC.
- 2) Remedy
Check that the PT-ADP is correctly connected to the PLC.
If the problem cannot be solved even after the above check, please contact the nearest Mitsubishi Electric distributor office.

FX3G/FX3U/FX3UC Series Programmable Controllers

User's Manual [Analog Control Edition] FX3U-4AD-PTW-ADP (4-channel Platinum Resistance Thermometer Data Input)

Foreword

This manual describes the specifications, wiring, and operation methods for the FX3U-4AD-PTW-ADP special adapter (4-channel platinum resistance thermometer input) and should be read and understood before attempting to install or use the unit.

Store this manual in a safe place so that you can take it out and read it whenever necessary. Always forward it to the end user.

This manual confers no industrial property rights or any rights of any other kind, nor does it confer any patent licenses. Mitsubishi Electric Corporation cannot be held responsible for any problems involving industrial property rights which may occur as a result of using the contents noted in this manual.

© 2005 MITSUBISHI ELECTRIC CORPORATION

A
Common Items

B
FX3U-4AD
FX3UC-4AD

C
FX3U-4AD-ADP

D
FX3G-2AD-BD

E
FX3U-4DA

F
FX3U-4DA-ADP

G
FX3G-1DA-BD

H
FX3U-3A-ADP

I
FX3U-4AD-PT
-ADP

J
FX3U-4AD-PTW
-ADP

1. Outline

This chapter describes the outline of FX3U-4AD-PTW-ADP (referred to as PTW-ADP).

1.1 Outline of Functions

The FX3U-4AD-PTW-ADP is an analog special adapter. Connect the FX3U-4AD-PTW-ADP to the FX3U/FX3UC/FX3G Series PLC to read the temperature data from the 4-channel platinum resistance thermometers.

- 1) Up to 4 PTW-ADP units can be connected to the FX3U/FX3UC Series PLC.
 Up to 2*¹ PTW-ADP units can be connected to the FX3G Series PLC.
 (including other analog special adapters)
- 2) After connection of the platinum resistance thermometer (Pt100), measurement of temperature will be possible.
- 3) The temperature measurement data will be automatically written to the special data registers of the FX3U/FX3UC/FX3G Series PLC.

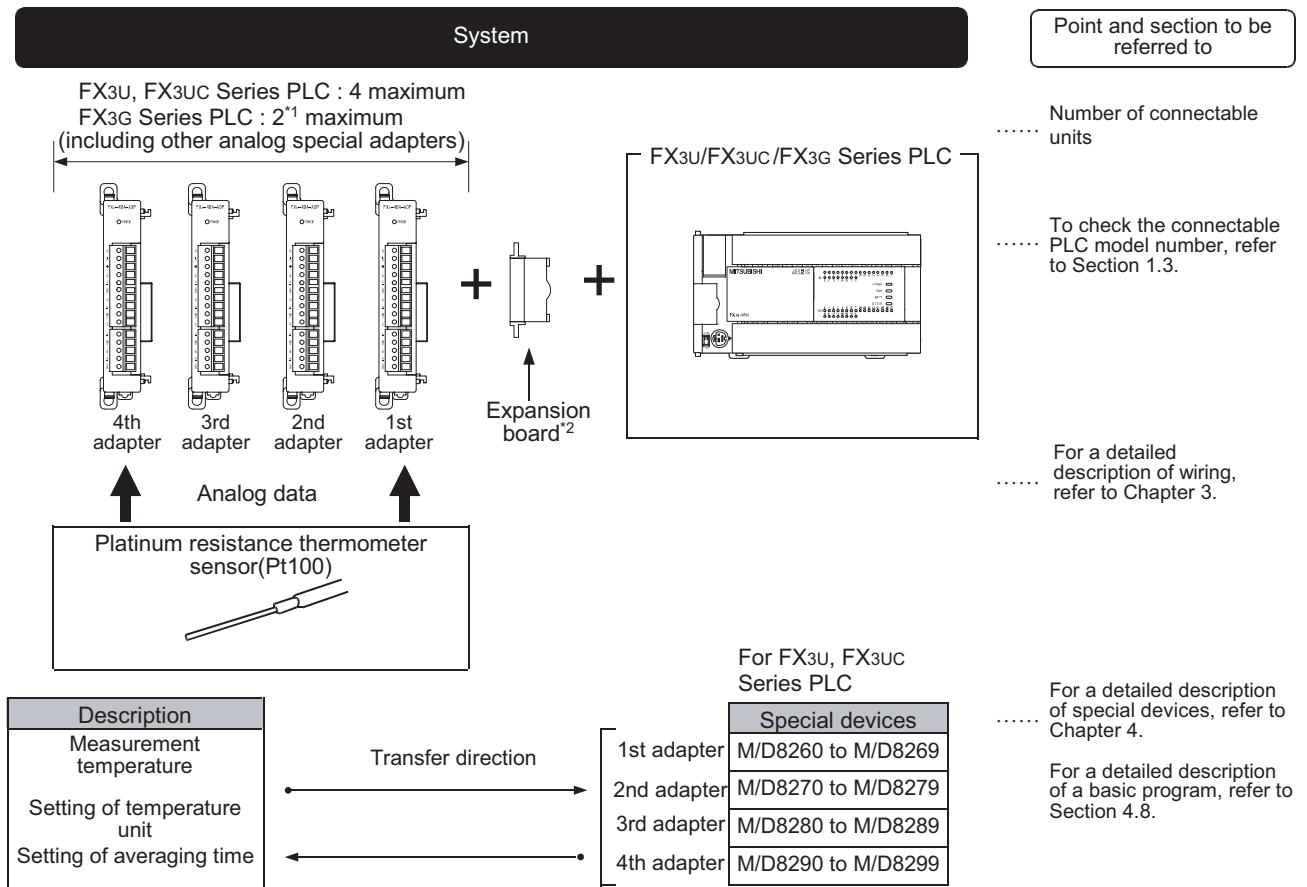

Refer to the system configuration shown in the User's Manual - Hardware Edition to check the number of connectable units and to configure the entire system.

*1. Only 1 analog special adapter can be connected to the 14-point and 24-point type main unit.

*2. The expansion board is not required when connecting with the FX3UC (D, DSS) PLC.

For the FX3G Series PLC a connector conversion adapter is used.

A Common Items

B FX3U-4AD
FX3UC-4AD

C FX3U-4AD-ADP

D FX3G-2AD-BD

E FX3U-4DA

F FX3U-4DA-ADP

G FX3G-1DA-BD

H FX3U-3A-ADP

I FX3U-4AD-PTW-ADP

J FX3U-4AD-PTW-ADP

1.2 Setup Procedure Before Starting Operation

Before starting analog input using the PTW-ADP, follow the procedure below to set up the system:

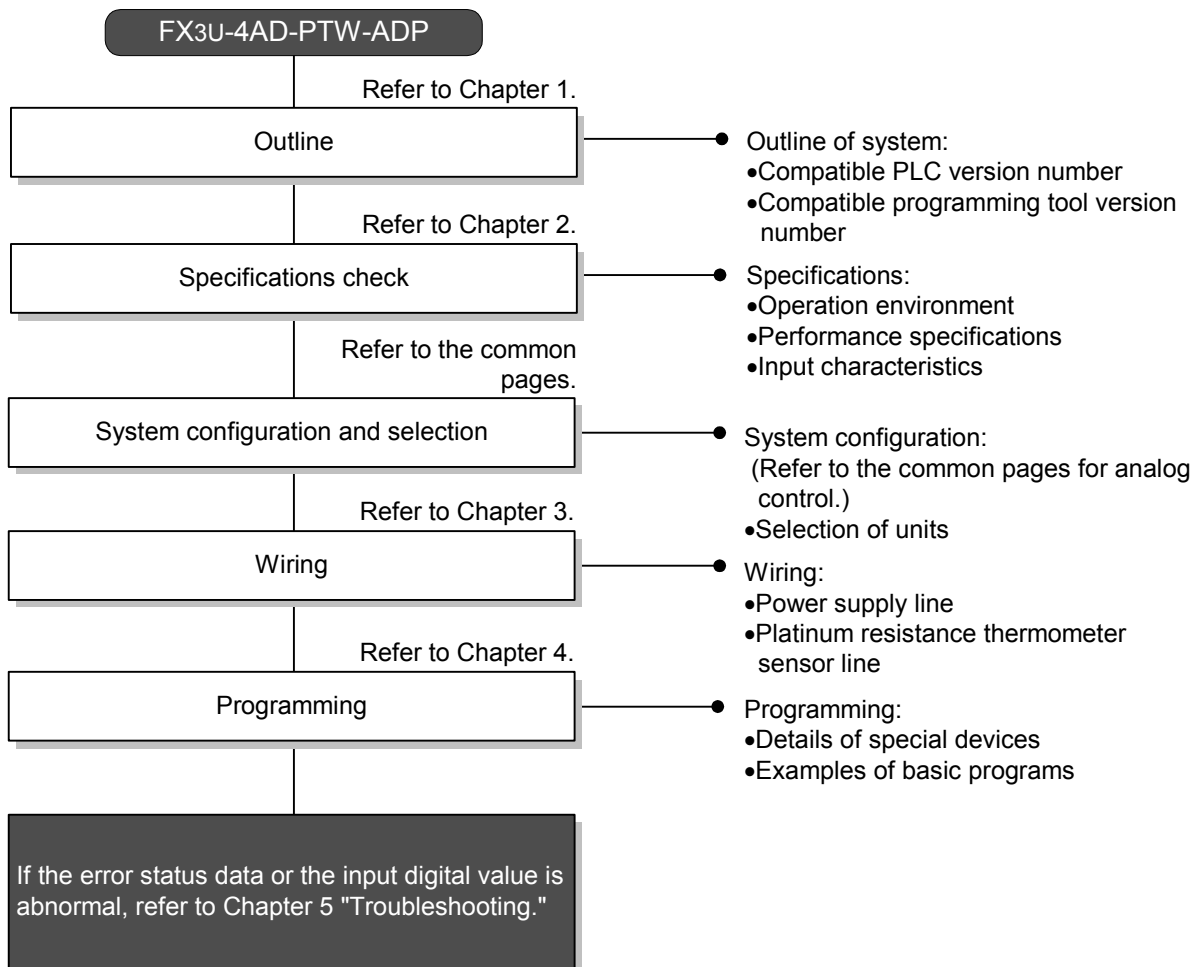

1.3 Connectable PLC and Its Version Number

PTW-ADP is compatible with the following PLC.

Compatible PLC	Version number	Date of production
FX3U Series PLC	Ver. 2.20 or later	After May 2005 (initial production)
FX3UC Series PLC	Ver. 1.30 or later	After August 2004
FX3G Series PLC	Ver. 1.00 or later	After June 2008 (initial production)

1. Version check

Special data register D8001 contains information for determining the PLC version.

→ For a detailed description of the version check, refer to A. Common Items Subsection 5.1.2.

2. How to check the manufacturer's serial number

The year and month of production of the product can be checked on the nameplate, and on the front of the product.

→ For a detailed description of how to check the manufacturer's serial number, refer to A. Common Items Subsection 5.1.1.

1.4 Compatible Programming Tool Version Number

Use the programming tool with the following version number to create programs for PTW-ADP of the FX3U/FX3UC/FX3G Series PLC:

1. GX Works2

Software	Version number	Remarks
GX Works2 SW□DNC-GXW2-J	Ver. 1.07H or later	-
GX Works2 SW□DNC-GXW2-E	Ver. 1.08J or later	-

2. GX Developer

- FX3U/FX3UC Series PLC

Software	Version number	Remarks
GX Developer SW□D5C-GPPW-J	Ver. 8.13P or later	When selecting the model, select FX3U(C)*1.
GX Developer SW□D5C-GPPW-E	Ver. 8.18U or later	

- FX3G Series PLC

Software	Version number	Remarks
GX Developer • SW□D5C-GPPW-J • SW□D5C-GPPW-E	Ver. 8.72A or later	-

If a programming tool with the wrong version number is used, programming will not be possible.

*1. For Ver. 8.13P to 8.24A of GX Developer, select FX3UC for the PLC type.

3. FX-30P

Model name	Version number	Remarks
FX-30P	Ver. 1.00 or later	-

2. Specifications

This chapter describes the general, power supply, and performance specifications for the PTW-ADP.

2.1 Generic Specifications

Item	Specifications				
Ambient temperature	0 to 55°C (32 to 131°F) when operating -25 to 75°C (-13 to 167°F) when stored				
Relative humidity	5 to 95%RH (no condensation) when operating				
Vibration resistance *1	DIN Rail Mounting	Frequency (Hz)	Acceleration (m/s ²)	Half amplitude (mm)	Tested 10 times in each direction (X-, Y-, and Z-axis directions) (Total: 80 min, each)
		10 - 57	-	0.035	
	Direct Mounting *2	57 - 150	4.9	-	
		10 to 57	-	0.075	
Direct Mounting *2	57 to 150	9.8	-		
	Shock resistance *1	147 m/s ² Acceleration, Action time: 11ms, 3 times by half-sine pulse in each direction X, Y, and Z			
Noise resistance	Using noise simulator of: Noise voltage: 1,000Vp-p / Noise width: 1μs / Rise: 1ns / Cycle: 30 to 100Hz				
Dielectric withstand voltage	500 V AC, for 1 min	Between all terminals and ground terminal			
Insulation resistance	5MΩ or more using 500V DC insulation resistance meter				
Grounding	Class D grounding (grounding resistance: 100 Ω or less) <Common grounding with a heavy electrical system is not allowed.>*3				
Working environment	Free from corrosive or flammable gas and excessive conductive dusts				
Working altitude	< 2000m*4				

*1. The criterion is shown in IEC61131-2.

*2. If PTW-ADP is connected to the FX3UC Series PLC, direct installation is not possible.

*3.

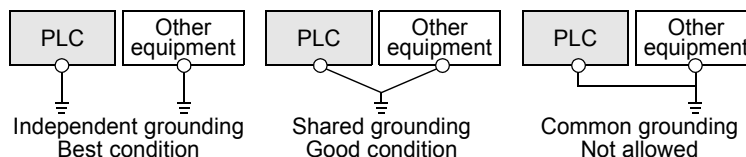

→ For a detailed description of the grounding, refer to Section 3.6.

*4. If the pressure is higher than the atmospheric pressure, do not use the PTW-ADP. The PTW-ADP may malfunction.

2.2 Power Supply Specifications

Items	Specification
A/D conversion circuit driving power	24V DC +20% -15%, 50mA (It is necessary to connect a 24V DC power supply to the terminal block.)
Interface driving power	5V DC, 15mA (Since the internal power is supplied from the FX Series main unit, it is not necessary to supply the power.)

2.3 Performance Specifications

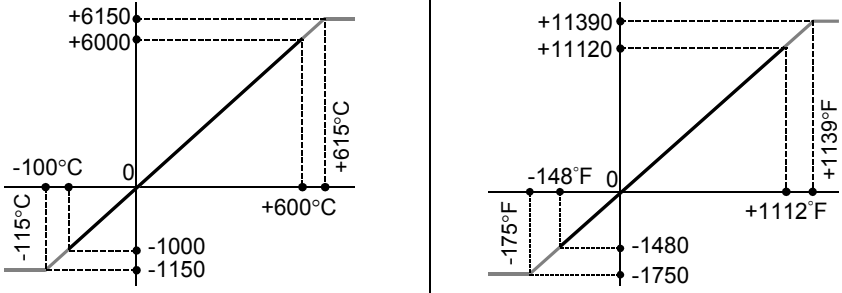
Items	Specifications	
	Centigrade (°C)	Fahrenheit (°F)
Input signal	3-wire platinum resistance thermometer sensor Pt100 JIS C 1604-1997	
Rated temperature range	-100°C to +600°C	-148°F to +1112°F
Digital output	-1000 to +6000	-1480 to +11120
Resolution	0.2°C to 0.3°C	0.4°F to 0.5°F
Total accuracy	<ul style="list-style-type: none"> ±0.5% for full scale (when ambient temperature is 25°C±5°C) ±1.0% for full scale (when ambient temperature is in the range from 0 to 55°C) 	
A/D conversion time	<ul style="list-style-type: none"> FX3U/FX3UC Series PLC : 200μs (The data will be updated at every scan time.) FX3G Series PLC : 250μs (The data will be updated at every scan time.) →For a detailed description of data update, refer to Section 2.4.	
Input characteristics		
Insulation method	<ul style="list-style-type: none"> The photocoupler is used to insulate the analog input area from the PLC. The DC/DC converter is used to insulate the power supply line from the analog input area. Channels are not insulated from each other. 	
Number of I/O points occupied	0 points (This number is not related to the maximum number of input/output points of the PLC.)	

2.4 A/D Conversion Time

This section describes the A/D conversion time.

2.4.1 When connected to a FX3U, FX3UC PLC

1. A/D conversion and special data register update timing

A/D conversion is performed at every scan time of the PLC.

During execution of END instruction, the PLC performs A/D conversion, reads out the A/D converted data, and then writes the data in the special data registers.

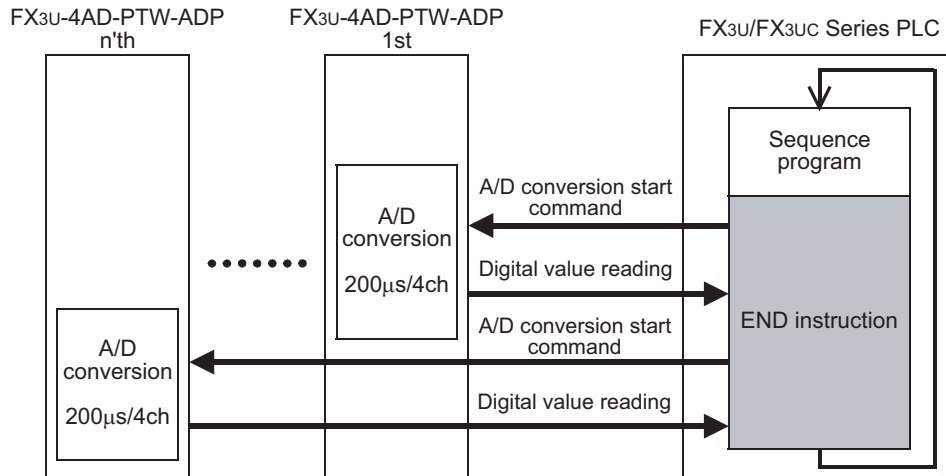

2. A/D conversion during PLC stop

Even if the PLC is stopped, A/D conversion will be performed and the special data registers will be updated.

3. If two or more analog special adapters are connected

During execution of the END instruction, data will be read out from all the connected adapters (in the order of 1st adapter → 2nd adapter ... 4th adapter).

4. A/D conversion speed (data update time)

During execution of the END instruction, the A/D converted data of all 4 channels will be read out in 200µs, and the data read out will be written to the special data registers.

END instruction execution time will be "200µs × number of connected adapters."

2.4.2 When connected to a FX3G PLC

1. A/D conversion and special data register update timing

A/D conversion is performed at every scan time of the PLC.

During execution of END instruction, the PLC performs A/D conversion, reads out the A/D converted data, and then writes the data in the special data registers.

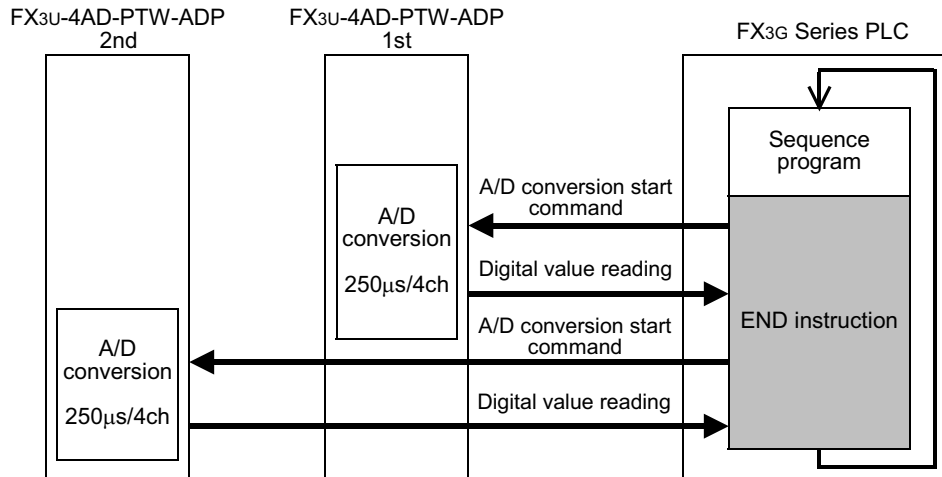

2. A/D conversion during PLC stop

Even if the PLC is stopped, A/D conversion will be performed and the special data registers will be updated.

3. If two analog special adapters are connected

During execution of the END instruction, data will be read out from all the connected adapters (in the order of 1st adapter → 2nd adapter).

4. A/D conversion speed (data update time)

During execution of the END instruction, the A/D converted data of all 4 channels will be read out in 250μs, and the data read out will be written to the special data registers.

END instruction execution time will be "250μs × number of connected adapters."

2.5 Temperature Measurement

To stabilize the temperature measurement, warm-up the system for 30 minutes or more after power-on.

A
Common Items

B
FX3U-4AD
FX3UC-4AD

C
FX3U-4AD-ADP

D
FX3G-2AD-BD

E
FX3U-4DA

F
FX3U-4DA-ADP

G
FX3G-1DA-BD

H
FX3U-3A-ADP

I
FX3U-4AD-PT
-ADP

J
FX3U-4AD-PTW
-ADP

3. Wiring

This chapter describes the PTW-ADP wiring.
Observe the following caution to wire the PTW-ADP.

WIRING PRECAUTIONS



DANGER

- Make sure to cut off all phases of the power supply externally before attempting wiring work. Failure to do so may cause electric shock or damages to the product.

WIRING PRECAUTIONS



CAUTION

- Connect the DC power supply wiring to the dedicated terminals described in this manual. If an AC power supply is connected to a DC input/output terminal or DC power supply terminal, the PLC will be burnt out.
- Do not wire vacant terminals externally. Doing so may damage the product.
- Perform class D grounding (grounding resistance: 100Ω or less) to the grounding terminal on the main unit. Do not use common grounding with heavy electrical systems.
- When drilling screw holes or wiring, make sure cutting or wire debris does not enter the ventilation slits. Failure to do so may cause fire, equipment failures or malfunctions.
- Make sure to observe the following precautions in order to prevent malfunctions under the influence of noise:
 - Do not bundle the power line or twisted shielded cable together with or lay it close to the main circuit, high-voltage line, or load line. Otherwise, noise disturbance and/or surge induction are likely to take place. As a guideline, lay the control line at least 100mm (3.94") or more away from the main circuit, high-voltage line, or load line.
 - Ground the shield of the analog input/output cable at one point on the signal receiving side. However, do not use common grounding with heavy electrical systems.
- Make sure to properly wire to the European terminal board in accordance with the following precautions. Failure to do so may cause electric shock, equipment failures, a short-circuit, wire breakage, malfunctions, or damage to the product.
 - The disposal size of the cable end should follow the dimensions described in the manual.
 - Tightening torque should follow the specifications in the manual.
 - Twist the end of strand wire and make sure there are no loose wires.
 - Do not solder-plate the electric wire ends.
 - Do not connect more than the specified number of wires or electric wires of unspecified size.
 - Affix the electric wires so that neither the terminal block nor the connected parts are directly stressed.

3.1 Terminal Layout

The terminals of the PTW-ADP are arranged as follows:

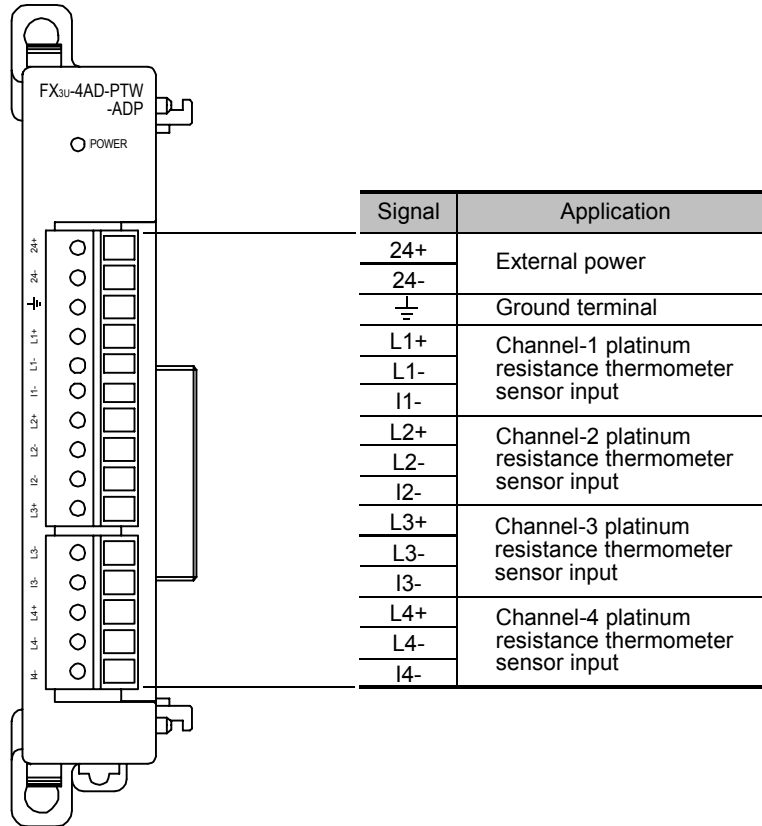

A
Common Items

B
FX3U-4AD
FX3UC-4AD

C
FX3U-4AD-ADP

D
FX3G-2AD-BD

E
FX3U-4DA

F
FX3U-4DA-ADP

G
FX3G-1DA-BD

H
FX3U-3A-ADP

I
FX3U-4AD-PT
-ADP

J
FX3U-4AD-PTW
-ADP

3.2 Applicable Cable and Terminal Tightening Torque

Use the following cables to connect with the counterpart equipment. Terminate the cable end as shown below. To connect the platinum resistance thermometer sensor, use the cable supplied with the Pt100 platinum resistance thermometer or a twisted pair shielded cable.

1. Cables

Applicable cable and tightening torque

	Wire size (stranded/single-wire)	Tightening torque	Termination
Single-wire	0.3mm ² to 0.5mm ² (AWG22 to 20)	0.22 N•m to 0.25 N•m	<ul style="list-style-type: none"> To connect a stranded cable, peel the cover off the cable and then twist the core before connection. To connect a single-wire cable, just strip the cover off the cable before connection.
2-wire	0.3mm ² (AWG22)		
Rod terminal with insulation sleeve	0.3mm ² to 0.5mm ² (AWG22 to 20) (Refer to the rod terminal external view shown in the following figure.)		<ul style="list-style-type: none"> Rod terminal with insulation sleeve (recommended terminal) AI 0.5-8WH : Manufactured by Phoenix Contact Caulking tool CRIMPFOX 6*1 : Manufactured by Phoenix Contact (or CRIMPFOX 6T-F*2 : Manufactured by Phoenix Contact)

*1. Old model name : CRIMPFOX ZA 3

*2. Old model name : CRIMPFOX UD 6

2. Termination of cable ends

To terminate the cable, treat the stranded/single wire directly or use a rod terminal with insulation sleeve.

- To directly terminate the end of a stranded/single-wire cable:
 - Twist the end of the stranded cable so that the "barbed wires" cannot protrude.
 - Do not solder-plate the end of the cable.

Termination of cable end

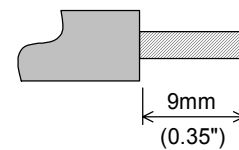

- To terminate cable end using a rod terminal with insulation sleeve:
 If the cable sheath is too thick, it may be difficult to insert the cable into the insulation sleeve. For this reason, select an appropriate cable while referring to the external view.
 <Reference>

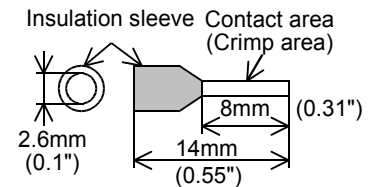

Manufacturer	Model	Caulking tool
Phoenix Contact	AI 0.5-8WH	CRIMPFOX 6*3 (or CRIMPFOX 6T-F*4)

*3. Old model name : CRIMPFOX ZA 3

*4. Old model name : CRIMPFOX UD 6

3. Tool

- To tighten terminals, use a small-sized screwdriver whose head is straight and is not widened as shown in the figure to the right.

Note:

If the diameter of screwdriver grip is too small, tightening torque will not be able to be achieved. To achieve the appropriate tightening torque shown in the table above, use the following screwdriver or an appropriate replacement (grip diameter: approximately 25mm (0.98")).
 <Reference>

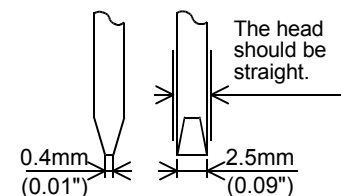

Manufacturer	Type
Phoenix Contact	SZS 0.4 × 2.5

3.3 Power Supply Line

Connect the 24V DC power supply line of the PTW-ADP to the 24+ and 24- terminals of the terminal block.

3.3.1 To connect to the FX3G, FX3U Series PLC

1. To use an external power

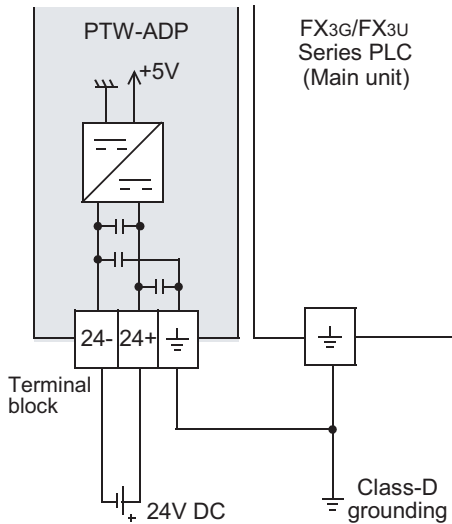

2. To use the 24V DC power of the PLC

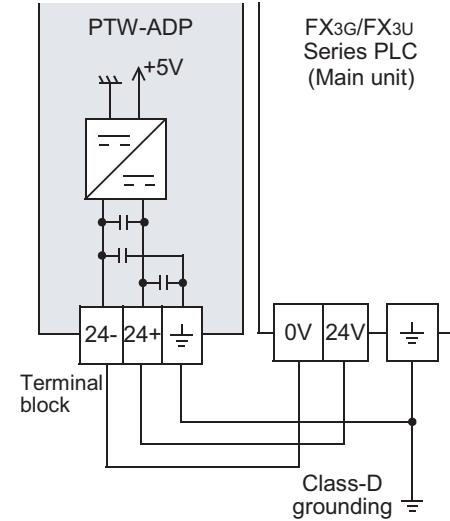

Caution regarding connection of the power supply line:

- Ground the "⊥" terminal to a class-D grounding power supply line (100Ω or less) together with the ground terminal of the PLC main unit.
- When using an external power supply, turn it ON at the same time with the main unit or earlier than the main unit. When turning OFF the power, confirm the safety of the system, and then turn OFF the power of the PLC (including special adapter) at the same time.

3.3.2 To connect to the FX3UC Series PLC

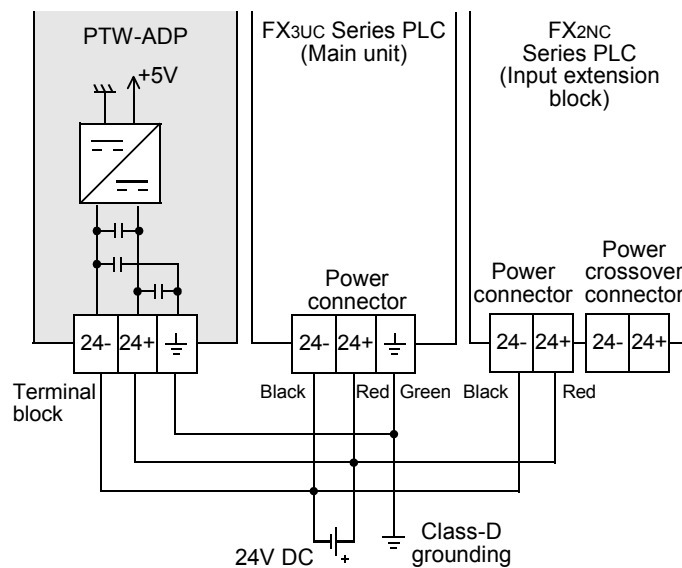

Caution regarding connection of the power supply line:

- For the 24V DC power supply line, be sure to use the same power as the FX3UC Series PLC.
- Ground the "⊥" terminal to a class-D grounding power supply line (100Ω or less) together with the grounding terminal of the PLC main unit.

3.4 Selection of the Platinum Resistance Thermometer Sensor

Select the Pt100 3-wire platinum resistance thermometer sensor.
 This thermometer will not be affected by voltage drop in the wiring area, and will ensure accurate measurement.

3.5 Wiring of the Platinum Resistance Thermometer Sensor

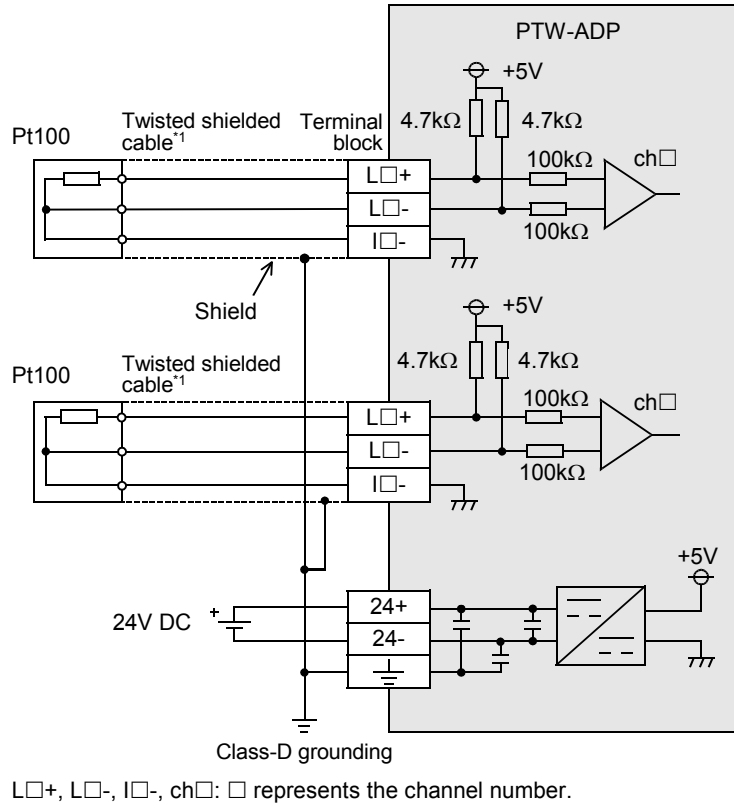

*1. Separate the cable of the platinum resistance thermometer sensor from the other power cables or areas easily affected by inductive noise (of the commercial power, etc.).

3.6 Grounding

Grounding should be performed as stated below.

- The grounding resistance should be 100Ω or less.
- Independent grounding should be performed for best results. When independent grounding is not performed, perform "shared grounding" as shown in the following figure.

→ For details, refer to the User's Manual - Hardware Edition of the PLC Series.

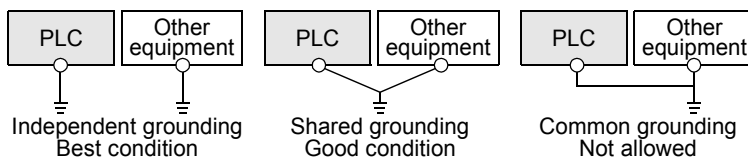

- The grounding wire size should be AWG22 to 20 (0.3 to 0.5 mm²).
- The grounding point should be close to the PLC, and all grounding wires should be as short as possible.

4. Programming

This chapter describes how to create programs that can read analog data using the PTW-ADP.

4.1 Loading of A/D Conversion Data

- 1) The input analog data will be converted into digital data and then stored in the special devices of the FX3U/FX3UC/FX3G Series PLC.
- 2) If data is stored in the special devices, the averaging time can be set, and the input mode can be specified.
- 3) Special auxiliary relays (10 points) and special data registers (10 points) are assigned automatically starting from the adapter nearest to the main unit.

→ For a detailed description of special device assignment, refer to Section 4.2.

- FX3U, FX3UC Series PLC

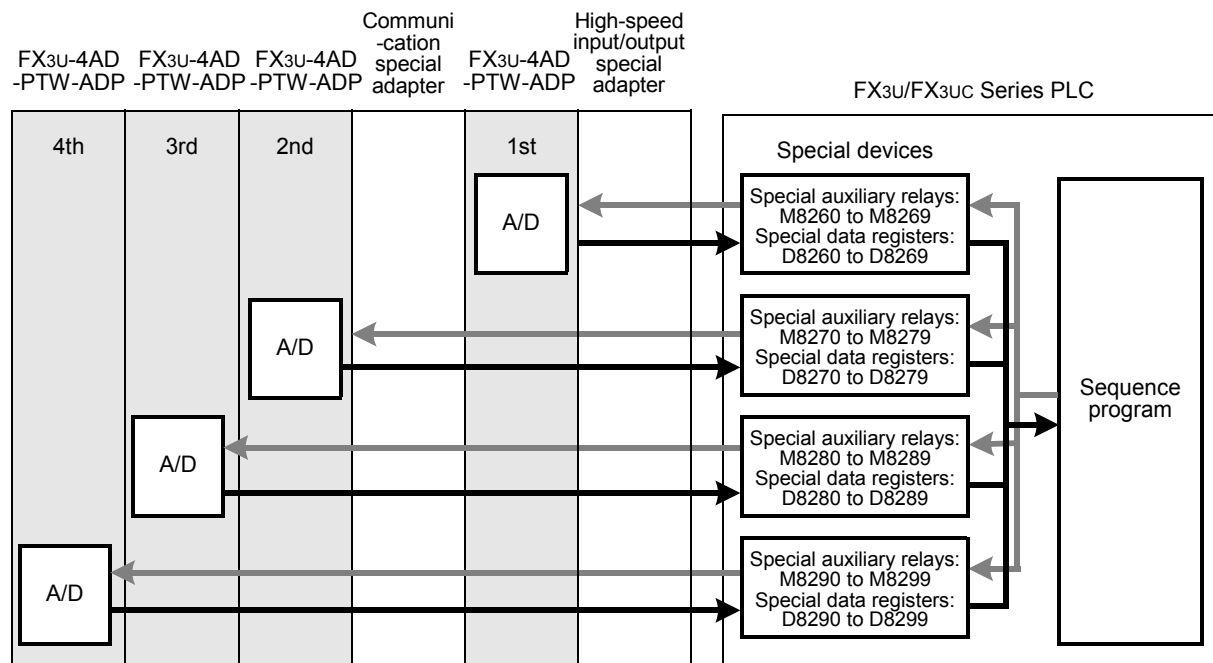

The analog special adapter nearest to the main unit is counted as the 1st analog special adapter, and the next adapter as the 2nd analog special adapter, and so on. However, in this case, do not include the high-speed input/output special adapter, communication special adapter, and the CF card special adapter.

• FX3G Series PLC

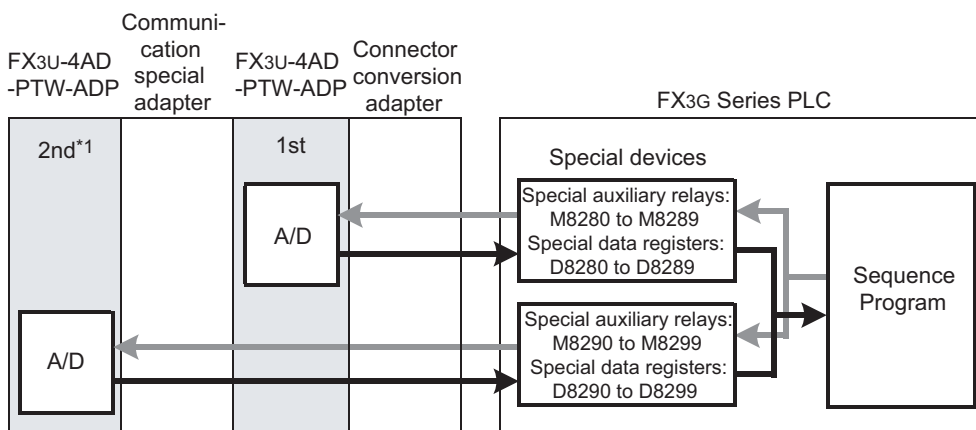

The analog special adapter nearest to the main unit is counted as the 1st analog special adapter, and the next adapter as the 2nd analog special adapter. However, in this case, do not include the connector conversion adapter and the communication special adapter.

*1. The second special adapter is not available in the FX3G Series PLC(14-point and 24-point type).

4.2 List of Special Devices

If the PTW-ADP is connected, special devices will be assigned automatically as shown in the following table:

- FX3U, FX3UC Series PLC

R: Read / W: Write

Special device	Device number				Description	Attribute	Reference
	1st	2nd	3rd	4th			
Special auxiliary relay	M8260	M8270	M8280	M8290	Selects the temperature unit.	R/W	Section 4.3
	M8261 to M8269	M8271 to M8279	M8281 to M8289	M8291 to M8299	Unused (Do not use.)	-	-
Special data register	D8260	D8270	D8280	D8290	Channel-1 temperature measurement data	R	Section 4.4
	D8261	D8271	D8281	D8291	Channel-2 temperature measurement data	R	
	D8262	D8272	D8282	D8292	Channel-3 temperature measurement data	R	
	D8263	D8273	D8283	D8293	Channel-4 temperature measurement data	R	
	D8264	D8274	D8284	D8294	Averaging time for channel 1 (Setting range: 1 to 4095)	R/W	Section 4.5
	D8265	D8275	D8285	D8295	Averaging time for channel 2 (Setting range: 1 to 4095)	R/W	
	D8266	D8276	D8286	D8296	Averaging time for channel 3 (Setting range: 1 to 4095)	R/W	
	D8267	D8277	D8287	D8297	Averaging time for channel 4 (Setting range: 1 to 4095)	R/W	
	D8268	D8278	D8288	D8298	Error status	R/W	Section 4.6
	D8269	D8279	D8289	D8299	Model code = 21	R	Section 4.7

A
Common Items

B
FX3U-4AD
FX3UC-4AD

C
FX3U-4AD-ADP

D
FX3G-2AD-BD

E
FX3U-4DA

F
FX3U-4DA-ADP

G
FX3G-1DA-BD

H
FX3U-3A-ADP

I
FX3U-4AD-PT
-ADP

J
FX3U-4AD-PTW
-ADP

- FX3G Series PLC

R: Read / W: Write

Special device	Device number		Description	Attribute	Reference
	1st	2nd			
Special auxiliary relay	M8280	M8290	Selects the temperature unit.	R/W	Section 4.3
	M8281 to M8289	M8291 to M8299	Unused (Do not use.)	-	-
Special data register	D8280	D8290	Channel-1 temperature measurement data	R	Section 4.4
	D8281	D8291	Channel-2 temperature measurement data	R	
	D8282	D8292	Channel-3 temperature measurement data	R	
	D8283	D8293	Channel-4 temperature measurement data	R	
	D8284	D8294	Averaging time for channel 1 (Setting range: 1 to 4095)	R/W	Section 4.5
	D8285	D8295	Averaging time for channel 2 (Setting range: 1 to 4095)	R/W	
	D8286	D8296	Averaging time for channel 3 (Setting range: 1 to 4095)	R/W	
	D8287	D8297	Averaging time for channel 4 (Setting range: 1 to 4095)	R/W	
	D8288	D8298	Error status	R/W	Section 4.6
	D8289	D8299	Model code = 21	R	Section 4.7

4.3 Selection of Temperature Unit

To switch the temperature unit of the PTW-ADP turn the special auxiliary relay ON for Fahrenheit (°F) or OFF for Centigrade (°C).

To switch the temperature unit, use the following special auxiliary relays:

- FX3U, FX3UC Series PLC

Special auxiliary relay				Description
1st	2nd	3rd	4th	
M8260	M8270	M8280	M8290	Selection of temperature unit: OFF: Centigrade (°C) ON: Fahrenheit (°F)

- FX3G Series PLC

Special auxiliary relay		Description
1st	2nd	
M8280	M8290	Selection of temperature unit: OFF: Centigrade (°C) ON: Fahrenheit (°F)

1. Program Example (For FX3U, FX3UC Series PLC)

1) To switch the temperature unit to centigrade (°C) for the 1st adapter:

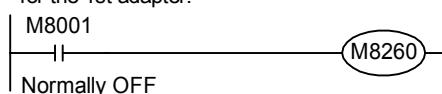

2) To switch the temperature unit to Fahrenheit (°F) for the 2nd adapter:

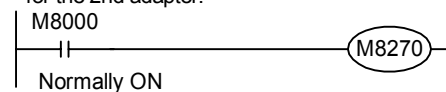

4.4 Temperature Measurement

The temperature data input in the PTW-ADP will be stored in the special data registers. The special data registers that store the temperature data are shown in the following table:

- FX3U, FX3UC Series PLC

Special data register				Description
1st	2nd	3rd	4th	
D8260	D8270	D8280	D8290	Stores the channel-1 temperature measurement data.
D8261	D8271	D8281	D8291	Stores the channel-2 temperature measurement data.
D8262	D8272	D8282	D8292	Stores the channel-3 temperature measurement data.
D8263	D8273	D8283	D8293	Stores the channel-4 temperature measurement data.

- FX3G Series PLC

Special data register		Description
1st	2nd	
D8280	D8290	Stores the channel-1 temperature measurement data.
D8281	D8291	Stores the channel-2 temperature measurement data.
D8282	D8292	Stores the channel-3 temperature measurement data.
D8283	D8293	Stores the channel-4 temperature measurement data.

The immediate data or the average data (data averaged in accordance with the specified averaging time) will be stored in the above data registers as the temperature measurement data.

→ For a detailed description of the averaging time, refer to Section 4.6.

1. Caution regarding temperature measurement

The special data registers for temperature measurement data are for reading only.

Do not change (rewrite) the current data using the sequence program, indicator, or device monitor of the programming tool.

2. Program Example (For FX3U, FX3UC Series PLC)

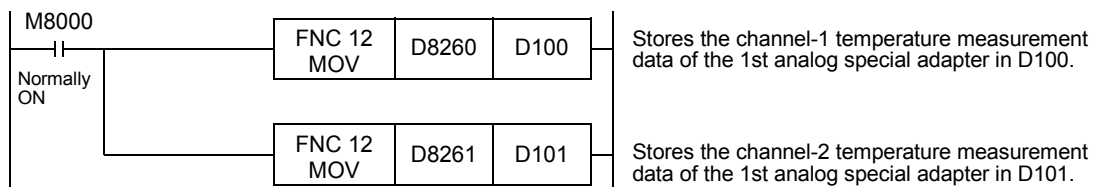

Even if the temperature measurement data is not stored in the D100 or the D101, the D8260 or the D8261 can be directly used in the arithmetic operation instruction or a PID instruction.

4.5 Averaging Time

Setting range: 1 to 4095
Initial value: K1
Numeric data type: Decimal (K)

If the averaging time is set for the PTW-ADP, the averaged temperature measurement data will be stored in the D8260 to D8263, D8270 to D8273, D8280 to D8283, and D8290 to D8293. The averaging time can be set for each channel.

Set the averaging time in the following special data registers:

- FX3U, FX3UC Series PLC

Special data register				Description
1st	2nd	3rd	4th	
D8264	D8274	D8284	D8294	Averaging time for channel-1 data
D8265	D8275	D8285	D8295	Averaging time for channel-2 data
D8266	D8276	D8286	D8296	Averaging time for channel-3 data
D8267	D8277	D8287	D8297	Averaging time for channel-4 data

- FX3G Series PLC

Special data register		Description
1st	2nd	
D8284	D8294	Averaging time for channel-1 data
D8285	D8295	Averaging time for channel-2 data
D8286	D8296	Averaging time for channel-3 data
D8287	D8297	Averaging time for channel-4 data

1. Cautions regarding averaging time setting

- If the averaging time is set to "1", the immediate data will be stored in the temperature measurement special data register.
- If the averaging time is set to "2" or more, the average value will be calculated in accordance with the set averaging time, and the average value obtained will be stored in the temperature measurement special data register.
- After turning the PLC power on, the average data will be stored in the temperature measurement special data registers (D8260 to D8263, D8270 to D8273, D8280 to D8283, and D8290 to D8293) until the number of data items is increased to the set averaging time.
- Set the averaging time in the range from 1 to 4095. If the set value is outside the setting range, the error signal will be output.
- If the averaging time is set to "0" or smaller, the PLC will perform as if the averaging time is set to "1".
 If the averaging time is set to "4096" or larger, the PLC will perform as if the averaging time is set to "4096".
 → For a detailed description of error status, refer to Section 5.5

2. Program Example (For FX3U, FX3UC Series PLC)

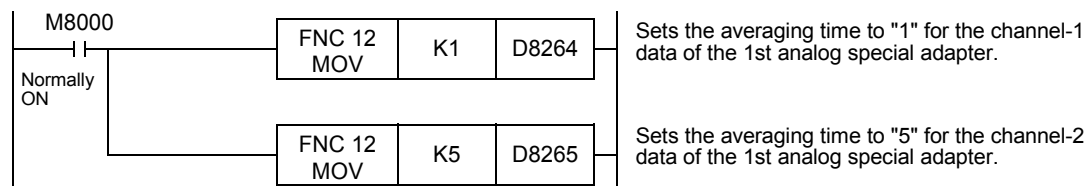

4.6 Error Status

If an error is detected in the PTW-ADP, the error status data will be stored in the corresponding special data register.

The following table shows the special data registers that store the error status data:

- FX3U, FX3UC Series PLC

Special data register				Description
1st	2nd	3rd	4th	
D8268	D8278	D8288	D8298	Stores the error status data.

- FX3G Series PLC

Special data register		Description
1st	2nd	
D8288	D8298	Stores the error status data.

Check the ON/OFF status of each bit of the error status data register to determine the error. Errors are assigned to the bits as shown in the following table. Create a program to detect errors.

Bit	Description	Bit	Description
b0	The temperature measurement data of channel 1 is outside the specified range, or disconnection is detected.	b5	Averaging time setting error
b1	The temperature measurement data of channel 2 is outside the specified range, or disconnection is detected.	b6	PTW-ADP hardware error
b2	The temperature measurement data of channel 3 is outside the specified range, or disconnection is detected.	b7	PTW-ADP communication data error
b3	The temperature measurement data of channel 4 is outside the specified range, or disconnection is detected.	b8 to b15	Unused
b4	EEPROM error	-	-

1. Caution regarding use of error status data

If a PTW-ADP hardware error (b6) or PTW-ADP communication data error (b7) is detected, it is necessary to clear the error status with a program at the next power-on of the PLC.

For this reason, be sure to create the following program:

- For FX3G, FX3U, FX3UC Series PLC

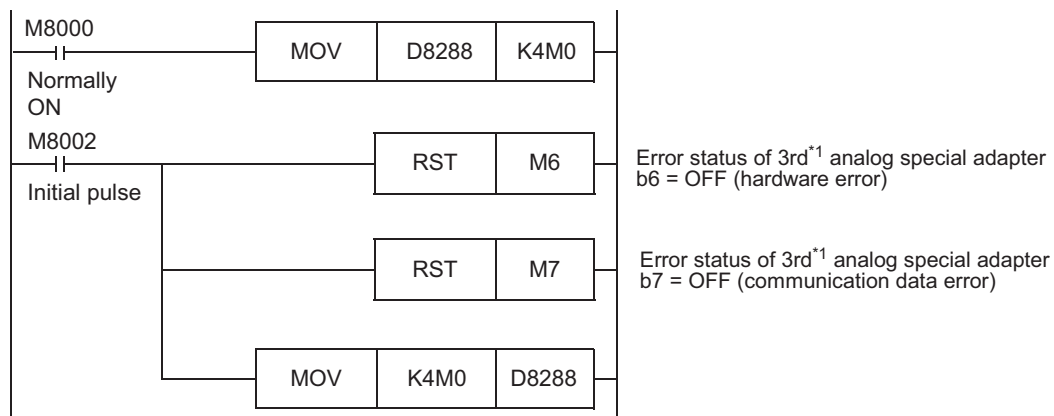

*1. "1st" for the FX3G PLC.

- For FX3U, FX3UC Series PLC

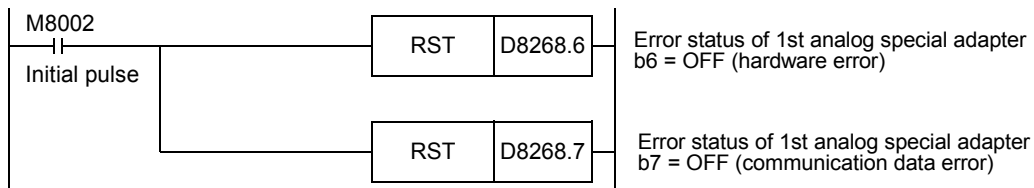

2. Program Example 1 (For FX3G, FX3U, FX3UC Series PLC)

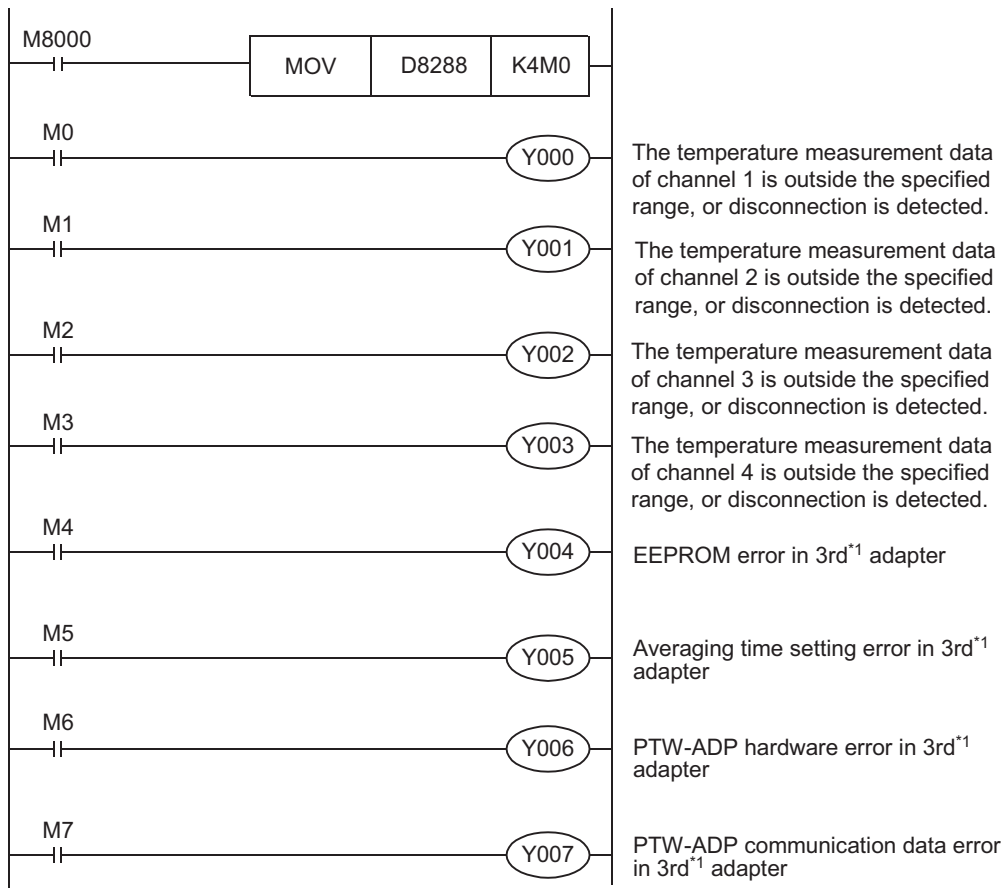

*1. "1st " for the FX3G PLC.

3. Program Example 2 (For FX3U, FX3UC Series PLC)

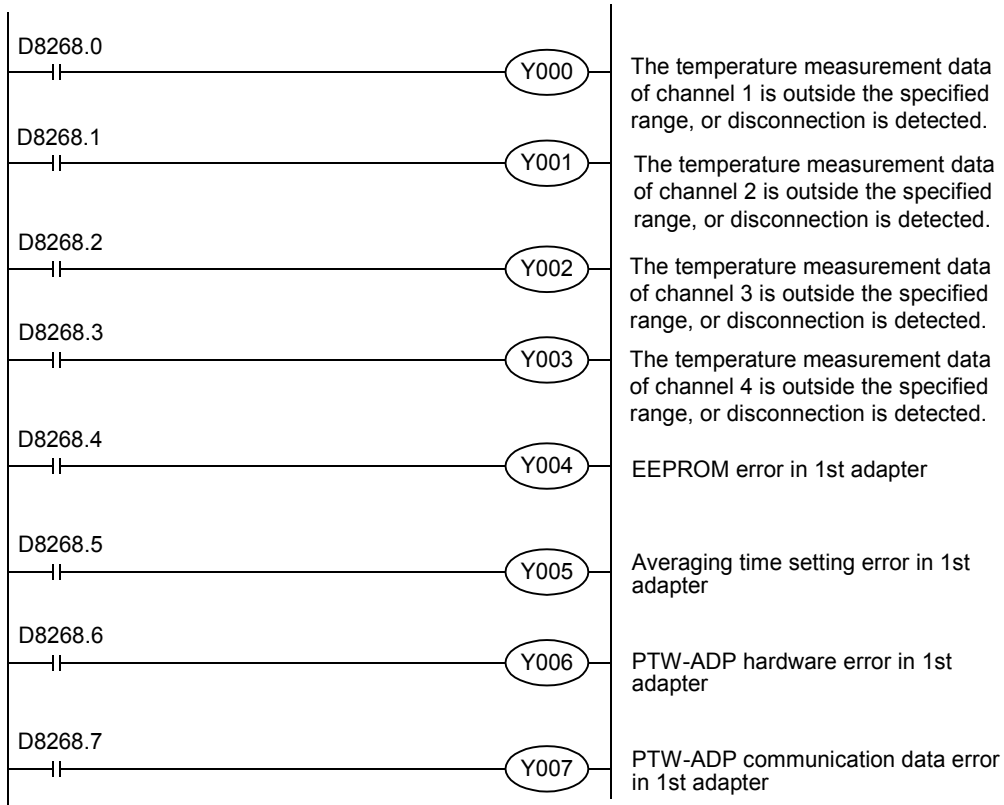

A
Common Items

B
FX3U-4AD
FX3UC-4AD

C
FX3U-4AD-ADP

D
FX3G-2AD-BD

E
FX3U-4DA

F
FX3U-4DA-ADP

G
FX3G-1DA-BD

H
FX3U-3A-ADP

I
FX3U-4AD-PT
-ADP

J
FX3U-4AD-PTW
-ADP

4.7 Model Code

Initial value: K21

Numeric data type: Decimal (K)

When the PTW-ADP is connected, model code "21" will be stored in the corresponding special data register. The following table shows the special data registers that store the model code:

- FX3U, FX3UC Series PLC

Special data register				Description
1st	2nd	3rd	4th	
D8269	D8279	D8289	D8299	Model code

- FX3G Series PLC

Special data register		Description
1st	2nd	
D8289	D8299	Model code

Use the special data registers above to check whether PTW-ADP is connected or not.

1. Program Example (For FX3U, FX3UC Series PLC)

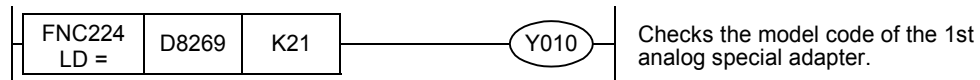

4.8 Basic Program Example

Create the following basic program example to read out the temperature measurement data.

- For FX3G, FX3U, FX3UC Series PLC

The following program will store the temperature measurement data (°C) from channels 1 and 2 of the 3rd¹ adapter to D100 and D101, respectively. The averaging time is set to "1" (immediate data) for channel 1, and "5" for channel 2.

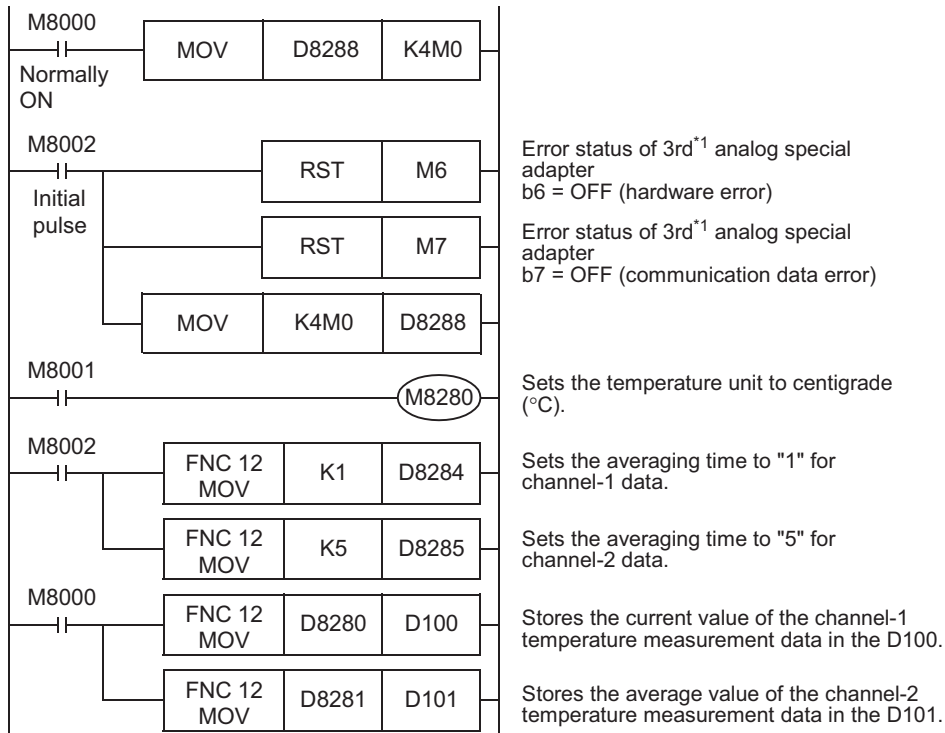

Even if the temperature measurement data is not stored in D100 or D101, data register D8280 or D8281 can be directly used in the arithmetic operation instruction or a PID instruction.

*1. "1st" for the FX3G PLC.

- For FX3U, FX3UC Series PLC

The following program will store the temperature measurement data (°C) from channels 1 and 2 of the 1st adapter to D100 and D101, respectively. The averaging time is set to "1" (immediate data) for channel 1, and "5" for channel 2.

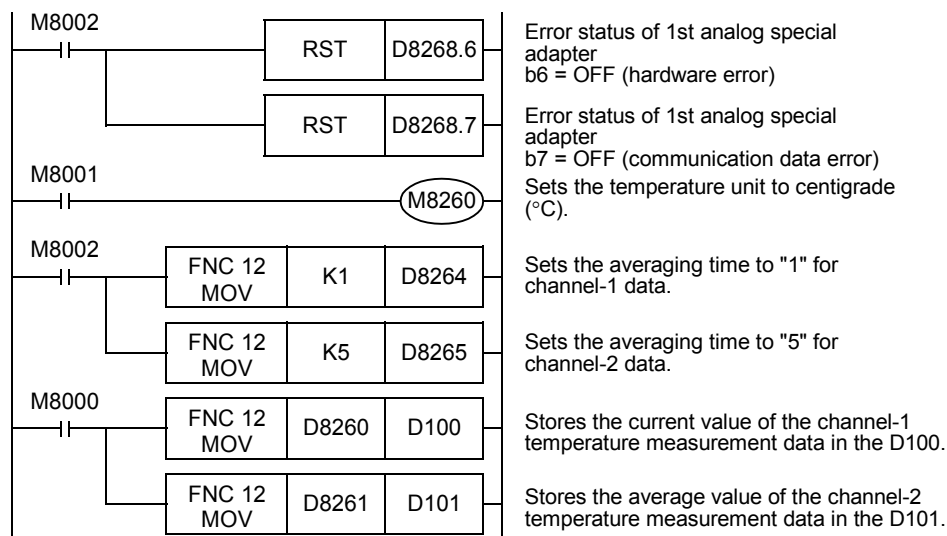

Even if the temperature measurement data is not stored in D100 or D101, data register D8260 or D8261 can be directly used in the arithmetic operation instruction or a PID instruction.

5. Troubleshooting

This chapter describes the troubleshooting methods and error status.

If the temperature measurement data is not input, or if the proper digital value is not input, check the following items:

- Version number of the PLC
- Wiring
- Special devices
- Programs
- Error status

5.1 PLC Version Number Check

- Any versions (from Ver.2.20 (initial version) to the latest version) of the FX3U Series are compatible.
- Check the version number of the FX3UC Series. The version number should be 1.30 or later.
- Any versions (from Ver.1.00 (initial version) to the latest version) of the FX3G Series are compatible.
→ **For a detailed description of the version number check method, refer to Section 1.3.**

5.2 Wiring Check

Check the following items for wiring:

1. Power

The PTW-ADP needs driving power. Verify that the power supply line is properly connected. Also check that the POWER indicator lamp of the PTW-ADP is on.

2. Platinum resistance thermometer sensor cable

Separate the cable of the platinum resistance thermometer from other power cables or inductive cables.

→ **For a detailed description of wiring, refer to Chapter 3.**

5.3 Special Device Check

Check whether the special devices for the PTW-ADP are correctly used:

1. Temperature measurement

Verify that the special device for the selected channel is correctly selected. This special device should be selected depending on the connecting position and the channel.

2. Averaging time

Check that the set averaging time is within the specified range. The averaging time should be set in the range from 1 to 4095. If the set averaging time is outside the specified range, an error occurs.

3. Error status

Check that no error is detected in the PTW-ADP.

If an error is detected, check the details of the error, and then check the wiring and programs.

→ **For a detailed description of special devices, refer to Chapter 4.**

5.4 Program Check

Check the following items for the program:

1. Cancellation of error status at power-on

When the power is turned off and then on again, the error status should be cleared (b6 and b7 should turn off) using the program.

2. Check of storage devices

Verify that different values are not being stored in the same device by the other parts of the programs.

5.5 Error Status Check

If an error occurs in the PTW-ADP, the corresponding bit will turn on.

The bit which is turned ON due to the error status is held ON until overwritten to OFF by the program or the power is cycled. If b6 or b7 is turned ON, then it is necessary to clear the error status using the program the next time the power of the PLC is cycled.

Bit	Description	Bit	Description
b0	The temperature measurement data of channel 1 is outside the specified range, or disconnection is detected.	b5	Averaging time setting error
b1	The temperature measurement data of channel 2 is outside the specified range, or disconnection is detected.	b6	PTW-ADP hardware error
b2	The temperature measurement data of channel 3 is outside the specified range, or disconnection is detected.	b7	PTW-ADP communication data error
b3	The temperature measurement data of channel 4 is outside the specified range, or disconnection is detected.	b8 to 15	Unused
b4	EEPROM error	-	-

To solve a problem, refer to the troubleshooting method described below:

1. Temperature measurement out of specified range or disconnection of line (b0 to b3)

1) Description of error

The input temperature measurement value is outside the specified range.
 The temperature measurement value is not in the range between -115°C to 615°C.
 Or the line between PTW-ADP and the platinum resistance thermometer sensor is disconnected.

2) Remedy

Check that the input temperature measurement value is within the specified range. Also check the wiring condition.

2. EEPROM error (b4)

1) Description of error

The adjustment data set in the EEPROM before delivery from our factory cannot be read out properly or is destroyed.

2) Remedy

Please contact the nearest Mitsubishi Electric distributor office.

3. Averaging time setting error (b5)

1) Description of error

The averaging time set for one of the channels (channels 1 to 4) is outside the specified range: 1 to 4095.

2) Remedy

Check that the averaging time is correctly set for each channel.

4. PTW-ADP hardware error (b6)

- 1) Description of error
The PTW-ADP does not operate properly.
- 2) Remedy
Check that the 24V DC power is properly supplied to the PTW-ADP. Also check that the PTW-ADP is correctly connected to the PLC.
If the problem cannot be solved even after the above check, please contact the nearest Mitsubishi Electric distributor office.

5. PTW-ADP communication data error (b7)

- 1) Description of error
A communication error is detected between the PTW-ADP and the PLC.
- 2) Remedy
Check that the PTW-ADP is correctly connected to the PLC.
If the problem cannot be solved even after the above check, please contact the nearest Mitsubishi Electric distributor office.

FX3G/FX3U/FX3UC Series Programmable Controllers

User's Manual [Analog Control Edition] FX3U-4AD-PNK-ADP (4-channel Resistance Thermometer Data Input)

Foreword

This manual describes the specifications, wiring, and operation methods for the FX3U-4AD-PNK-ADP special adapter (4-channel resistance thermometer data input) and should be read and understood before attempting to install or use the unit.

Store this manual in a safe place so that you can take it out and read it whenever necessary. Always forward it to the end user.

This manual confers no industrial property rights or any rights of any other kind, nor does it confer any patent licenses. Mitsubishi Electric Corporation cannot be held responsible for any problems involving industrial property rights which may occur as a result of using the contents noted in this manual.

© 2005 MITSUBISHI ELECTRIC CORPORATION

1. Outline

This chapter describes the outline of FX3U-4AD-PNK-ADP (referred to as PNK-ADP).

1.1 Outline of Functions

The FX3U-4AD-PNK-ADP is an analog special adapter. Connect the FX3U-4AD-PNK-ADP to the FX3G/FX3U/FX3UC Series PLC to read the data from the 4-channel resistance thermometer.

- 1) Up to 4 PNK-ADP units can be connected to the FX3U/FX3UC Series PLC.
 Up to 2*¹ PNK-ADP units can be connected to the FX3G Series PLC.
 (Including other analog special adapters)
- 2) Thermometer types Pt1000 and Ni1000 can be connected. (However, it's impossible to use both types Pt1000 and Ni1000 with 1 adapter.)
- 3) The temperature data will be automatically written to the special data register of the FX3G/FX3U/FX3UC Series PLC.

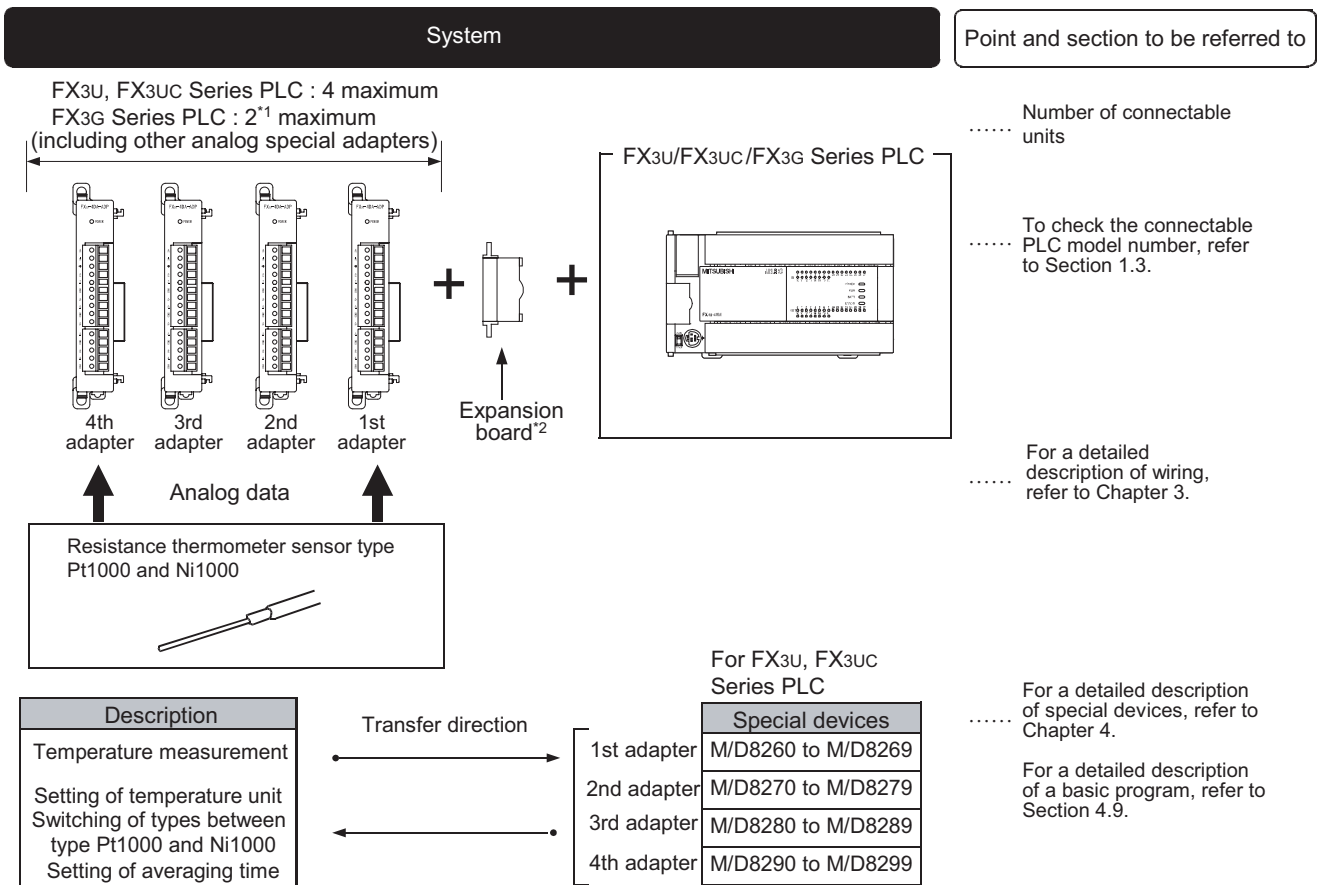

Refer to the system configuration shown in the User's Manual - Hardware Edition to check the number of connectable units and to configure the entire system.

*1. Only 1 analog special adapter can be connected to the 14-point and 24-point type main unit.

*2. The expansion board is not required when connecting with the FX3UC (D, DSS) PLC.
 For the FX3G Series PLC a connector conversion adapter is used.

1.2 Setup Procedure Before Starting Operation

Before starting analog input using PNK-ADP, follow the procedure below to set up the system:

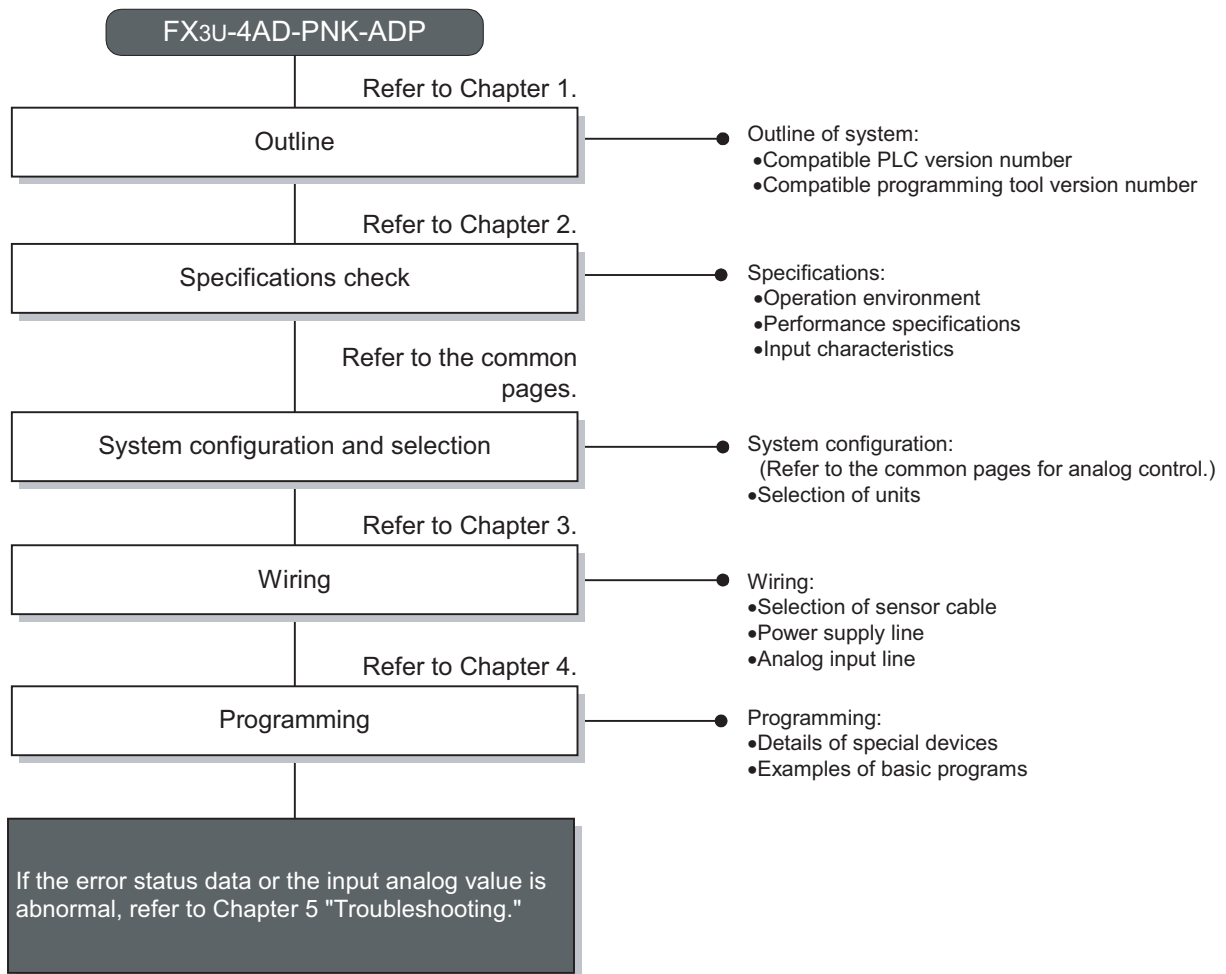

1.3 Connectable PLC and Its Version Number

PNK-ADP is compatible with the following PLC.

Compatible PLC	Version number	Date of production
FX3U Series PLC	Ver. 2.20 or later	After May 2005 (initial production)
FX3UC Series PLC	Ver. 1.30 or later	After August 2004
FX3G Series PLC	Ver. 1.00 or later	After June 2008 (initial production)

1. Version check

Special data register D8001 contains information for determining the PLC version number.

→ For a detailed description of the version check, refer to A. Common Items Subsection 5.1.2.

2. How to check the manufacturer's serial number

The year and month of production of the product can be checked on the nameplate, and on the front of the product.

→ For a detailed description of how to check the manufacturer's serial number, refer to A. Common Items Subsection 5.1.1.

1.4 Compatible Programming Tool Version Number

Use the programming tool having the following version number to create programs for PNK-ADP:

1. GX Works2

Software	Version number	Remarks
GX Works2 SW□DNC-GXW2-J	Ver. 1.07H or later	-
GX Works2 SW□DNC-GXW2-E	Ver. 1.08J or later	-

2. GX Developer

- FX3U/FX3UC Series PLC

Software	Version number	Remarks
GX Developer SW□D5C-GPPW-J	Ver. 8.13P or later	When selecting the model, select FX3U(C) ^{*1} .
GX Developer SW□D5C-GPPW-E	Ver. 8.18U or later	

- FX3G Series PLC

Software	Version number	Remarks
GX Developer • SW□D5C-GPPW-J • SW□D5C-GPPW-E	Ver. 8.72A or later	-

If a programming tool with the wrong version number is used, programming will not be possible.

*1. For Ver. 8.13P to 8.24A of GX Developer, select FX3UC for the PLC type.

3. FX-30P

Model name	Version number	Remarks
FX-30P	Ver. 1.00 or later	-

2. Specifications

This chapter describes the general, power supply, and performance specifications for the PNK-ADP.

2.1 Generic Specifications

Item	Specifications				
Ambient temperature	0 to 55°C (32 to 131°F) when operating -25 to 75°C (-13 to 167°F) when stored				
Relative humidity	5 to 95%RH (no condensation) when operating				
Vibration resistance *1		Frequency (Hz)	Acceleration (m/s ²)	Half amplitude (mm)	Tested 10 times in each direction (X-, Y-, and Z-axis directions) (Total: 80 min, each)
	DIN Rail Mounting	10 - 57	-	0.035	
		57 - 150	4.9	-	
	Direct Mounting *2	10 to 57	-	0.075	
57 to 150		9.8	-		
Shock resistance *1	147 m/s ² Acceleration, Action time: 11ms, 3 times by half-sine pulse in each direction X, Y, and Z				
Noise resistance	Using noise simulator of: Noise voltage: 1,000Vp-p / Noise width: 1μs / Rise: 1ns / Cycle: 30 to 100Hz				
Dielectric withstand voltage	500 V AC, for 1 min		Between batch of all terminals and ground terminal		
Insulation resistance	5MΩ or more using 500V DC insulation resistance meter				
Grounding	Class D grounding (grounding resistance: 100 Ω or less) <Common grounding with a heavy electrical system is not allowed.>*3				
Working environment	Free from corrosive or flammable gas and excessive conductive dusts				
Working altitude	< 2000m*4				

*1. The criterion is shown in IEC61131-2.

*2. If PNK-ADP is connected to the FX3UC Series PLC, direct installation is not possible.

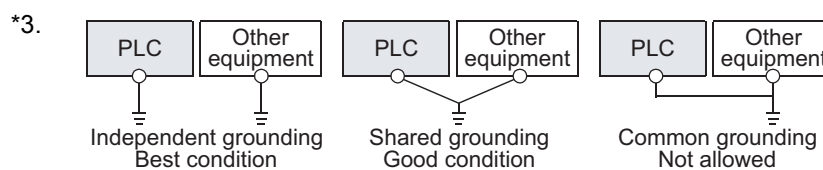

→ For a detailed description of the grounding, refer to Section 3.7.

*4. If the pressure is higher than the atmospheric pressure, do not use the PNK-ADP.
 The PNK-ADP may malfunction.

2.2 Power Supply Specifications

Item	Specifications
A/D conversion circuit driving power	24V DC +20% -15%, 45mA (It is necessary to connect a 24V DC power supply to the terminal block.)
Interface driving power	5V DC, 15mA (Since the internal power is supplied from the FX Series main unit, it is not necessary to supply the power.)

2.3 Performance Specifications

Item	Specifications			
	Centigrade (°C)		Fahrenheit (°F)	
Input signal	Platinum resistance thermometer sensor (2-wire or 3-wire) Pt1000 JIS C 1604-1997 Nickel resistance thermometer sensor (2-wire or 3-wire) Ni1000 DIN 43760-1987			
Rated temperature range	Pt1000	-50°C to +250°C	Pt1000	-58°F to +482°F
	Ni1000	-40°C to +110°C	Ni1000	-40°F to +230°F
Digital output	Pt1000	-500 to +2500	Pt1000	-580 to +4820
	Ni1000	-400 to +1100	Ni1000	-400 to +2300
Resolution	Pt1000	0.1°C	Pt1000	0.2°F
	Ni1000		Ni1000	
Total accuracy	±0.5% for full scale (when ambient temperature is 25°C±5°C) ±1.0% for full scale (when ambient temperature is in the range of 0 to 55°C)			
A/D conversion time	<ul style="list-style-type: none"> FX3U/FX3UC Series PLC : 200μs (The data will be updated at every scan time.) FX3G PLC : 250μs (The data will be updated at every scan time.) →For a detailed description of data update, refer to Section2.4.			
Input characteristics				
Insulation method	<ul style="list-style-type: none"> The photocoupler is used to insulate the analog input area from the PLC. The DC/DC converter is used to insulate the power supply line from the analog input area. Channels are not insulated from each other. 			
Number of I/O points occupied	0 points (This number is not related to the maximum number of input/output points of the PLC.)			

K
 FX3U-4AD-PNK-ADP
 FX3U-4AD-TC-ADP
 M
 PID Instruction (FNC 88)

2.4 A/D Conversion Time

This section describes the A/D conversion time.

2.4.1 When connected to a FX3U, FX3UC PLC

1. A/D conversion and special data register update timing

A/D conversion is performed at every arithmetic operation of the PLC.

During execution of END instruction, the PLC performs A/D conversion, reads out the A/D converted data, and then writes the data in the special data registers.

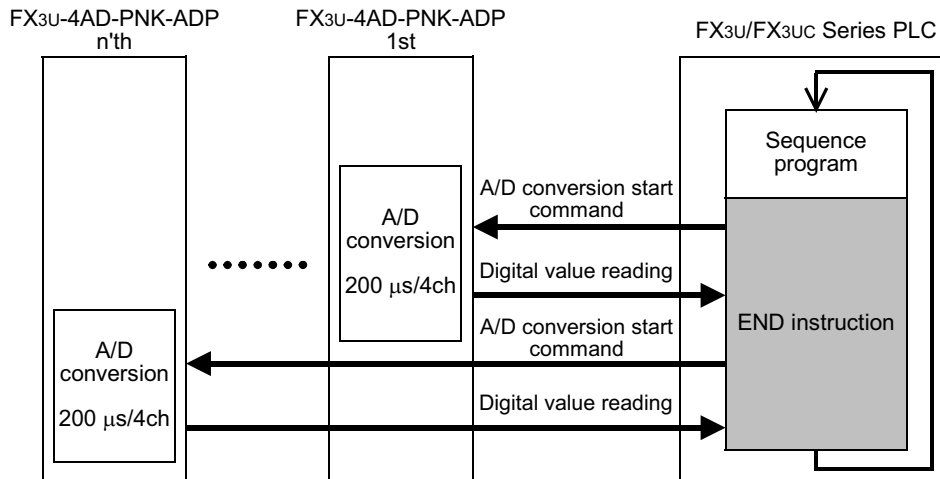

2. A/D conversion during PLC stop

Even if the PLC is stopped, A/D conversion will be performed and the special data registers will be updated.

3. If two or more analog special adapters are connected

During execution of the END instruction, data will be read out from all the connected adapters (in the order of 1st adapter → 2nd adapter...4th adapter).

4. A/D conversion speed (data update time)

During execution of the END instruction, the A/D converted data of all 4 channels will be read out in 200μs, and the data read out will be written to the special data registers.

END instruction execution time will be "200μs × number of connected adapters."

2.4.2 When connected to a FX3G PLC

1. A/D conversion and special data register update timing

A/D conversion is performed at every scan time of the PLC.

During execution of END instruction, the PLC performs A/D conversion, reads out the A/D converted data, and then writes the data in the special data registers.

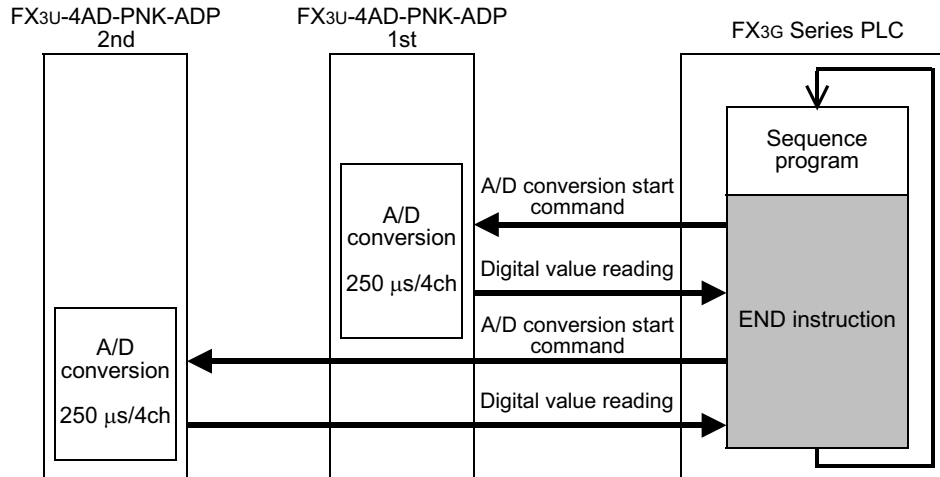

2. A/D conversion during PLC stop

Even if the PLC is stopped, A/D conversion will be performed and the special data registers will be updated.

3. If two analog special adapters are connected

During execution of the END instruction, data will be read out from all the connected adapters (in the order of 1st adapter → 2nd adapter).

4. A/D conversion speed (data update time)

During execution of the END instruction, the A/D converted data of all 4 channels will be read out in 250μs, and the data read out will be written to the special data registers.

END instruction execution time will be "250μs × number of connected adapters."

2.5 Temperature Measurement

To stabilize the temperature measurement, warm-up the system for 30 minutes or more after power-on.

3. Wiring

This chapter describes the PNK-ADP wiring.
Observe the following caution to wire the PNK-ADP.

WIRING PRECAUTIONS



DANGER

- Make sure to cut off all phases of the power supply externally before attempting wiring work. Failure to do so may cause electric shock or damages to the product.

WIRING PRECAUTIONS



CAUTION

- Connect the DC power supply wiring to the dedicated terminals described in this manual. If an AC power supply is connected to a DC input/output terminal or DC power supply terminal, the PLC will be burnt out.
- Do not wire vacant terminals externally. Doing so may damage the product.
- Perform class D grounding (grounding resistance: 100Ω or less) to the grounding terminal on the main unit. Do not use common grounding with heavy electrical systems.
- When drilling screw holes or wiring, make sure cutting or wire debris does not enter the ventilation slits. Failure to do so may cause fire, equipment failures or malfunctions.
- Make sure to observe the following precautions in order to prevent malfunctions under the influence of noise:
 - Do not bundle the power line or twisted shielded cable together with or lay it close to the main circuit, high-voltage line, or load line. Otherwise, noise disturbance and/or surge induction are likely to take place. As a guideline, lay the control line at least 100mm (3.94") or more away from the main circuit, high-voltage line, or load line.
 - Ground the shield of the analog input/output cable at one point on the signal receiving side. However, do not use common grounding with heavy electrical systems.
- Make sure to properly wire to the European terminal board in accordance with the following precautions. Failure to do so may cause electric shock, equipment failures, a short-circuit, wire breakage, malfunctions, or damage to the product.
 - The disposal size of the cable end should follow the dimensions described in the manual.
 - Tightening torque should follow the specifications in the manual.
 - Twist the end of strand wire and make sure there are no loose wires.
 - Do not solder-plate the electric wire ends.
 - Do not connect more than the specified number of wires or electric wires of unspecified size.
 - Affix the electric wires so that neither the terminal block nor the connected parts are directly stressed.

3.1 Terminal Layout

The terminals of the PNK-ADP are arranged as follows:

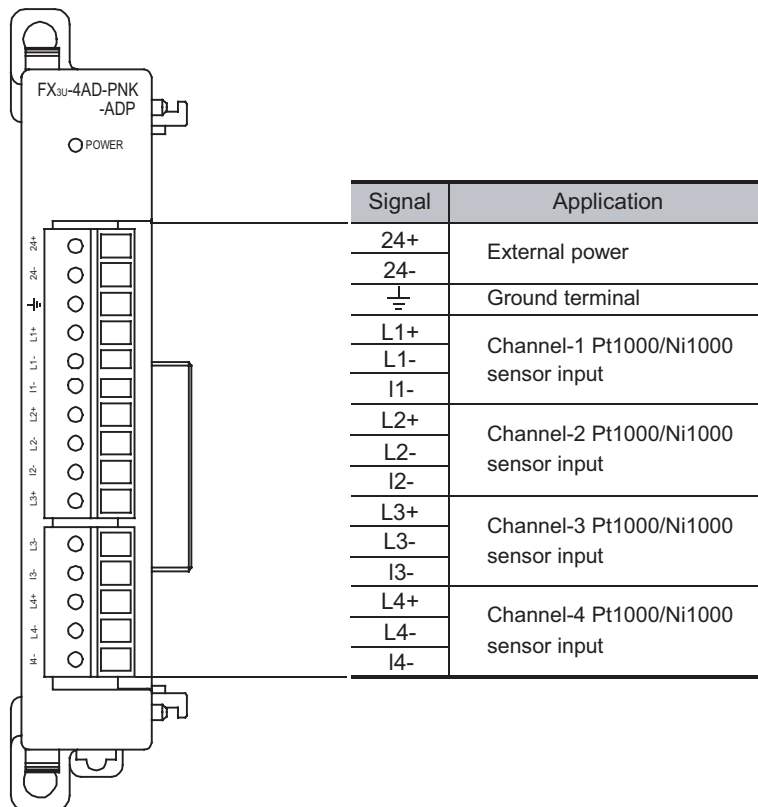

3.2 Applicable Cables and Terminal Tightening Torque

Use the following cables to connect with the counterpart equipment. Terminate the cable end as shown below.

1. Cables

Applicable cable and tightening torque

	Wire size (stranded/single-wire)	Tightening torque	Termination
Single-wire	0.3 mm ² to 0.5 mm ² (AWG22 to 20)	0.22 N•m to 0.25 N•m	<ul style="list-style-type: none"> To connect a stranded cable, peel the cover off the cable and then twist the core before connection. To connect a single-wire cable, just strip the cover off the cable before connection.
2-wire	0.3mm ² (AWG22)		
Rod terminal with insulation sleeve	0.3 mm ² to 0.5 mm ² (AWG22-20) (Refer to the rod terminal external view shown in the following figure.)		<ul style="list-style-type: none"> Rod terminal with insulation sleeve (recommended terminal) AI 0.5-8WH : Manufactured by Phoenix Contact Caulking tool CRIMPFOX 6*1 : Manufactured by Phoenix Contact (or CRIMPFOX 6T-F*2 : Manufactured by Phoenix Contact)

- *1. Old model name : CRIMPFOX ZA 3
- *2. Old model name : CRIMPFOX UD 6

2. Termination of cable end

To terminate the cable, treat the stranded/single wire directly or use a rod terminal with insulation sleeve.

- To directly terminate the end of a stranded/single-wire cable:
 - Twist the end of the stranded cable so that the "barbed wires" cannot protrude.
 - Do not solder-plate the end of the cable.

Termination of cable end

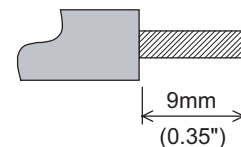

- To terminate cable end using a rod terminal with insulation sleeve:
 If the cable cover is too thick, it may be difficult to insert the cable into the insulation sleeve. For this reason, select an appropriate cable while referring to the external view.

<Reference>

Manufacturer	Model	Caulking tool
Phoenix Contact	AI 0.5-8WH	CRIMPFOX 6*3 (or CRIMPFOX 6T-F*4)

- *3. Old model name : CRIMPFOX ZA 3
- *4. Old model name : CRIMPFOX UD 6

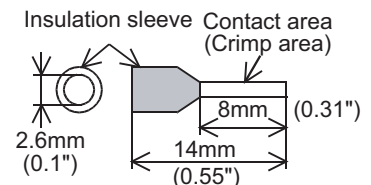

3. Tool

- To tighten terminals, use a small-sized screwdriver whose head is straight and is not widened as shown in the figure to the right.

Note:

If the diameter of screwdriver grip is too small, tightening torque will not be able to be achieved. To achieve the appropriate tightening torque shown in the table above, use the following screwdriver or an appropriate replacement (grip diameter: approximately 25mm (0.98")).

<Reference>

Manufacturer	Model
Phoenix Contact	SZS 0.4×2.5

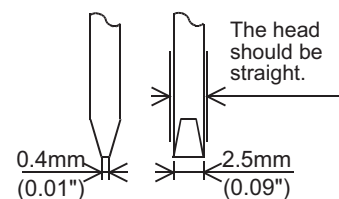

3.3 Power Supply Line

Connect the 24V DC power supply line of the PNK-ADP to the 24+ and 24- terminals of the terminal block.

3.3.1 To connect to the FX3G, FX3U Series PLC

1. To use an external power

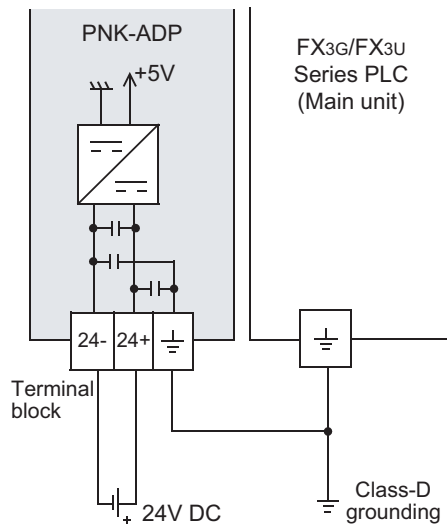

2. To use the 24V DC power of the PLC

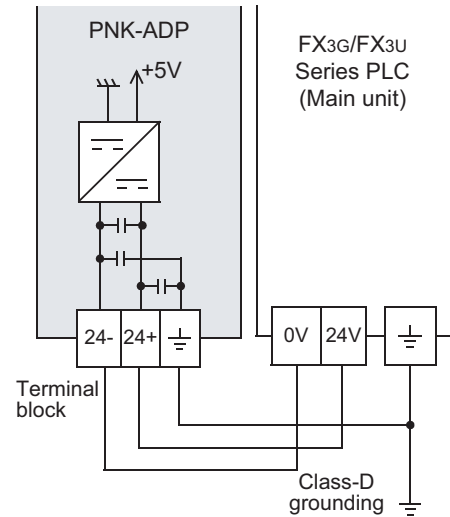

Caution regarding connection of the power supply line:

- Ground the "⏏" terminal to a class-D grounding power supply line (100Ω or less) together with the grounding terminal of the PLC main unit.
- When using an external power supply, turn it ON at the same time with the main unit or earlier than the main unit. When turning OFF the power, confirm the safety of the system, and then turn OFF the power of the PLC (including special adapter) at the same time.

3.3.2 To connect to the FX3UC Series PLC

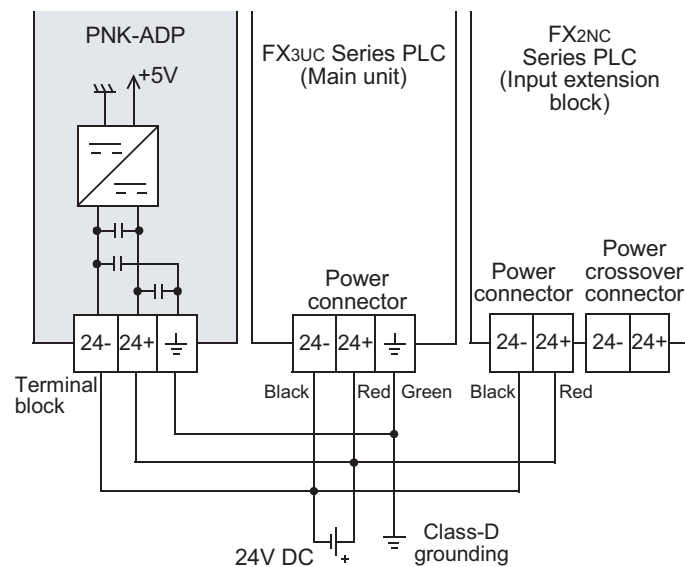

Cautions regarding connection of the power supply line:

- For the 24V DC power supply line, be sure to use the same power as the FX3UC Series PLC.
- Ground the "⏏" terminal to a class-D grounding power supply line (100Ω or less) together with the ground terminal of the PLC main unit.

3.4 Selection of the Resistance Thermometer Sensor

Select the Pt1000/Ni1000 (2-wire or 3-wire sensors) resistance thermometer sensor.

3.5 Wiring of the Resistance Thermometer Sensor

Wiring depends on the resistance thermometer sensor type selected. Refer to the following wiring diagrams:

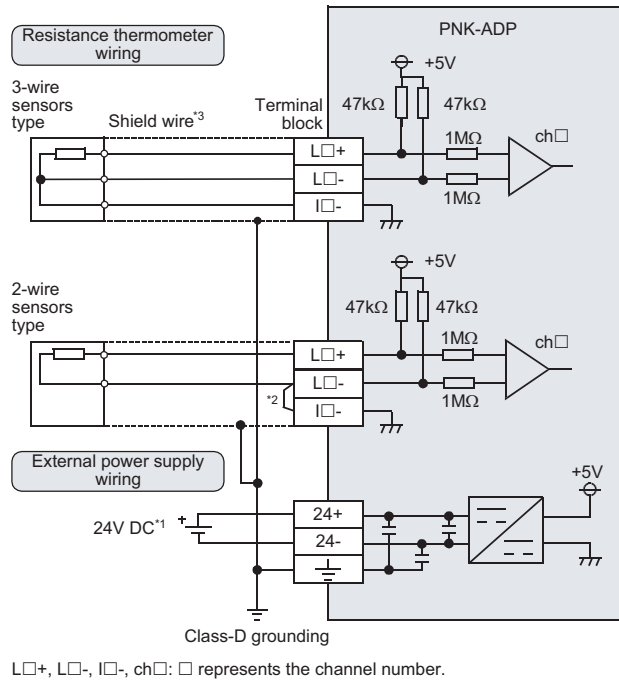

- *1. 24V DC service power supply of the FX3G/FX3U Series PLC can also be used.
- *2. When using a 2-wire temperature sensor type, short-circuit the [L□ -] terminal and the [I□ -] terminal. For the lead wire use a 10Ω resistance or less per line.
- *3. Separate the cable of the platinum resistance thermometer sensor from the other power cables or areas easily affected by inductive noise (of the commercial power, etc.).

3.6 Caution Regarding Wiring

- It is not possible to connect different types of resistance thermometer to 4 channels of PNK-ADP. Be sure to use the same type of resistance thermometer for all the channels.

3.7 Grounding

Grounding should be performed as stated below.

- The grounding resistance should be 100Ω or less.
- Independent grounding should be performed for best results. When independent grounding is not performed, perform "shared grounding" as shown in the following figure.

→ For details, refer to the User's Manual - Hardware Edition of the PLC Series.

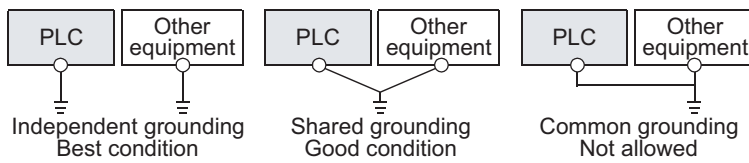

- The grounding wire size should be AWG22 to 20 (0.3 to 0.5 mm^2).
- The grounding point should be close to the PLC, and all grounding wires should be as short as possible.

4. Programming

This chapter describes how to create programs that can read out the analog data using the PNK-ADP.

4.1 Loading of A/D Conversion Data

- 1) The input analog data will be converted into digital data and then stored in the special devices of the FX3U/FX3UC/FX3G Series PLC.
 - 2) If data is stored in the special devices, the averaging time can be set, and the input mode can be specified.
 - 3) Special auxiliary relays (10 points) and special data registers (10 points) are assigned automatically starting from the adapter nearest to the main unit.
 → For a detailed description of special device assignment, refer to Subsection 4.2.
- FX3U, FX3UC Series PLC

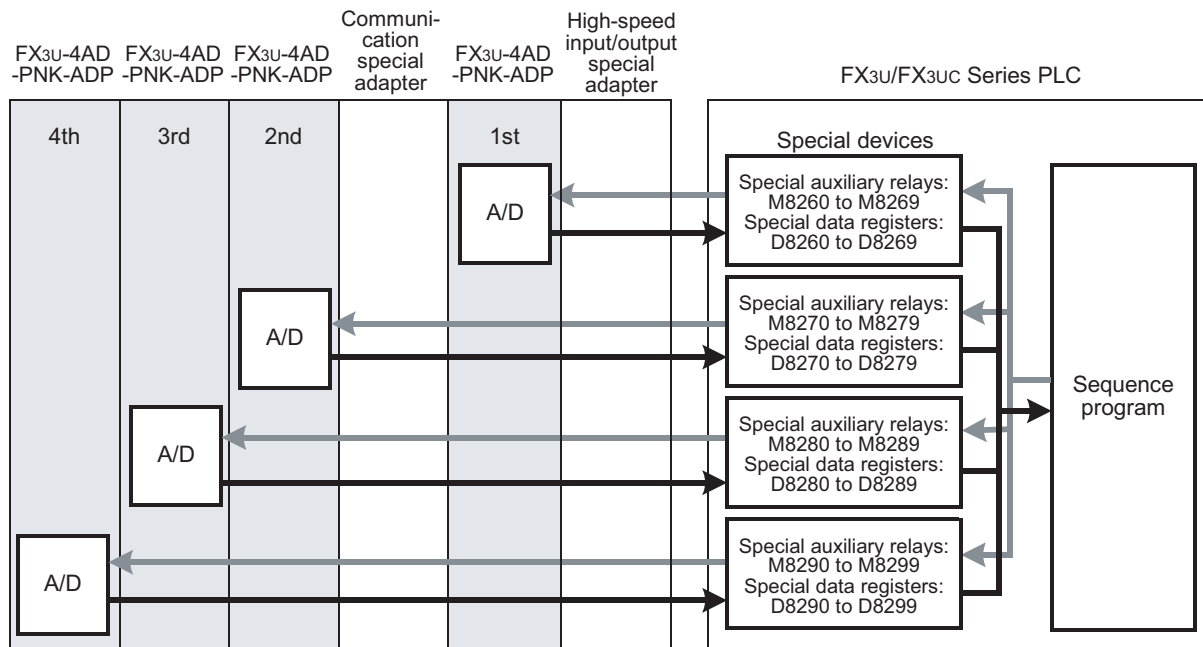

The analog special adapter nearest to the main unit is counted as the 1st analog special adapter, and the next adapter as the 2nd analog special adapter, and so on. However, in this case, do not include the high-speed input/output special adapter, communication special adapter, and the CF card special adapter.

• FX3G Series PLC

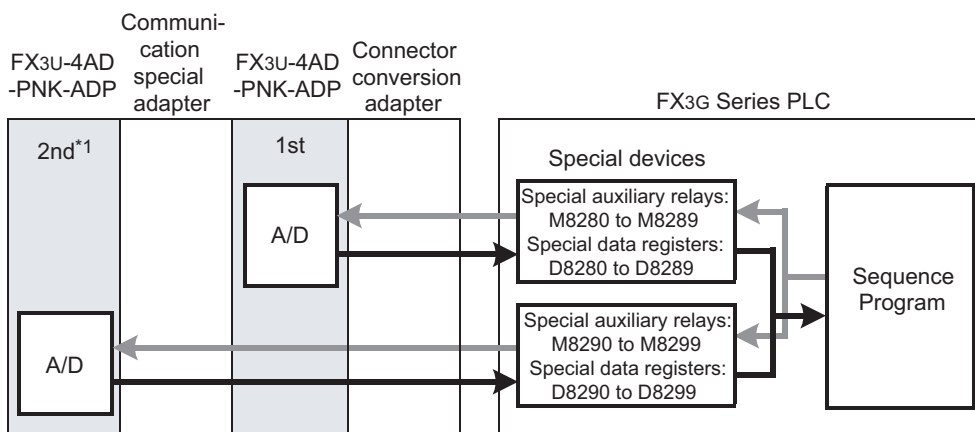

The analog special adapter nearest to the main unit is counted as the 1st analog special adapter, and the next adapter as the 2nd analog special adapter, and so on. However, in this case, do not include the connect conversion adapter and the communication special adapter.

*1. The second special adapter is not available in the FX3G Series PLC(14-point and 24-point type).

4.2 List of Special Devices

If PNK-ADP is connected, special devices will be assigned automatically as shown in the following table:

- FX3U, FX3UC Series PLC

R: Read / W: Write

Special device	Device number				Description	Attribute	Refer to
	1st	2nd	3rd	4th			
Special auxiliary relay	M8260	M8270	M8280	M8290	Selects the temperature unit	R/W	Section 4.3
	M8261	M8271	M8281	M8291	Input sensor selection	R/W	Section 4.4
	M8262 to M8269	M8272 to M8279	M8282 to M8289	M8292 to M8299	Unused (Do not use.)	-	-
Special data register	D8260	D8270	D8280	D8290	Channel-1 temperature measurement data	R	Section 4.5
	D8261	D8271	D8281	D8291	Channel-2 temperature measurement data	R	
	D8262	D8272	D8282	D8292	Channel-3 temperature measurement data	R	
	D8263	D8273	D8283	D8293	Channel-4 temperature measurement data	R	
	D8264	D8274	D8284	D8294	Averaging time for channel 1 (Setting range: 1 to 4095)	R/W	Section 4.6
	D8265	D8275	D8285	D8295	Averaging time for channel 2 (Setting range: 1 to 4095)	R/W	
	D8266	D8276	D8286	D8296	Averaging time for channel 3 (Setting range: 1 to 4095)	R/W	
	D8267	D8277	D8287	D8297	Averaging time for channel 4 (Setting range: 1 to 4095)	R/W	
	D8268	D8278	D8288	D8298	Error status	R/W	Section 4.7
	D8269	D8279	D8289	D8299	Model code = 11	R	Section 4.8

- FX3G Series PLC

R: Read / W: Write

Special device	Device number		Description	Attribute	Refer to
	1st	2nd			
Special auxiliary relay	M8280	M8290	Selects the temperature unit	R/W	Section 4.3
	M8281	M8291	Input sensor selection	R/W	Section 4.4
	M8282 to M8289	M8292 to M8299	Unused (Do not use.)	-	-
Special data register	D8280	D8290	Channel-1 temperature measurement data	R	Section 4.5
	D8281	D8291	Channel-2 temperature measurement data	R	
	D8282	D8292	Channel-3 temperature measurement data	R	
	D8283	D8293	Channel-4 temperature measurement data	R	
	D8284	D8294	Averaging time for channel 1 (Setting range: 1 to 4095)	R/W	Section 4.6
	D8285	D8295	Averaging time for channel 2 (Setting range: 1 to 4095)	R/W	
	D8286	D8296	Averaging time for channel 3 (Setting range: 1 to 4095)	R/W	
	D8287	D8297	Averaging time for channel 4 (Setting range: 1 to 4095)	R/W	
	D8288	D8298	Error status	R/W	Section 4.7
	D8289	D8299	Model code = 11	R	Section 4.8

4.3 Selection of Temperature Unit

The state of special auxiliary relays decides the PNK-ADP's temperature unit as shown in the table below. To switch the temperature unit, use the following special auxiliary relays:

- FX3U, FX3UC Series PLC

Special auxiliary relay				Description
1st	2nd	3rd	4th	
M8260	M8270	M8280	M8290	Selection of temperature unit: OFF: Centigrade (°C) ON: Fahrenheit (°F)

- FX3G Series PLC

Special auxiliary relay		Description
1st	2nd	
M8280	M8290	Selection of temperature unit: OFF: Centigrade (°C) ON: Fahrenheit (°F)

1. Program Example (For FX3U, FX3UC Series PLC)

1) To switch the temperature unit to centigrade (°C) for the 1st adapter:

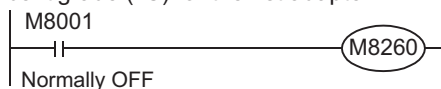

2) To switch the temperature unit to Fahrenheit (°F) for the 2nd adapter:

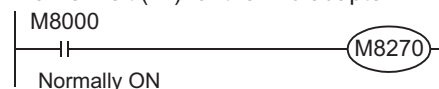

4.4 Input sensor selection

Turn on the Pt1000 type or off the Ni1000 type selection special auxiliary relay to select the Pt1000 or Ni1000 for PNK-ADP.

The input sensor type will be selected for all the channels at the same time.

To select the input sensor type, use the following special auxiliary relays:

- FX3U, FX3UC Series PLC

Special auxiliary relay				Description
1st	2nd	3rd	4th	
M8261	M8271	M8281	M8291	Input sensor selection: OFF: Pt1000 ON: Ni1000

- FX3G Series PLC

Special auxiliary relay		Description
1st	2nd	
M8281	M8291	Input sensor selection: OFF: Pt1000 ON: Ni1000

1. Program Example (For FX3U, FX3UC Series PLC)

1) To select Pt1000 for the 1st adapter:

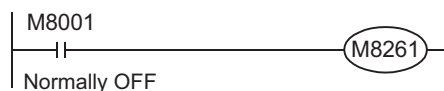

2) To select Ni1000 for the 2nd adapter :

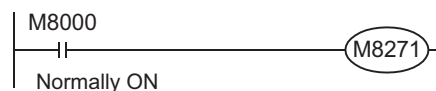

4.5 Temperature Measurement

The temperature data input in the PNK-ADP will be stored in the special data registers. The special data registers that store the temperature data are shown in the following table:

- FX3U, FX3UC Series PLC

Special data register				Description
1st	2nd	3rd	4th	
D8260	D8270	D8280	D8290	Stores the channel-1 temperature measurement data.
D8261	D8271	D8281	D8291	Stores the channel-2 temperature measurement data.
D8262	D8272	D8282	D8292	Stores the channel-3 temperature measurement data.
D8263	D8273	D8283	D8293	Stores the channel-4 temperature measurement data.

- FX3G Series PLC

Special data register		Description
1st	2nd	
D8280	D8290	Stores the channel-1 temperature measurement data.
D8281	D8291	Stores the channel-2 temperature measurement data.
D8282	D8292	Stores the channel-3 temperature measurement data.
D8283	D8293	Stores the channel-4 temperature measurement data.

The immediate data or the average data (data averaged in accordance with the specified averaging time) will be stored in the above data registers as the temperature measurement data.

→ For a detailed description of the averaging time, refer to Section 4.6.

1. Caution regarding temperature measurement

The temperature measurement data are for reading only.

Do not change (rewrite) the current data using the sequence program, indicator, or device monitor of the programming tool.

2. Program Example (For FX3U, FX3UC Series PLC)

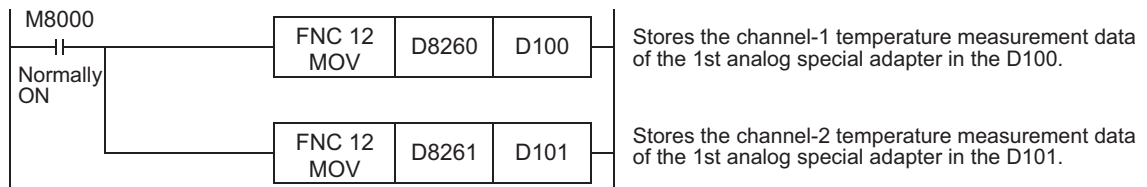

Stores the channel-1 temperature measurement data of the 1st analog special adapter in the D100.

Stores the channel-2 temperature measurement data of the 1st analog special adapter in the D101.

Even if the temperature measurement data is not stored in D100 or D101, data registers D8260 or D8261 can be directly used in the arithmetic operation instruction or a PID instruction.

4.6 Averaging Time

Setting range: 1 to 4095

Initial value: K64

Numeric data type: Decimal (K)

If the averaging time is set for the PNK-ADP, the averaged temperature measurement data will be stored in the D8260 to D8263, D8270 to D8273, D8280 to D8283, and D8290 to D8293. The averaging time can be set for each channel.

Set the averaging time in the following special data registers:

- FX3U, FX3UC Series PLC

Special data register				Description
1st	2nd	3rd	4th	
D8264	D8274	D8284	D8294	Averaging time for channel-1 data
D8265	D8275	D8285	D8295	Averaging time for channel-2 data
D8266	D8276	D8286	D8296	Averaging time for channel-3 data
D8267	D8277	D8287	D8297	Averaging time for channel-4 data

- FX3G Series PLC

Special data register		Description
1st	2nd	
D8284	D8294	Averaging time for channel-1 data
D8285	D8295	Averaging time for channel-2 data
D8286	D8296	Averaging time for channel-3 data
D8287	D8297	Averaging time for channel-4 data

1. Cautions regarding averaging time setting

- If the averaging time is set to "1", the immediate data will be stored in the temperature measurement special data register.
- If the averaging time is set to "2" or more, the average value will be calculated in accordance with the set averaging time, and the average value obtained will be stored in the temperature measurement special data register.
- After turning the PLC power on, the average data will be stored in the temperature measurement special data registers (D8260 to D8263, D8270 to D8273, D8280 to D8283, and D8290 to D8293) until the number of data items is increased to the set averaging time.
- Set the averaging time in the range from 1 to 4095. If the set value is outside the setting range, the error signal will be output.
- If the averaging time is set to "0" or smaller, the PLC will perform as if the averaging time is set to "1".
 If the averaging time is set to "4096" or larger, the PLC will perform as if the averaging time is set to "4096".
 → For a detailed description of error status, refer to Section 5.5

2. Program Example (For FX3U, FX3UC Series PLC)

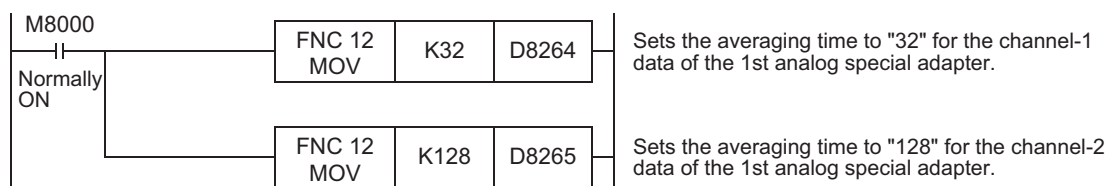

4.7 Error Status

If an error is detected on PNK-ADP, the error status data will be stored in the corresponding special data register.

The following table shows the special data registers that store the error status data:

- FX3U, FX3UC Series PLC

Special data register				Description
1st	2nd	3rd	4th	
D8268	D8278	D8288	D8298	Stores the error status data.

- FX3G Series PLC

Special data register		Description
1st	2nd	
D8288	D8298	Stores the error status data.

Check the ON/OFF status of each bit of the error status data register to determine the error. Errors are assigned to the bits as shown in the following table. Create a program to detect errors.

Bit	Description	Bit	Description
b0	The temperature measurement data of channel 1 is outside the specified range, or disconnection is detected.	b5	Averaging time setting error
b1	The temperature measurement data of channel 2 is outside the specified range, or disconnection is detected.	b6	PNK-ADP hardware error
b2	The temperature measurement data of channel 3 is outside the specified range, or disconnection is detected.	b7	PNK-ADP communication data error
b3	The temperature measurement data of channel 4 is outside the specified range, or disconnection is detected.	b8 to b15	Unused
b4	EEPROM error	-	-

1. Caution regarding use of error status data

If a PNK-ADP hardware error (b6) or PNK-ADP communication data error (b7) is once detected, it is necessary to clear the error status with a program at next power-on of the PLC.

For this reason, be sure to create the following program:

- For FX3G, FX3U, FX3UC Series PLC

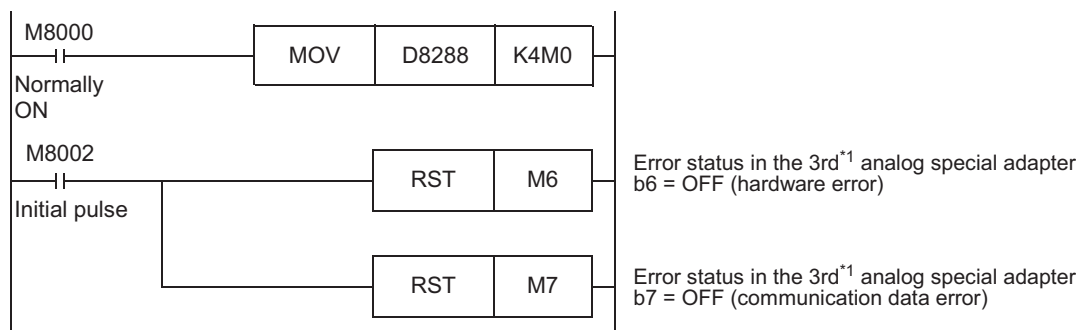

*1. "1st" for the FX3G PLC.

- For FX3U, FX3UC Series PLC

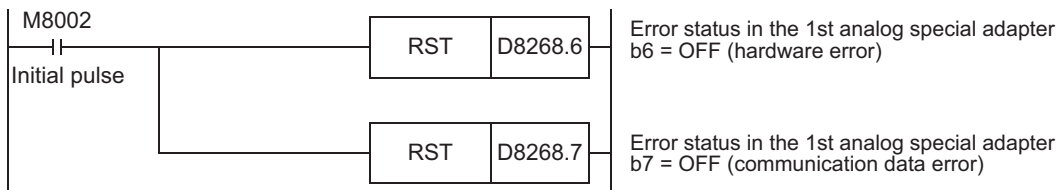

Error status in the 1st analog special adapter
 b6 = OFF (hardware error)

Error status in the 1st analog special adapter
 b7 = OFF (communication data error)

2. Program Example 1 (For FX3G, FX3U, FX3UC Series PLC)

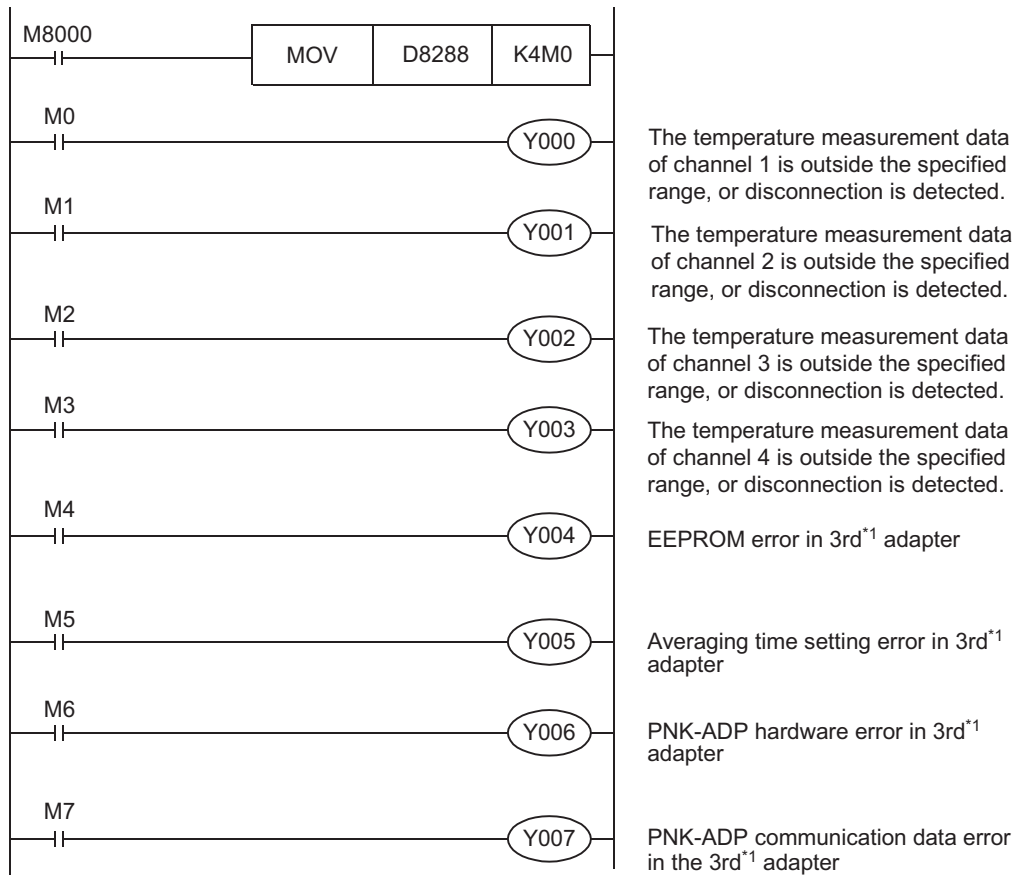

*1. "1st" for the FX3G PLC.

3. Program Example 2 (For FX3U, FX3UC Series PLC)

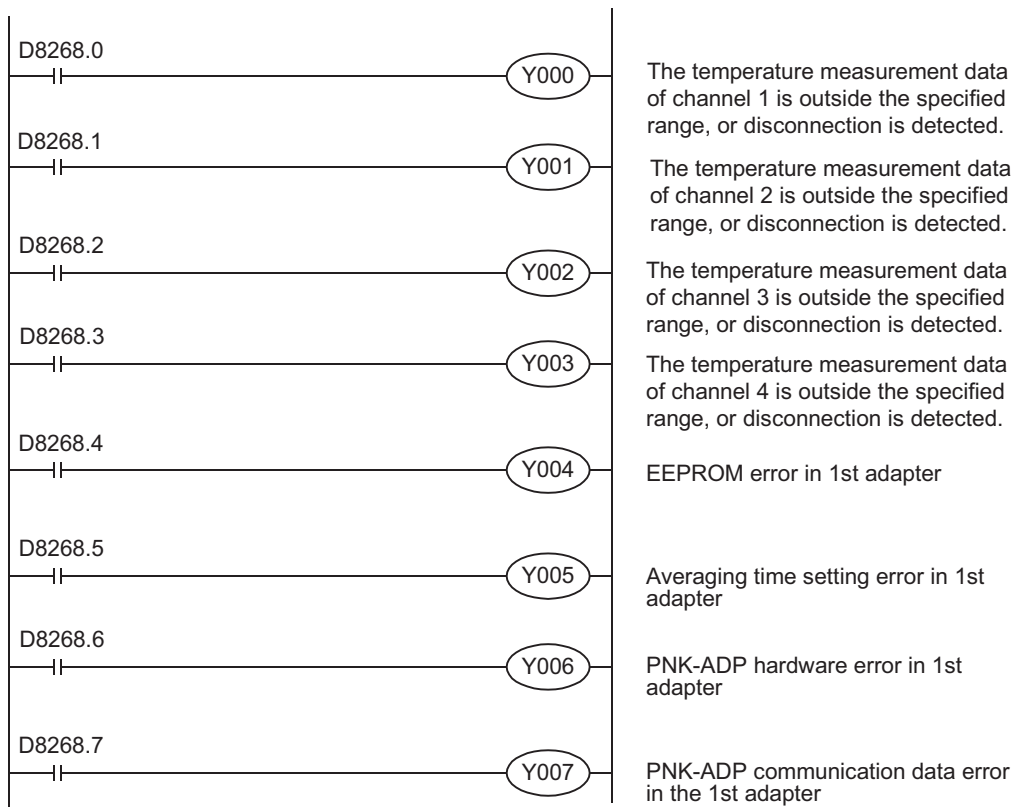

4.8 Model Code

Initial value: K11

Numeric data type: Decimal (K)

When the PNK-ADP is connected, model code "11" will be stored in the special data register.
 The following table shows the special data registers that store the model code:

- FX3U, FX3UC Series PLC

Special data register				Description
1st	2nd	3rd	4th	
D8269	D8279	D8289	D8299	Model code

- FX3G Series PLC

Special data register		Description
1st	2nd	
D8289	D8299	Model code

Use the above special data registers to check whether PNK-ADP is connected or not.

1. Program Example (For FX3U, FX3UC Series PLC)

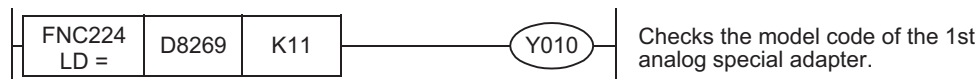

4.9 Basic Program Example

Create the following basic program to read out the temperature measurement data.

- For FX3G, FX3U, FX3UC Series PLC

The following program will select Pt1000 and will store the temperature measurement data (°C) of channels 1 and 2 of the 3rd^{*1} adapter in the D100 and the D101, respectively. The averaging time will be set to "32" for channel 1, and "128" for channel 2.

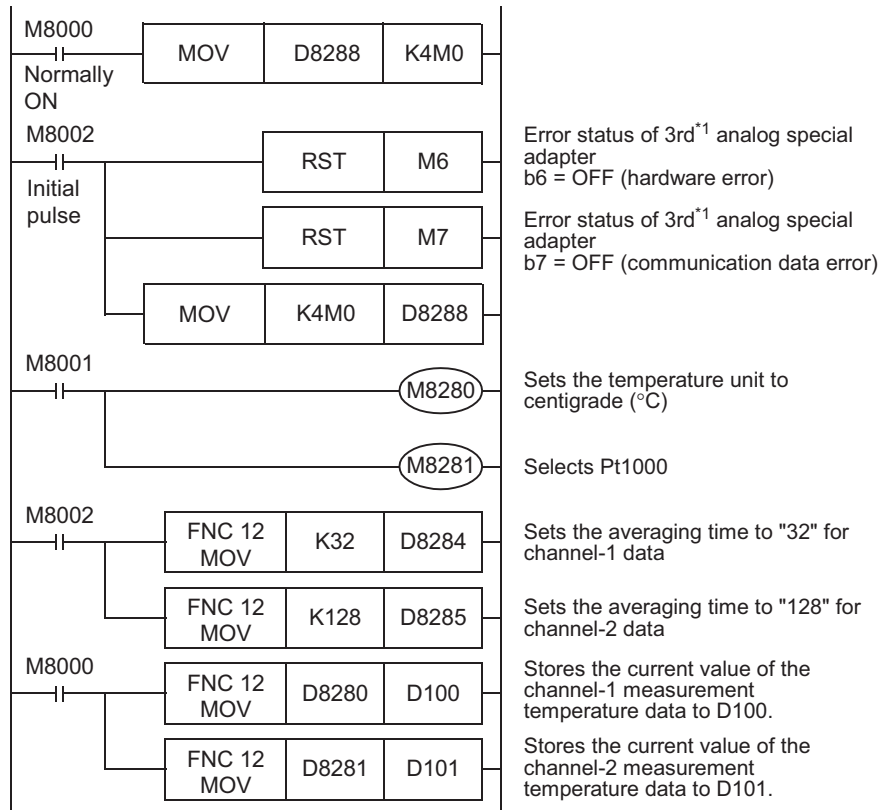

Even if the temperature measurement data is not stored to D100 or D101, data registers D8280 or D8281 can be directly used in the arithmetic operation instruction or a PID instruction.

*1. "1st" for the FX3G PLC.

- For FX3U, FX3UC Series PLC

The following program will select Pt1000 and will store the temperature measurement data (°C) of channels 1 and 2 of the 1st adapter in the D100 and the D101, respectively. The averaging time will be set to "32" for channel 1, and "128" for channel 2.

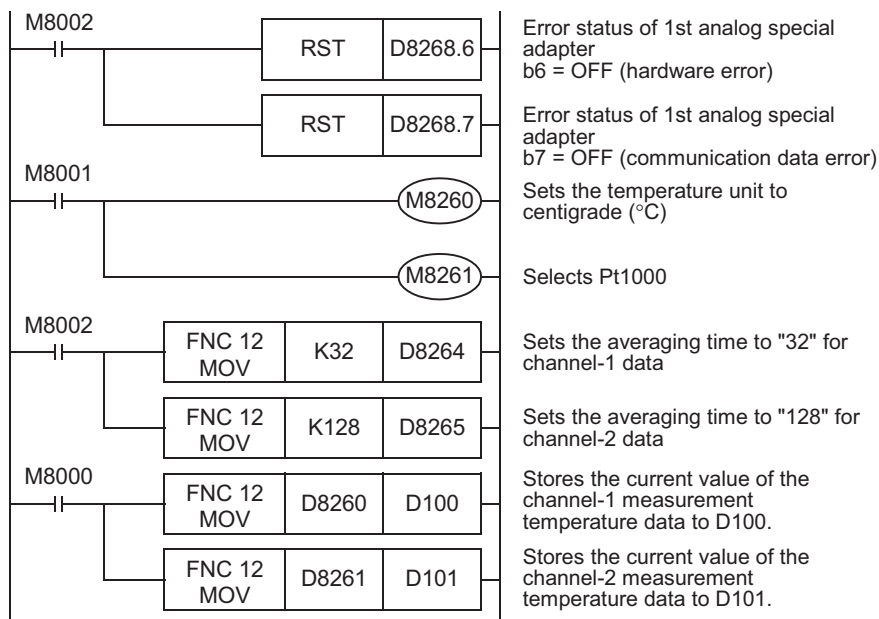

Even if the temperature measurement data is not stored to D100 or D101, data registers D8260 or D8261 can be directly used in the arithmetic operation instruction or a PID instruction.

5. Troubleshooting

This chapter describes the troubleshooting methods and error status.

If the temperature measurement data is not input, or if the proper digital value is not input, check the following items:

- Version number of the PLC
- Wiring
- Special devices
- Programs
- Error status

5.1 PLC Version Number Check

- Any versions (from Ver.2.20 (initial version) to the latest version) of the FX3U Series are compatible.
- Check the version number of FX3UC Series. The version number should be 1.30 or later.
- Any versions (from Ver.1.00 (initial version) to the latest version) of the FX3G Series are compatible.
→ **For a detailed description of the version number check method, refer to Section 1.3.**

5.2 Wiring Check

Check the following items for wiring:

1. Power

The PNK-ADP needs driving power. Verify that the power supply line is properly connected. Also check that the POWER indicator lamp of the PNK-ADP is on.

2. Resistance thermometer sensor cable

When using a 2-wire temperature sensor type, short-circuit the [L-] terminal and the [I-] terminal. Separate the cable of the resistance thermometer sensor from the other power cables or areas easily affected by inductive noise (of the commercial power, etc.).

→ **For a detailed description of wiring, refer to Chapter 3.**

5.3 Special Device Check

Check whether the special devices for the PNK-ADP are correctly used:

1. Input sensor selection

Check if the special device for type Pt1000/Ni1000 selection is correctly set. Turn off the device to select Pt1000. Turn on the device to select Ni1000.

2. Temperature measurement

Check if the special device of the selected channel is correctly set. This special device should be selected depending on the connecting position and the channel.

3. Averaging time

Verify if the set averaging time is within the specified range. The averaging time should be set in the range from 1 to 4095. If the set averaging time is outside the specified range, an error occurs.

4. Error status

Check that no error is detected in the PNK-ADP.

If an error is detected, check the details of the error, and then check the wiring and programs.

→ **For a detailed description of special devices, refer to Chapter 4.**

5.4 Program Check

Check the following items for the program:

1. Cancellation of error status at power-on

When the power is turned off and then on again, the error status should be cleared (b6 and b7 should turn off) using the program.

2. Check of storage devices

Verify that different values are not being stored in the same device by the other parts of the programs.

5.5 Error Status Check

If an error occurs in the PNK-ADP, the corresponding bit will turn on.

The bit which is turned ON due to the error status is held ON until overwritten to OFF by the program or the power is cycled. If b6 or b7 is turned ON, then it is necessary to clear the error status using the program the next time the power of the PLC is cycled.

Bit	Description	Bit	Description
b0	The temperature measurement data of channel 1 is outside the specified range, or disconnection is detected.	b5	Averaging time setting error
b1	The temperature measurement data of channel 2 is outside the specified range, or disconnection is detected.	b6	PNK-ADP hardware error
b2	The temperature measurement data of channel 3 is outside the specified range, or disconnection is detected.	b7	PNK-ADP communication data error
b3	The temperature measurement data of channel 4 is outside the specified range, or disconnection is detected.	b8	Unused
b4	EEPROM error	-	-

To solve a problem, refer to the troubleshooting method described below:

1. Temperature measurement out of specified range or disconnection of line (b0 to b3)

1) Description of error

The input temperature measurement value is outside the specified range.

The temperature measurement value of Pt1000 is not in the range between -55°C to $+256^{\circ}\text{C}$, or the temperature measurement value of Ni1000 is not in the range between -45°C to $+115^{\circ}\text{C}$.

Alternatively, wiring with Pt1000 and Ni1000 is disconnected.

2) Remedy

Check that the input temperature measurement value is within the specified range.

Also check the wiring condition.

2. EEPROM error (b4)

1) Description of error

The adjustment data set in the EEPROM before delivery from our factory is unreadable or is destroyed.

2) Remedy

Please contact the nearest Mitsubishi Electric distributor office.

3. Averaging time setting error (b5)

1) Description of error

The averaging time set for one of the channels (channels 1 to 4) is outside the specified range: 1 to 4095.

2) Remedy

Check that the averaging time is correctly set for each channel.

4. PNK-ADP hardware error (b6)

- 1) Description of error
The PNK-ADP does not operate properly.
- 2) Remedy
Check that the 24V DC power is properly supplied to the PNK-ADP.
Also check that the PNK-ADP is correctly connected to the PLC.
If the problem cannot be solved even after the above check, please contact the nearest Mitsubishi Electric distributor office.

5. PNK-ADP communication data error (b7)

- 1) Description of error
A communication error is detected between the PNK-ADP and the PLC.
- 2) Remedy
Check that the PNK-ADP is correctly connected to the PLC.
If the problem cannot be solved even after the above check, please contact the nearest Mitsubishi Electric distributor office.

MEMO

FX3G/FX3U/FX3UC Series Programmable Controllers

User's Manual [Analog Control Edition] FX3U-4AD-TC-ADP (4-channel Thermocouple Data Input)

Foreword

This manual describes the specifications, wiring, and operation methods for the FX3U-4AD-TC-ADP special adapter (4-channel thermocouple input) and should be read and understood before attempting to install or use the unit.

Store this manual in a safe place so that you can take it out and read it whenever necessary. Always forward it to the end user.

This manual confers no industrial property rights or any rights of any other kind, nor does it confer any patent licenses. Mitsubishi Electric Corporation cannot be held responsible for any problems involving industrial property rights which may occur as a result of using the contents noted in this manual.

© 2005 MITSUBISHI ELECTRIC CORPORATION

1. Outline

This chapter describes the outline of FX3U-4AD-TC-ADP (referred to as TC-ADP).

1.1 Outline of Functions

The FX3U-4AD-TC-ADP is an analog special adapter. Connect the FX3U-4AD-TC-ADP to the FX3U/FX3UC/
 FX3G Series PLC to read the data from the 4-channel thermocouple.

- 1) Up to 4 TC-ADP units can be connected to the FX3U/FX3UC Series PLC.
 Up to 2*1 TC-ADP units can be connected to the FX3G Series PLC.
 (Including other analog special adapters)
- 2) Thermocouple types K and J can be connected. (However, it's impossible to use both types K and J with 1 adapter.)
- 3) A/D conversion data will be automatically written to the special data register of the FX3U/FX3UC/FX3G Series PLC.

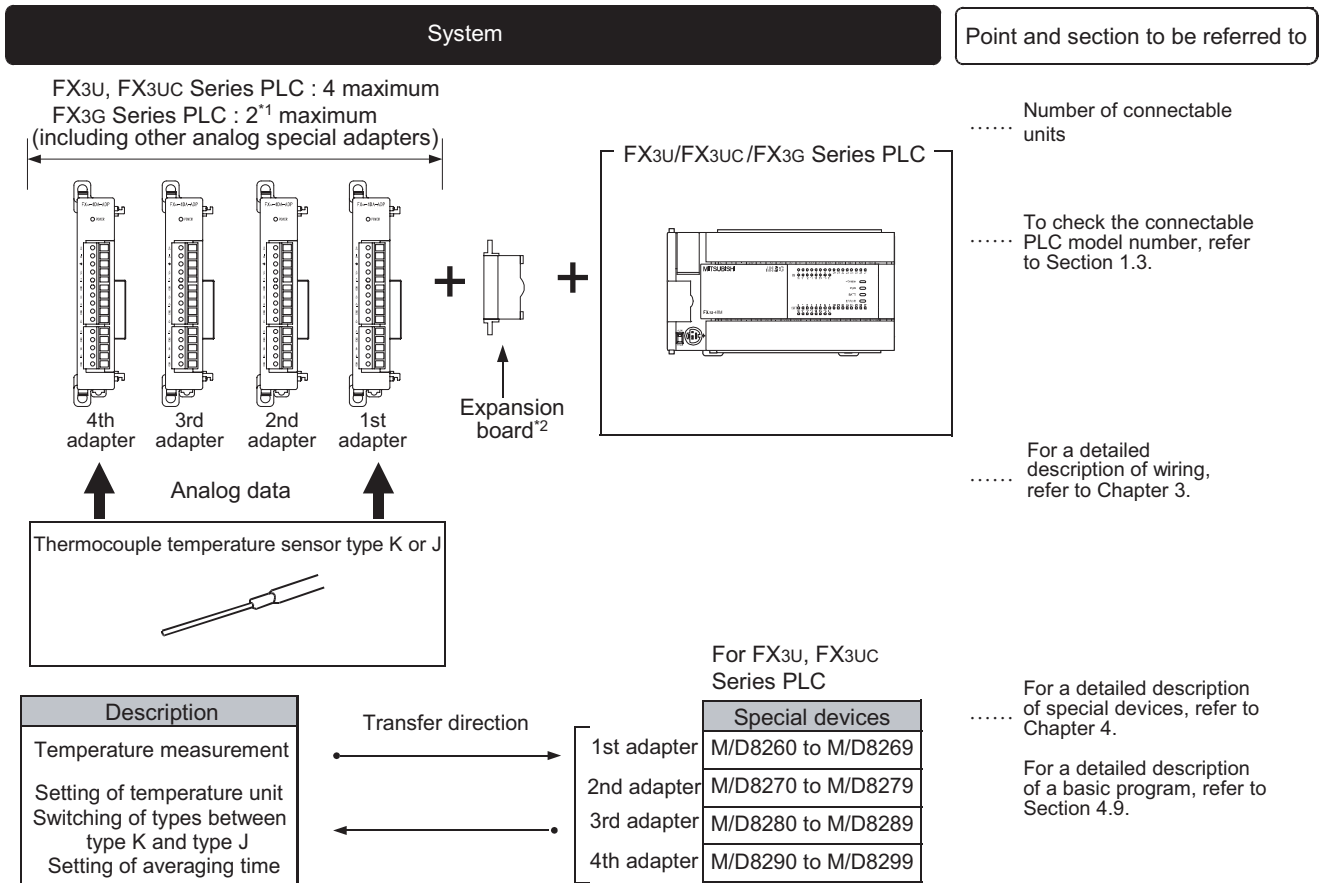

Refer to the system configuration shown in the User's Manual - Hardware Edition to check the number of connectable units and to configure the entire system.

*1. Only 1 analog special adapter can be connected to the 14-point and 24-point type main unit.

*2. The expansion board is not required when connecting with the FX3UC (D, DSS) PLC.
 For the FX3G Series PLC a connector conversion adapter is used.

1.2 Setup Procedure Before Starting Operation

Before starting analog input using TC-ADP, follow the procedure below to set up the system:

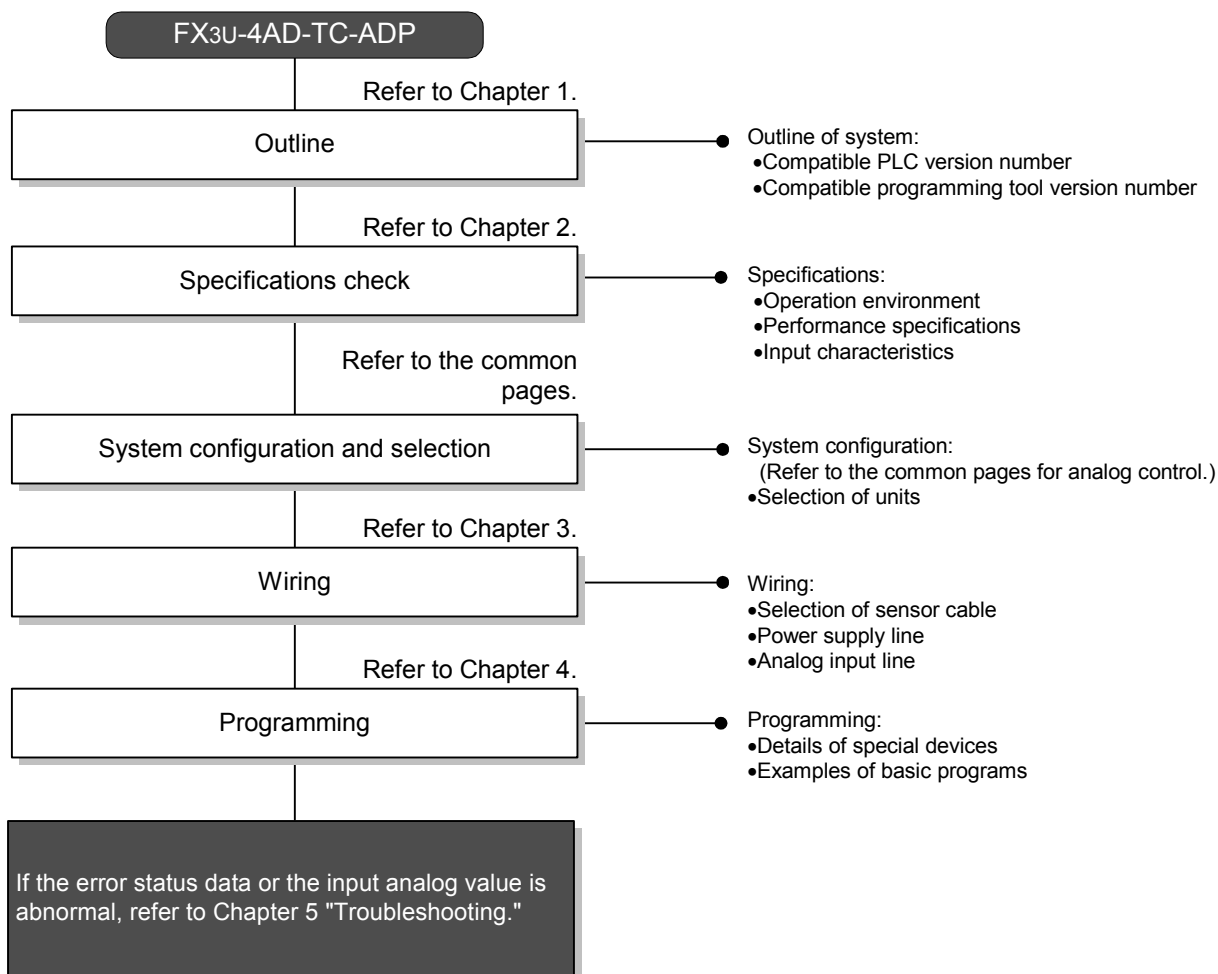

1.3 Connectable PLC and Its Version Number

TC-ADP is compatible with the following PLC.

Compatible PLC	Version number	Date of production
FX3U Series PLC	Ver. 2.20 or later	After May 2005 (initial production)
FX3UC Series PLC	Ver. 1.30 or later	After August 2004
FX3G Series PLC	Ver. 1.00 or later	After June 2008 (initial production)

1. Version check

Special data register D8001 contains information for determining the PLC version number.

→ For a detailed description of the version check, refer to A. Common Items Subsection 5.1.2.

2. How to check the manufacturer's serial number

The year and month of production of the product can be checked on the nameplate, and on the front of the product.

→ For a detailed description of how to check the manufacturer's serial number, refer to A. Common Items Subsection 5.1.1.

1.4 Compatible Programming Tool Version Number

Use the programming tool having the following version number to create programs for TC-ADP:

1. GX Works2

Software	Version number	Remarks
GX Works2 SW□DNC-GXW2-J	Ver. 1.07H or later	-
GX Works2 SW□DNC-GXW2-E	Ver. 1.08J or later	-

2. GX Developer

- FX3U/FX3UC Series PLC

Software	Version number	Remarks
GX Developer SW□D5C-GPPW-J	Ver. 8.13P or later	When selecting the model, select FX3U(C) ^{*1} .
GX Developer SW□D5C-GPPW-E	Ver. 8.18U or later	

- FX3G Series PLC

Software	Version number	Remarks
GX Developer • SW□D5C-GPPW-J • SW□D5C-GPPW-E	Ver. 8.72A or later	-

If a programming tool with the wrong version number is used, programming will not be possible.

*1. For Ver. 8.13P to 8.24A of GX Developer, select FX3UC for the PLC type.

3. FX-30P

Model name	Version number	Remarks
FX-30P	Ver. 1.00 or later	-

2. Specifications

This chapter describes the general, power supply, and performance specifications for the TC-ADP.

2.1 Generic Specifications

Item	Specifications				
Ambient temperature	0 to 55°C (32 to 131°F) when operating -25 to 75°C (-13 to 167°F) when stored				
Relative humidity	5 to 95%RH (no condensation) when operating				
Vibration resistance *1	DIN Rail Mounting	Frequency (Hz)	Acceleration (m/s ²)	Half amplitude (mm)	Tested 10 times in each direction (X-, Y-, and Z-axis directions) (Total: 80 min, each)
		10 - 57	-	0.035	
	Direct Mounting *2	57 - 150	4.9	-	
		10 to 57	-	0.075	
Shock resistance *1	147 m/s ² Acceleration, Action time: 11ms, 3 times by half-sine pulse in each direction X, Y, and Z				
Noise resistance	Using noise simulator of: Noise voltage: 1,000Vp-p / Noise width: 1μs / Rise: 1ns / Cycle: 30 to 100Hz				
Dielectric withstand voltage	500 V AC, for 1 min		Between batch of all terminals and ground terminal		
Insulation resistance	5MΩ or more using 500V DC insulation resistance meter				
Grounding	Class D grounding (grounding resistance: 100 Ω or less) <Common grounding with a heavy electrical system is not allowed.>*3				
Working environment	Free from corrosive or flammable gas and excessive conductive dusts				
Working altitude	< 2000m*4				

*1. The criterion is shown in IEC61131-2.

*2. If TC-ADP is connected to the FX3UC Series PLC, direct installation is not possible.

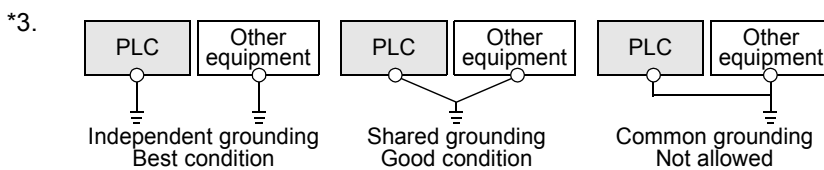

→ For a detailed description of the grounding, refer to Section 3.7.

*4. If the pressure is higher than the atmospheric pressure, do not use the TC-ADP.
 The TC-ADP may malfunction.

2.2 Power Supply Specifications

Item	Specifications
A/D conversion circuit driving power	24V DC +20% -15%, 45mA (It is necessary to connect a 24V DC power supply to the terminal block.)
Interface driving power	5V DC, 15mA (Since the internal power is supplied from the FX Series main unit, it is not necessary to supply the power.)

2.3 Performance Specifications

Item	Specifications			
	Centigrade (°C)		Fahrenheit (°F)	
Input signal	Thermocouple type K or J JIS C 1602-1995			
Rated temperature range	Type K	-100°C to +1000°C	Type K	-148°F to +1832°F
	Type J	-100°C to +600°C	Type J	-148°F to +1112°F
Digital output	Type K	-1000 to +10000	Type K	-1480 to +18320
	Type J	-1000 to +6000	Type J	-1480 to +11120
Resolution	Type K	0.4°C	Type K	0.72°F
	Type J	0.3°C	Type J	0.54°F
Total accuracy	±(0.5% full scale +1°C)			
A/D conversion time	<ul style="list-style-type: none"> FX3U/FX3UC Series PLC : 200μs (The data will be updated at every scan time.) FX3G Series PLC : 250μs (The data will be updated at every scan time.) →For a detailed description of data update, refer to Section2.4.			
Input characteristics				
Insulation method	<ul style="list-style-type: none"> The photocoupler is used to insulate the analog input area from the PLC. The DC/DC converter is used to insulate the power supply line from the analog input area. Channels are not insulated from each other. 			
Number of I/O points occupied	0 points (This number is not related to the maximum number of input/output points of the PLC.)			

K
FX3U-4AD-PNK-ADP
L
FX3U-4AD-TC-ADP
M
PID Instruction (FNC 88)

2.4 A/D Conversion Time

This section describes the A/D conversion time.

2.4.1 When connected to a FX3U, FX3UC PLC

1. A/D conversion and special data register update timing

A/D conversion is performed at every scan time of the PLC.

During execution of END instruction, the PLC performs A/D conversion, reads out the A/D converted data, and then writes the data in the special data registers.

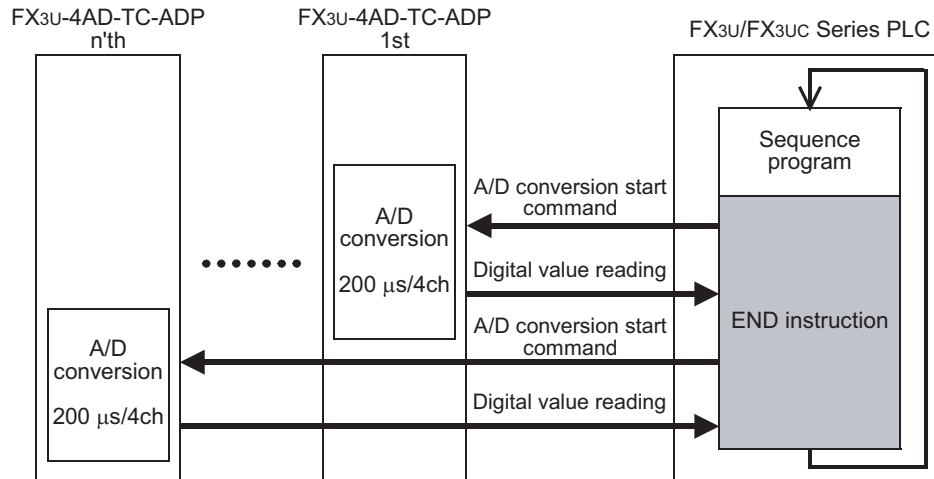

2. A/D conversion during PLC stop

Even if the PLC is stopped, A/D conversion will be performed and the special data registers will be updated.

3. If two or more analog special adapters are connected

During execution of the END instruction, data will be read out from all the connected adapters (in the order of 1st adapter → 2nd adapter...4th adapter).

4. A/D conversion speed (data update time)

During execution of the END instruction, the A/D converted data of all 4 channels will be read out in 200μs, and the data read out will be written to the special data registers.

END instruction execution time will be "200μs × number of connected adapters."

2.4.2 When connected to a FX3G PLC

1. A/D conversion and special data register update timing

A/D conversion is performed at every scan time of the PLC.

During execution of END instruction, the PLC performs A/D conversion, reads out the A/D converted data, and then writes the data in the special data registers.

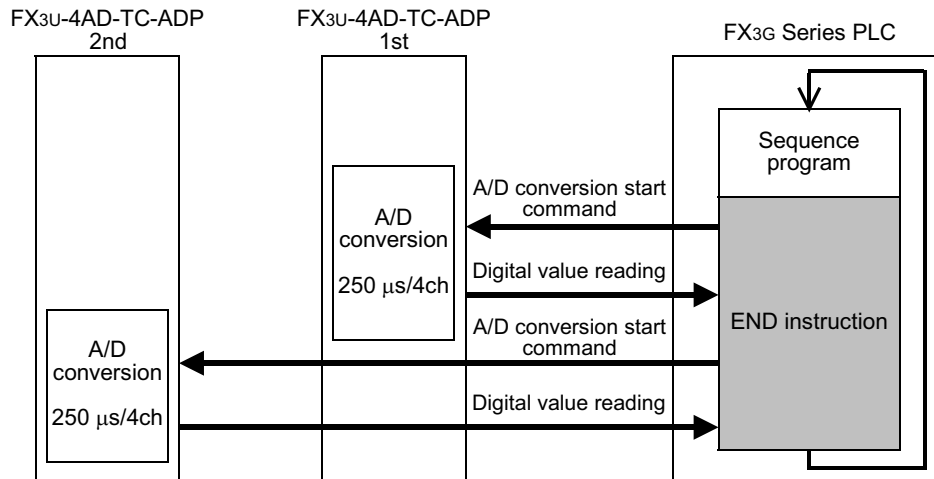

2. A/D conversion during PLC stop

Even if the PLC is stopped, A/D conversion will be performed and the special data registers will be updated.

3. If two analog special adapters are connected

During execution of the END instruction, data will be read out from all the connected adapters (in the order of 1st adapter → 2nd adapter).

4. A/D conversion speed (data update time)

During execution of the END instruction, the A/D converted data of all 4 channels will be read out in 250μs, and the data read out will be written to the special data registers.

END instruction execution time will be "250μs × number of connected adapters."

2.5 Temperature Measurement

To stabilize the temperature measurement, warm-up the system for 30 minutes or more after power-on.

3. Wiring

This chapter describes the TC-ADP wiring.
Observe the following caution to wire the TC-ADP.

WIRING PRECAUTIONS



DANGER

- Make sure to cut off all phases of the power supply externally before attempting wiring work. Failure to do so may cause electric shock or damages to the product.

WIRING PRECAUTIONS



CAUTION

- Connect the DC power supply wiring to the dedicated terminals described in this manual. If an AC power supply is connected to a DC input/output terminal or DC power supply terminal, the PLC will be burnt out.
- Do not wire vacant terminals externally. Doing so may damage the product.
- Perform class D grounding (grounding resistance: 100Ω or less) to the grounding terminal on the main unit. Do not use common grounding with heavy electrical systems.
- When drilling screw holes or wiring, make sure cutting or wire debris does not enter the ventilation slits. Failure to do so may cause fire, equipment failures or malfunctions.
- Make sure to observe the following precautions in order to prevent malfunctions under the influence of noise:
 - Do not bundle the power line or twisted shielded cable together with or lay it close to the main circuit, high-voltage line, or load line. Otherwise, noise disturbance and/or surge induction are likely to take place. As a guideline, lay the control line at least 100mm (3.94") or more away from the main circuit, high-voltage line, or load line.
 - Ground the shield of the analog input/output cable at one point on the signal receiving side. However, do not use common grounding with heavy electrical systems.
- Make sure to properly wire to the European terminal board in accordance with the following precautions. Failure to do so may cause electric shock, equipment failures, a short-circuit, wire breakage, malfunctions, or damage to the product.
 - The disposal size of the cable end should follow the dimensions described in the manual.
 - Tightening torque should follow the specifications in the manual.
 - Twist the end of strand wire and make sure there are no loose wires.
 - Do not solder-plate the electric wire ends.
 - Do not connect more than the specified number of wires or electric wires of unspecified size.
 - Affix the electric wires so that neither the terminal block nor the connected parts are directly stressed.

3.1 Terminal Layout

The terminals of the TC-ADP are arranged as follows:

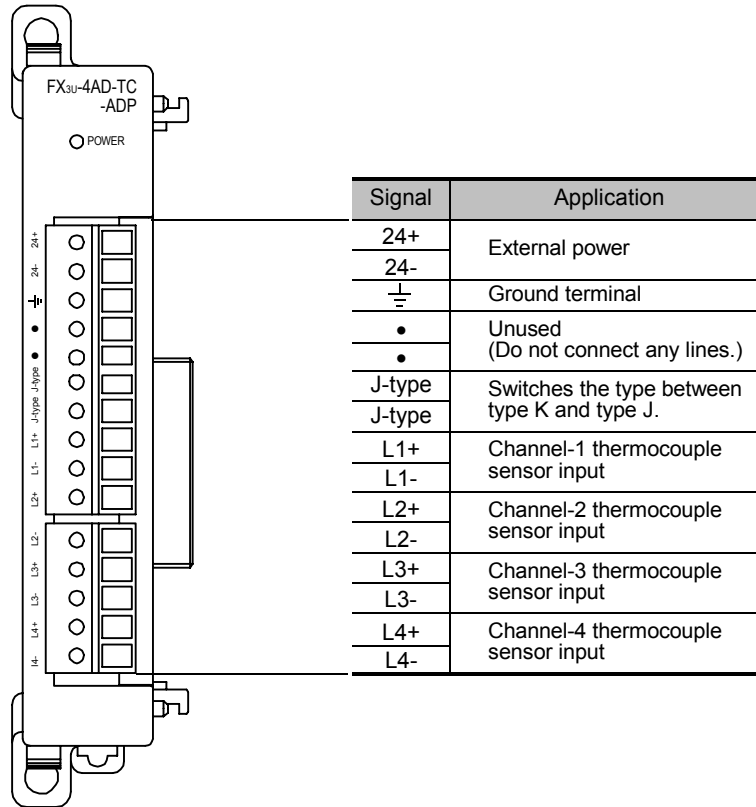

3.2 Applicable Cables and Terminal Tightening Torque

Use the following cables to connect with the counterpart equipment. Terminate the cable end as shown below.

1. Cables

Applicable cable and tightening torque

	Wire size (stranded/single-wire)	Tightening torque	Termination
Single-wire	0.3 mm ² to 0.5 mm ² (AWG22 to 20)	0.22 N•m to 0.25 N•m	<ul style="list-style-type: none"> To connect a stranded cable, peel the cover off the cable and then twist the core before connection. To connect a single-wire cable, just strip the cover off the cable before connection. Rod terminal with insulation sleeve (recommended terminal) AI 0.5-8WH : Manufactured by Phoenix Contact Caulking tool CRIMPFOX 6*1 : Manufactured by Phoenix Contact (or CRIMPFOX 6T-F*2 : Manufactured by Phoenix Contact)
2-wire	0.3mm ² (AWG22)		
Rod terminal with insulation sleeve	0.3 mm ² to 0.5 mm ² (AWG22-20) (Refer to the rod terminal external view shown in the following figure.)		

- *1. Old model name : CRIMPFOX ZA 3
- *2. Old model name : CRIMPFOX UD 6

2. Termination of cable end

To terminate the cable, treat the stranded/single wire directly or use a rod terminal with insulation sleeve.

- To directly terminate the end of a stranded/single-wire cable:
 - Twist the end of the stranded cable so that the "barbed wires" cannot protrude.
 - Do not solder-plate the end of the cable.

Termination of cable end

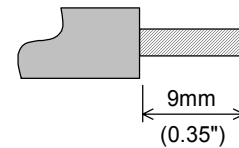

- To terminate cable end using a rod terminal with insulation sleeve:
 If the cable cover is too thick, it may be difficult to insert the cable into the insulation sleeve. For this reason, select an appropriate cable while referring to the external view.

<Reference>

Manufacturer	Model	Caulking tool
Phoenix Contact	AI 0.5-8WH	CRIMPFOX 6*3 (or CRIMPFOX 6T-F*4)

- *3. Old model name : CRIMPFOX ZA 3
- *4. Old model name : CRIMPFOX UD 6

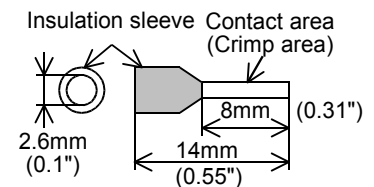

3. Tool

- To tighten terminals, use a small-sized screwdriver whose head is straight and is not widened as shown in the figure to the right.

Note:

If the diameter of screwdriver grip is too small, tightening torque will not be able to be achieved. To achieve the appropriate tightening torque shown in the table above, use the following screwdriver or an appropriate replacement (grip diameter: approximately 25mm (0.98")).

<Reference>

Manufacturer	Model
Phoenix Contact	SZS 0.4×2.5

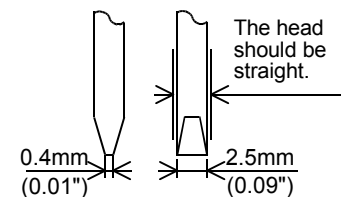

3.3 Power Supply Line

Connect the 24V DC power supply line of the TC-ADP to the 24+ and 24- terminals of the terminal block.

3.3.1 To connect to the FX3G, FX3U Series PLC

1. To use an external power

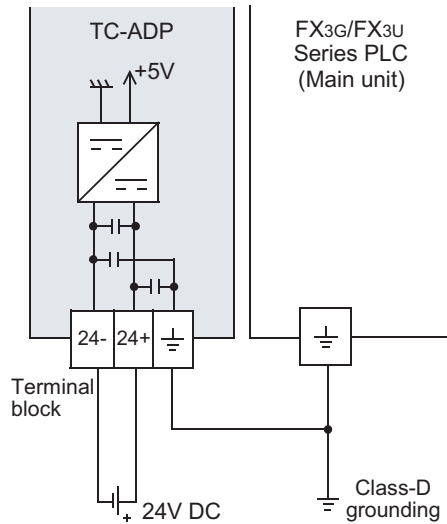

2. To use the 24V DC power of the PLC

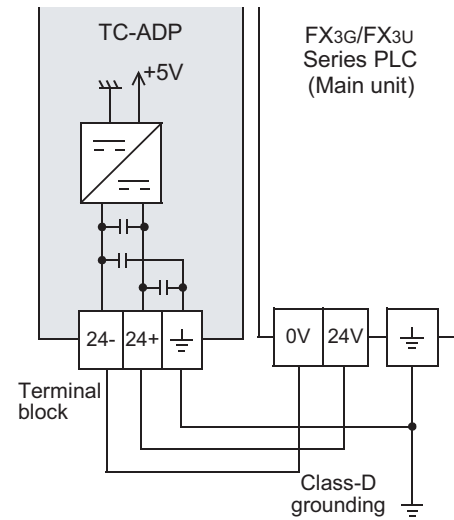

Caution regarding connection of the power supply line:

- Ground the "⊥" terminal to a class-D grounding power supply line (100Ω or less) together with the grounding terminal of the PLC main unit.
- When using an external power supply, turn it ON at the same time with the main unit or earlier than the main unit. When turning OFF the power, confirm the safety of the system, and then turn OFF the power of the PLC (including special adapter) at the same time.

3.3.2 To connect to the FX3UC Series PLC

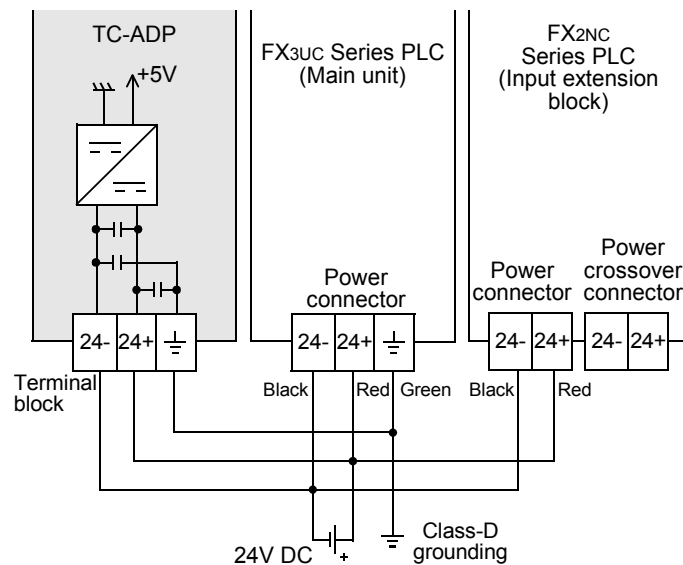

Cautions regarding connection of the power supply line:

- For the 24V DC power supply line, be sure to use the same power as the FX3UC Series PLC.
- Ground the "⊥" terminal to a class-D grounding power supply line (100Ω or less) together with the ground terminal of the PLC main unit.

3.4 Selection of the Thermocouple

3.4.1 Thermocouple type

- There are 2 types of thermocouples: K type and J type. When selecting the thermocouple type, make sure that the same type of thermocouple is connection to all the channels.
- Be sure to use a non-grounded thermocouple type.

3.4.2 Compensating lead wire

To connect the thermocouple, use one of the following types of compensating lead wires:

Thermocouple	Type of compensating lead wire
Type K	KX,KCA,KCB,KCC
Type J	JX

- The compensating lead wire indicates a temperature value of approximately 0.12°C higher than that of the wire resistor (10Ω). Use the appropriate compensating lead wire when considering this difference.
- If the compensating lead wire is very long, the wire may be easily affected by noise, etc. It is, therefore, recommended for the length of the compensating lead wire to be 100 m or less.

3.5 Wiring of Thermocouple

Wiring depends on the thermocouple type selected. Refer to the following wiring diagrams:

3.5.1 Wiring of thermocouple type K

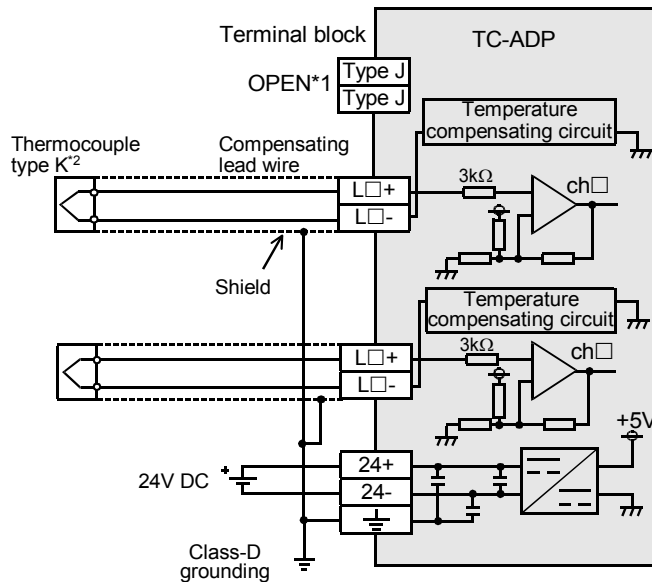

L□+, L□-, ch□: □ represents the channel number.

- *1. It is not necessary to connect lines to the J-type terminals. Leave these terminals disconnected.
- *2. Keep the thermocouple away from inductive noise (commercial power, etc.).

3.5.2 Wiring of the thermocouple type J

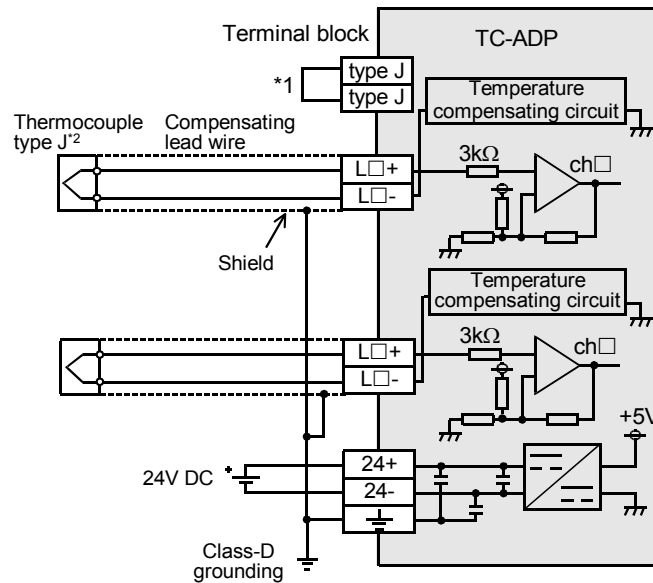

L□+, L□-, ch□: □ represents the channel number.

- *1. To use a J thermocouple type, be sure to connect the thermocouple to these terminals. In addition, select J type by turning on the type K/J selection special auxiliary relay.
- *2. Keep the thermocouple away from inductive noise (commercial power, etc.).

3.6 Caution Regarding Wiring

- It is not possible to connect different types of thermocouples to 4 channels of TC-ADP. Be sure to use the same type of thermocouple for all the channels.
- TC-ADP is not insulated between the channels. For this reason, be sure to use a non-grounded type thermocouple.
- Be sure not to connect to the terminal "•".

3.7 Grounding

Grounding should be performed as stated below.

- The grounding resistance should be 100Ω or less.
- Independent grounding should be performed for best results. When independent grounding is not performed, perform "shared grounding" as shown in the following figure.

→ For details, refer to the User's Manual - Hardware Edition of the PLC Series.

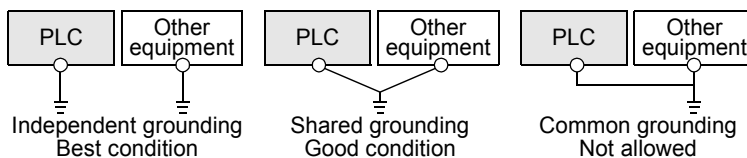

- The grounding wire size should be AWG22 to 20 (0.3 to 0.5 mm²).
- The grounding point should be close to the PLC, and all grounding wires should be as short as possible.

4. Programming

This chapter describes how to create programs that can read out the analog data using the TC-ADP.

4.1 Loading of A/D Conversion Data

- 1) The input analog data will be converted into digital data and then stored in the special devices of the FX3U/FX3UC/FX3G Series PLC.
 - 2) If data is stored in the special devices, the averaging time can be set, and the input mode can be specified.
 - 3) Special auxiliary relays (10 points) and special data registers (10 points) are assigned automatically starting from the adapter nearest to the main unit.
 → For a detailed description of special device assignment, refer to Subsection 4.2.
- FX3U, FX3UC Series PLC

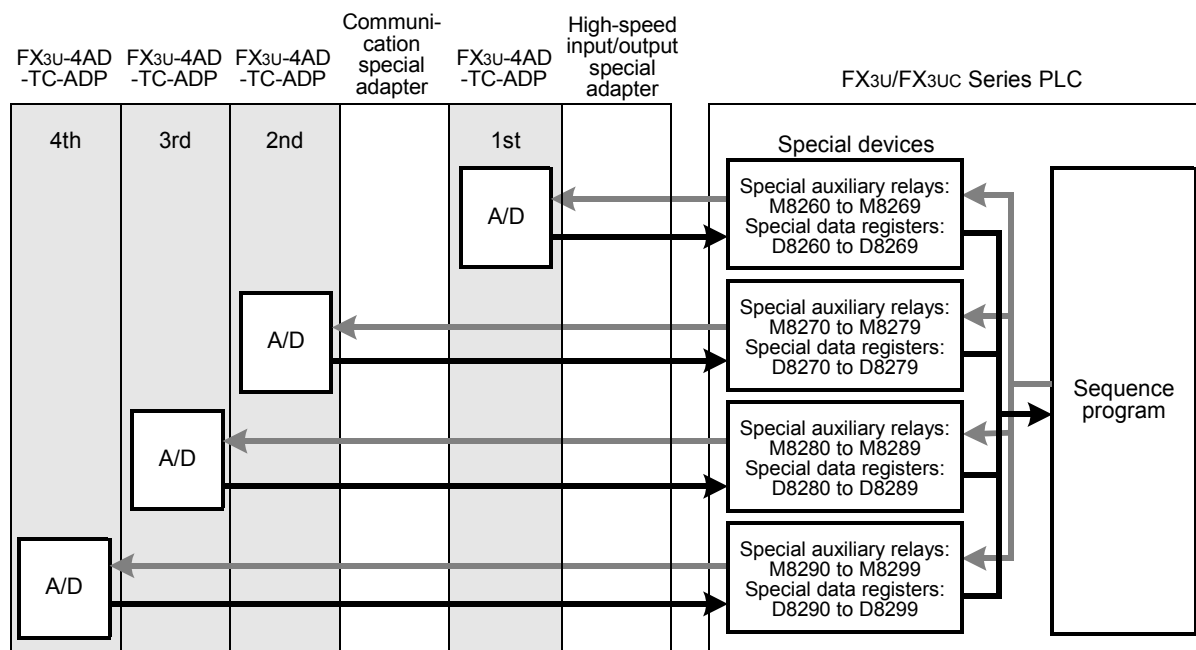

The analog special adapter nearest to the main unit is counted as the 1st analog special adapter, and the next adapter as the 2nd analog special adapter, and so on. However, in this case, do not include the high-speed input/output special adapter, communication special adapter, and the CF card special adapter.

• FX3G Series PLC

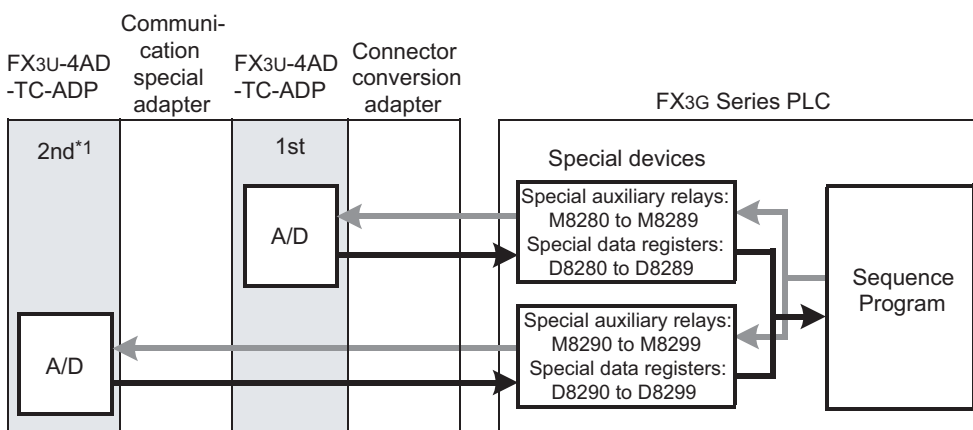

The analog special adapter nearest to the main unit is counted as the 1st analog special adapter, and the next adapter as the 2nd analog special adapter. However, in this case, do not include the connector conversion adapter and the communication special adapter.

*1. The second special adapter is not available in the FX3G Series PLC(14-point and 24-point type).

K
 FX3U-4AD-FNK-ADP
 L
 FX3U-4AD-TC-ADP
 M
 PID Instruction (FNC 88)

4.2 List of Special Devices

If TC-ADP is connected, special devices will be assigned automatically as shown in the following table:

- FX3U, FX3UC Series PLC

R: Read / W: Write

Special device	Device number				Description	Attribute	Refer to
	1st	2nd	3rd	4th			
Special auxiliary relay	M8260	M8270	M8280	M8290	Selects the temperature unit	R/W	Section 4.3
	M8261	M8271	M8281	M8291	Switches the thermocouple type between type K and type J	R/W	Section 4.4
	M8262 to M8269	M8272 to M8279	M8282 to M8289	M8292 to M8299	Unused (Do not use.)	-	-
Special data register	D8260	D8270	D8280	D8290	Channel-1 temperature measurement data	R	Section 4.5
	D8261	D8271	D8281	D8291	Channel-2 temperature measurement data	R	
	D8262	D8272	D8282	D8292	Channel-3 temperature measurement data	R	
	D8263	D8273	D8283	D8293	Channel-4 temperature measurement data	R	
	D8264	D8274	D8284	D8294	Averaging time for channel 1 (Setting range: 1 to 4095)	R/W	Section 4.6
	D8265	D8275	D8285	D8295	Averaging time for channel 2 (Setting range: 1 to 4095)	R/W	
	D8266	D8276	D8286	D8296	Averaging time for channel 3 (Setting range: 1 to 4095)	R/W	
	D8267	D8277	D8287	D8297	Averaging time for channel 4 (Setting range: 1 to 4095)	R/W	
	D8268	D8278	D8288	D8298	Error status	R/W	Section 4.7
D8269	D8279	D8289	D8299	Model code = 10	R	Section 4.8	

- FX3G Series PLC

R: Read / W: Write

Special device	Device number		Description	Attribute	Refer to
	1st	2nd			
Special auxiliary relay	M8280	M8290	Selects the temperature unit	R/W	Section 4.3
	M8281	M8291	Switches the thermocouple type between type K and type J	R/W	Section 4.4
	M8282 to M8289	M8292 to M8299	Unused (Do not use.)	-	-
Special data register	D8280	D8290	Channel-1 temperature measurement data	R	Section 4.5
	D8281	D8291	Channel-2 temperature measurement data	R	
	D8282	D8292	Channel-3 temperature measurement data	R	
	D8283	D8293	Channel-4 temperature measurement data	R	
	D8284	D8294	Averaging time for channel 1 (Setting range: 1 to 4095)	R/W	Section 4.6
	D8285	D8295	Averaging time for channel 2 (Setting range: 1 to 4095)	R/W	
	D8286	D8296	Averaging time for channel 3 (Setting range: 1 to 4095)	R/W	
	D8287	D8297	Averaging time for channel 4 (Setting range: 1 to 4095)	R/W	
	D8288	D8298	Error status	R/W	Section 4.7
	D8289	D8299	Model code = 10	R	Section 4.8

4.3 Selection of Temperature Unit

The state of special auxiliary relays decides the TC-ADP's temperature unit as shown in the table below. To switch the temperature unit, use the following special auxiliary relays:

- FX3U, FX3UC Series PLC

Special auxiliary relay				Description
1st	2nd	3rd	4th	
M8260	M8270	M8280	M8290	Selection of temperature unit: OFF: Centigrade (°C) ON: Fahrenheit (°F)

- FX3G Series PLC

Special auxiliary relay		Description
1st	2nd	
M8280	M8290	Selection of temperature unit: OFF: Centigrade (°C) ON: Fahrenheit (°F)

1. Program Example (For FX3U, FX3UC Series PLC)

1) To switch the temperature unit to centigrade (°C) for the 1st adapter:

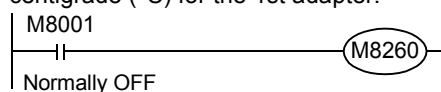

2) To switch the temperature unit to Fahrenheit (°F) for the 2nd adapter:

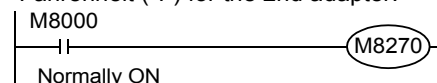

4.4 Selection of Type K or J

Turn on the J type or off the K type selection special auxiliary relay to select the thermocouple type J or K for TC-ADP.

The thermocouple type will be selected for all the channels at the same time.

To select the thermocouple type, use the following special auxiliary relays:

- FX3U, FX3UC Series PLC

Special auxiliary relay				Description
1st	2nd	3rd	4th	
M8261	M8271	M8281	M8291	Selection of type K or J: OFF: Type K ON: Type J

- FX3G Series PLC

Special auxiliary relay		Description
1st	2nd	
M8281	M8291	Selection of type K or J: OFF: Type K ON: Type J

1. Program Example (For FX3U, FX3UC Series PLC)

1) To select thermocouple type K for the 1st adapter:

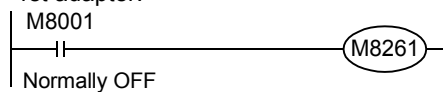

2) To select thermocouple type J for the 2nd adapter :

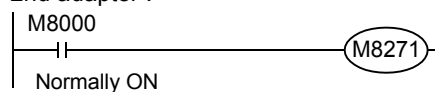

4.5 Temperature Measurement

The temperature data input in the TC-ADP will be stored in the special data registers. The special data registers that store the temperature data are shown in the following table:

- FX3U, FX3UC Series PLC

Special data register				Description
1st	2nd	3rd	4th	
D8260	D8270	D8280	D8290	Stores the channel-1 temperature measurement data.
D8261	D8271	D8281	D8291	Stores the channel-2 temperature measurement data.
D8262	D8272	D8282	D8292	Stores the channel-3 temperature measurement data.
D8263	D8273	D8283	D8293	Stores the channel-4 temperature measurement data.

- FX3G Series PLC

Special data register		Description
1st	2nd	
D8280	D8290	Stores the channel-1 temperature measurement data.
D8281	D8291	Stores the channel-2 temperature measurement data.
D8282	D8292	Stores the channel-3 temperature measurement data.
D8283	D8293	Stores the channel-4 temperature measurement data.

The immediate data or the average data (data averaged in accordance with the specified averaging time) will be stored in the above data registers as the temperature measurement data.

→ For a detailed description of the averaging time, refer to Section 4.6.

1. Caution regarding temperature measurement

The temperature measurement data are for reading only.

Do not change (rewrite) the current data using the sequence program, indicator, or device monitor of the programming tool.

2. Program Example (For FX3U, FX3UC Series PLC)

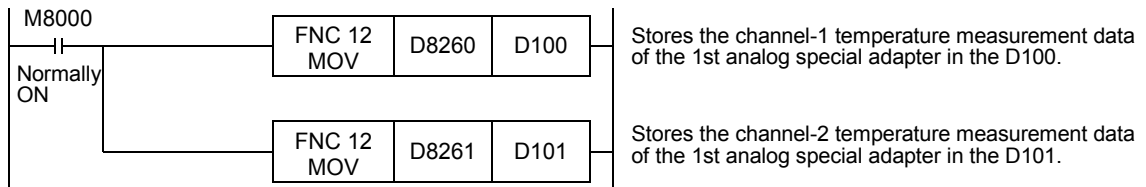

Stores the channel-1 temperature measurement data of the 1st analog special adapter in the D100.

Stores the channel-2 temperature measurement data of the 1st analog special adapter in the D101.

Even if the temperature measurement data is not stored in D100 or D101, data registers D8260 or D8261 can be directly used in the arithmetic operation instruction or a PID instruction.

4.6 Averaging Time

Setting range: 1 to 4095

Initial value: K64

Numeric data type: Decimal (K)

If the averaging time is set for the TC-ADP, the averaged temperature measurement data will be stored in the D8260 to D8263, D8270 to D8273, D8280 to D8283, and D8290 to D8293. The averaging time can be set for each channel.

Set the averaging time in the following special data registers:

- FX3U, FX3UC Series PLC

Special data register				Description
1st	2nd	3rd	4th	
D8264	D8274	D8284	D8294	Averaging time for channel-1 data
D8265	D8275	D8285	D8295	Averaging time for channel-2 data
D8266	D8276	D8286	D8296	Averaging time for channel-3 data
D8267	D8277	D8287	D8297	Averaging time for channel-4 data

- FX3G Series PLC

Special data register		Description
1st	2nd	
D8284	D8294	Averaging time for channel-1 data
D8285	D8295	Averaging time for channel-2 data
D8286	D8296	Averaging time for channel-3 data
D8287	D8297	Averaging time for channel-4 data

1. Cautions regarding averaging time setting

- If the averaging time is set to "1", the immediate data will be stored in the temperature measurement special data register.
- If the averaging time is set to "2" or more, the average value will be calculated in accordance with the set averaging time, and the average value obtained will be stored in the temperature measurement special data register.
- After turning the PLC power on, the average data will be stored in the temperature measurement special data registers (D8260 to D8263, D8270 to D8273, D8280 to D8283, and D8290 to D8293) until the number of data items is increased to the set averaging time.
- Set the averaging time in the range from 1 to 4095. If the set value is outside the setting range, the error signal will be output.
- If the averaging time is set to "0" or smaller, the PLC will perform as if the averaging time is set to "1".
 If the averaging time is set to "4096" or larger, the PLC will perform as if the averaging time is set to "4096".
 → For a detailed description of error status, refer to Section 5.5

2. Program Example (For FX3U, FX3UC Series PLC)

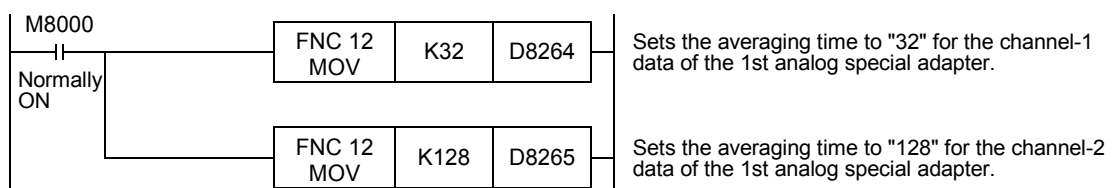

4.7 Error Status

If an error is detected on TC-ADP, the error status data will be stored in the corresponding special data register.

The following table shows the special data registers that store the error status data:

- FX3U, FX3UC Series PLC

Special data register				Description
1st	2nd	3rd	4th	
D8268	D8278	D8288	D8298	Stores the error status data.

- FX3G Series PLC

Special data register		Description
1st	2nd	
D8288	D8298	Stores the error status data.

Check the ON/OFF status of each bit of the error status data register to determine the error. Errors are assigned to the bits as shown in the following table. Create a program to detect errors.

Bit	Description	Bit	Description
b0	The temperature measurement data of channel 1 is outside the specified range, or disconnection is detected.	b5	Averaging time setting error
b1	The temperature measurement data of channel 2 is outside the specified range, or disconnection is detected.	b6	TC-ADP hardware error
b2	The temperature measurement data of channel 3 is outside the specified range, or disconnection is detected.	b7	TC-ADP communication data error
b3	The temperature measurement data of channel 4 is outside the specified range, or disconnection is detected.	b8 to b15	Unused
b4	EEPROM error	-	-

1. Caution regarding use of error status data

If a TC-ADP hardware error (b6) or TC-ADP communication data error (b7) is once detected, it is necessary to clear the error status with a program at next power-on of the PLC.

For this reason, be sure to create the following program:

- For FX3G, FX3U, FX3UC Series PLC

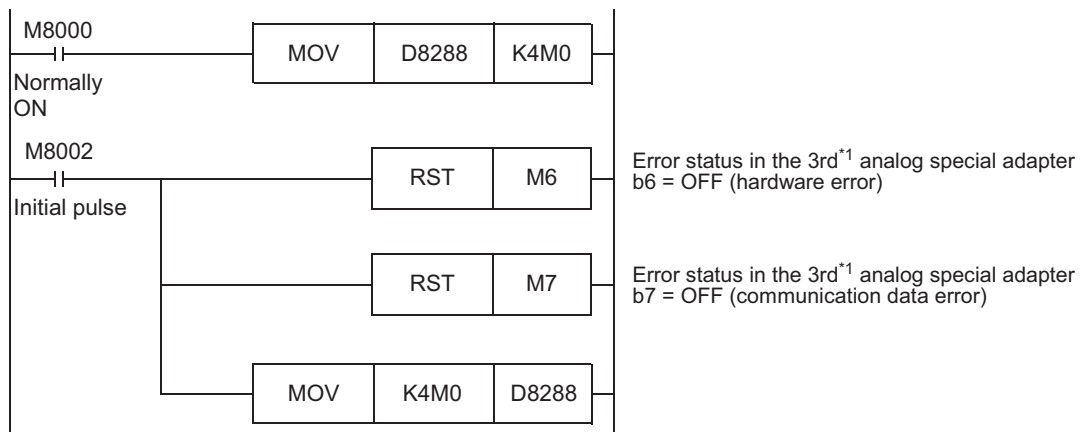

*1. "1st" for the FX3G PLC.

- For FX3U, FX3UC Series PLC

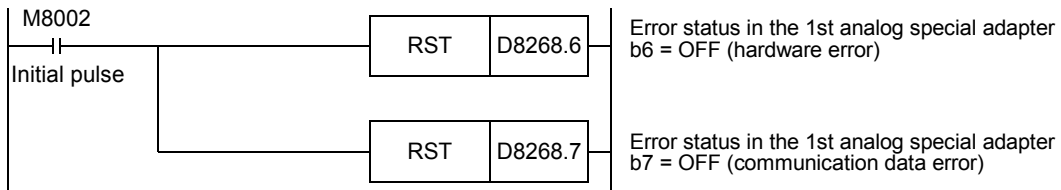

2. Program Example 1 (For FX3G, FX3U, FX3UC Series PLC)

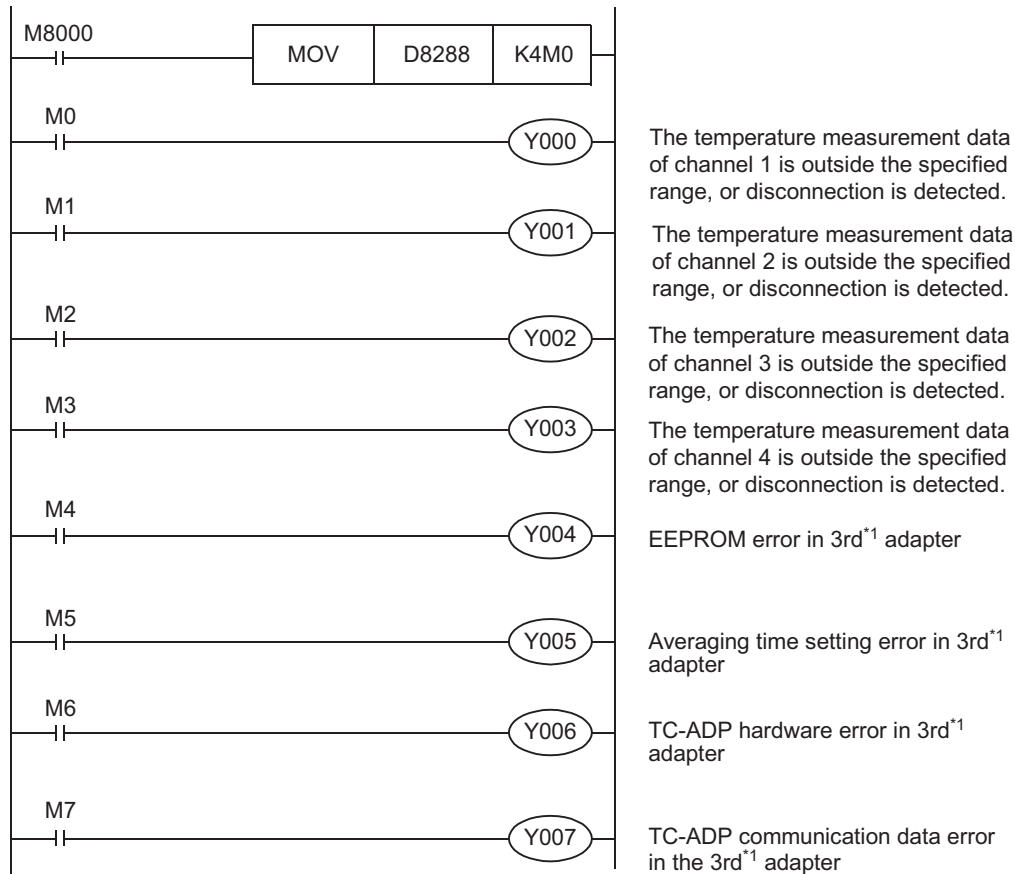

*1. "1st" for the FX3G PLC.

3. Program Example 2 (For FX3U, FX3UC Series PLC)

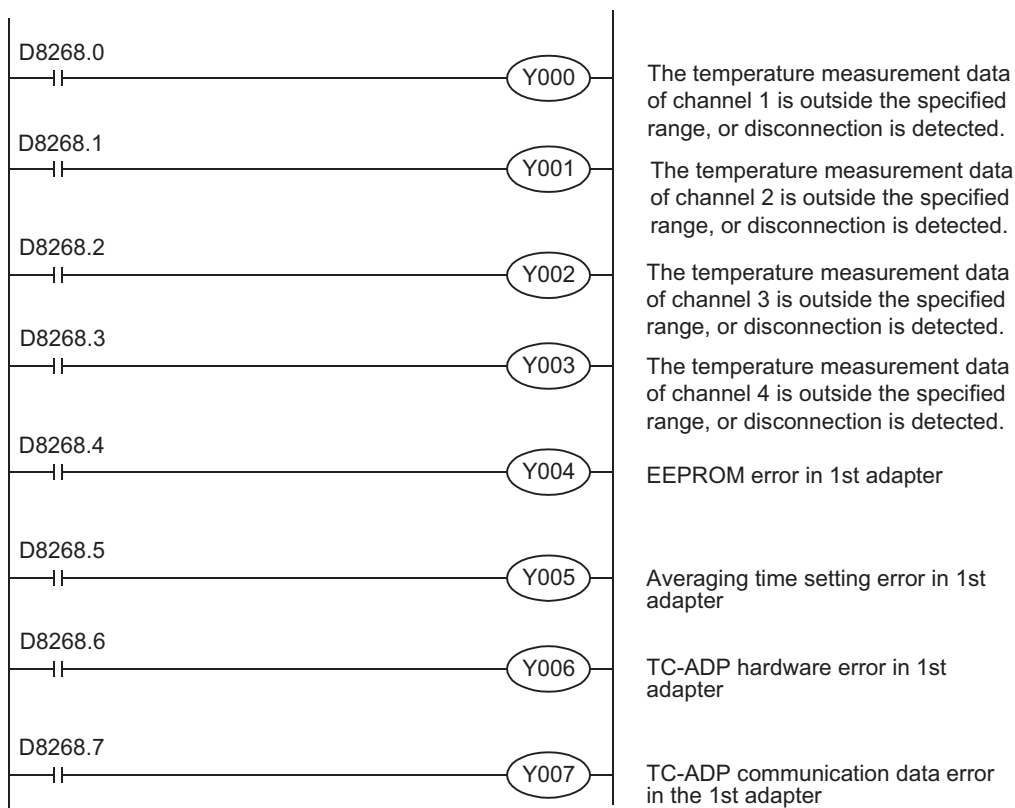

4.8 Model Code

Initial value: K10

Numeric data type: Decimal (K)

When the TC-ADP is connected, model code "10" will be stored in the special data register.
 The following table shows the special data registers that store the model code:

- FX3U, FX3UC Series PLC

Special data register				Description
1st	2nd	3rd	4th	
D8269	D8279	D8289	D8299	Model code

- FX3G Series PLC

Special data register		Description
1st	2nd	
D8289	D8299	Model code

Use the above special data registers to check whether TC-ADP is connected or not.

1. Program Example (For FX3U, FX3UC Series PLC)

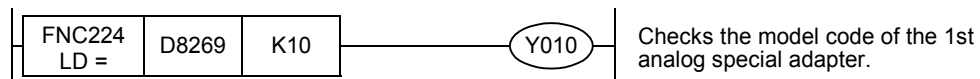

4.9 Basic Program Example

Create the following basic program to read out the temperature measurement data.

- For FX3G, FX3U, FX3UC Series PLCs

The following program will select thermocouple type K and will store the temperature measurement data (°C) of channels 1 and 2 of the 3rd^{*1} adapter in the D100 and the D101, respectively. The averaging time will be set to "32" for channel 1, and "128" for channel 2.

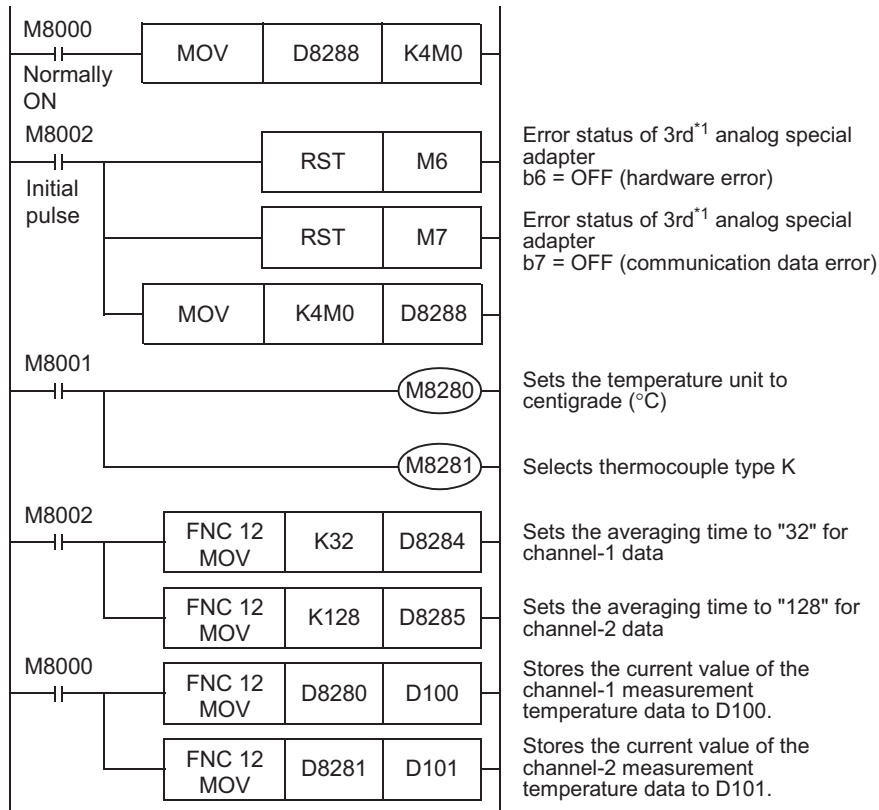

Even if the temperature measurement data is not stored to D100 or D101, data registers D8280 or D8281 can be directly used in the arithmetic operation instruction or a PID instruction.

*1. "1st" for the FX3G PLC.

- For FX3U, FX3UC Series PLC

The following program will select thermocouple type K and will store the temperature measurement data (°C) of channels 1 and 2 of the 1st adapter in the D100 and the D101, respectively. The averaging time will be set to "32" for channel 1, and "128" for channel 2.

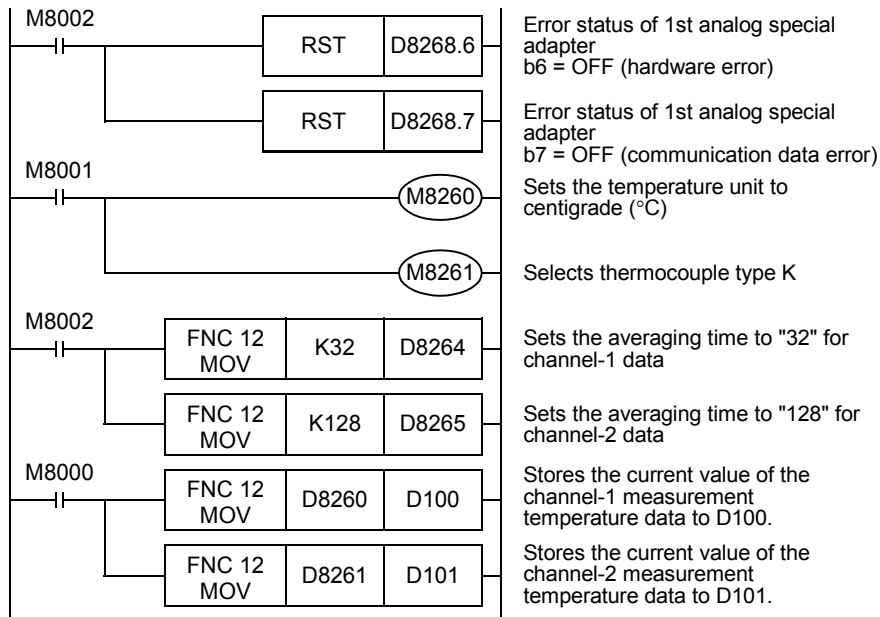

Even if the temperature measurement data is not stored to D100 or D101, data registers D8260 or D8261 can be directly used in the arithmetic operation instruction or a PID instruction.

5. Troubleshooting

This chapter describes the troubleshooting methods and error status.

If the temperature measurement data is not input, or if the proper digital value is not input, check the following items:

- Version number of the PLC
- Wiring
- Special devices
- Programs
- Error status

5.1 PLC Version Number Check

- Any versions (from Ver.2.20 (initial version) to the latest version) of the FX3U Series are compatible.
- Check the version number of FX3UC Series. The version number should be 1.30 or later.
- Any versions (from Ver.1.00 (initial version) to the latest version) of the FX3G Series are compatible.
→ For a detailed description of the version number check method, refer to Section 1.3.

5.2 Wiring Check

Check the following items for wiring:

1. Power

The TC-ADP needs driving power. Verify that the power supply line is properly connected. Also check that the POWER indicator lamp of the TC-ADP is on.

2. Thermocouple cable

Use a non-grounded type thermocouple and connect the thermocouple using the compensating lead wire. In addition, separate the cable of the thermocouple from the other power cables or inductive cables.

3. To use thermocouple type J

To use thermocouple type J, shortcircuit the J-type terminals. If these terminals are not shortcircuited, the temperature measurement data cannot be read out correctly.

→ For a detailed description of wiring, refer to Chapter 3.

5.3 Special Device Check

Check whether the special devices for the TC-ADP are correctly used:

1. Selection of type K or J

Check if the special device for type K/J selection is correctly set.

Turn off the device to select thermocouple type K. Turn on the device to select thermocouple type J.

2. Temperature measurement

Check if the special device of the selected channel is correctly set.

This special device should be selected depending on the connecting position and the channel.

3. Averaging time

Verify if the set averaging time is within the specified range. The averaging time should be set in the range from 1 to 4095. If the set averaging time is outside the specified range, an error occurs.

4. Error status

Check that no error is detected in the TC-ADP.

If an error is detected, check the details of the error, and then check the wiring and programs.

→ For a detailed description of special devices, refer to Chapter 4.

5.4 Program Check

Check the following items for the program:

1. Cancellation of error status at power-on

When the power is turned off and then on again, the error status should be cleared (the b6 and the b7 should turn off) using the program.

2. Check of storage devices

Verify that different values are not being stored in the same device by the other parts of the programs.

5.5 Error Status Check

If an error occurs in the TC-ADP, the corresponding bit will turn on.

The bit which is turned ON due to the error status is held ON until overwritten to OFF by the program or the power is cycled. If b6 or b7 is turned ON, then it is necessary to clear the error status using the program the next time the power of the PLC is cycled.

Bit	Description	Bit	Description
b0	The temperature measurement data of channel 1 is outside the specified range, or disconnection is detected.	b5	Averaging time setting error
b1	The temperature measurement data of channel 2 is outside the specified range, or disconnection is detected.	b6	TC-ADP hardware error
b2	The temperature measurement data of channel 3 is outside the specified range, or disconnection is detected.	b7	TC-ADP communication data error
b3	The temperature measurement data of channel 4 is outside the specified range, or disconnection is detected.	b8 to b15	Unused
b4	EEPROM error	-	-

To solve a problem, refer to the troubleshooting method described below:

1. Temperature measurement out of specified range or disconnection of line (b0 to b3)

1) Description of error

The input temperature measurement value is outside the specified range.

The temperature measurement value of thermocouple type K is not in the range between -110°C to $+1010^{\circ}\text{C}$, or the temperature measurement value of thermocouple type J is not in the range between -110°C to $+610^{\circ}\text{C}$.

Or the line between TC-ADP and the thermocouple is disconnected.

2) Remedy

Check that the input temperature measurement value is within the specified range.

Also check the wiring condition.

2. EEPROM error (b4)

1) Description of error

The adjustment data set in the EEPROM before delivery from our factory is unreadable or is destroyed.

2) Remedy

Please contact the nearest Mitsubishi Electric distributor office.

3. Averaging time setting error (b5)

1) Description of error

The averaging time set for one of the channels (channels 1 to 4) is outside the specified range: 1 to 4095.

2) Remedy

Check that the averaging time is correctly set for each channel.

4. TC-ADP hardware error (b6)

- 1) Description of error
The TC-ADP does not operate properly.
- 2) Remedy
Check that the 24V DC power is properly supplied to the TC-ADP.
Also check that the TC-ADP is correctly connected to the PLC.
If the problem cannot be solved even after the above check, please contact the nearest Mitsubishi Electric distributor office.

5. TC-ADP communication data error (b7)

- 1) Description of error
A communication error is detected between the TC-ADP and the PLC.
- 2) Remedy
Check that the TC-ADP is correctly connected to the PLC.
If the problem cannot be solved even after the above check, please contact the nearest Mitsubishi Electric distributor office.

MEMO

FX3G/FX3U/FX3UC Series Programmable Controllers

User's Manual [Analog Control Edition] PID Instruction (FNC 88)

Foreword

This manual describes the control methods for using the PID instruction in combination with analog products and should be read and understood before attempting to install or use the unit. Store this manual in a safe place so that you can take it out and read it whenever necessary. Always forward it to the end user.

This manual confers no industrial property rights or any rights of any other kind, nor does it confer any patent licenses. Mitsubishi Electric Corporation cannot be held responsible for any problems involving industrial property rights which may occur as a result of using the contents noted in this manual.

© 2005 MITSUBISHI ELECTRIC CORPORATION

1. Outline

This chapter describes the outline of PID instruction (FNC88) for the FX3U/FX3UC/FX3G Series PLC.

1.1 Outline of function

The PID instruction requires the system to calculate the output (MV) value from the measured (PV) value. Through combining the P (proportional) action, I (integral) action, and D (derivative) action the target (SV) value can be obtained. See diagram below.

- 1) Alarm output function
The alarm function can be set for input variation (measured value) or output variation (value).
- 2) Setting limit values
The upper limit and lower limit can be set for the output value.
- 3) Auto-tuning function
The proportional gain (KP), integral time (TI) and differential time (TD) can be set automatically for both the limit cycle method and step response method.
- 4) Operation method of the PID instruction
Both PID speed type operation and measured value differential type operation are executed.

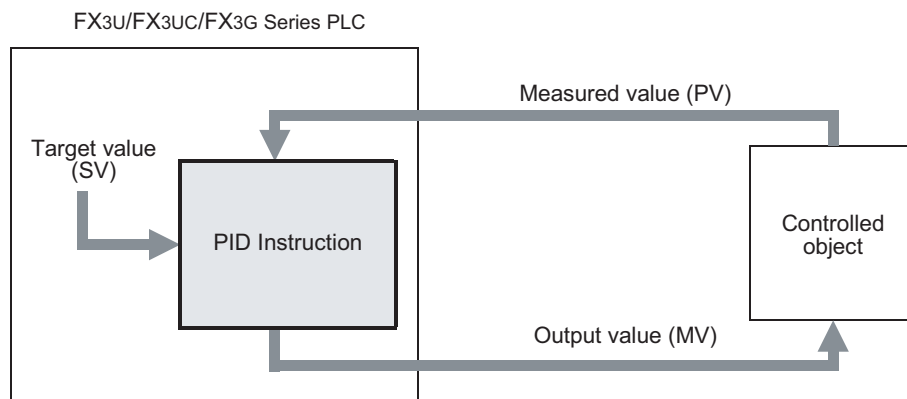

1.2 Basic Operation Expressions in PID Instruction (Reference)

The PID instruction executes using the speed type or measured value differential type operation expression. According to the contents of (S3) +1, bit 0 (operation setting (ACT)) specified by (S3) in the PID control, either for forward operation or backward operation is executed. Each value required in the operation is specified by a corresponding parameter (S3) or later.

1. Basic operation expression for PID control

Operation direction (ACT) (S3) +1, b0	PID operation expression
Forward operation (OFF)	$\Delta MV = KP\{(EVn - EVn-1) + \frac{TS}{TI} EVn + Dn\}$ $EVn = PVnf - SV$ $Dn = \frac{TD}{TS + KD \cdot TD} (-2PVnf-1 + PVnf + PVnf-2) + \frac{KD \cdot TD}{TS + KD \cdot TD} \cdot Dn-1$ $MVn = \Sigma \Delta MV$
Backward operation (ON)	$\Delta MV = KP\{(EVn - EVn-1) + \frac{TS}{TI} EVn + Dn\}$ $EVn = SV - PVnf$ $Dn = \frac{TD}{TS + KD \cdot TD} (2PVnf-1 - PVnf - PVnf-2) + \frac{KD \cdot TD}{TS + KD \cdot TD} \cdot Dn-1$ $MVn = \Sigma \Delta MV$

1) Symbols

EVn	: Deviation in sampling at this time	Dn	: Differential term at this time
EVn-1	: Deviation in previous cycle	Dn-1	: Differential term in previous cycle
SV	: Target value	KP	: Proportional gain
PVnf	: Measured value in sampling at this time (after filter)	TS	: Sampling cycle
PVnf-1	: Measured value in previous cycle (after filter)	TI	: Integral constant
PVnf-2	: Measured value in two cycles before (after filter)	TD	: Differential constant
ΔMV	: Output variation	KD	: Differential gain
MVn	: Operation quantity at this time		

- 2) Expression for calculating the measured value (after the filter) in sampling at this time (PVnf)
 The value "PVnf" is obtained from the following expression based on the read measured value.

$$\text{Measured value after filter: } PVnf = PVn + L(PVnf-1 - PVn)$$

PVn	: Measured value in sampling at this time
L	: Filter coefficient
PVnf-1	: Measured value in previous cycle (after filter)

2. How to Use PID Instruction

1. Instruction format

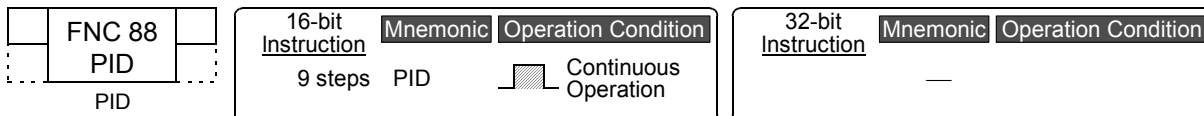

2. Set data

Operand type	Description	Data type
(S1)	Data register storing the target value (SV)	Binary 16-bit
(S2)	Data register storing the measured value (PV)	Binary 16-bit
(S3)	Data register storing PID parameters	Binary 16-bit
(D)	Data register storing the output value (MV)	Binary 16-bit

3. Target devices

Operand type	Bit devices							Word devices										Others						
	System User							Digit Specification				System User				Special Unit	Index		Constant	Real Number	Character String	Pointer		
	X	Y	M	T	C	S	D□.b	KnX	KnY	KnM	KnS	T	C	D	R	U□\G□	V	Z	Mod-ify	K	H	E	"□"	P
(S1)														✓	✓	▲								
(S2)														✓	✓	▲								
(S3)														✓	✓									
(D)														✓	✓	▲								

▲ : Only available for FX3U and FX3UC PLCs.

2.1 Explanation of function and operation

1. 16-bit PID operation

Once the target value (S1), measured value (S2) and PID parameters (S3) to (S3) + 6 are set and the program is executed, the operation result (MV) is transferred to the output value (D) at every sampling time. The sampling time is specified by (S3)

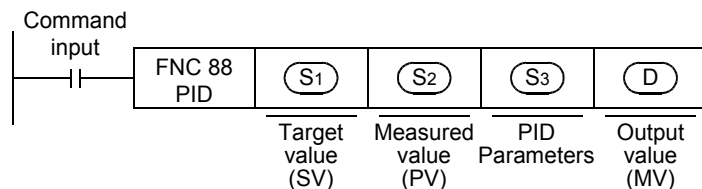

Explanation of set items

Set item	Description	Occupied points
(S1) Target value (SV)	<ul style="list-style-type: none"> The target value (SV) is set. The PID instruction does not change the settings. Caution on using the auto-tuning (limit cycle method) If the target value for auto-tuning is different from the target value in the PID control, it is necessary to set a value to which a bias value is added, and then store the actual target value when the auto-tuning flag turns OFF. 	1
(S2) Measured value (PV)	This is the input value of the PID operation.	1
(S3) Parameter*1	1) Auto-tuning (in the limit cycle) Twenty-nine devices are occupied from the head device specified in (S3).	29
	2) Auto-tuning (in the step response method) a) Operation setting (ACT): When bits 1, 2 and 15 are something other than "0" Twenty-five devices are occupied from the head device specified in (S3).	25
	b) Operation setting (ACT): When bits 1, 2 and 15 are "0" Twenty devices are occupied from the head device specified in (S3).	20
(D) Output value (MV)	1) PID control (normal processing) The user sets the initial output value before driving the instruction. After that, the operation result is stored. 2) Auto-tuning (in the limit cycle method) The Upper Limit Value (ULV) or Lower Limit Value (LLV) value is automatically output during auto-tuning. The specified MV value is output when auto-tuning is finished. 3) Auto-tuning (in the step response method) The user sets the step output value before driving the instruction. The MV value is not changed by PID instruction during auto-tuning.	1

*1. When auto-tuning is not executed for the limit cycle method, the same number of devices as those occupied in the step response method become occupied.

2.2 Relationship Between Parameter Setting and Auto-Tuning

1. When auto-tuning is not executed (parameter setting)

It is necessary to write the set value of the parameters (S3) to (S3)+6 using MOV instruction in advance, etc. before starting the PID operation when auto-tuning is not executed.
 When data registers in the latch area are backed up against power failure, the setting data is held even after the power of the PLC is turned OFF. Therefore, writing is not necessary when the power is turned back ON.

2. When auto-tuning is executed

The proportional gain ((S3)+3), integral time ((S3)+4) and differential time ((S3)+6) are important constants for executing the auto-tuning function described later and for optimizing the PID control. These constants can be set automatically.

- For a detailed description of auto-tuning (limit cycle method), refer to Section. 4.1.
- For a detailed description of auto-tuning (step response method), refer to Section. 4.2.

3. Parameter

This chapter describes various parameters of PID instruction.

3.1 Parameter List: (S3) to (S3) + 28

Set item	Setting	Remarks	Reference	
(S3)	Sampling time (TS)	1 to 32767 (ms)	It cannot be shorter than operation cycle of the PLC. Subsection 3.2.1	
(S3) +1	Operation setting (ACT)	bit0	0: Forward operation 1: Backward operation Operation direction	Subsection 3.2.2
		bit1	0: Input variation alarm is invalid. 1: Input variation alarm is valid.	
		bit2	0: Output variation alarm is invalid. 1: Output variation alarm is valid. Do not set to ON bit 2 and bit 5 at same time.	
		bit3	Not available	
		bit4	0: Auto-tuning is not executed. 1: Auto-tuning is executed.	
		bit5	0: Upper and lower limits of output value are not valid. 1: Upper and lower limits of output value are valid. Do not set to ON bit 2 and bit 5 at same time.	
		bit6	0: Step response method 1: Limit cycle method Select auto-tuning mode.	
bit7 to bit15	Not available			
(S3) +2	Input filter constant (α)	0 to 99 (%)	When "0" is set, input filter is not provided. Subsection 3.2.3	
(S3) +3	Proportional gain (KP)	1 to 32767 (%)	Subsection 3.2.4	
(S3) +4	Integral time (TI)	0 to 32767 ($\times 100$ ms)	When "0" is set, it is handled as " ∞ " (no integration). Subsection 3.2.5	
(S3) +5	Differential gain (KD)	0 to 100 (%)	When "0" is set, differential gain is not provided. Subsection 3.2.6	
(S3) +6	Differential time (TD)	0 to 32767 ($\times 10$ ms)	When "0" is set, differential is not executed. Subsection 3.2.7	
(S3) +7 : (S3) +19	These devices are occupied for internal processing of PID operation. Do not change data.		—	

Set item		Setting	Remarks	Reference	
(S3) +20*1	Input variation (incremental) alarm set value	0 to 32767	It is valid when operation direction (ACT) (bit 1 of (S3) +1) is "1".	Subsection 3.2.2	
(S3) +21*1	Input variation (decremental) alarm set value	0 to 32767	It is valid when operation direction (ACT) (bit 1 of (S3) +1) is "1".		
(S3) +22*1	Output variation (incremental) alarm set value	0 to 32767	It is valid when operation direction (ACT) (bit 2 of (S3) +1) is "1" or (ACT) (bit 5 of (S3) +1) is "0".		
	Output upper limit set value	-32768 to 32767	It is valid when operation direction (ACT) (bit 2 of (S3) +1) is "0" or (ACT) (bit 5 of (S3) +1) is "1"		
(S3) +23*1	Output variation (decremental) alarm set value	0 to 32767	It is valid when operation direction (ACT) (bit 2 of (S3) +1) is "1" or (ACT) (bit 5 of (S3) +1) is "0"		
	Output lower limit set value	-32768 to 32767	It is valid when operation direction (ACT) (bit 2 of (S3) +1) is "0" or (ACT) (bit 5 of (S3) +1) is "1"		
(S3) +24*1	Alarm output	bit0	0: Input variation (incremental) is not exceeded. 1: Input variation (incremental) is exceeded.	It is valid when operation direction (ACT) (bit 1 or bit 2 of (S3) +1) is "1".	Subsection 3.2.8
		bit1	0: Input variation (decremental) is not exceeded. 1: Input variation (decremental) is exceeded.		
		bit2	0: Output variation (incremental) is not exceeded. 1: Output variation (incremental) is exceeded.		
		bit3	0: Output variation (decremental) is not exceeded. 1: Output variation (decremental) is exceeded.		
The setting below is required when the limit cycle method is used (when the operation direction (ACT) b6 is set to ON).					
(S3) +25	PV value threshold (hysteresis) width (SHPV)	Set it according to measured value (PV) fluctuation.	They are occupied when operation direction (ACT) (bit 6) is "ON (limit cycle method)."	Chapter 4	
(S3) +26	Output value upper limit (ULV)	Set maximum value (ULV) of output value (MV).			
(S3) +27	Output value lower limit (LLV)	Set minimum value (LLV) of output value (MV).			
(S3) +28	Wait setting from end of tuning cycle to start of PID control (KW)	-50 to 32717%			

*1. (S3) +20 to +24 become occupied only if bits 1, 2, or 5 are set to "1" to determine the action (ACT) of (S3) +1.

3.2 Details of Parameters

3.2.1 Sampling time (Ts): (S3)

Setting range: 1 to 32767 [ms]

Set the cycle time (ms) for the PID operation.

- In PID control and auto-tuning (Limit cycle method)
Set the sampling time longer than the operation cycle of the PLC.
- In auto-tuning (Step response method)
Set the sampling time to 1,000 ms (= 1 second) or more.

1. Maximum error

The maximum error of the sampling time (Ts) is from "-(one operation cycle + 1 ms)" to "+(one operation cycle)."

- 1) When the sampling time (Ts) is a small value
Fluctuation of the maximum error described above may cause a problem.
In such a case, execute the PID instruction in the constant scan mode, or program it in a timer interrupt routine.
- 2) When the sampling time (Ts) is shorter than one operation cycle of the PLC
A PID operation error (K6740) occurs, however when PID operation is executed, the sampling time (Ts) is equal to the operation cycle of the PLC.
In such a case, use the PID instruction in a timer interrupt (I6□□ to I8□□), and clear (S3) +7 just before executing the PID instruction.

→ For a detailed description, refer to **FX3G/ FX3U/FX3uc Series Programming Manual - Basic & Applied Instruction Edition**

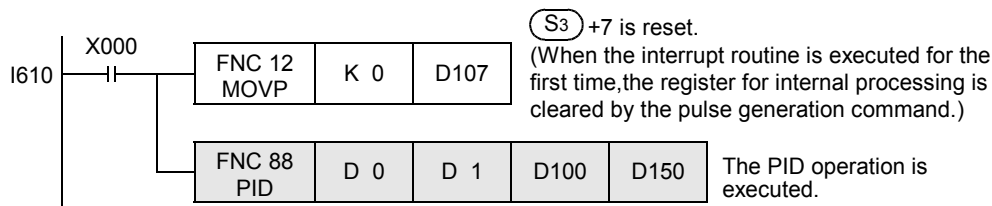

3.2.2 Operation setting (ACT):(S3)+1

Setting range: OFF = forward operation, ON = backward operation

1. Forward operation or backward operation: (S3) +1, bit 0

Select the PID control direction (forward or backward).

- During auto-tuning for the limit cycle method
 It is necessary to set the PID control direction (forward or backward) for auto-tuning.
- During auto-tuning for the step response method
 The PID control direction (forward or backward) is not required as, the direction is automatically set when auto-tuning is complete.

Forward operation: (S3) +1, bit 0 = 0

As the measured value (PV) becomes larger than the target value (SV), the output (MV) increases.
 For example, cooling is a forward operation.

<Cooling>

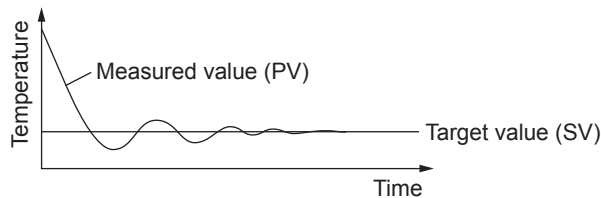

Backward operation: (S3) +1, bit 0 = 1

As the measured value (PV) becomes smaller than the target value (SV), the output (MV) increases.
 For example, heating is a backward operation.

<Heating>

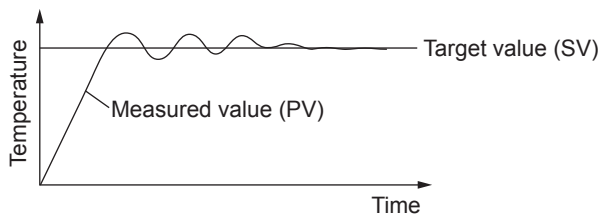

Relationship between the forward/backward operation and the output (MV), measured value (PV) and target value (SV)

The relationship is as follows.

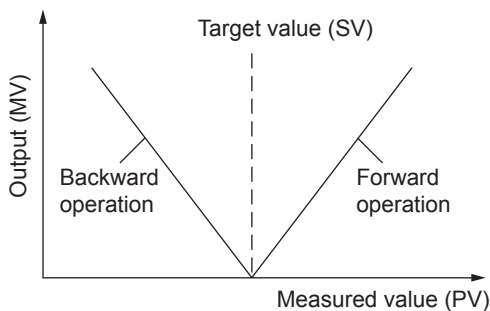

2. Alarm setting (for input variation and output variation): (S3) +1, bit 1 and bit 2
Setting range: OFF, ON

The input variation and output variation can be checked arbitrarily.
 These parameters can be set in (S3) +24.

→ For the operation of upper/lower limit alarm output for the input and output values, refer to Subsection 3.2.8.

Input variation: (S3) +1, bit 1

When using the input variation alarm, it is necessary to set to ON the following bits and set the values to be checked.

Set item			Setting (setting range)
Operation setting (ACT)	(S3) +1	bit1	Input variation alarm ON: Used OFF: Not used
Input variation alarm set value	(S3) +20		Input variation (incremental) alarm set value 0 to 32767
	(S3) +21		Input variation (decremental) alarm set value 0 to 32767

Output variation: (S3) +1, bit 2

When using the output variation alarm, it is necessary to set the following bits to ON and set the values to be checked.

Set item			Setting (setting range)
Operation setting (ACT)	(S3) +1	bit2	Output variation alarm ON: Used OFF: Not used
		bit5	Output value upper/lower limit setting Make sure to set it to OFF
Output variation alarm set value	(S3) +22		Output variation (incremental) alarm set value 0 to 32767
	(S3) +23		Output variation (decremental) alarm set value 0 to 32767

Variation means (Previous value) - (Current value)

3. Upper and lower limits for output value: (S3) +1, bit 5

Setting range: OFF = Setting is not provided., ON = Setting is provided.

The upper limit and lower limit of the output value work as shown in the graph below.

The upper limit and lower limit of the output value can moderate the increase of the integral item in the PID control.

When using the upper limit and lower limit of the output value, make sure to set (S3) +1, bit 2 is set to OFF.

Set item			Setting (setting range)
Operation setting (ACT)	(S3) +1(ACT)	bit2	Output variation alarm Make sure to set it to OFF
		bit5	Output value upper/lower limit setting ON: Used OFF: Not used

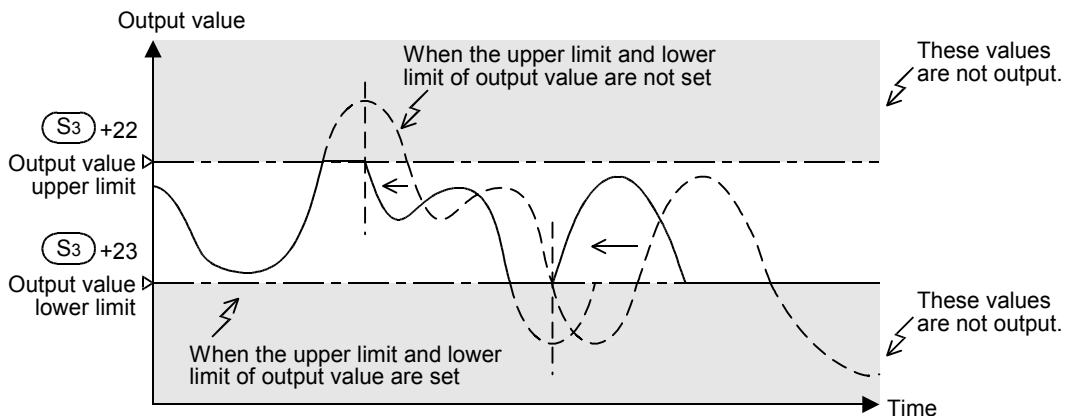

3.2.3 Input filter (α): (S3)+2

Setting range: 0 to 99[%]

PID control: Proportional operation, integral operation and differential operation

The input filter (α) is a software filter to reduce the fluctuation of the measured value (PV) caused by noise. By setting this time constant of the filter according to the control target characteristics and noise level, the effect of noise can be reduced.

- If the input filter value is too small, the filter effect is small.
- If the input filter value is too large, the input response is bad.

Because the input filter (α) is effective to the target value (SV), all of the proportional operation, integral operation and differential operation are affected.

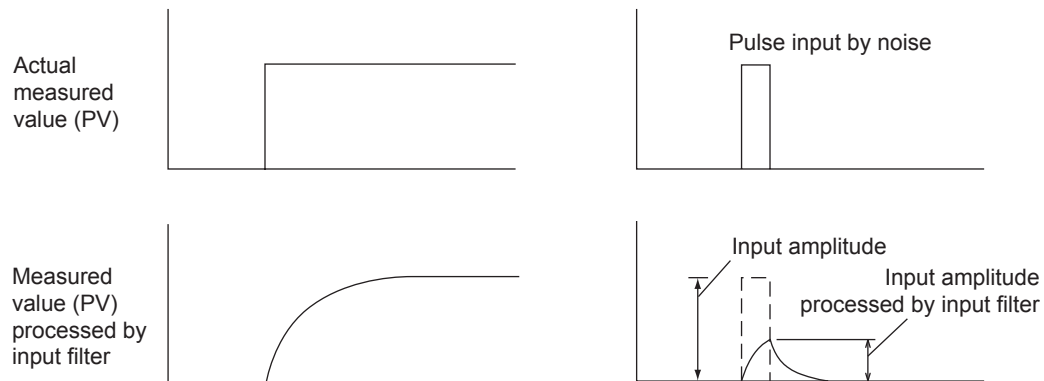

3.2.4 Proportional gain (Kp): (S3)+3

Setting range: 1 to 32767[%]
PID control: Proportional operation

During the proportional operation, the output (MV) increases in proportion to the deviation (difference between the target value (SV) and the measured value (PV)).

This deviation is called proportional gain (Kp), and expressed in the following relational expression:

$$\text{Output (MV)} = \text{Proportional gain (Kp)} \times \text{Deviation (EV)}$$

The reciprocal of the proportional gain (Kp) is called proportional band.

As the proportional gain (Kp) is larger (as shown in the example below), the motion to let the measured value (PV) be nearer to the target value (SV) becomes stronger.

Example 1: Proportional operation (P operation) in heating (backward operation)

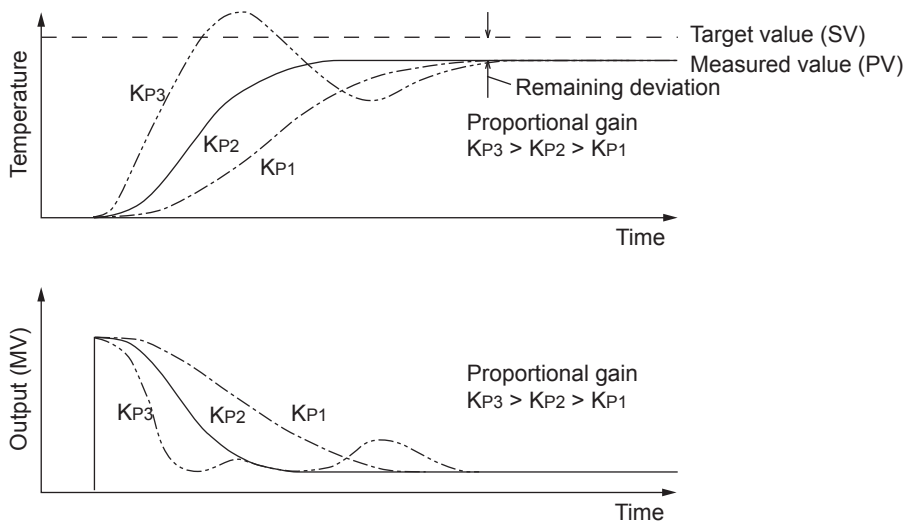

Example 2: Proportional operation (P operation) in cooling (forward operation)

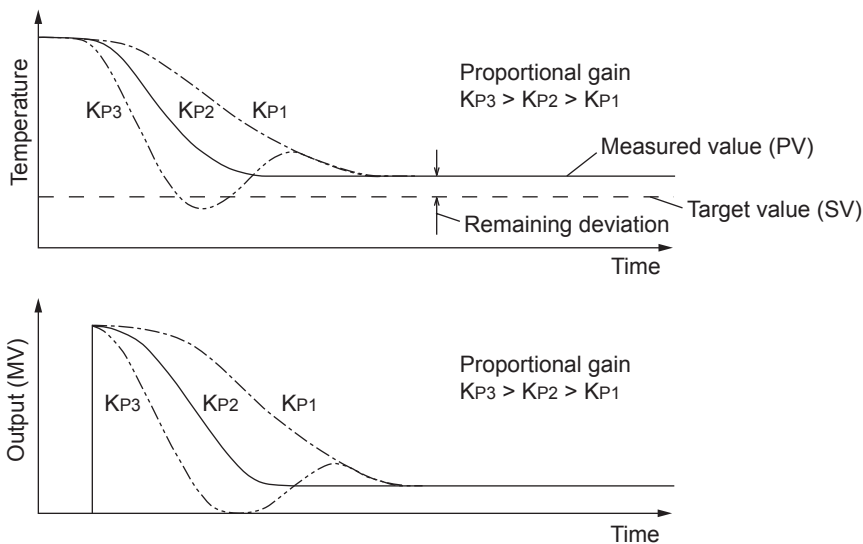

3.2.5 Integral time (Ti): (S3)+4

Setting range: 0 to 32767 [× 100 ms] "0" is handled as "∞" (no integration).
PID operation: Integral operation

During the integral operation, the time after deviation is generated until the integral operation output becomes the proportional operation output. This is called integral time and is expressed as "Ti".

As Ti becomes smaller, the integral operation becomes stronger.

Example 1: PI operation in heating (backward operation)

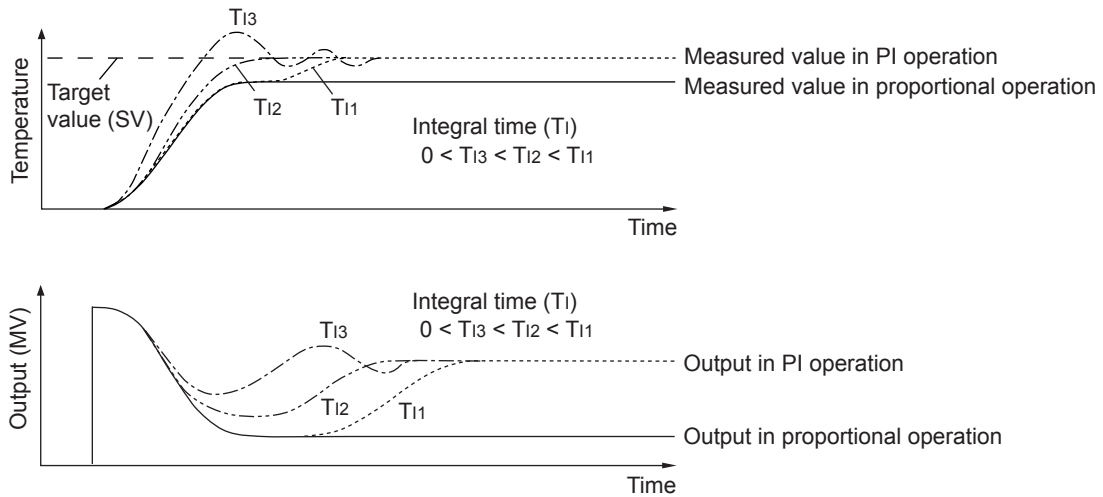

Example 2: Proportional operation (P operation) in cooling (forward operation)

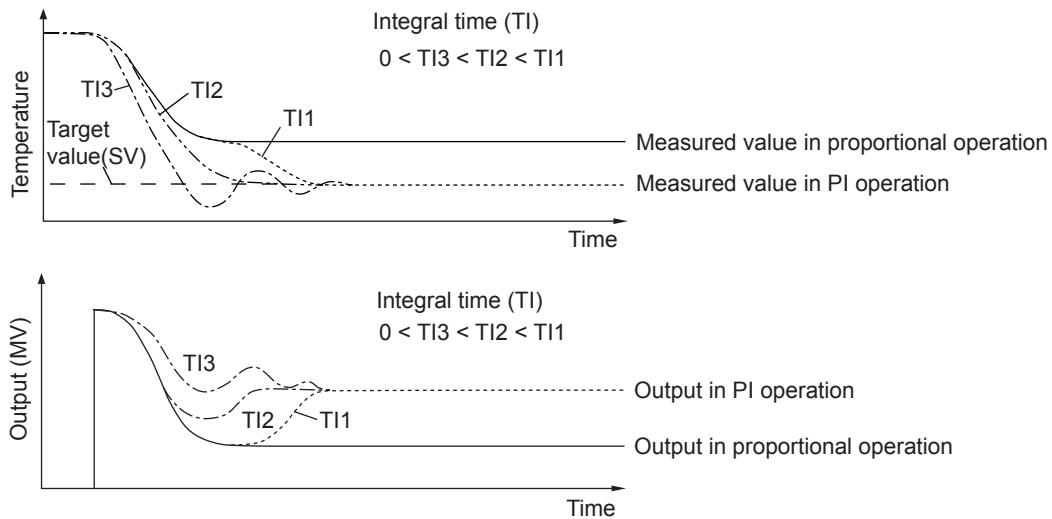

Important point

The integral operation changes the output so that the continuously generated deviation is eliminated. As a result, the remaining deviation generated in the proportional operation can be eliminated.

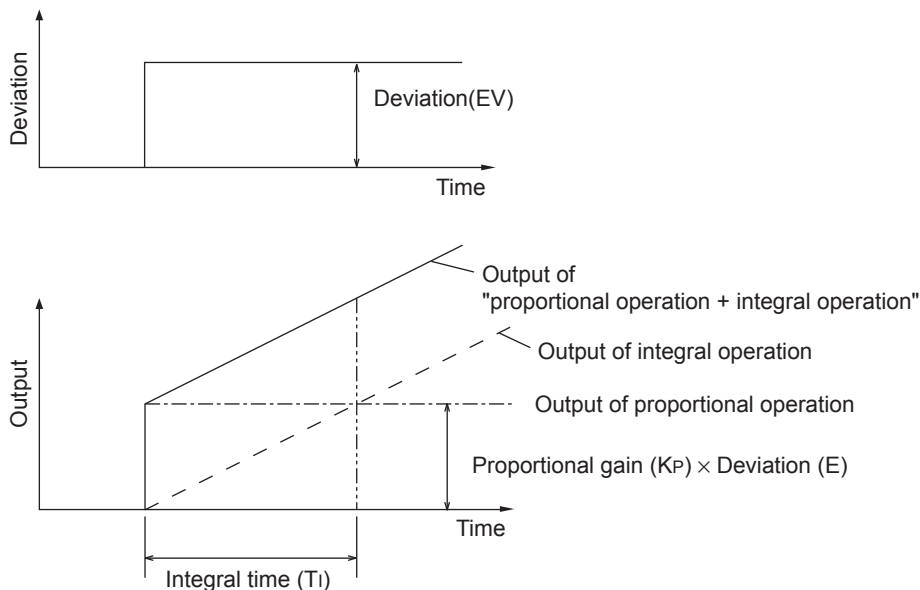

3.2.6 Differential gain (KD): (S3)+5

Setting range: 0 to 100[%]
PID control: Differential operation

The filter is applied to the output at the differential operation.
 Only the differential operation is affected by the differential gain (KD).

- When the differential gain (KD) is small, the output is immediately given with regard to changes in the measured value (PV) caused by disturbance, etc.
- When the differential gain (KD) is large, the output is given after a long time with respect to changes in the measured value (PV) caused by disturbance, etc.

Important points

Set the differential gain (KD) to "0", and then adjust the operation using the input filter (α).
 If the output response is too close to the disturbance, increase the differential gain (KD).

3.2.7 Differential time (TD): (S3)+6

Setting range: 0 to 32767 [$\times 10$ ms]
PID control: Differential operation

Use the differential time (TD) to respond sensitively to fluctuations in the measured value (PV) caused by disturbance, etc. and to minimize the fluctuations.

- When the differential time (TD) is large, it becomes to prevent large fluctuation in the control target caused by disturbance, etc.
- It is not always necessary to use the differential time (when disturbance is small, for example).

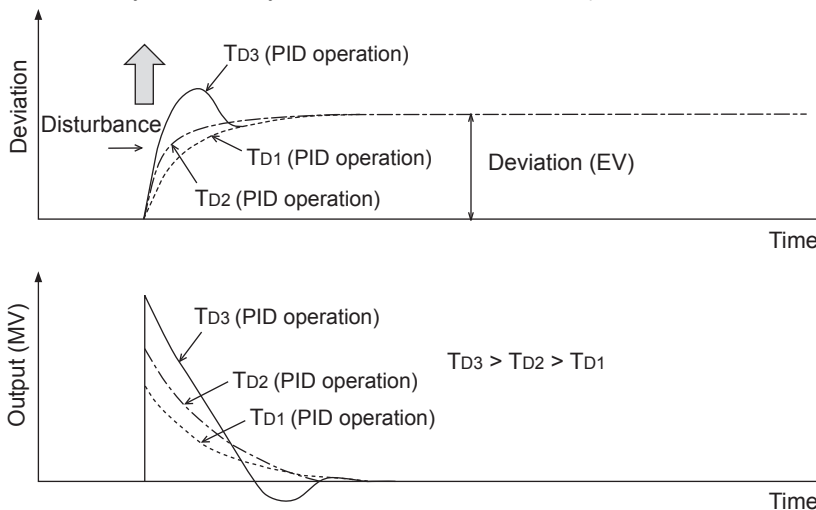

Example 1: PID operation in heating (backward operation)

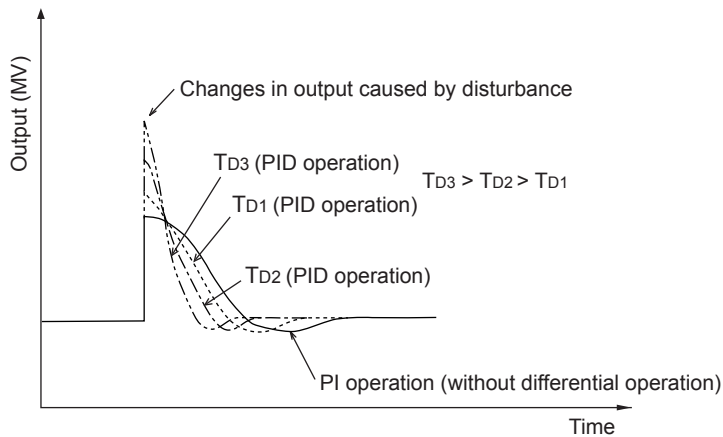
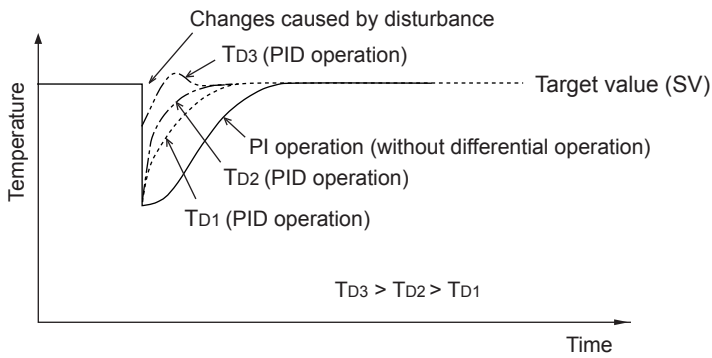

Example 2: PID operation in cooling (forward operation)

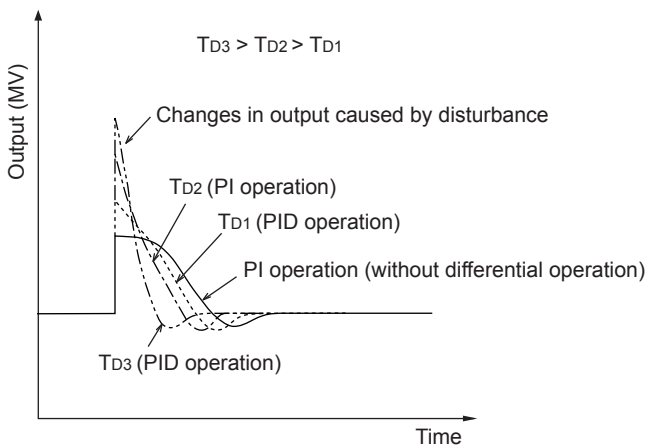
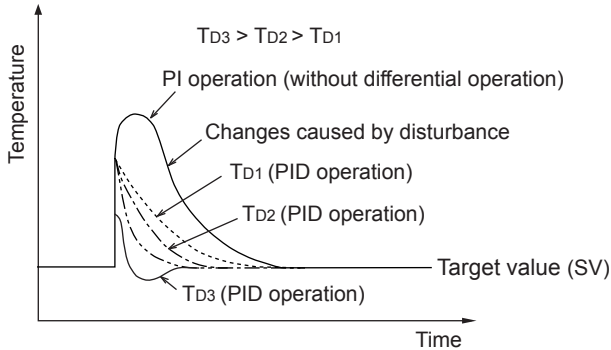

3.2.8 Alarm output flag: (S3)+24

When the input variation [(S3) +1, bit 1] is set to 1

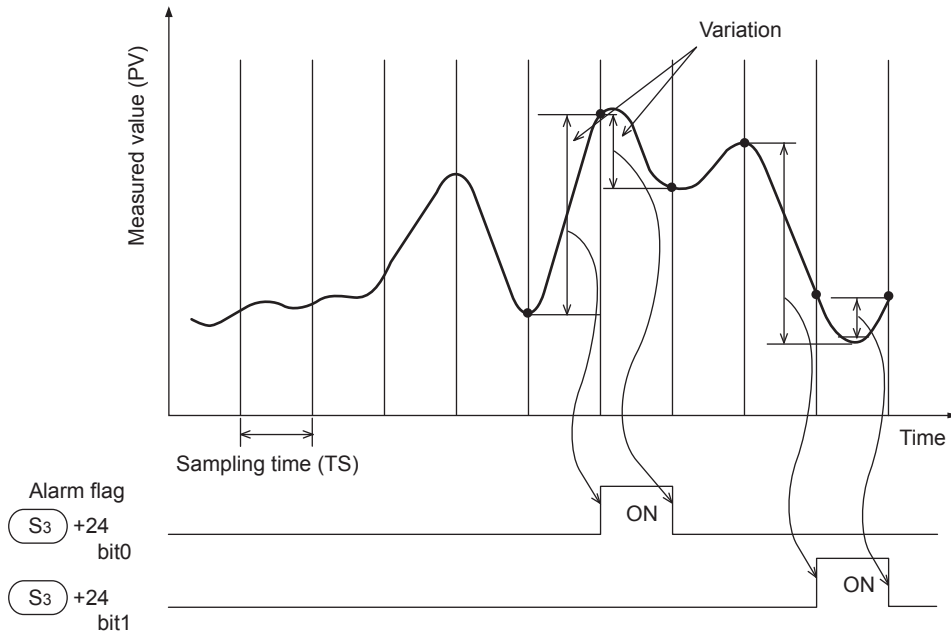

When the output variation [(S3) +1, bit 2] is set to 1

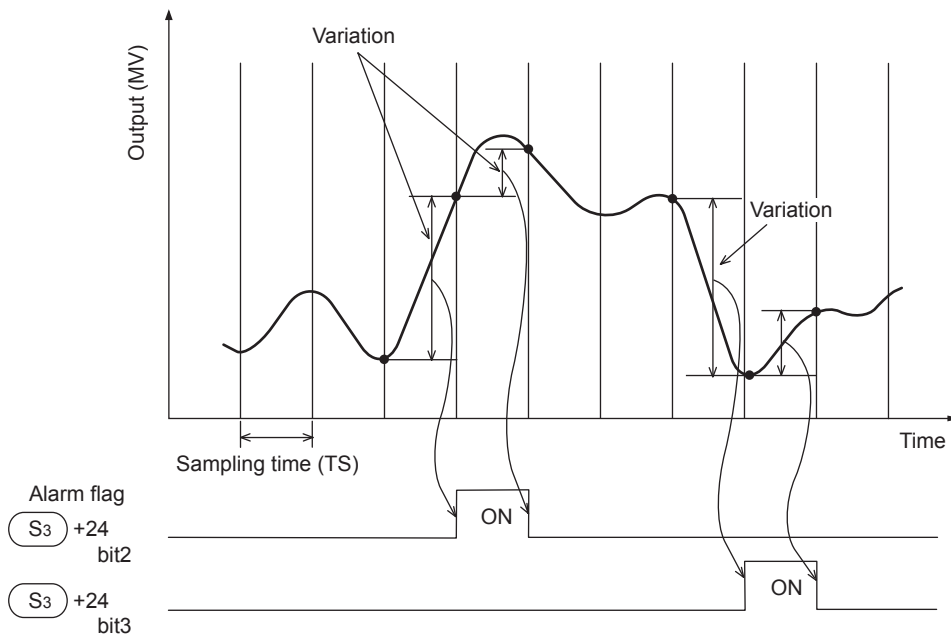

- When the preset input/output variation is exceeded:
 Each bit of (S3)+24 (alarm flags) turns ON immediately after PID instruction execution.

4. Auto-Tuning

This chapter describes the auto-tuning function of PID instruction.

The auto-tuning function will automatically set the important constants, such as the proportional gain and the integral time, to ensure optimum PID control.

There are two auto-tuning methods: limit cycle method and step response method.

4.1 Limit Cycle Method

4.1.1 Parameters set in auto-tuning (of limit cycle method)

Parameter	Setting position
Proportional gain (KP)	(S3) +3
Integral time (TI)	(S3) +4
Differential time (TD)	(S3) +6

4.1.2 Auto-tuning procedure

- 1 Set the forward or backward operation**
Set the operation direction flag (bit 0) in the operation setting parameter (ACT) $(S_3)+1$.
- 2 Select the auto-tuning method (limit cycle method)**
Set the auto-tuning method to ON (bit 6) in the operation setting parameter (ACT) $(S_3)+1$.
(When bit 6 is set to OFF, the step response method is selected.)
- 3 Set the auto-tuning execution flag to ON**
Set the auto-tuning execution flag to ON (bit 4) in the operation setting parameter (ACT) $(S_3)+1$.
- 4 Set the input filter**
Set the input filter in the operation setting parameter (ACT) $(S_3)+2$.
- 5 Set the sampling time**
Set the sampling time (S_3) .
- 6 Set the Upper Limit Value (ULV)**
Set the Upper Limit Value (ULV) of the output value (MV) in the operation setting parameter (ACT) $(S_3)+26$.
- 7 Set the Lower Limit Value (LLV)**
Set the Lower Limit Value (LLV) of the output value (MV) in the operation setting parameter (ACT) $(S_3)+27$.
- 8 Set the threshold (hysteresis) (SHPv)**
Set the threshold (hysteresis) width (SHPv) in the operation setting parameter (ACT) $(S_3)+25$.
- 9 Set the target value (SV)**
Set the target value (SV) to (S_1) in PID instruction.
- 10 Set the ON PID instruction command input to start auto-tuning**
Auto-tuning is executed according to the measured value (PV).
↓
When auto-tuning is completed, the auto-tuning flag (bit 4 and bit 6) turns OFF in the operation setting parameter (ACT) $(S_3)+1$.

4.1.3 Reference: How to obtain three constants in PID control (limit cycle method)

For acquiring satisfactory control results in PID control, it is necessary to obtain the optimal value of each constant (parameter) suitable to the control target.

This paragraph explains the limit cycle method to obtain the amplitude (a) and vibration cycle (τ , τ_{on}) of the input value, and then calculate the proportional gain (KP), integral time (TI) and differential time (TD) based on the expressions shown in the table below.

What is the limit cycle method

Changes in the input value in two-position control (in which the output Upper Limit Value (ULV) and output Lower Limit Value (LLV) are switched according to the deviation) are measured, and then three constants in the PID control are obtained.

Operation characteristics (in an example of backward operation)

During the " τ_w " period after the tuning cycle is finished, the output value is held at the output Lower Limit Value (LLV), and then normal PID control is started.

The value " τ_w " can be obtained by the expression " $\tau_w = (50 + K_w)/100 \times (\tau - \tau_{on})$ ", and the wait setting parameter " K_w " can be set in the parameter (S3) +28.

(Setting range: $K_w = -50$ to $+32717$ [%])

(When the abnormal range is specified, " τ_w " is handled as "0")

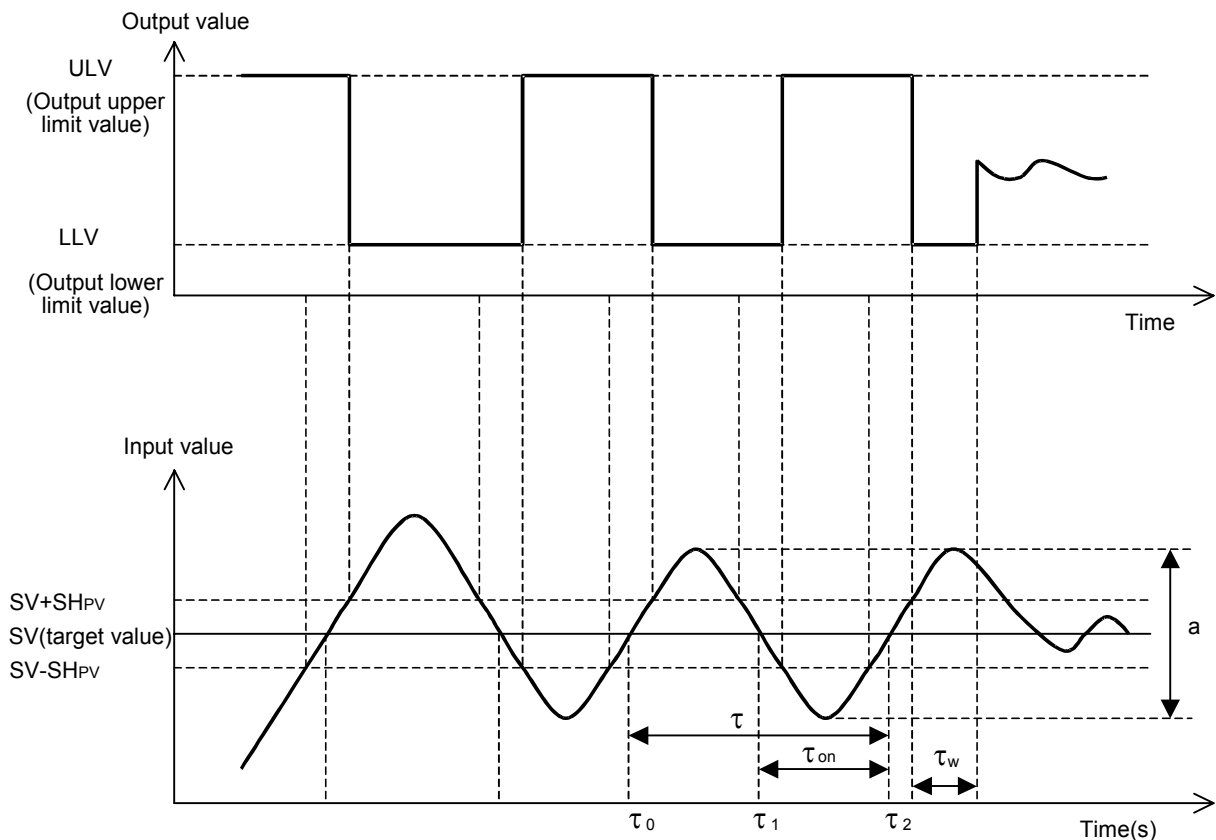

SHpV: PV input threshold (hysteresis)

Operation characteristics and three constants

Control type	Proportional gain (KP) [%]	Integral time (TI) [$\times 100$ ms]	Differential time (TD) [$\times 10$ ms]
Only proportional control (P operation)	$\frac{1}{a}(\text{ULV} - \text{LLV}) \times 100$	—	—
PI control (PI operation)	$\frac{0.9}{a}(\text{ULV} - \text{LLV}) \times 100$	$33 \times \tau_{on} \left(1 - \frac{\tau_{on}}{\tau}\right)$	—
PID control (PID operation)	$\frac{1.2}{a}(\text{ULV} - \text{LLV}) \times 100$	$20 \times \tau_{on} \left(1 - \frac{\tau_{on}}{\tau}\right)$	$50 \times \tau_{on} \left(1 - \frac{\tau_{on}}{\tau}\right)$

4.2 Step Response Method

4.2.1 Parameters to be set by auto-tuning (step response method)

Parameter	Setting position	Parameter	Setting position
Operation setting (ACT)	(S3) +1, bit 0 (operation direction)	Integral time (Ti)	(S3) +4
Proportional gain (KP)	(S3) +3	Differential time (TD)	(S3) +6

4.2.2 Auto-tuning procedure

1 Transferring the output value for auto-tuning to the output value (D)

Set the output value for auto-tuning to the maximum available output value multiplied by 0.5 to 1 for the output equipment.

2 Setting the parameter (S3), target value (SV), etc. that cannot be set in auto-tuning according to the system

Note that auto-tuning may not be executed normally if the cautions described below are not followed

1. Set items

Set item and parameter	Remarks
Target value (SV) (S1)	The difference from the measured value (PV) should be 150 or more. (For the details, refer to "2. Cautions on setting" below.)
Sampling time (Ts) (S3)	1,000 ms or more (For the details, refer to "2. Cautions on setting" below.)
Input filter (α) (S3) +2	
Differential gain (KD) (S3) +5	When setting the input filter, set the differential gain to "0" usually.
Others	Set other items, as necessary.

2. Cautions on setting

- 1) Difference between the target value (SV) and the measured value (PV)
 If the difference between the target value (SV) and the measured value (PV) is less than 150 when auto-tuning is started, auto-tuning is not executed normally.
 Accordingly, if the difference is less than 150, set the target value for auto-tuning.
 Set the target value again when auto-tuning is completed.

Set item	Setting in PID instruction	
Target value (SV)	(S1)	Make sure that the difference from the measured value is 150 or more when auto-tuning is started.

- 2) Sampling time (Ts) (S3)
 Make sure the sampling time is set for auto-tuning to 1 second (1000 ms) or more.
 It is recommended that the sampling time is set to that it is considerably longer than the output change cycle.

3 Setting to ON bit 4 of (S3) +1 (operation setting ACT) to start auto-tuning

When the variation from the measured value at the start of auto-tuning to the target value reaches 1/3 or more, auto-tuning is completed. And bit 4 of (S3) +1 (operation setting ACT) is automatically set to OFF.

1. Important point

Start auto-tuning while the system is stable.
 If the system is unstable when auto-tuning is started, auto-tuning may not be executed normally.

4.2.3 Reference: How to obtain three constants in PID control (step response method)

For acquiring satisfactory control results during PID control, it is necessary to obtain the optimal value of each constant (parameter) suitable for the control target.

This paragraph explains the step response method to obtain three constants in the PID control (proportional gain (KP), integral time (Ti) and differential time (TD)).

What is the step response method

In this method, by giving stepped output from 0 to 100%*1 to the control system, three constants in the PID control are obtained from the operation characteristics (maximum ramp (R) and dead time (L)) and the input value variation.

*1. The stepped output may be obtained from 0 to 75% or from 0 to 50%.

Operation characteristics

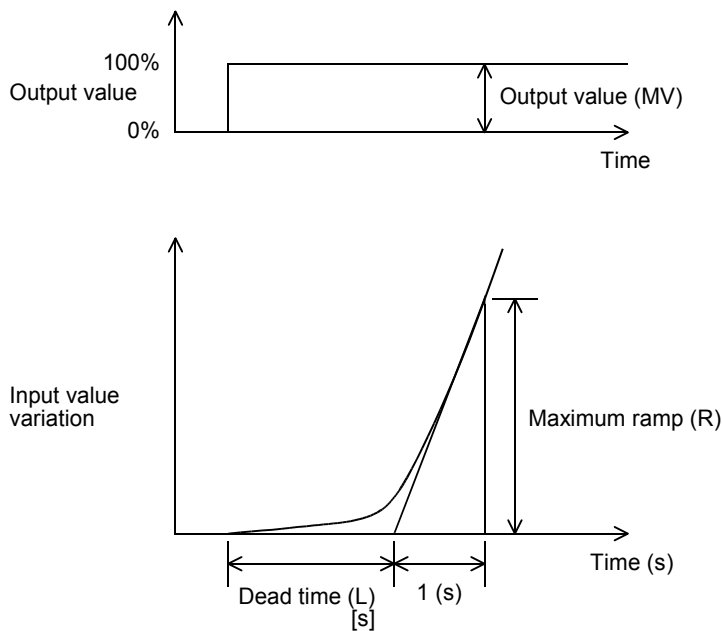

Operation characteristics and three constants

Control type	Proportional gain (KP) [%]	Integral time (Ti) [×100ms]	Differential time (TD) [×10ms]
Only proportional control (P operation)	$\frac{1}{RL} \times \text{Output value} \times 100$ (MV)	—	—
PI control (PI operation)	$\frac{0.9}{RL} \times \text{Output value} \times 100$ (MV)	33 L	—
PID control (PID operation)	$\frac{1.2}{RL} \times \text{Output value} \times 100$ (MV)	20 L	50 L

4.3 Cautions on Auto-Tuning Execution

1. Countermeasures with in the program when the input value (PV) does not change

When the input value (PV) does not change normally due to factors such as wire breakage in an analog input line, auto-tuning is not finished.

Detect and avoid such occurrences by introducing a sequence to monitor the input value or the elapsed time from the start of auto-tuning.

5. Example of Practical Programs (for Step Response Method)

The following is an example of a program for the operation application system shown below.

5.1 Example: System and operation

System configuration

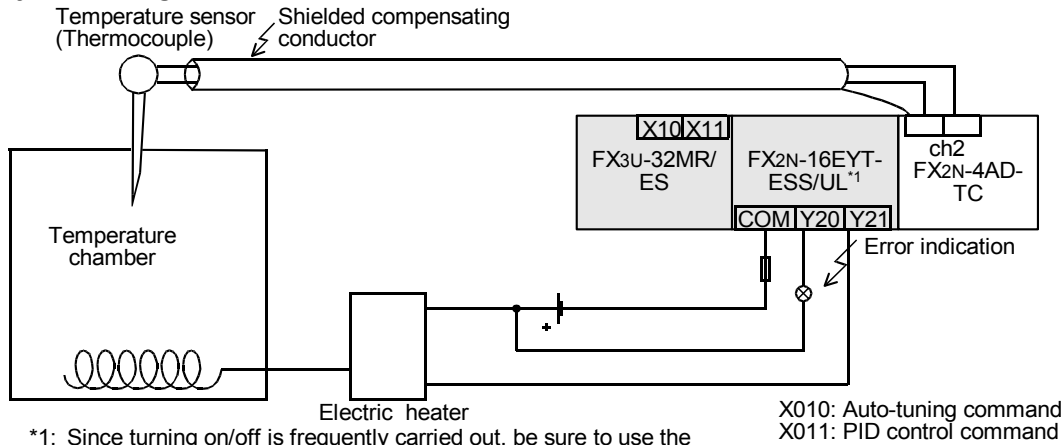

*1: Since turning on/off is frequently carried out, be sure to use the transistor outputs.

Setting contents

Item		During auto-tuning	During PID control	
Target value	(S1)	500 (+50°C)	500 (+50°C)	
Parameters	Sampling time (Ts)	(S3)	3000 ms	
	Input filter (α)	(S3) +2	70%	
	Differential gain (KD)	(S3) +5	0%	
	Output value upper limit	(S3) +22	2000 (2 seconds)	
	Output value lower limit	(S3) +23	0	
	Operation direction (ACT)	Input variation alarm	bit 1 of (S3) +1	Not provided
		Output variation alarm	bit 2 of (S3) +1	Not provided
Output value upper/lower limit setting		bit 5 of (S3) +1	Provided	
Output value	(D)	1800	According to operation	

1. Operation of the electric heater

1) During PID control

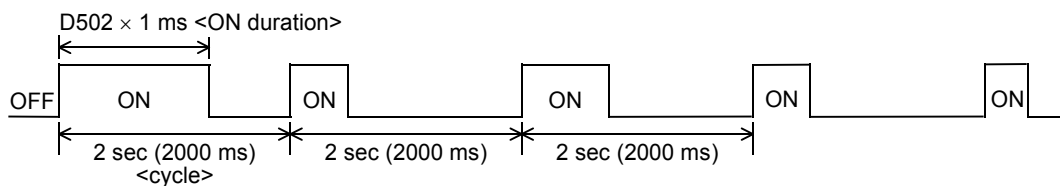

2) During auto-tuning: When the output is 90% of the maximum output

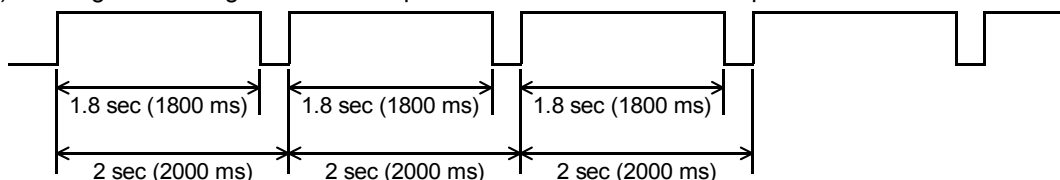

5.2 Program example of auto-tuning (step response method) and PID control

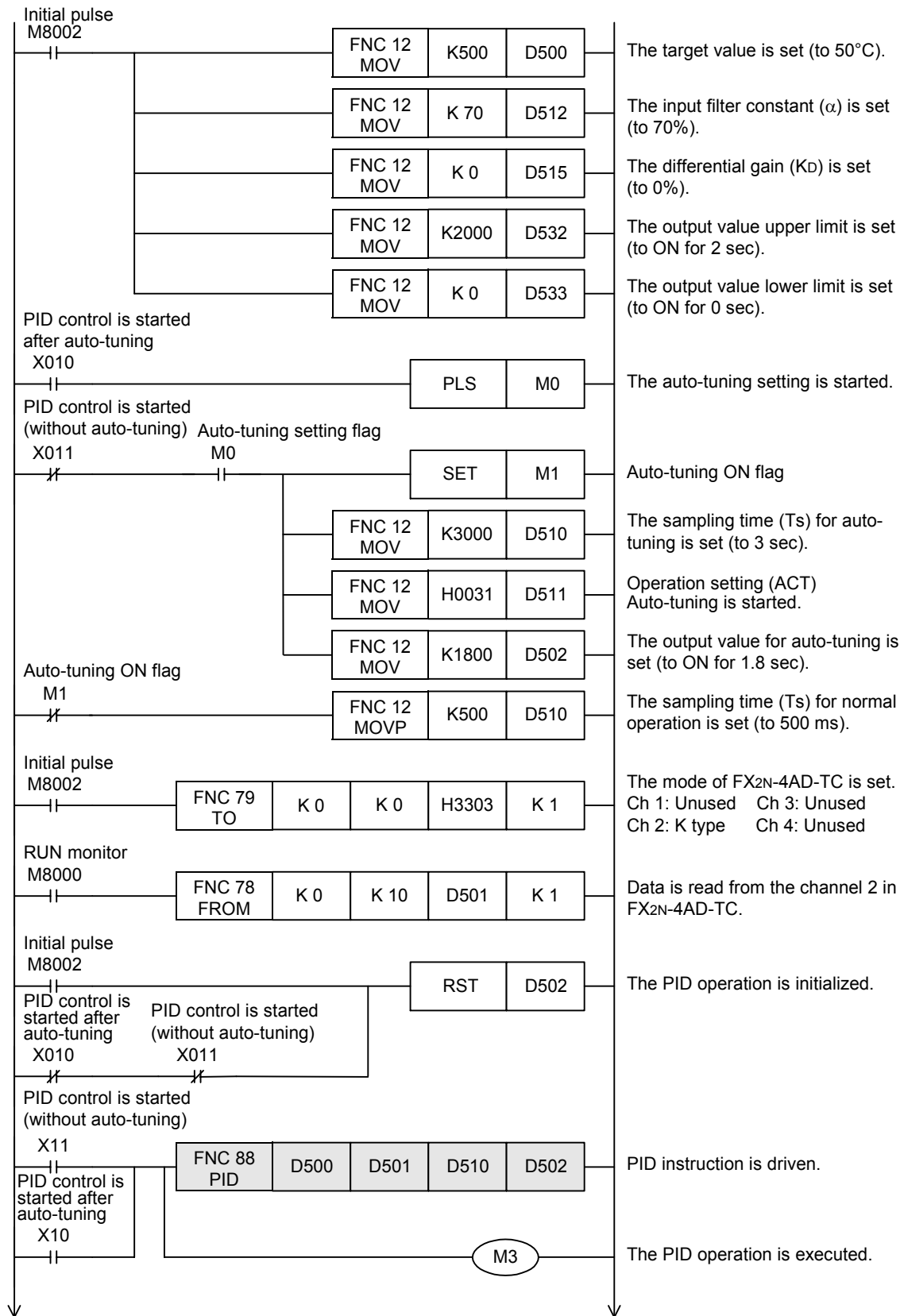

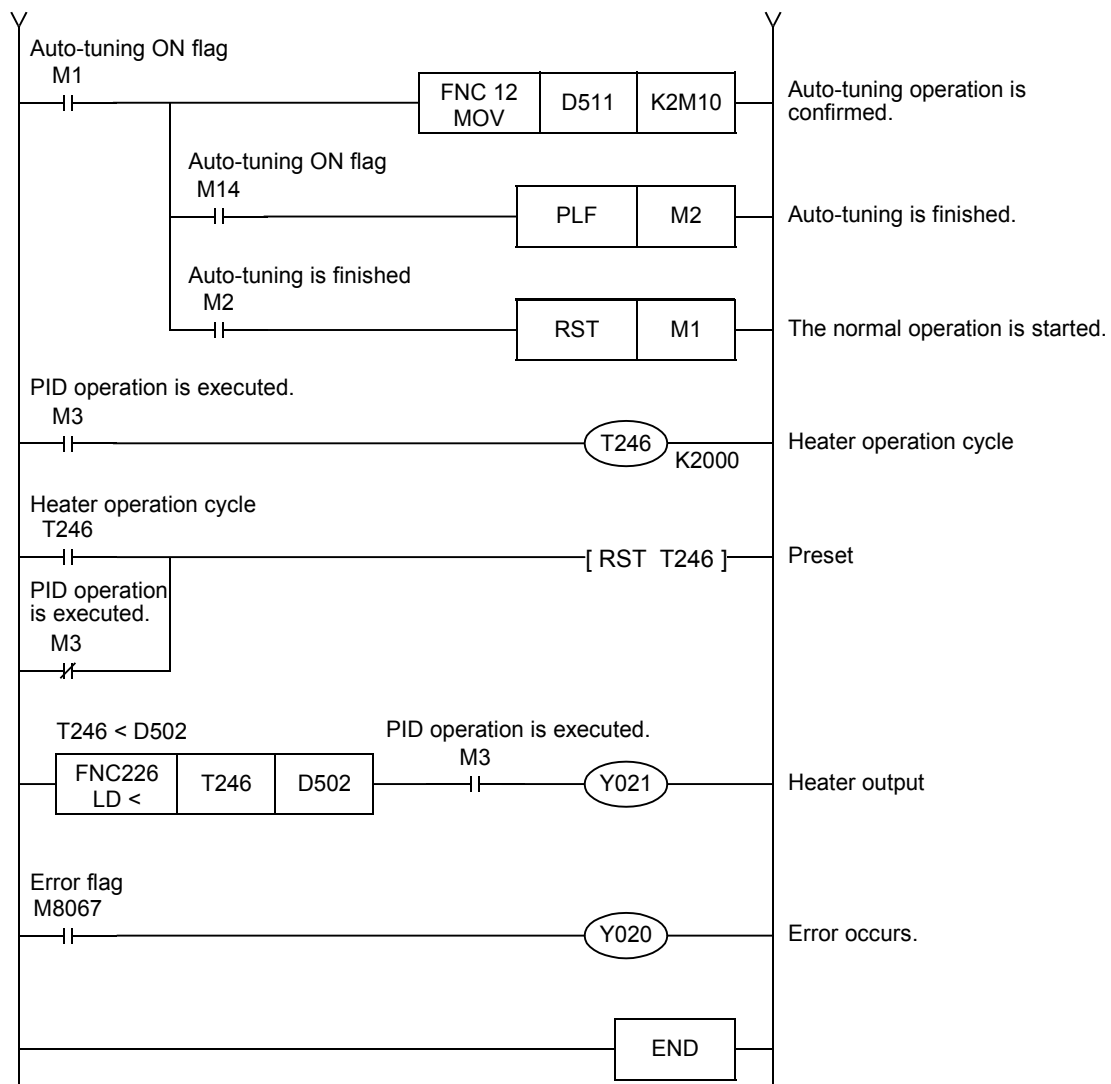

K
 FX3U-4AD-FNK-ADP
L
 FX3U-4AD-TC-ADP
M
 PID Instruction (FNC 88)

5.3 Program example of auto-tuning (step response method)

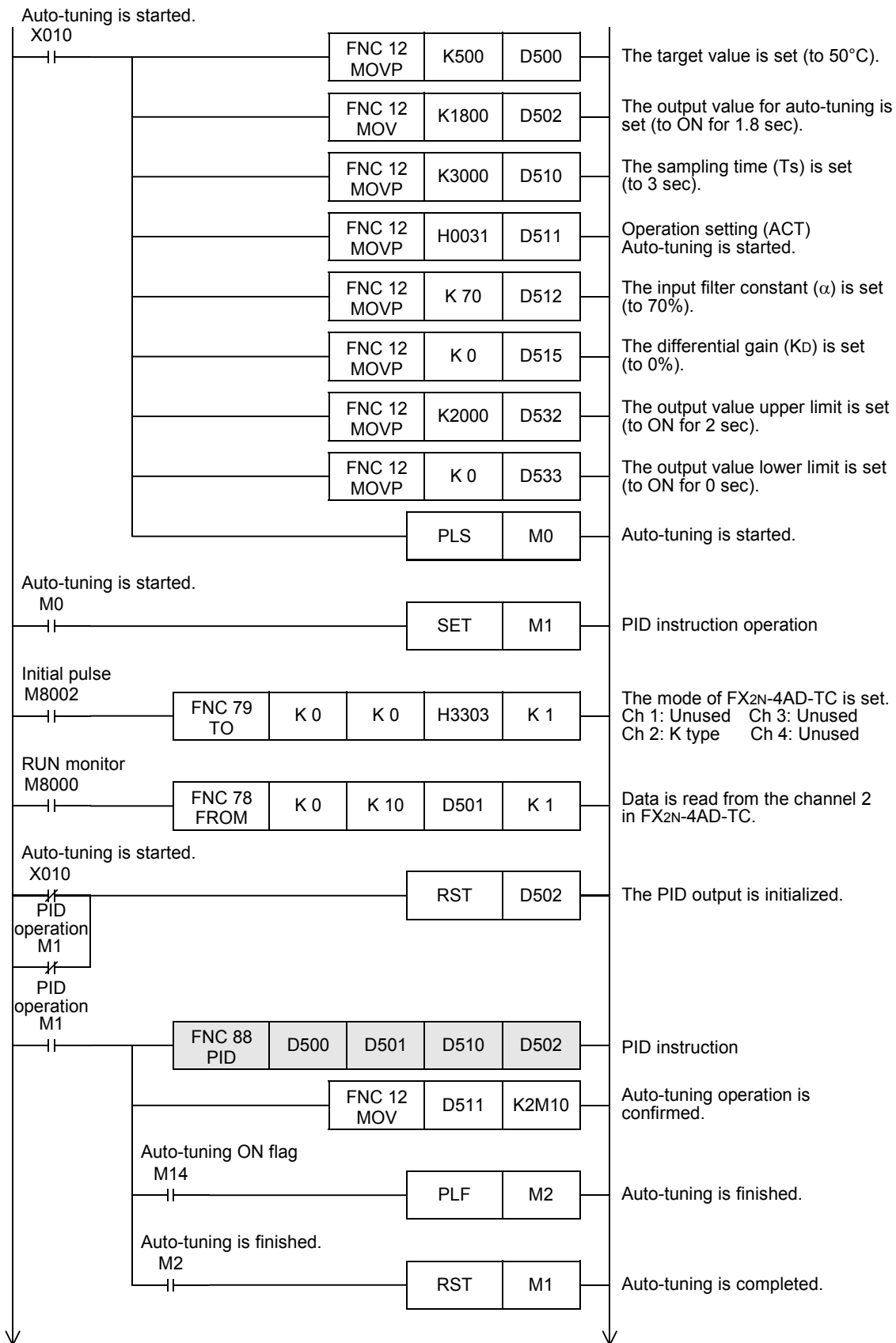

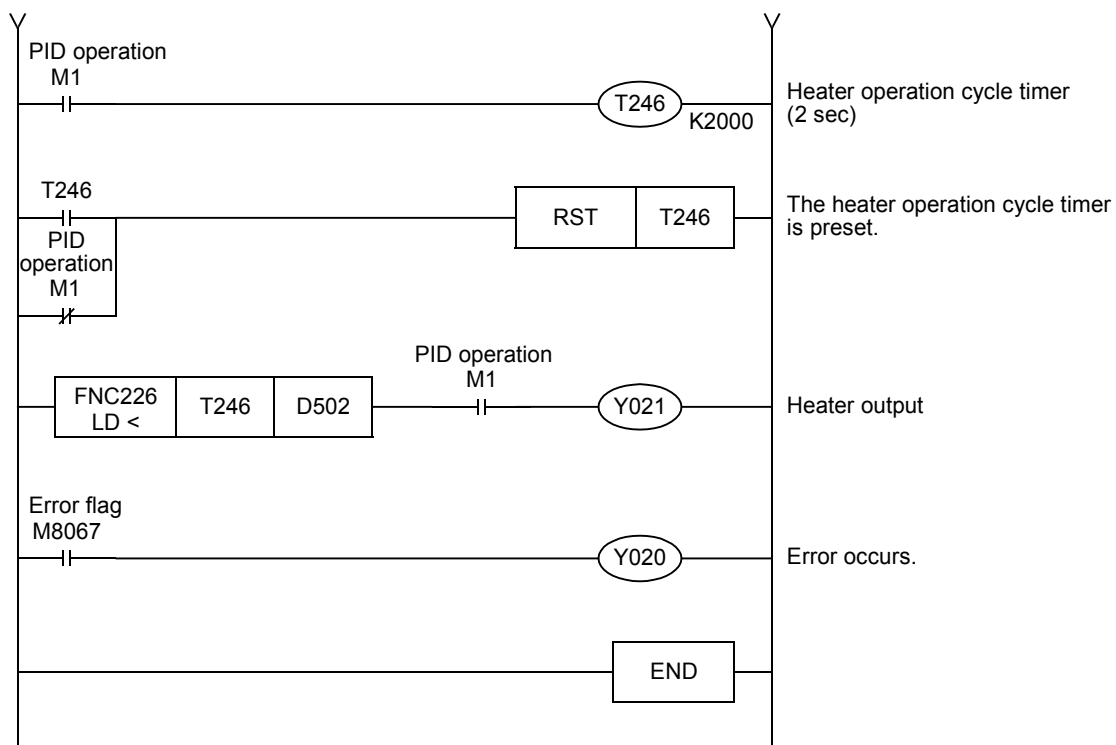

6. Troubleshooting

6.1 Error Codes

When an error occurs in the set value of a control parameter or the data acquired during the PID operation, the operation error flag M8067 turns ON, and a corresponding error code is stored in D8067.

Error code	Error description	Action
6730	Incorrect sampling time (TS) ($TS \leq 0$)	<PID operation is stopped.> A data error has occurred in the set value in a control parameter or in the middle of PID operation. Check the parameters.
6732	Incorrect input filter constant (α) ($\alpha < 0$ or $100 \leq \alpha$)	
6733	Incorrect proportional gain (KP) ($KP < 0$)	
6734	Incorrect integral time (TI) ($TI < 0$)	
6735	Incorrect derivative gain (KD) ($KD < 0$ or $201 \leq KD$)	
6736	Incorrect derivative time (TD) ($TD < 0$)	
6740	Sampling time (TS) \leq Operation cycle	<Auto-tuning is continued.> The operation is continued in the condition "sampling time (TS) = cyclic time (operation cycle)."
6742	Variation of measured value exceeds limit. ($\Delta PV < -32768$ or $+32767 < \Delta PV$)	<PID operation is continued.> The operation is continued with each parameter set to the maximum or minimum value.
6743	Deviation exceeds limit. ($EV < -32768$ or $+32767 < EV$)	
6744	Integral result exceeds limit. (Out of range from -32768 to $+32767$)	
6745	Derivative value exceeds limit due to derivative gain (KD).	
6746	Derivative result exceeds limit. (Out of range from -32768 to $+32767$)	
6747	PID operation result exceeds limit. (Out of range from -32768 to $+32767$)	
6748	PID output upper limit set value < PID output lower limit set value	<Output upper limit value and output lower limit value are exchanged for each other. → PID operation is continued.> Check whether the target settings are correct.
6749	Abnormal PID input variation alarm set value or output variation alarm set value (Set value < 0)	<Alarm output is not given. → PID operation is continued.> Check whether the target settings are correct.
6750	<Step response method> Improper auto-tuning result	<Auto-tuning is finished. → PID operation is started.> <ul style="list-style-type: none"> The deviation at start of auto-tuning is 150 or less. The deviation at end of auto-tuning is 1/3 or more of the deviation at start of auto-tuning. Confirm the measured value and target value, and then execute auto-tuning again.
6751	<Step response method> Auto-tuning operation direction mismatch	<Auto-tuning is forced to finish. → PID operation does not started.> The operation direction estimated from the measured value at the start of auto-tuning was different from the actual operation direction of the output during auto-tuning. Correct the relationship among the target value, output value for auto-tuning and measured value, and then execute auto-tuning again.

Error code	Error description	Action
6752	<Step response method> Improper auto-tuning operation	<Auto-tuning is finished. → PID operation is not started.> Because the set value fluctuated during auto-tuning, auto-tuning was not executed correctly. Set the sampling time to a value larger than the output change cycle, or set a larger value to the input filter constant. After changing the setting, execute auto-tuning again.
6753	<Limit cycle method> Abnormal output set value for auto-tuning [ULV (upper limit) ≤ LLV (lower limit)]	<Auto-tuning is forcibly finished. → PID operation is not started.> Check whether the target settings are correct.
6754	<Limit cycle method> Abnormal PV threshold (hysteresis) set value for auto-tuning (SHPV < 0)	<Auto-tuning is forcibly finished. → PID operation is not started.> Verify that devices occupied by PID instruction are not overwritten in the program.
6755	<Limit cycle method> Abnormal auto-tuning transfer status (Data of device controlling transfer status is abnormally overwritten.)	<Auto-tuning is forcibly finished. → PID operation is not started.> The auto-tuning time is too long. Increase the difference (ULV - LLV) between the upper limit and the lower limit of the output value for auto-tuning, set a smaller value to the input filter constant (α), or set a smaller value to the PV threshold (SHPV) for auto-tuning, and then check whether the result is improved.
6756	<Limit cycle method> Abnormal result due to excessive auto-tuning measurement time ($\tau_{on} > \tau$, $\tau_{on} < 0$, $\tau < 0$)	<Auto-tuning is finished (KP = 32767). → PID operation is started.> The variation of the measured value (PV) is small compared with the output value. Multiply the measured value (PV) by "10" so that the variation of the measured value will increase during auto-tuning.
6757	<Limit cycle method> Auto-tuning result exceeds proportional gain. (KP = Out of range from 0 to 32767)	<Auto-tuning is finished (KP = 32767). → PID operation is started.> The auto-tuning time is too long. Increase the difference (ULV - LLV) between the upper limit and the lower limit of the output value for auto-tuning, set a smaller value to the input filter constant (α), or set a smaller value to the PV threshold (SHPV) for auto-tuning, and then check whether the result is improved.
6758	<Limit cycle method> Auto-tuning result exceeds integral time. (TI = Out of range from 0 to 32767)	<Auto-tuning is finished (KP = 32767). → PID operation is started.> The auto-tuning time is too long. Increase the difference (ULV - LLV) between the upper limit and the lower limit of the output value for auto-tuning, set a smaller value to the input filter constant (α), or set a smaller value to the PV threshold (SHPV) for auto-tuning, and then check whether the result is improved.
6759	<Limit cycle method> Auto-tuning result exceeds derivative time. (TD = Out of range from 0 to 32767)	<Auto-tuning is finished (KP = 32767). → PID operation is started.> The auto-tuning time is too long. Increase the difference (ULV - LLV) between the upper limit and the lower limit of the output value for auto-tuning, set a smaller value to the input filter constant (α), or set a smaller value to the PV threshold (SHPV) for auto-tuning, and then check whether the result is improved.

Caution

With regard to the measured value (PV) in PID, normal measurement data should be read before PID operation begins.
 Especially when the PID operation is executed to the input value in an analog input block, pay attention to the conversion time.

MEMO

Warranty

Please confirm the following product warranty details before using this product.

1. Gratis Warranty Term and Gratis Warranty Range

If any faults or defects (hereinafter "Failure") found to be the responsibility of Mitsubishi occurs during use of the product within the gratis warranty term, the product shall be repaired at no cost via the sales representative or Mitsubishi Service Company. However, if repairs are required onsite at domestic or overseas location, expenses to send an engineer will be solely at the customer's discretion. Mitsubishi shall not be held responsible for any re-commissioning, maintenance, or testing on-site that involves replacement of the failed module.

[Gratis Warranty Term]

The gratis warranty term of the product shall be for one year after the date of purchase or delivery to a designated place. Note that after manufacture and shipment from Mitsubishi, the maximum distribution period shall be six (6) months, and the longest gratis warranty term after manufacturing shall be eighteen (18) months. The gratis warranty term of repair parts shall not exceed the gratis warranty term before repairs.

[Gratis Warranty Range]

- 1) The range shall be limited to normal use within the usage state, usage methods and usage environment, etc., which follow the conditions and precautions, etc., given in the instruction manual, user's manual and caution labels on the product.
- 2) Even within the gratis warranty term, repairs shall be charged for in the following cases.
 - a) Failure occurring from inappropriate storage or handling, carelessness or negligence by the user. Failure caused by the user's hardware or software design.
 - b) Failure caused by unapproved modifications, etc., to the product by the user.
 - c) When the Mitsubishi product is assembled into a user's device, Failure that could have been avoided if functions or structures, judged as necessary in the legal safety measures the user's device is subject to or as necessary by industry standards, had been provided.
 - d) Failure that could have been avoided if consumable parts (battery, backlight, fuse, etc.) designated in the instruction manual had been correctly serviced or replaced.
 - e) Relay failure or output contact failure caused by usage beyond the specified Life of contact (cycles).
 - f) Failure caused by external irresistible forces such as fires or abnormal voltages, and failure caused by force majeure such as earthquakes, lightning, wind and water damage.
 - g) Failure caused by reasons unpredictable by scientific technology standards at time of shipment from Mitsubishi.
 - h) Any other failure found not to be the responsibility of Mitsubishi or that admitted not to be so by the user.

2. Onerous repair term after discontinuation of production

- 1) Mitsubishi shall accept onerous product repairs for seven (7) years after production of the product is discontinued. Discontinuation of production shall be notified with Mitsubishi Technical Bulletins, etc.
- 2) Product supply (including repair parts) is not available after production is discontinued.

3. Overseas service

Overseas, repairs shall be accepted by Mitsubishi's local overseas FA Center. Note that the repair conditions at each FA Center may differ.

4. Exclusion of loss in opportunity and secondary loss from warranty liability

Regardless of the gratis warranty term, Mitsubishi shall not be liable for compensation of damages caused by any cause found not to be the responsibility of Mitsubishi, loss in opportunity, lost profits incurred to the user or third person by Failures of Mitsubishi products, special damages and secondary damages whether foreseeable or not, compensation for accidents, and compensation for damages to products other than Mitsubishi products, replacement by the user, maintenance of on-site equipment, start-up test run and other tasks.

5. Changes in product specifications

The specifications given in the catalogs, manuals or technical documents are subject to change without prior notice.

6. Product application

- 1) In using the Mitsubishi MELSEC programmable logic controller, the usage conditions shall be that the application will not lead to a major accident even if any problem or fault should occur in the programmable logic controller device, and that backup and fail-safe functions are systematically provided outside of the device for any problem or fault.
- 2) The Mitsubishi programmable logic controller has been designed and manufactured for applications in general industries, etc. Thus, applications in which the public could be affected such as in nuclear power plants and other power plants operated by respective power companies, and applications in which a special quality assurance system is required, such as for Railway companies or Public service purposes shall be excluded from the programmable logic controller applications. In addition, applications in which human life or property that could be greatly affected, such as in aircraft, medical applications, incineration and fuel devices, manned transportation, equipment for recreation and amusement, and safety devices, shall also be excluded from the programmable logic controller range of applications. However, in certain cases, some applications may be possible, providing the user consults their local Mitsubishi representative outlining the special requirements of the project, and providing that all parties concerned agree to the special circumstances, solely at the users discretion.

Revised History

Date	Revision	Description
7/2005	A	First Edition
2/2006	B	<ul style="list-style-type: none"> FX3U-4AD is added to B. FX3U-4DA is inserted to D. Adding and revising the other descriptions.
3/2006	C	<ul style="list-style-type: none"> B-8 page, 2.2 The Power Supply Specification for the FX3U-4AD, regarding the A/D conversion circuit drive power: Revised from [24V DC \pm10%, 80mA] to [24VDC \pm10%, 90mA]
3/2007	D	<ul style="list-style-type: none"> JIS (Japanese Industrial Standards) for temperature sensors are added Clerical error correction
12/2007	E	<ul style="list-style-type: none"> FX3UC (D, DSS) Series PLC added FX3U-4AD-PTW-ADP is inserted to G Clerical error correction
11/2008	F	<ul style="list-style-type: none"> FX3G Series PLC added FX3G-2AD-BD is added to D. FX3G-1DA-BD is added to G. FX3U-4AD-PNK-ADP is added to H. Adding and revising the other descriptions.
6/2009	G	<ul style="list-style-type: none"> FX3U-3A-ADP is added to H. Explanation corrections for manufacture's serial number. Adding and revising the other descriptions.
8/2010	H	<ul style="list-style-type: none"> Supports the under-scale detection function of the FX3U-4AD-ADP and FX3U-3A-ADP. FX3U-4LC is added. Explanation corrections for the manufacture's serial number. Addition and revision of other descriptions. Clerical error correction

FX3G/FX3U/FX3UC SERIES PROGRAMMABLE CONTROLLERS

USER'S MANUAL

Analog Control Edition



HEAD OFFICE: TOKYO BUILDING, 2-7-3 MARUNOUCHI, CHIYODA-KU, TOKYO 100-8310, JAPAN
HIMEJI WORKS: 840, CHIYODA CHO, HIMEJI, JAPAN

MODEL	FX3U-U-ANALOG-E
MODEL CODE	09R619

HEADQUARTERS

MITSUBISHI ELECTRIC EUROPE B.V. **EUROPE**
 German Branch
 Gothaer Straße 8
D-40880 Ratingen
 Phone: +49 (0)2102 / 486-0
 Fax: +49 (0)2102 / 486-1120

MITSUBISHI ELECTRIC EUROPE B.V. **CZECH REPUBLIC**
 Czech Branch
 Avenir Business Park, Radlická 714/113a
CZ-158 00 Praha 5
 Phone: +420 - 251 551 470
 Fax: +420 - 251-551-471

MITSUBISHI ELECTRIC EUROPE B.V. **FRANCE**
 French Branch
 25, Boulevard des Bouvets
F-92741 Nanterre Cedex
 Phone: +33 (0)1 / 55 68 55 68
 Fax: +33 (0)1 / 55 68 57 57

MITSUBISHI ELECTRIC EUROPE B.V. **IRELAND**
 Irish Branch
 Westgate Business Park, Ballymount
IRL-Dublin 24
 Phone: +353 (0)1 4198800
 Fax: +353 (0)1 4198890

MITSUBISHI ELECTRIC EUROPE B.V. **ITALY**
 Italian Branch
 Viale Colleoni 7
I-20041 Agrate Brianza (MB)
 Phone: +39 039 / 60 53 1
 Fax: +39 039 / 60 53 312

MITSUBISHI ELECTRIC EUROPE B.V. **POLAND**
 Poland Branch
 Krakowska 50
PL-32-083 Balice
 Phone: +48 (0)12 / 630 47 00
 Fax: +48 (0)12 / 630 47 01

MITSUBISHI ELECTRIC EUROPE B.V. **SPAIN**
 Spanish Branch
 Carretera de Rubí 76-80
E-08190 Sant Cugat del Vallés (Barcelona)
 Phone: 902 131121 // +34 935653131
 Fax: +34 935891579

MITSUBISHI ELECTRIC EUROPE B.V. **UK**
 UK Branch
 Travellers Lane
UK-Hatfield, Herts. AL10 8XB
 Phone: +44 (0)1707 / 27 61 00
 Fax: +44 (0)1707 / 27 86 95

MITSUBISHI ELECTRIC CORPORATION **JAPAN**
 Office Tower "Z" 14 F
 8-12, 1 chome, Harumi Chuo-Ku
Tokyo 104-6212
 Phone: +81 3 622 160 60
 Fax: +81 3 622 160 75

MITSUBISHI ELECTRIC AUTOMATION, Inc. **USA**
 500 Corporate Woods Parkway
Vernon Hills, IL 60061
 Phone: +1 847 478 21 00
 Fax: +1 847 478 22 53

EUROPEAN REPRESENTATIVES

GEVA **AUSTRIA**
 Wiener Straße 89
AT-2500 Baden
 Phone: +43 (0)2252 / 85 55 20
 Fax: +43 (0)2252 / 488 60

TEHNIKON **BELARUS**
 Oktyabrskaya 16/5, Off. 703-711
BY-220030 Minsk
 Phone: +375 (0)17 / 210 46 26
 Fax: +375 (0)17 / 210 46 26

ESCO DRIVES & AUTOMATION **BELGIUM**
 Culliganlaan 3
BE-1831 Diegem
 Phone: +32 (0)2 / 717 64 30
 Fax: +32 (0)2 / 717 64 31

Koning & Hartman b.v. **BELGIUM**
 Woluwelaan 31
BE-1800 Vilvoorde
 Phone: +32 (0)2 / 257 02 40
 Fax: +32 (0)2 / 257 02 49

INEA BH d.o.o. **BOSNIA AND HERZEGOVINA**
 Aleja Lipa 56
BA-71000 Sarajevo
 Phone: +387 (0)33 / 921 164
 Fax: +387 (0)33 / 524 539

AKHNATON **BULGARIA**
 4 Andrej Ljapchev Blvd. Pb 21
BG-1756 Sofia
 Phone: +359 (0)2 / 817 6004
 Fax: +359 (0)2 / 97 44 06 1

INEA CR d.o.o. **CROATIA**
 Losinjiska 4 a
HR-10000 Zagreb
 Phone: +385 (0)1 / 36 940 -01 / -02 / -03
 Fax: +385 (0)1 / 36 940 -03

AutoCont C.S. s.r.o. **CZECH REPUBLIC**
 Technologická 374/6
CZ-708 00 Ostrava-Pustkovce
 Phone: +420 595 691 150
 Fax: +420 595 691 199

B:ELECTRIC, s.r.o. **CZECH REPUBLIC**
 Mladoboleslavská 812
CZ-197 00 Praha 19 - Kbely
 Phone: +420 286 850 848, +420 724 317 975
 Fax: +420 286 850 850

Beijer Electronics A/S **DENMARK**
 Lykkegårdsvej 17
DK-4000 Roskilde
 Phone: +45 (0)46 / 75 76 66
 Fax: +45 (0)46 / 75 56 26

Beijer Electronics Eesti OÜ **ESTONIA**
 Pärnu mnt.160i
EE-11317 Tallinn
 Phone: +372 (0)6 / 51 81 40
 Fax: +372 (0)6 / 51 81 49

Beijer Electronics OY **FINLAND**
 Peltoie 37
FIN-28400 Ulvila
 Phone: +358 (0)207 / 463 540
 Fax: +358 (0)207 / 463 541

UTECO A.B.E.E. **GREECE**
 5, Mavrogenous Str.
GR-18542 Piraeus
 Phone: +30 211 / 1206 900
 Fax: +30 211 / 1206 999

MELTRADE Kft. **HUNGARY**
 Fertő utca 14.
HU-1107 Budapest
 Phone: +36 (0)1 / 431-9726
 Fax: +36 (0)1 / 431-9727

Beijer Electronics SIA **LATVIA**
 Rītausmas iela 23
LV-1058 Riga
 Phone: +371 (0)784 / 2280
 Fax: +371 (0)784 / 2281

Beijer Electronics UAB **LITHUANIA**
 Savanorių Pr. 187
LT-02300 Vilnius
 Phone: +370 (0)5 / 232 3101
 Fax: +370 (0)5 / 232 2980

EUROPEAN REPRESENTATIVES

ALFATRADE Ltd. **MALTA**
 99, Paola Hill
Malta- Paola PLA 1702
 Phone: +356 (0)21 / 697 816
 Fax: +356 (0)21 / 697 817

INTEHSIS srl **MOLDOVA**
 bld. Traian 23/1
MD-2060 Kishinev
 Phone: +373 (0)22 / 66 4242
 Fax: +373 (0)22 / 66 4280

HIFLEX AUTOM.TECHNIEK B.V. **NETHERLANDS**
 Wolweverstraat 22
NL-2984 CD Ridderkerk
 Phone: +31 (0)180 - 46 60 04
 Fax: +31 (0)180 - 44 23 55

Koning & Hartman b.v. **NETHERLANDS**
 Haarlbergweg 21-23
NL-1101 CH Amsterdam
 Phone: +31 (0)20 / 587 76 00
 Fax: +31 (0)20 / 587 76 05

Beijer Electronics AS **NORWAY**
 Postboks 487
NO-3002 Drammen
 Phone: +47 (0)32 / 24 30 00
 Fax: +47 (0)32 / 84 85 77

Sirius Trading & Services srl **ROMANIA**
 Aleea Lacul Morii Nr. 3
RO-060841 Bucuresti, Sector 6
 Phone: +40 (0)21 / 430 40 06
 Fax: +40 (0)21 / 430 40 02

Craft Con. & Engineering d.o.o. **SERBIA**
 Bulevar Svetog Cara Konstantina 80-86
SER-18106 Nis
 Phone: +381 (0)18 / 292-24-4/5
 Fax: +381 (0)18 / 292-24-4/5

INEA SR d.o.o. **SERBIA**
 Izletnicka 10
SER-113000 Smederevo
 Phone: +381 (0)26 / 617 163
 Fax: +381 (0)26 / 617 163

AutoCont Control s.r.o. **SLOVAKIA**
 Radlinského 47
SK-02601 Dolny Kubin
 Phone: +421 (0)43 / 5868210
 Fax: +421 (0)43 / 5868210

CS MTrade Slovensko, s.r.o. **SLOVAKIA**
 Vajanskeho 58
SK-92101 Piestany
 Phone: +421 (0)33 / 7742 760
 Fax: +421 (0)33 / 7735 144

INEA d.o.o. **SLOVENIA**
 Stegne 11
SI-1000 Ljubljana
 Phone: +386 (0)1 / 513 8100
 Fax: +386 (0)1 / 513 8170

Beijer Electronics AB **SWEDEN**
 Box 426
SE-20124 Malmö
 Phone: +46 (0)40 / 35 86 00
 Fax: +46 (0)40 / 93 23 01

Omni Ray AG **SWITZERLAND**
 Im Schörl 5
CH-8600 Dübendorf
 Phone: +41 (0)44 / 802 28 80
 Fax: +41 (0)44 / 802 28 28

GTS **TURKEY**
 Bayraktar Bulvari Nutuk Sok. No:5
TR-34775 Yukarı Dudullu-Ümraniye-İSTANBUL
 Phone: +90 (0)216 526 39 90
 Fax: +90 (0)216 526 3995

CSC Automation Ltd. **UKRAINE**
 4-B, M. Raskovoyi St.
UA-02660 Kiev
 Phone: +380 (0)44 / 494 33 55
 Fax: +380 (0)44 / 494-33-66

EURASIAN REPRESENTATIVES

Kazpromautomatiks Ltd. **KAZAKHSTAN**
 Mustafina Str. 7/2
KAZ-470046 Karaganda
 Phone: +7 7212 / 50 11 50
 Fax: +7 7212 / 50 11 50

MIDDLE EAST REPRESENTATIVES

TEXEL ELECTRONICS Ltd. **ISRAEL**
 2 Ha'umanut, P.O.B. 6272
IL-42160 Netanya
 Phone: +972 (0)9 / 863 39 80
 Fax: +972 (0)9 / 885 24 30

CEG INTERNATIONAL **LEBANON**
 Cebaco Center/Block A Autostrade DORA
Lebanon - Beirut
 Phone: +961 (0)1 / 240 430
 Fax: +961 (0)1 / 240 438

AFRICAN REPRESENTATIVE

CBI Ltd. **SOUTH AFRICA**
 Private Bag 2016
ZA-1600 Isando
 Phone: +27 (0)11 / 977 0770
 Fax: +27 (0)11 / 977 0761