

Miniature Interlock Switches

HS5D

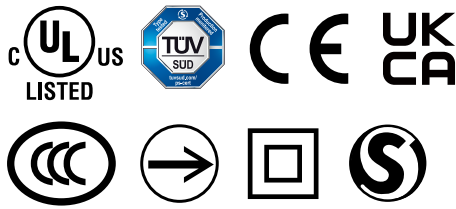

Head removal detection for safer performance.



Note: Contact IDEC for KOSHA approved model.

- See website for details on approvals and standards.

Head Removal Detection Function

All HS5D models are equipped with “Head Removal Detection Function.” When the head is removed, such as when the head is rotated, the main circuit (11-12) turns OFF.

HS5D-12 (example)

When the actuator is removed or inserted, the operation of the main circuits (11-12, 21-22) are the same. However, when the head is removed, disparity is detected (11-12: OFF, 21-22: ON). The disparity of the contacts detects the removal of the head.

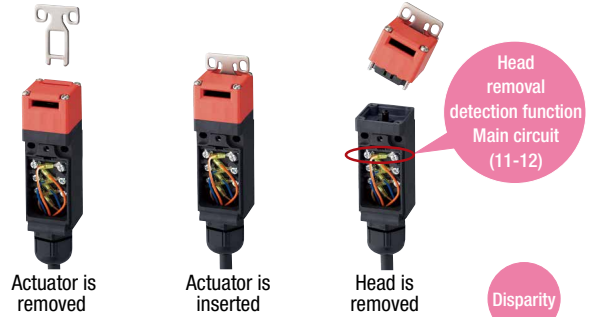

HS5D-12

	When actuator is removed	When actuator is inserted	When head is removed
Main circuit (NC) $\ominus 11, 12$	OFF	ON	OFF
Main circuit (NC) $\ominus 21, 22$	OFF	ON	ON

Note: Head removal detection function is not a direct opening action mechanism.

Existing Interlock Switches

	When actuator is removed	When actuator is inserted	When head is removed
Main circuit (NC) $\ominus 3, 4$	OFF	ON	ON
Monitor circuit (NC) $\ominus 1, 2$	OFF	ON	ON

Small size with 3 contacts

- 3 contact types with dual enabling contacts and a monitor contact are available.
- Compact size. Can be installed in narrow spaces.



The head orientation can be rotated, allowing 8 different actuator entries.

Double insulation structure eliminates the need for grounding.

Degree of protection (contacts): IP67 (IEC60529)

NC contacts with direct opening action (IEC/EN60947-5-1)

HS5D Miniature Interlock Switches



Specifications

Applicable Standards	EN ISO14119 IEC60947-5-1 EN60947-5-1 (TÜV approved) GS-ET-15 (TÜV approved) UL508 (UL listed) CSA C22.2 No. 14 (c-UL listed) GB14048.5 (CCC approved) KS C IEC60947-5-1/S1-G-1/S2-E-4 (KOSHA approved) IEC60204-1/EN60204-1 (applicable standards for use)
Type and Coded Level	Type 2 low level coded interlocking device (ISO 14119)
Operating Temperature	-30 to +70°C (no freezing)
Relative Humidity	45 to 85% (no condensation)
Storage Temperature	-40 to +80°C (no freezing)
Pollution Degree	3
Impulse Withstand Voltage	4 kV
Contact Resistance	50 mΩ maximum (initial value)
Insulation Resistance (500V DC megger)	Between live and dead metal parts: 100 MΩ minimum Between terminals of different poles: 100 MΩ minimum
Electric Shock Protection Class	Class II (IEC61140)
Degree of Protection	IP67 (IEC60529)
Shock Resistance	Damage limits: 1000 m/s ²
Vibration Resistance	Operating extremes: 10 to 55 Hz, amplitude 0.5 mm Damage limits: 30 Hz, amplitude 1.5 mm
Actuator Operating Speed	0.05 to 1.0 m/s
Direct Opening Travel	10 mm minimum
Direct Opening Force	50N minimum
Operating Frequency	900 operations per hour
Mechanical Durability	1,000,000 operations minimum (GS-ET-15)
Electrical Durability	100,000 operations minimum (AC-12 250V, 6A) 1,000,000 operations minimum (24V AC/DC, 100 mA) (operation frequency: 900 operations per hour)
Performance of Terminals 11-12 of Removed Head Unit	Mechanical damage limits: 10 operations min. Insulation resistance: 100 MΩ (initial value) Dielectric strength: 1000V, 1 minute (initial value)
Conditional Short-circuit Current	100A (250V) (note)
Weight (approx.)	Plastic head: 80g (HS5D-□□) Metal head: 110g (HS5D-□□Z)

Note: Use a 250V/10A fast-blow fuse as a short-circuit protector.

Contact Ratings

Rated Insulation Voltage (Ui)		300V			
Thermal Current (Ith)		10A			
Rated Voltage (Ue)		30V	125V	250V	
Rated Current (Ie) *	AC	Resistive load (AC-12)	10A	10A	6A
		Inductive Load (AC-15)	10A	5A	3A
	DC	Resistive load (DC-12)	8A	2.2A	1.1A
		Inductive Load (DC-13)	4A	1.1A	0.6A

- Minimum applicable load (reference): 5V AC/DC, 1 mA
(Applicable range may vary with operating conditions and load types.)
- * TÜV rating: AC-15 3A/250V, DC-13 4A/30V

Part No. Development

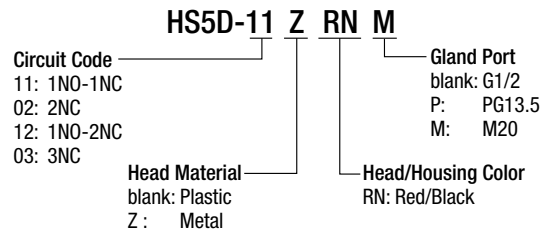

Parts Description

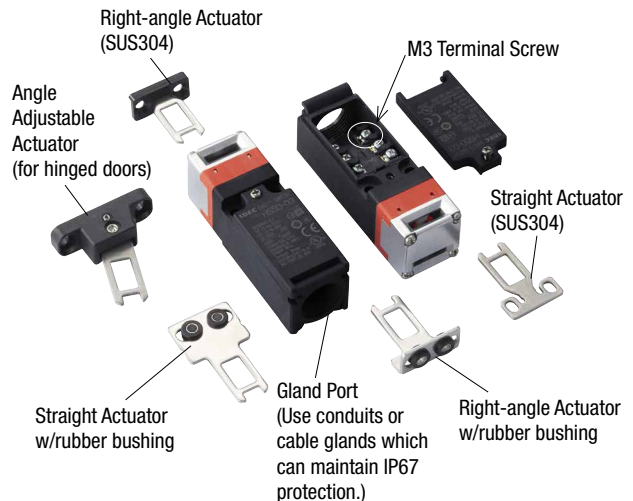

- APEM
- Switches & Pilot Lights
- Control Boxes
- Emergency Stop Switches
- Enabling Switches
- Safety Products
- Explosion Proof
- Terminal Blocks
- Relays & Sockets
- Circuit Protectors
- Power Supplies
- LED Illumination
- Controllers
- Operator Interfaces
- Sensors
- AUTO-ID

- Interlock Switches
- Non-contact Interlock Switches
- Safety Laser Scanners
- Safety Light Curtains
- Safety Modules

HS6B

HS6E

HS5D

HS5L

HS1L

Actuators for HS1/HS5/HS6

Actuators/ Padlock Hasp

HS5D Miniature Interlock Switches

Miniature Safety Interlock Switch

Package Quantity: 1

Contact Configuration	Gland Port Size	Part No.	
		Plastic Head	Metal Head
1NC-1NO Main Circuit ⊖ 11-12 Monitor Circuit ⊖ 23-24	G1/2	HS5D-11RN	HS5D-11ZR
	PG13.5	HS5D-11RNP	HS5D-11ZRNP
	M20	HS5D-11RNM	HS5D-11ZRNM
2NC Main Circuit ⊖ 11-12 Monitor Circuit ⊖ 21-22	G1/2	HS5D-02RN	HS5D-02ZR
	PG13.5	HS5D-02RNP	HS5D-02ZRNP
	M20	HS5D-02RNM	HS5D-02ZRNM
2NC-1NO Main Circuit ⊖ 11-12 Main Circuit ⊖ 21-22 Monitor Circuit ⊖ 33-34	G1/2	HS5D-12RN	HS5D-12ZR
	PG13.5	HS5D-12RNP	HS5D-12ZRNP
	M20	HS5D-12RNM	HS5D-12ZRNM
3NC Main Circuit ⊖ 11-12 Main Circuit ⊖ 21-22 Monitor Circuit ⊖ 31-32	G1/2	HS5D-03RN	HS5D-03ZR
	PG13.5	HS5D-03RNP	HS5D-03ZRNP
	M20	HS5D-03RNM	HS5D-03ZRNM

Actuator

Package Quantity: 1

Name	Part No.
Straight	HS9Z-A51
Straight w/rubber bushings	HS9Z-A51A
Right-angle	HS9Z-A52
Right-angle w/rubber bushings	HS9Z-A52A
Angle Adjustable (vertical/horizontal)	HS9Z-A55

• See E-064 for details on actuators.

Accessories

Package Quantity: 1

Name	Part No.	Remarks
Plug Actuator	HS9Z-A5P	
Door Handle Actuator	Handle Unit	HS9Z-DH5RH For right-hand door.
		HS9Z-DH5LH For left-hand door.
	Switch Cover Unit	HS9Z-DH5C Used for installing the interlock switch inside.
	HS5D Installation Kit	HS9Z-DH5B Used for mounting HS5D.
Sliding Actuator	HS9Z-SH5	
Slide Handle Actuator	HS9Z-EH5L	
Padlock Hasp	HS9Z-PH5	

• See E-071 to E-090 for details on accessories.

Contact Configuration and Operation Chart

Model	Contact Configuration	Contact Operation Chart (reference)	
		0 (Actuator Mounting Reference Position)	
		Approx. 4.6	Approx. 6.7
		Approx. 26.4 (Travel: mm)	
HS6B	HS5D-11* Main Circuit ⊖ 11-12 Monitor Circuit ⊖ 23-24	11-12	23-24
HS6E			
HS5D	HS5D-02* Main Circuit ⊖ 11-12 Monitor Circuit ⊖ 21-22	11-12	21-22
HS5L			
HS1L	HS5D-12* Main Circuit ⊖ 11-12 Main Circuit ⊖ 21-22 Monitor Circuit ⊖ 33-34	11-12	21-22
	HS5D-03* Main Circuit ⊖ 11-12 Main Circuit ⊖ 21-22 Monitor Circuit ⊖ 31-32	11-12	21-22

: Contact ON (closed)
 : Contact OFF (open)

Actuator inserted completely Actuator removed completely

- The operation characteristics shown in the chart above are for the HS9Z-A51. For other actuator types, add 1.3 mm.
- The operation characteristics show the contact status when the actuator enters the entry slot of an interlock switch.

Terminal Arrangement

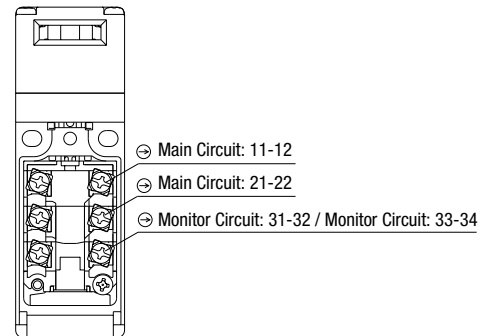

Dimensions and Mounting Hole Layouts

HS5D-□□ZR□ (Metal Head)
With HS9Z-A51 Straight Actuator

RP: Reference mounting position

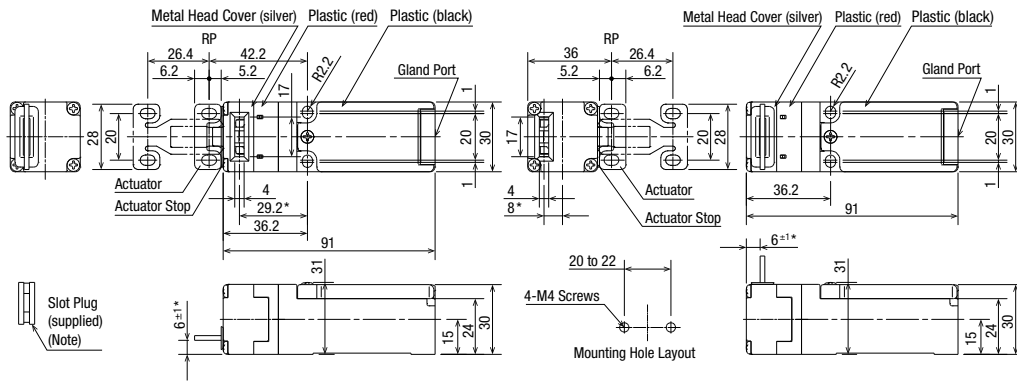

With HS9Z-A52 Right-angle Actuator

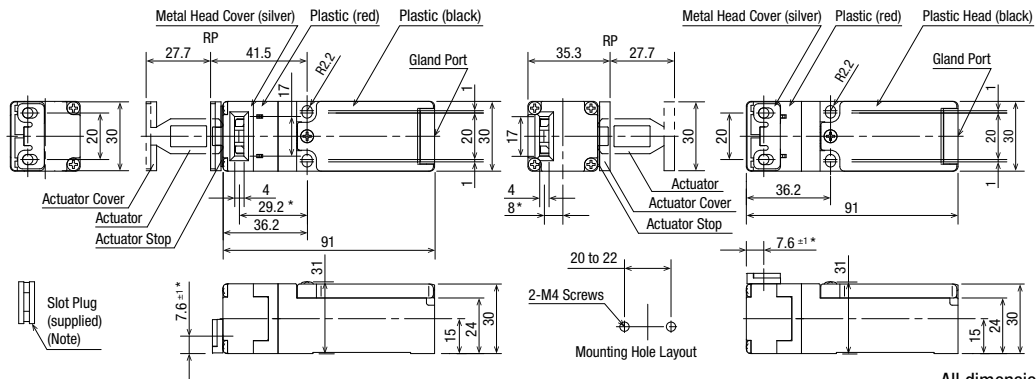

All dimensions in mm.

HS5D-□□RN□ (Plastic Head)
With HS9Z-A51 Straight Actuator

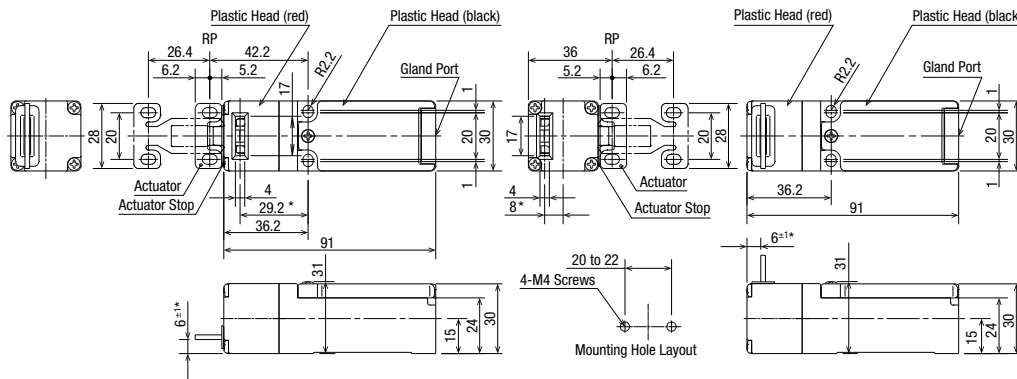

With HS9Z-A52 Right-angle Actuator

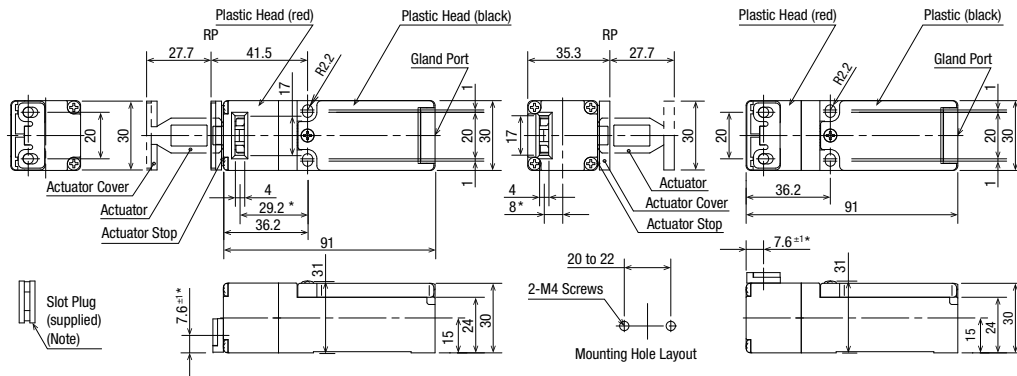

All dimensions in mm.

Note: Plug the unused actuator insertion slot using the slot plug supplied with the safety interlock switch.

- APEM
- Switches & Pilot Lights
- Control Boxes
- Emergency Stop Switches
- Enabling Switches
- Safety Products
- Explosion Proof
- Terminal Blocks
- Relays & Sockets
- Circuit Protectors
- Power Supplies
- LED Illumination
- Controllers
- Operator Interfaces
- Sensors
- AUTO-ID

- Interlock Switches
- Non-contact Interlock Switches
- Safety Laser Scanners
- Safety Light Curtains
- Safety Modules

HS6B

HS6E

HS5D

HS5L

HS1L

Actuators for HS1/HS5/HS6

Actuators/ Padlock Hasp

HS5D Miniature Interlock Switches

 Safety Precautions

- In order to avoid electric shock or fire, turn the power off before installation, removal, wire connection, maintenance, or inspection of the interlock switch.
- If relays are used in the circuit between the interlock switch and the load, use only safety relays, since welded or sticking contacts of standard relays may invalidate the functions of the interlock switch. Perform risk assessment and make up a safety circuit which satisfies the requirements of the safety category.
- For wiring, use wires of a proper size to meet the voltage and current requirements. Tighten the terminal screws to a recommended torque. Improper soldering or failure to tighten the terminal screw may cause overheating and fire.
- Do not install the actuator in the location where a human body may come in contact. Otherwise injury may occur.
- Do not place a PLC in the circuit between the interlock switch and the load. Safety security can be endangered in the event of a malfunction of the PLC.
- Do not disassemble or modify the interlock switch, otherwise a malfunction or an accident may occur.

- HS5D interlock switches are Type 2 low level coded interlocking devices (ISO14119). According to ISO14119, the following is required to minimize defeat when installing and constructing systems:

1. Prevent dismantling or de-positioning of the elements of the interlocking device by use of non-detachable fixing (e.g. welding, gluing, one-way screws, riveting). However, use of non-detachable fixing can be an inappropriate solution in cases where a failure of the interlocking device during lifetime of the machinery can be expected and a fast change is necessary. In this case measures mentioned below, should be used to provide the required level of risk reduction.
2. Apply at least one out of the four measures below.
 - ① Mounting out of reach.
 - ② Physical obstruction or shielding.
 - ③ Mounting in hidden position.
 - ④ Integration of defeat monitoring by means of status monitoring/cyclic testing.

Instructions

- Regardless of door types, do not use the interlock switch as a door stop. Install a mechanical door stop at the end of the door to protect the interlock switch against excessive force.
- Do not apply excessive shock to the interlock switch when opening or closing the door. A shock to the interlock switch exceeding 1,000 m/s² may cause damage to the interlock switch.
- Do not open the lid of the interlock switch. Loosening the screws may cause damage to the interlock switch.
- Prevent foreign objects such as dust and liquids from entering the interlock switch while connecting a conduit or wiring.
- Plug the unused actuator entry slot using the slot plug supplied with the interlock switch.
- Use proprietary actuators only. When other actuators are used, the interlock switch may be damaged.
- Safety function of the door interlock switch will be lost if a spare key is inserted into the interlock switch. Make sure that a spare key is not used on the interlock switch.
- Ensure that the actuator is firmly fastened to the door (by welding, rivet, or special screws) in the appropriate location, so that the actuator cannot be removed.
- Do not cut the actuator. Modification of the actuator may cause damage.
- Although the HS9Z-A51A/A52A actuators alleviate shock when the actuator enters a slot in the interlock switch, make sure that excessive shock is not applied. If the rubber bushings become deformed or cracked, replace with new ones.

Mounting Examples

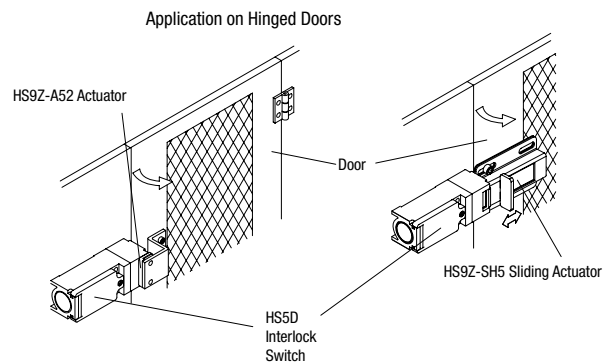
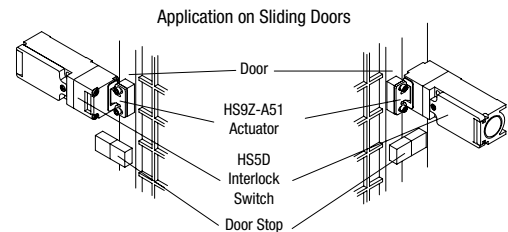

Installing the Head

Do not use the metal head of the HS5E-K/5L interlock switch on the HS5D.

When using these HS5D and HS5E-K/5L interlock switches adjacently, ensure that the heads are not interchanged.

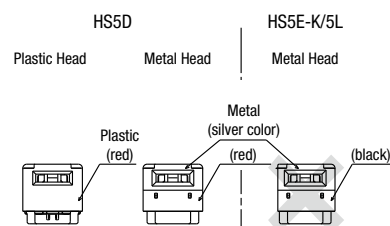

APEM

Switches & Pilot Lights

Control Boxes

Emergency Stop Switches

Enabling Switches

Safety Products

Explosion Proof

Terminal Blocks

Relays & Sockets

Circuit Protectors

Power Supplies

LED Illumination

Controllers

Operator Interfaces

Sensors

AUTO-ID

Interlock Switches

Non-contact Interlock Switches

Safety Laser Scanners

Safety Light Curtains

Safety Modules

HS6B

HS6E

HS5D

HS5L

HS1L

Actuators for HS1/HS5/HS6

Actuators/ Padlock Hasp

APEM

Switches & Pilot Lights

Control Boxes

Emergency Stop Switches

Enabling Switches

Safety Products

Explosion Proof

Terminal Blocks

Relays & Sockets

Circuit Protectors

Power Supplies

LED Illumination

Controllers

Operator Interfaces

Sensors

AUTO-ID

Interlock Switches

Non-contact Interlock Switches

Safety Laser Scanners

Safety Light Curtains

Safety Modules

HS6B

HS6E

HS5D

HS5L

HS1L

Actuators for HS1/HS5/HS6

Actuators/ Padlock Hasp

Instructions

Minimum Radius of Hinged Door

- When using the interlock switch for a hinged door, refer to the minimum radius of doors shown below. For the doors with small minimum radius, use angle adjustable actuators (HS9Z-A55).

Note: Because deviation or dislocation of hinged door may occur in actual applications, make sure of the correct operation before installation.

When using the HS9Z-A52 Actuator

- When the door hinge is on the extension line of the interlock switch surface:

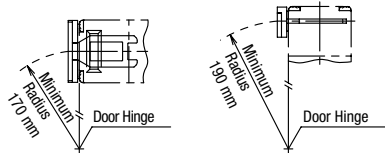

- When the door hinge is on the extension line of the actuator mounting surface:

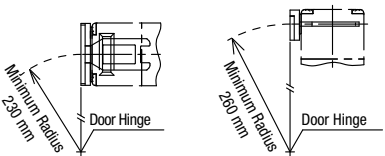

When using the HS9Z-A55 Angle Adjustable Actuator

- When the door hinge is on the extension line of the interlock switch surface:

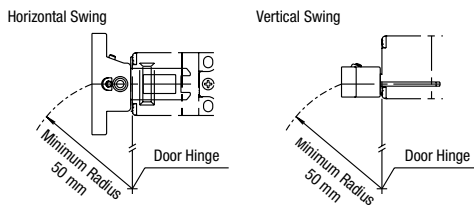

- When the door hinge is on the extension line of the actuator mounting surface:

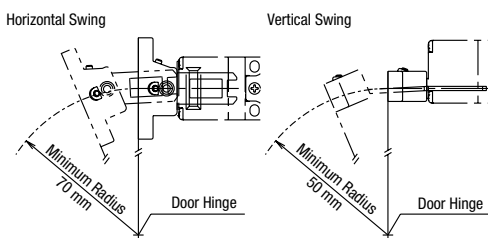

Actuator Angle Adjustment for the HS9Z-A55

- Using the angle adjustment screw, the actuator angle can be adjusted (see figures on E-065). Adjustable angle: 0 to 20°
- The larger the adjusted angle of the actuator, the smaller the applicable radius of the door opening. After installing the actuator, open the door. Then adjust the actuator so that its edge can be inserted properly into the actuator entry slot of the interlock switch.
- After adjusting the actuator angle, apply Loctite to the adjustment screw so that the screw will not loosen.

Rotating the Head

- The head of the HS5D can be rotated by removing the four screws from the corners of the HS5D head and reinstalling the head in the desired orientation. When reinstalling the head, make sure that no foreign object enters the interlock switch. Tighten the screws tightly, because loose tightening may cause malfunction.
- Recommended screw tightening torque: 0.9 to 1.1 N·m

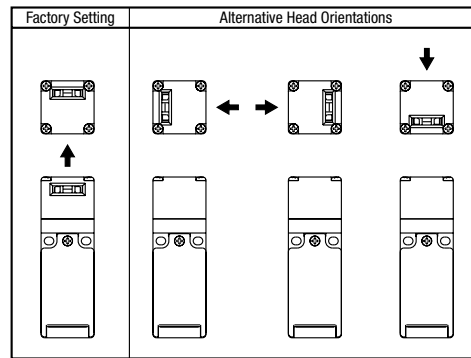

Head Removal Detection Function

Only the NC contact of the main circuit (11-12) turns OFF (open) when the head is removed, such as when rotating the head. Because NC contacts of other than the main circuit (11-12) turn ON (closed), be sure to connect the main circuit (11-12) to the safety circuit.

Recommended Tightening Torque

- Interlock Switch Mounting Screw: 1.8 ± 2.2 N·m (two M4 screws)
- Housing Lid Screw: 0.2 to 0.4 N·m (M3 screw)
- Terminal Screw: 0.6 to 0.8 N·m (M3 screw)
- Connector: 2.7 to 3.3 N·m
- Actuators
 - HS9Z-A51: 1.8 ± 2.2 N·m (two M4 screws)
 - HS9Z-A52: 0.8 ± 1.2 N·m (two M4 Phillips screws)
 - HS9Z-A51A/A52A: 1.0 to 1.5 N·m (two M4 screws)
 - HS9Z-A55: 1.0 to 1.5 N·m (two M4 screws)
- The above recommended tightening torques of the mounting screws are the values confirmed with hex socket head bolts. When other screws are used and tightened to a smaller torque, make sure that the screws do not come loose after mounting.
- Mounting bolts must be provided by the user.
- To avoid unauthorized or unintended removal of the interlock switch and the actuator, it is recommended that the interlock switch and the actuator be installed in an unremovable manner, for example using special screws or welding the screws.

Instructions

Applicable Crimping Terminal

When using crimping terminals, be sure to install insulation tubes on the crimping terminals to prevent electric shocks.

When using stranded wires, make sure that loose wires do not cause short circuit. Also do not solder the terminal to prevent loose wires.

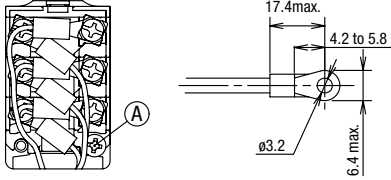

Recommended manufacturer: JST

Part No.: NO.5-3

Applicable wire size (with insulation tube): 0.2 to 0.5 mm²

Note: Do not remove screw A during wiring. Removing the screw may cause malfunction or damage.

Applicable Wire Size

0.5 to 1.5 mm²

Applicable Cable Glands

Use a cable gland with a degree of protection IP67.

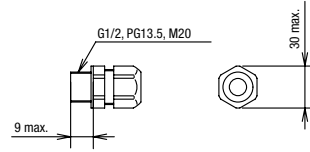

Refer to the instruction sheet from the URL below for recommended cable glands.

https://apac.idec.com/idec-apac/en/SGD/c/HS5D_Series

APEM

Switches & Pilot Lights

Control Boxes

Emergency Stop Switches

Enabling Switches

Safety Products

Explosion Proof

Terminal Blocks

Relays & Sockets

Circuit Protectors

Power Supplies

LED Illumination

Controllers

Operator Interfaces

Sensors

AUTO-ID

Interlock Switches

Non-contact Interlock Switches

Safety Laser Scanners

Safety Light Curtains

Safety Modules

HS6B

HS6E

HS5D

HS5L

HS1L

Actuators for HS1/HS5/HS6

Actuators/ Padlock Hasp

Ordering Terms and Conditions

Thank you for using IDEC Products.

By purchasing products listed in our catalogs, datasheets, and the like (hereinafter referred to as "Catalogs") you agree to be bound by these terms and conditions. Please read and agree to the terms and conditions before placing your order.

1. Notes on contents of Catalogs

- (1) Rated values, performance values, and specification values of IDEC products listed in this Catalog are values acquired under respective conditions in independent testing, and do not guarantee values gained in combined conditions.
Also, durability varies depending on the usage environment and usage conditions.
- (2) Reference data and reference values listed in Catalogs are for reference purposes only, and do not guarantee that the product will always operate appropriately in that range.
- (3) The specifications / appearance and accessories of IDEC products listed in Catalogs are subject to change or termination of sales without notice, for improvement or other reasons.
- (4) The content of Catalogs is subject to change without notice.

2. Note on applications

- (1) If using IDEC products in combination with other products, confirm the applicable laws / regulations and standards.
Also, confirm that IDEC products are compatible with your systems, machines, devices, and the like by using under the actual conditions. IDEC shall bear no liability whatsoever regarding the compatibility with IDEC products.
- (2) The usage examples and application examples listed in Catalogs are for reference purposes only. Therefore, when introducing a product, confirm the performance and safety of the instruments, devices, and the like before use. Furthermore, regarding these examples, IDEC does not grant license to use IDEC products to you, and IDEC offers no warranties regarding the ownership of intellectual property rights or non-infringement upon the intellectual property rights of third parties.
- (3) When using IDEC products, be cautious when implementing the following.
 - i. Use of IDEC products with sufficient allowance for rating and performance
 - ii. Safety design, including redundant design and malfunction prevention design that prevents other danger and damage even in the event that an IDEC product fails
 - iii. Wiring and installation that ensures the IDEC product used in your system, machine, device, or the like can perform and function according to its specifications
- (4) Continuing to use an IDEC product even after the performance has deteriorated can result in abnormal heat, smoke, fires, and the like due to insulation deterioration or the like. Perform periodic maintenance for IDEC products and the systems, machines, devices, and the like in which they are used.
- (5) IDEC products are developed and manufactured as general-purpose products for general industrial products. They are not intended for use in the following applications, and in the event that you use an IDEC product for these applications, unless otherwise agreed upon between you and IDEC, IDEC shall provide no guarantees whatsoever regarding IDEC products.
 - i. Use in applications that require a high degree of safety, including nuclear power control equipment, transportation equipment (railroads / airplanes / ships / vehicles / vehicle instruments, etc.), equipment for use in outer space, elevating equipment, medical instruments, safety devices, or any other equipment, instruments, or the like that could endanger life or human health
 - ii. Use in applications that require a high degree of reliability, such as provision systems for gas / waterworks / electricity, etc., systems that operate continuously for 24 hours, and settlement systems
 - iii. Use in applications where the product may be handled or used deviating from the specifications or conditions / environment listed in the Catalogs, such as equipment used outdoors or applications in environments subject to chemical pollution or electromagnetic interference
If you would like to use IDEC products in the above applications, be sure to consult with an IDEC sales representative.

3. Inspections

We ask that you implement inspections for IDEC products you purchase without delay, as well as thoroughly keep in mind management/maintenance regarding handling of the product before and during the inspection.

4. Warranty

- (1) Warranty period
The warranty period for IDEC products shall be one (1) year after purchase or delivery to the specified location. However, this shall not apply in cases where there is a different specification in the Catalogs or there is another agreement in place between you and IDEC.
- (2) Warranty scope
Should a failure occur in an IDEC product during the above warranty period for reasons attributable to IDEC, then IDEC shall replace or repair that product, free of charge, at the purchase location / delivery location of the product, or an IDEC service base. However, failures caused by the following reasons shall be deemed outside the scope of this warranty.
 - i. The product was handled or used deviating from the conditions / environment listed in the Catalogs
 - ii. The failure was caused by reasons other than an IDEC product
 - iii. Modification or repair was performed by a party other than IDEC
 - iv. The failure was caused by a software program of a party other than IDEC
 - v. The product was used outside of its original purpose
 - vi. Replacement of maintenance parts, installation of accessories, or the like was not performed properly in accordance with the user's manual and Catalogs
 - vii. The failure could not have been predicted with the scientific and technical standards at the time when the product was shipped from IDEC
 - viii. The failure was due to other causes not attributable to IDEC (including cases of force majeure such as natural disasters and other disasters)Furthermore, the warranty described here refers to a warranty on the IDEC product as a unit, and damages induced by the failure of an IDEC product are excluded from this warranty.

5. Limitation of liability

The warranty listed in this Agreement is the full and complete warranty for IDEC products, and IDEC shall bear no liability whatsoever regarding special damages, indirect damages, incidental damages, or passive damages that occurred due to an IDEC product.

6. Service scope

The prices of IDEC products do not include the cost of services, such as dispatching technicians. Therefore, separate fees are required in the following cases.

- (1) Instructions for installation / adjustment and accompaniment at test operation (including creating application software and testing operation, etc.)
- (2) Maintenance inspections, adjustments, and repairs
- (3) Technical instructions and technical training
- (4) Product tests or inspections specified by you

The above content assumes transactions and usage within your region. Please consult with an IDEC sales representative regarding transactions and usage outside of your region. Also, IDEC provides no guarantees whatsoever regarding IDEC products sold outside your region.

IDEC CORPORATION

Head Office 6-64, Nishi-Miyahara-2-Chome, Yodogawa-ku, Osaka 532-0004, Japan

USA IDEC Corporation
EMEA APEM SAS

Singapore IDEC Izumi Asia Pte. Ltd.
Thailand IDEC Asia (Thailand) Co., Ltd.
India IDEC Controls India Private Ltd.

China IDEC (Shanghai) Corporation
IDEC Izumi (H.K.) Co., Ltd.
Taiwan IDEC Taiwan Corporation

 www.idec.com

Japan IDEC Corporation

Specifications and other descriptions in this brochure are subject to change without notice.

2023 IDEC Corporation, All Rights Reserved.

